

REZNOR®

UK
CATALOGUE
2026

**OVER
130 YEARS
OF
INNOVATION**

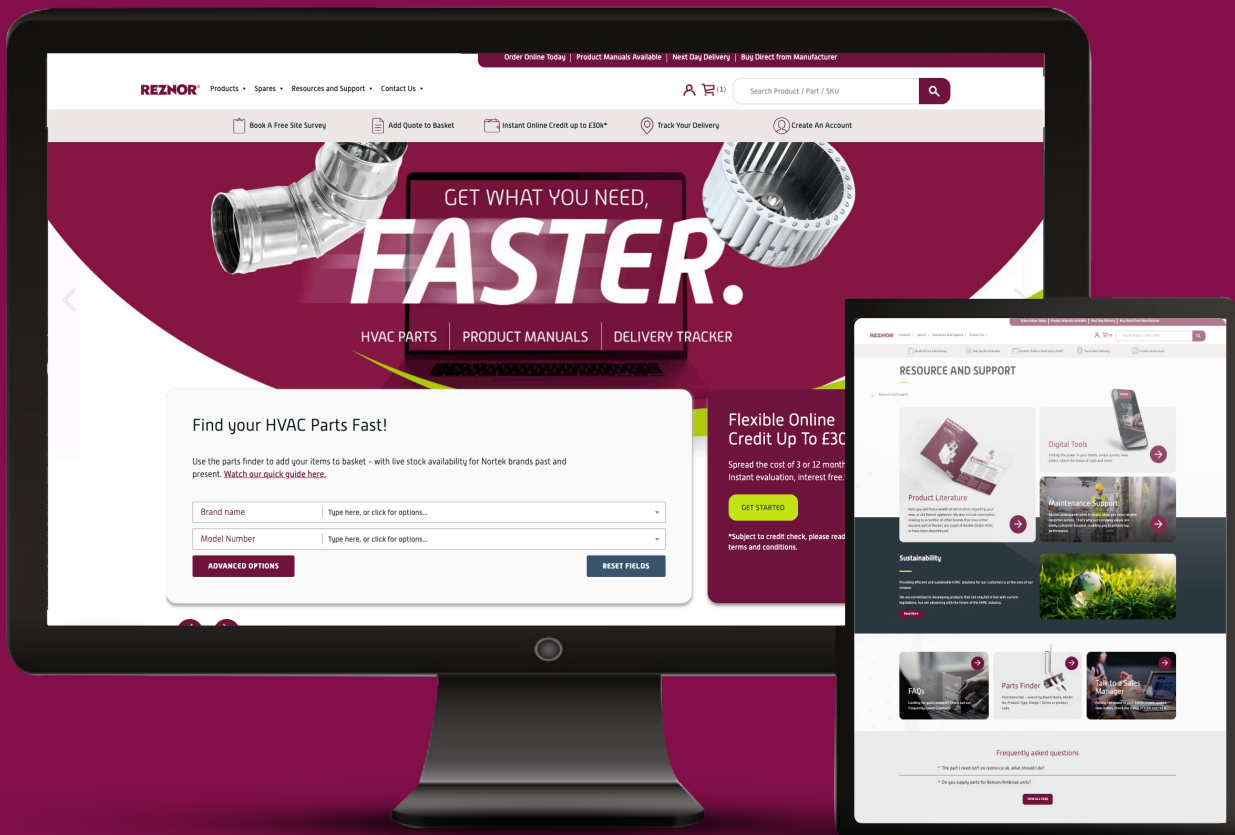



VIEW & ORDER ONLINE FAST

Take advantage of our user-friendly online spares and heater platform. You can order full heating systems, ancillaries including flue and spare parts for all Nortek branded products, past and present, including Reznor, AmbiRad, NordairNiche, Benson and AirBloc.

[VISIT REZNOR.CO.UK TO ORDER](https://www.reznor.co.uk)

Not sure where to start?

Request a free design for a new project and add your quotes to basket online.

ONLINE RESOURCES & TECHNICAL LIBRARY

Did you know Reznor offers a wide range of online resources to support you? Visit [reznor.co.uk](https://www.reznor.co.uk) to find the latest updates and product news, as well as access technical literature and spare parts information for Reznor, AmbiRad, NordairNiche, Benson and AirBloc units.

RADIANT TUBE HEATERS

VSUTE - U TUBE MODELS	05
VSLIE - LINEAR MODELS	06
VSDLE - DOUBLE LINEAR MODELS	07
ACCESSORIES - VISION MODELS	08
SCR-ECO - GAS FIRED RADIANT PLAQUE	11
SORRENTO - ELECTRIC RADIANT HEATERS	12
QUARTZ GLOW - ELECTRIC RADIANT HEATERS	13
SONNING² OHA - SINGLE BURNER CONTINUOUS RADIANT TUBE SYSTEM	14
NOR-RAY-VAC - GAS FIRED CONTINUOUS RADIANT TUBE SYSTEM	15

WARM AIR HEATERS, VENTILATION, HEAT MODULES & PUMPS

RHECO - GAS FIRED CONDENSING SUSPENDED UNIT HEATERS	16
PHOTON - GAS FIRED UNIT HEATER	17
STAINLESS STEEL FLUE - FOR GAS FIRED UNIT HEATERS	18
E+ ELECTRIC WARM AIR HEATER	19
DS - DESTRATIFICATION FANS	20
COMET+ - CABINET HEATERS	21
NOVA EMS - ENERGY MANAGEMENT SYSTEM	24
SONNIGER - HEATER CONDENS	26
LIRA - HEAT PUMP	28
NORDAIR NICHE - HEATING & VENTILATION SYSTEMS	29
EURO T+ - HEATING & VENTILATION SYSTEMS	30
RHC+ - HEAT MODULE	31

AIR CURTAINS

GUARDIAN EC - SURFACE MOUNTED SERIES	32
GUARDIAN EC - RECESSED MOUNTED SERIES	33
ACCESSORIES - FOR GUARDIAN EC SERIES	34
AC/ACR MINI SERIES - MINI SURFACE MOUNTED & RECESSED SERIES	35
ACT - ELECTRIC CEILING TILE HEATERS	36
AB - INDUSTRIAL SERIES	37
ACCESSORIES - FOR AB INDUSTRIAL SERIES	39

MISCELLANEOUS

CARRIAGE CHARGES	40
TERMS & CONDITIONS	42
WARRANTY	43

OUR HISTORY

1888

REZNOR®

Reznor was founded in Mercer, Pennsylvania by George Reznor

1935

Reznor developed the first gas unit heater for industrial applications

1979

AMBIRAD

AmbiRad was founded, supplying gas fired radiant products

1993

Launch of the Nor-Ray-Vac (NRV) system

2006

NORDAIRNICHE

Acquisition of Sonning Heating systems and merger of Nordair/Niche

2009

BENSON

Acquisition of Benson Heating Ltd

2012

Thomas & Betts acquired by ABB Group

2014

REZNOR®
AMBIRAD
BENSON
AIRBLOC
NORDAIRNICHE
MOLIMEX-THERM

Nortek acquires Thomas & Betts' HVAC business including Reznor, AmbiRad, Gaz Industries & Molimex Therm

2018

Product brands AmbiRad, Benson & Airbloc merged into Reznor

Future

The future is this way...

RADIANT TUBE HEATERS

RADIANT TUBE HEATER

VSUTE

VS models are supplied complete with turbulators, aluminised steel reflector and endcaps.

VISION VSUTE U-TUBE MODELS (INDUCED BURNER)
PROPANE MODELS AVAILABLE



MODEL	DESCRIPTION	HEAT INPUT kW	GAS RATE (m ³ /h)	NAT GAS	LPG	LENGTH (m)
VS15UTEN	U-TUBE	15.0	1.4	1	1	4.5
VS20UTEN	U-TUBE	19.5	1.9	1	1	5.1
VS25UTEN	U-TUBE	23.5	2.3	1	1	5.1
VS30UTEN	U-TUBE	32.0	3.1	1	1	7.6
VS35UTEN	U-TUBE	36.0	3.4	1	1	7.6
VS40UTEN	U-TUBE	40.0	3.8	4	4	8.5
VS45UTEN	U-TUBE	44.0	4.2	4	4	9.4
VS50UTEN	U-TUBE	48.0	4.6	4	4	9.4

VISION MODELS CAN BE USED IN A HERRINGBONE SYSTEM INCORPORATING UP TO 10 HEATERS
PLEASE CALL **01384 489700** FOR DETAILS

RADIANT TUBE HEATER

VSLIE STANDARD

VSLIE models are supplied complete with turbulators, aluminised reflector and end caps.

Vision VSLIE linear models [induced burner] - Standard length models - PROPANE MODELS AVAILABLE

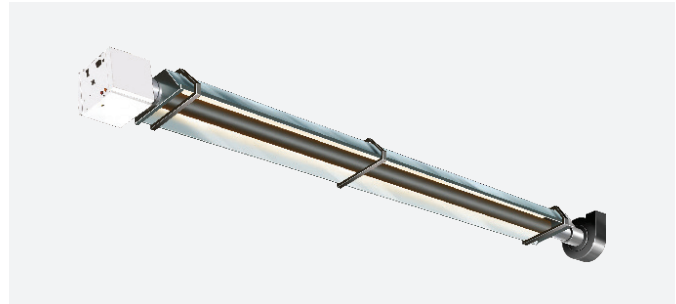

MODEL	DESCRIPTION	HEAT INPUT kW	GAS RATE (m ³ /h)	FLUE ADAPTER REFERENCE		LENGTH (m)
				NAT GAS	LPG	
VS15LIEN8	STANDARD 'SL' TUBE	15.0	1.4	1	1	8.0
VS20LIEN10-5	STANDARD 'SL' TUBE	19.5	1.9	1	1	10.5
VS25LIEN8	STANDARD 'SL' TUBE	23.5	2.3	1	1	8.0
VS30LIEN10-5	STANDARD 'SL' TUBE	32.0	3.1	1	4	10.5
VS35LIEN10-5	STANDARD 'SL' TUBE	36.0	3.4	1	4	10.5
VS40LIEN13-5	STANDARD 'SL' TUBE	40.0	3.8	1	4	13.5
VS45LIEN13-5	STANDARD 'SL' TUBE	44.0	4.2	1	4	13.5
VS50LIEN13-5	STANDARD 'SL' TUBE	48.0	4.6	4	4	13.5

RADIANT TUBE HEATER

VSLIE EXTENDED

VSLIE models are supplied complete with turbulators, aluminised reflector and end caps.

Vision VSLIE linear models [induced burner] - EXTENDED length models - PROPANE MODELS AVAILABLE

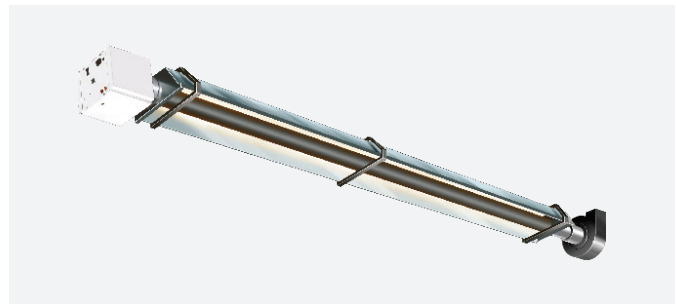

MODEL	DESCRIPTION	HEAT INPUT kW	GAS RATE (m ³ /h)	FLUE ADAPTER REFERENCE		LENGTH (m)
				NAT GAS	LPG	
VS25LIEN10-5	EXTENDED 'SL' TUBE	23.5	2.3	1	1	10.5
VS30LIEN13-5	EXTENDED 'SL' TUBE	29.5	2.8	1	1	13.5
VS35LIEN13-5	EXTENDED 'SL' TUBE	36.0	3.4	1	1	13.5
VS40LIEN16	EXTENDED 'SL' TUBE	40.0	3.8	1	4	16.0
VS45LIEN16	EXTENDED 'SL' TUBE	44.0	4.2	1	4	16.0
VS50LIEN16	EXTENDED 'SL' TUBE	50.0	4.8	1	4	16.0

VISION MODELS CAN BE USED IN A HERRINGBONE SYSTEM INCORPORATING UP TO 10 HEATERS
PLEASE CALL **01384 489700** FOR DETAILS

RADIANT TUBE HEATERS

RADIANT TUBE HEATER

VSDLE STANDARD

VS models are supplied complete with turbulators, aluminised steel reflector and endcaps.

Vision VSDLE double linear models (induced burner) -
Standard length models |
PROPANE MODELS AVAILABLE

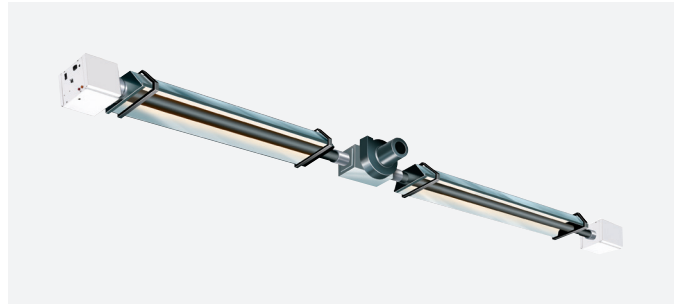

MODEL	DESCRIPTION	HEAT INPUT KW	GAS RATE (m ³ /h)	FLUE ADAPTER REFERENCE		LENGTH (m)
				NAT GAS	LPG	
VS15DLEN16	Standard 'DL' Tube	30.0	2.8	4	4	16.0
VS20DLEN21	Standard 'DL' Tube	39.0	3.8	4	4	
VS25DLEN16	Standard 'DL' Tube	47.0	4.6	4	4	16.0
VS30DLEN21	Standard 'DL' Tube	64.0	6.1	4	4	21.0
VS35DLEN21	Standard 'DL' Tube	72.0	6.8	4	4	21.0
VS40DLEN27	Standard 'DL' Tube	80.0	7.6	4	5	27.0
VS45DLEN27	Standard 'DL' Tube	88.0	8.4	5	5	27.0
VS50DLEN27	Standard 'DL' Tube	96.0	9.2	5	5	27.0

RADIANT TUBE HEATER

VSDLE EXTENDED

VS models are supplied complete with turbulators, aluminised steel reflector and endcaps.

Vision VSLIE double linear models (induced burner) -
Extended length models |
PROPANE MODELS AVAILABLE

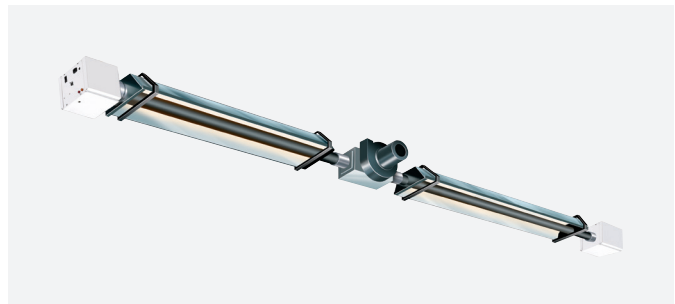

MODEL	DESCRIPTION	HEAT INPUT KW	GAS RATE (m ³ /h)	FLUE ADAPTER REFERENCE		LENGTH (m)
				NAT GAS	LPG	
VS25DLEN21	Extended 'DL' Tube	47.0	4.6	4	4	21.0
VS30DLEN27	Extended 'DL' Tube	64.0	6.1	4	4	27.0
VS35DLEN27	Extended 'DL' Tube	72.0	6.8	4	4	27.0
VS40DLEN32	Extended 'DL' Tube	80.0	7.6	4	4	32.0
VS50DLEN32	Extended 'DL' Tube	96.0	9.6	5	5	32.0

VISION MODELS CAN BE USED IN A HERRINGBONE SYSTEM INCORPORATING UP TO 10 HEATERS
PLEASE CALL **01384 489700** FOR DETAILS

RADIANT TUBE HEATER ACCESSORIES

PART NUMBER	DESCRIPTION
6506	1/2" Gas Valve
6500	1/2" Flexible gas connection (600mm long) Plastic coated stainless steel with union to BS6501 part1. 1991 Class "C" construction
6500-2	1/2" Flexible gas connection (1.0m long for use with VS40LIE and above) Plastic coated stainless steel with union to BS6501 part1. 1991 Class "C" construction
6515	Suspension chain (galvanised, 10m length)
6516	Suspension chain (galvanised, 90m length)
6524-SUB	Speedlinks x 8
6518	D Shackle (galvanised) each
C766300-SUB	Tumbuckle assembly
V-LO	Lockout relay
6124	Run on timer (0 to 2hrs)
1350-3	Undershield deflector 2438mm long c/w 2 x 3" munson rings. For models VS15 to 30
1350-4	Undershield deflector 2438mm long c/w 2 x 4" munson rings. For models VS35 to 50

RADIANT TUBE HEATER ACCESSORIES

PROTECTIVE WIRE GUARD

PART NUMBER	DESCRIPTION	MODEL/DESCRIPTION
BG15UTE	U-TUBE	VS15UTEN
BG20-25UTE	U-TUBE	VS20UTEN & VS25UTEN
BG30-35UTE	U-TUBE	VS30UTEN & 35UTEN
BG40UTE	U-TUBE	VS40UTEN
BG45-50UTE	U-TUBE	VS45UTEN & 50UTEN
BG3LE8	U-TUBE	VS15LEN 8m
BG3LE10-5	U-TUBE	VS20LEN & 25LEN 10.5m
BG4LE10-5	U-TUBE	VS30LEN & 35LEN 10.5m
BG4LE13-5	U-TUBE	VS35LEN, 40LEN, 45LEN & 50LEN 13.5m
BG4LE16	U-TUBE	VS40LEN, 45LEN & 50LEN 16m
6569	U-TUBE	Black bulb sensor guard

RADIANT TUBE HEATER ACCESSORIES

RADIANT TUBE HEATER ACCESSORIES

WALL MOUNTING BRACKETS

PART NUMBER	DESCRIPTION	BRACKETS REQUIRED PER HEATER
1001836	VS 30, 35 & 40 U-TUBES	4
1001836	VS 45 & 50 U-TUBES	5
1001836	VS15 8m model & VS25 8m Linear	4
1001836	VS20, 25, 30 & 35 10.5m Linear	5
1001836	VS30, 35, 40, 45 & 50 13.5m Linear	6
1001836	VS40, 45 & 50 16m Linear	7

RADIANT TUBE HEATER ACCESSORIES

FRESH AIR INTAKE KIT & ADAPTORS (100MM DIAMETER, SINGLE SKIN ALUMINIUM)

PART NUMBER	DESCRIPTION
VSI-DA	VS & VSLI Ducted Air Adaptor
FAFK-4	Fresh air intake kit (3m x 100mm ID aluminium lengths of pipe (7070-SUB), 1 x rubberised flashing plate & fixing kit (33-51-022) & 1 x 100mm dia terminal (L101590-SUB))

RADIANT TUBE HEATER ACCESSORIES

FLUE CONNECTORS

PART NUMBER	DESCRIPTION	ADAPTER REF
7177-SUB	125mm (5'') Fan/flue connector	1
7176-SUB	125mm (5'') Fan/flue connector	4
202365	125mm (5'') Fan/flue connector	5

RADIANT TUBE HEATER ACCESSORIES

**TWIN WALL FLUE COMPONENTS
(125MM DIAMETER, 140MM OUTSIDE DIAMETER)**

PART NUMBER	DESCRIPTION
7156-FLUE33	914mm Length of pipe
7157-FLUE32	1524mm Length of pipe
7158-FLUE31	450mm Adjustable length of pipe
33-51-222	Rubberised roof plate with fixing kit
7162-FLUE34	Gas vent Terminal/cowl
7166-FLUE30	Adjustable elbow 0 to 90°

RADIANT TUBE HEATER ACCESSORIES

TWIN WALL FLUE KITS

PART NUMBER	DESCRIPTION
TWFK-5A-1	Kit 'A' 1 x 1524mm length tube (7157-FLUE32), 1 x 914mm length tube (7156-FLUE33), 1 x 450mm adjustable length flue (7158-FLUE31), rubberised roof plate and fixing kit (33-51-222) and terminal (7162-FLUE34)
TWFK-5B-1	Kit 'B' as Kit 'A' plus 2 adjustable elbows (7166-FLUE30)

RADIANT TUBE HEATER ACCESSORIES

SMARTCOM CONTROLS

PART NUMBER	MODEL
B-SC3ML-SZR	SmartCom single zone controller Std functions include (but not limited to):- single stage heating, self-adapting optimised start, volt free BMS over-ride, timeclock with overtime facility, fan only operation, frost protection, night set- back, burner lockout indication with reset, internal thermostat
B-SC3ML-MZR	SmartCom multi zone controller As single zone model, but with the following additional functions: two stage heating & cooling, modulating burner control, networking function
29-01-222	SmartCom black bulb sensor

RADIANT PLAQUE HEATER

RADIANT PLAQUE HEATER

SCR-ECO

SCR-ECO units are for use with natural gas as standard and are fitted with a fully automatic burner ignition system requiring a 240v single phase electrical supply. Each unit is supplied with wall mounting brackets and a loose LPG jet.



MODEL	DESCRIPTION	HEAT INPUT KW
SCR-ECO-7/4	7.5kW gas fired plaque heater	7.5
SCR-ECO-18/10	17.5kW gas fired plaque heater	17.5
SCR-ECO-29/16	27.0kW gas fired plaque heater	27.0
SCR-ECO-44/12+12	41.8kW gas fired plaque heater	41.0

RADIANT PLAQUE HEATER

SUNDRIES

PART NUMBER	DESCRIPTION
6506	1/2" BSP Gas tap
6500	1/2" BSP Flexible connector 600mm long

RADIANT PLAQUE HEATER
SORRENTO

The Sorrento range is a robust weatherproof heater available in three configurations.

All models are supplied with a wall mounting bracket & for use with single phase electrical supply.

Sorrento Electric Heater | BRACKETS INCLUDED
 STOCKED IN BLACK, SILVER & WHITE.
 Subject to availability



MODEL	DESCRIPTION	HEAT INPUT KW	DIMENSIONS (mm)	MOUNTING HEIGHT (mm)
SOR15-BLACK	Single linear tube	1.5	402 x 227 x 112	2
SOR15-SILVER	Single linear tube	1.5	402 x 227 x 112	2
SORDL30-BLACK	Double linear tube	3	790 x 227 x 112	2.5 to 4.0
SORDL30-WHITE	Double linear tube	3	790 x 227 x 112	2.5 to 4.0
SORDL30-SILVER	Double linear tube	3	790 x 227 x 112	2.5 to 4.0
SORTL45-BLACK	Double linear tube	4.5	1178 x 227 x 112	2.5 to 4.0
SORTL45-WHITE	Double linear tube	4.5	1178 x 227 x 112	2.5 to 4.0

ELECTRIC RADIANT HEATER

QUARTZ GLOW

The Apollo range of indoor heaters, manufactured from extruded aluminium, offers a choice of power options 1.5kW - 9kW to suit all situations and requirements. They are adjustable both vertically and horizontally for accurate heat placement. Safety guards are available where required.

APOLLO Electric Heater | BRACKETS INCLUDED
AVAILABLE IN BLACK, SILVER & WHITE. Subject to availability



MODEL	DESCRIPTION	HEAT INPUT KW	DIMENSIONS (mm)	MOUNTING HEIGHT (mm)
QH15-1	Single tube	1.5	422 x 255 x 110	2.0 to 4.0
QH 30-1	Double tube	3.0	422 x 390 x 110	3.0 to 4.5
QH 45-1	Triple tube	4.5	422 x 525 x 110	3.5 to 5.5
QHL 30-1	Double linear tube	3.0	857 x 255 x 110	3.0 to 4.5
QHL 45-1	Triple linear tube	4.5	1282 x 255 x 110	3.5 to 5.5
QHL 45-3	Triple linear tube - 3ph	4.5	1282 x 255 x 110	3.5 to 5.5
QHL 90-3	Triple double linear tube - 3ph	9.0	857 x 630 x 110	5.0 to 7.0

CONTINUOUS RADIANT TUBE HEATER SONNING² OHA

Sonning2 OHA is a continuous gas fired radiant tube heating system fitted with either a single internal or external burner, which employs 80% flue gas re-circulation and is designed specially for the building it is required to heat.

The inclusion of modulating burner on the OHA RHE ranges enables thermal efficiencies of up to 96% to be achieved.

The OHA system is designed to provide uniform heat coverage over the entire floor area. The system can also cater for distinct zones providing a varied degree of comfort level within the overall layout of the building.

Nortek strives to become part of the 'design team', working closely with engineers or end users to determine the specific design parameters for the OHA scheme layout. This contact between the company's engineers and the system designer or client will give the most effective OHA system.

MODEL RANGE

The OHA Series radiant tube heating system includes nine natural gas or propane burner models from 50 to 400kW, radiant tube lengths from 25 to 400 metres. Maximum tube temperatures range from 200°C to 350°C.

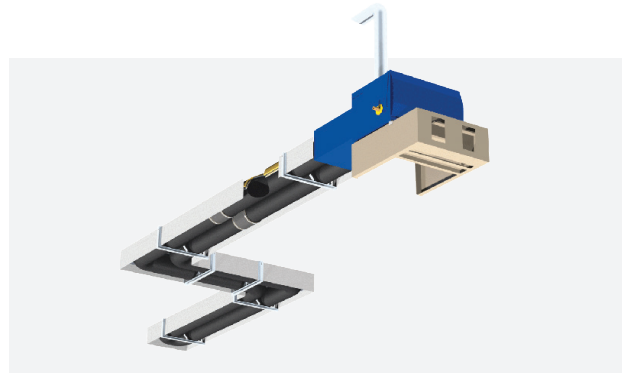

The OHA RHE Modulating Series radiant tube heating system includes 6 natural gas or propane burner models from 100 to 370kW, radiant tube lengths from 35 to 250 metres. Maximum tube temperatures range from 120°C to 290°C.

The heaters will operate equally as effective on a wide variety of fuels; natural gas, LPG and oil (OHA only).

Please contact sales on 01384 489700 for more information on Sonning2 continuous radiant tube system.

LIST PRICE

££POA



CONTINUOUS RADIANT TUBE HEATER NOR-RAY-VAC

Introducing the revitalized Nor-Ray-Vac, your trusted radiant system, back by popular demand with cutting edge technology and market leading excellence poised to meet the evolving needs of our customers.

The Nor-Ray-Vac is a gas fired continuous radiant tube heating system, uniquely designed and specified for the building it is required to heat.

The following criteria form the basis of each particular system design:

- Heat loss of the building for the required thermal environment
- Local climate conditions
- Type of activity in the building
- Specific architectural features relating to the structure

The Nor-Ray-Vac is a conventional radiant heating system, that operates with on/off control and continuous modulation. This is achieved by adjusting the vacuum as the building temperature varies. The optimum air/ gas ratio is maintained giving maximum comfort & efficiency whilst minimising fuel consumption.

FEATURES INCLUDE:

- Reduces overall costs, with savings of up to 60% being achieved over conventional heating systems
- Stoichiometric or 'perfect' combustion
- Can be designed to a 92% combustion efficiency & >92% thermal efficiency
- Good aesthetic integration with building

MODEL RANGE

The Nor-Ray-Vac Series continuous radiant tube heating system is available in natural gas or propane versions. There are four models in the range - 24kW, 32kW, 38kW and 46kW output - with maximum radiant tube lengths from 9.4 to 27 meters.

Modulating burners are provided on all models allowing them to modulate from 50% to 100% duty [24/12kW, 32/16kW, 38/19kW and 46/23kW]. Maximum tube temperatures range from 450°C to 480°C.

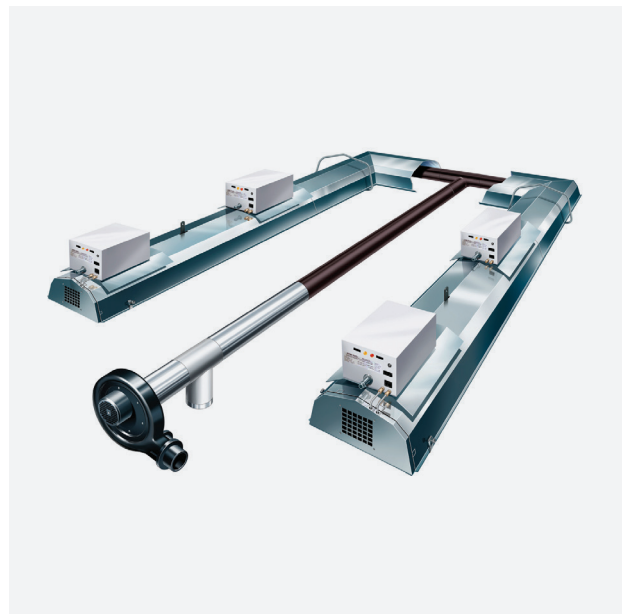

Please contact sales on 01384 489700 for more information on Nor-Ray-Vac continuous radiant tube system

LIST PRICE

£EPOA

CONDENSING GAS FIRED UNIT HEATER

RHECO

Gas fired ultra high efficiency, low NOx condensing, suspended warm air unit heater.

Supplied with axial fan, modulating burner, automatic ignition and horizontal louvers.

PROPANE MODELS AVAILABLE.
VERTICAL LOUVERS SOLD SEPARATELY



MODEL	HEAT INPUT KW	AIRFLOW (m3/h)	FLUE DIA (mm)
ULSA 025	25.0	2900	80
ULSA 035	33.0	3700	80
ULSA 050	50.0	5600	80
ULSA 075	70.0	7900	100
ULSA 100	94.0	10500	100

EC modulating versions are also available that are manufactured with a supply modulating air fan as standard. Contact us to find out more about our high efficiency range.

CONDENSING GAS FIRED UNIT HEATER

RHECO OPTIONAL EQUIPMENT

PART NUMBER	DESCRIPTION
B-SC3ML-MZR	SmartCom multi zone control panel
29-01-219	Remote room sensor (for use with SmartCom)

CONDENSING GAS FIRED UNIT HEATER

SUNDRIES

PART NUMBER	DESCRIPTION
6506	1/2" BSP gas valve
6510	3/4" BSP gas valve
6500	1/2" BSP flexible connection
6500-1	3/4" BSP flexible connection
TBA	Wall brackets
6529	Drop rods M10 x 3 metre
OP207-1-U 025/050/075/100	Vertical Louvers

GAS FIRED UNIT HEATER

GAS FIRED UNIT HEATER

PHOTON

Gas fired unit heater with a high airflow axial fan for free blowing applications, a modulating burner and units are available for natural gas (G20, G25, G25.3) as standard.



MODEL	HEAT OUTPUT KW	AIRFLOW (m3/h)	FLUE DIA (mm)
PHOTON10-2	9.34	1223	80
PHOTON20-2	18.39	2533	80
PHOTON25-2	26.54	3035	100
PHOTON35-2	31.68	4120	100
PHOTON45-2	42.24	4562	100
PHOTON55-2	53.46	5877	100
PHOTON65-2	63.59	7125	130
PHOTON70-2	71.25	8681	130
PHOTON100-2	97.87	10350	130

PART NUMBER	DESCRIPTION
103732 3/4/5/6/7/8/9	Air outlet discharge 30o downturn nozzle

PART NUMBER	DESCRIPTION
B-sc3ml-mzr	SmartCom multi zone control panel
29-01-219	Remote room sensor (for use with SmartCom)
6506	1/2" BSP gas valve
6510	3/4" BSP gas valve
1023509	1" BSP gas valve
6500	1/2" BSP flexible connection
6500-1	3/4" BSP flexible connection
1023510	1" BSP flexible connection
R-WMB1	Fixed Wall mounting Bracket Photon 10, 20
R-WMB2	Fixed Wall mounting Bracket Photon 25-100
6529	Drop rods M10 x 3 metre

OPTION 1 – NON-BALANCED FAN ASSISTED STAINLESS STEEL FLUE ONLY

DESCRIPTION		80 mm	100 mm	130 mm
Flue locking bands	Part no.	33-54-080	33-54-100	33-54-130
	List price	27.27	22.68	22.68

DESCRIPTION		80 mm	100 mm	130 mm
Horizontal flue terminal	Part No.	33-54-006-FLUE21	33-54-106-FLUE25	33-54-206-FLUE26
	List Price	180.85	195.24	226.86
Vertical flue terminal	Part No.	33-54-007-FLUE22	33-54-107-FLUE4	33-54-207-FLUE10
	List Price	56.15	83.52	86.24
To connect with terminal & heater				
Pipe 1m length	Part No.	33-54-001-FLUE16	33-54-101-FLUE1	33-54-201-FLUE5
	List Price	41.17	46.01	64.88
Pipe 0.5m length	Part No.	33-54-002-FLUE17	33-54-102-FLUE23	33-54-202-FLUE6
	List Price	30.68	37.04	44.48
Pipe 0.25m length	Part No.	33-54-003-FLUE18	33-54-103-FLUE24	33-54-203-FLUE7
	List Price	24.06	27.37	41.17
90° Elbow	Part No.	33-54-005-FLUE20	33-54-105-FLUE3	33-54-205-FLUE9
	List Price	37.57	44.12	52.98
45° Elbow	Part No.	33-54-004-FLUE19	33-54-104-FLUE2	33-54-204-FLUE8
	List Price	34.21	29.15	46.01
Horizontal flue terminal guard (basket)	Part No.	39-15-001	39-15-001	39-15-001
	List Price	52.78	52.78	52.78
Flexible flashing for flat roof or corrugated sheets (single pipe)	Part No.	33-51-022	33-51-522	33-51-622
	List Price	122.69	96.74	254.70

OPTION 2 – BALANCED ROOM SEALED STAINLESS STEEL FLUE COMPONENTS

DESCRIPTION		80 mm	100 mm	130 mm
Horizontal concentric flue terminal assembly	Part No.	33-55-009-FLUE27	33-55-106-FLUE13	33-55-206-FLUE12
	List Price	226.03	282.06	407.69
Vertical concentric flue terminal assembly	Part No.	33-55-010-FLUE28	33-55-107-FLUE11	33-55-207-FLUE29
	List Price	323.71	424.45	523.90
To connect with terminal & heater				
Pipe 1m length	Part No.	33-54-001-FLUE16	33-54-101-FLUE1	33-54-201-FLUE5
	List Price	41.17	46.01	64.88
Pipe 0.5m length	Part No.	33-54-002-FLUE17	33-54-102-FLUE23	33-54-202-FLUE6
	List Price	30.68	37.04	44.48
Pipe 0.25m length	Part No.	33-54-003-FLUE18	33-54-103-FLUE24	33-54-203-FLUE7
	List Price	24.06	27.37	41.17
90° Elbow	Part No.	33-54-005-FLUE20	33-54-105-FLUE3	33-54-205-FLUE9
	List Price	37.57	44.12	52.98
45° Elbow	Part No.	33-54-004-FLUE19	33-54-104-FLUE2	33-54-204-FLUE8
	List Price	34.21	29.15	46.01
Balanced Vertical Transition Kit	Part No.	VK-80	VK-100	VK-130
	List Price	168.20	174.51	256.94
Horizontal flue terminal guard (basket)	Part No.	39-15-001	39-15-001	39-15-001
	List Price	52.78	52.78	52.78
Flexible flashing for flat roof or corrugated sheets (single pipe)	Part No.	33-51-022	33-51-522	33-51-622
	List Price	122.69	96.74	254.70

ELECTRIC WARM AIR HEATER

ELECTRIC WARM AIR HEATER

E+

The e+ provides a unique, gas-free alternative for warm air heating. With an instant start up time and adaptive control for additional energy savings.



PART NUMBER	HEAT OUTPUT KW	PRIMARY AIRFLOW (m3/h) Speed F1	PRIMARY AIRFLOW (m3/h) Speed F2
EUH10	10	1275	1500
EUH20	20	2000	2250
EUH30	30	3000	3250

PART NUMBER	DESCRIPTION
EUH-CTRL-KIT-10M	e+ controller kit with 10m RJ45 cable
EUH-CTRL-KIT-30M	e+ controller kit with 30m RJ45 cable
EUH-CTRL-KIT-50M	e+ controller kit with 50m RJ45 cable

DESTRATIFICATION FANS

DS DESTRATIFICATION FANS

Destratification fans work by recirculating rising warm air back down to where it is needed.

Reznor fans create a strong downdraft to force trapped ceiling heat back to the floor, providing uniform heating and reducing roof temperature.

These fans effectively combat thermal stratification by ensuring heat is evenly distributed throughout the space.

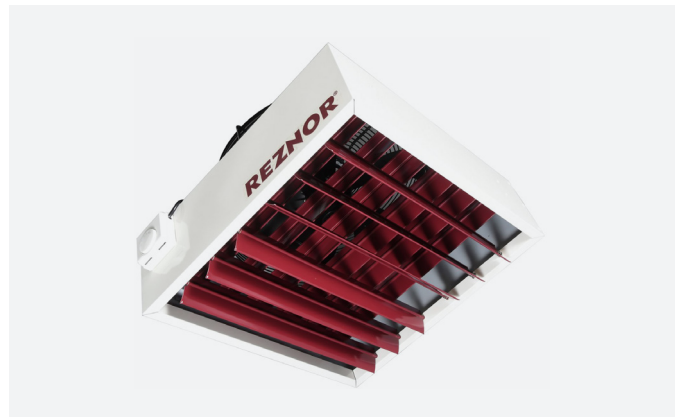

PART NUMBER	MODEL	PRIMARY AIRFLOW (m3/h)	MOUNTING HEIGHT
DS3-4	DS 3	3000	4 to 8m
DS4-4	DS 4	5300	6 to 12m
DS6-4	DS 6	6600	10 to 18m
DS10-4	DS 10	9000	10 to 18m

DESTRATIFICATION FANS

DS OPTIONAL EQUIPMENT

PART NUMBER	DESCRIPTION LIST PRICE
28-00-301	Stainless Steel wire roof fixing kit

COMET+ CABINET HEATERS

COMET+

The COMET+ range of cabinet heaters combines innovative design with proven heat exchanger technology to provide a efficient cost effective durable range. Standard efficiency models available with modulating burner with a 2:1 turn down with use with Natural Gas (G20) and Propane (G31).

These models are also available with the use of both 35 sec and Kerosine oil. High efficiency (condensing) models are only available in Natural Gas (G20), with modulating burner with 4:1 turn down. All models have EC plug fans as standard.

All models are available in Natural Gas fired, Propane fired or Oil fired versions. Oil fired models are supplied with a fire valve and an oil filter as loose components

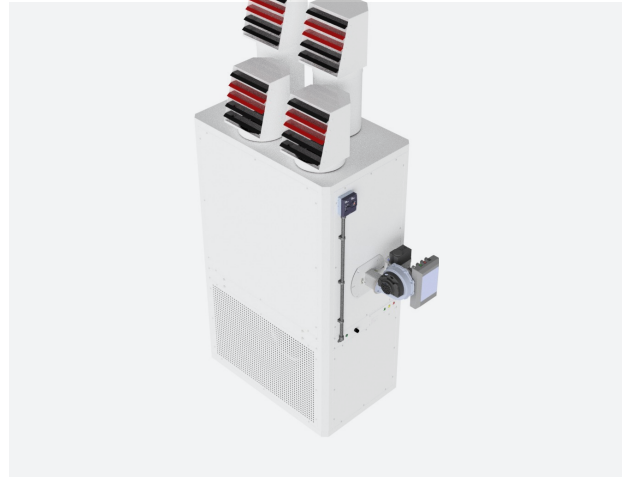

COMET+ CABINET HEATERS

COMET+ STANDARD EFFICIENCY UNIT (INTERNAL)

MODEL	HEAT OUTPUT KW	AIRFLOW (m ³ /h)	Available ESP (pa)	FLUE DIA (mm)	Natural Gas Fired					
					Ducted (D-N)	Nozzled (N-N)	Ducted (D-O)	Nozzled (N-O)	Ducted (D-P)	Nozzled (N-P)
COMET045-2	45.00	3,276	250	100	8489.78	9030.53	8489.78	9030.53	8489.78	9030.53
COMET060-2	60.00	4,392	250	130	8922.38	9463.13	8922.38	9463.13	8922.38	9463.13
COMET090-2	90.00	6,552	250	130	9268.46	9809.21	9268.46	9809.21	9268.46	9809.21
COMET150-2	150.00	10,944	250	130	11463.90	12004.65	11463.90	12004.65	11463.90	12004.65
COMET180-2	180.00	13,104	250	200	12491.33	13302.45	12491.33	13302.45	12491.33	13302.45
COMET210-2	210.00	15,264	250	200	16168.43	17141.78	16168.43	17141.78	16168.43	17141.78
COMET300-2	300.00	21,816	250	250	19683.30	20656.65	19683.30	20656.65	19683.30	20656.65

Please contact sales on 01384 489700 for more information our COMET Cabinet heaters, and the team can provide selection advice.

COMET+ STANDARD EFFICIENCY UNIT (EXTERNAL)

MODEL	HEAT OUTPUT KW	AIRFLOW (m3/h)	Available ESP (pa)	FLUE DIA (mm)	Natural Gas Fired		Oil Fired		Propane LPG Fired	
					Ducted (D-N)	Nozzled (N-N)	Ducted (D-O)	Nozzled (N-O)	Ducted (D-P)	Nozzled (N-P)
COMET045-2-EX	45.00	3,276	250	100	11193.53	11734.28	11193.53	11734.28	11193.53	11734.28
COMET060-2-EX	60.00	4,392	250	130	11626.13	12166.88	11626.13	12166.88	11626.13	12166.88
COMET090-2-EX	90.00	6,552	250	130	11972.21	12512.96	11972.21	12512.96	11972.21	12512.96
COMET150-2-EX	150.00	10,944	250	130	14167.65	14708.40	14167.65	14708.40	14167.65	14708.40
COMET180-2-EX	180.00	13,104	250	200	16817.33	17628.45	16817.33	17628.45	16817.33	17628.45
COMET210-2-EX	210.00	15,264	250	200	20494.43	21467.78	20494.43	21467.78	20494.43	21467.78
COMET300-2-EX	300.00	21,816	250	250	24009.30	24982.65	24009.30	24982.65	24009.30	24982.65

COMET+ HIGH EFFICIENCY/CONDENSING UNIT (INTERNAL)

MODEL	HEAT OUTPUT KW	AIRFLOW (m3/h)	Available ESP (pa)	FLUE DIA (mm)	Natural Gas Fired	
					Ducted (D-N)	Nozzled (N-N)
COMET045-2C	45.00	3,276	250	100	10112.03	11193.53
COMET060-2C	60.00	4,392	250	130	10544.63	11626.13
COMET090-2C	90.00	6,552	250	130	10890.71	11972.21
COMET150-2C	150.00	10,944	250	130	13086.15	14167.65
COMET180-2C	180.00	13,104	250	200	14870.63	16222.50
COMET210-2C	210.00	15,264	250	200	18547.73	20061.83
COMET300-2C	300.00	21,816	250	250	22062.60	23576.70

COMET+ HIGH EFFICIENCY/CONDENSING UNIT (EXTERNAL)

MODEL	HEAT OUTPUT KW	AIRFLOW (m3/h)	Available ESP (pa)	FLUE DIA (mm)	Natural Gas Fired	
					Ducted (D-N)	Nozzled (N-N)
COMET045-2C-EX	45.00	3,276	250	100	12815.78	13897.28
COMET060-2C-EX	60.00	4,392	250	130	13248.38	14329.88
COMET090-2C-EX	90.00	6,552	250	130	13594.46	14675.96
COMET150-2C-EX	150.00	10,944	250	130	15789.90	16871.40
COMET180-2C-EX	180.00	13,104	250	200	19196.63	20548.50
COMET210-2C-EX	210.00	15,264	250	200	22873.73	24387.83
COMET300-2C-EX	300.00	21,816	250	250	26388.60	27902.70

COMET+ CABINET HEATERS

COMET+ FLUE & ACCESSORIES

DESCRIPTION		130mm	200mm	250mm
Starter Kit (Raincap, 1x 1m length, 1x storm collar, 1x Adjustable flashing kit, 1x Flashing fixing kit, 1x Clamp band)	Part No.	CF130-FK-2	CF200-FK-2	CF250-FK-2
	List Price	530.86	578.05	648.83
Universal Raincap	Part No.	CF130-TERM-2	CF200-TERM-2	CF250-TERM-2
	List Price	106.18	133.47	175.94
1m length flue pipe	Part No.	CF130-1M-2	CF200-1M-2	CF250-1M-2
	List Price	116.79	176.96	230.04
0.5m length flue pipe	Part No.	CF130-0.5M-2	CF200-0.5M-2	CF250-0.5M-2
	List Price	76.68	115.27	151.67
90° elbow	Part No.	CFT130-90ELB-2	CFT200-90ELB-2	CFT250-90ELB-2
	List Price	116.79	182.01	380.91
45° elbow	Part No.	CFT130-45ELB-2	CFT200-45ELB-2	CFT250-45ELB-2
	List Price	116.79	182.01	236.61
90° Tee	Part No.	CFT130-90TEE-2	CFT200-90TEE-2	CFT250-90TEE-2
	List Price	182.01	254.81	303.35
Joint clamp band	Part No.	CF130-JC-2	CF200-JC-2	CF250-JC-2
	List Price	23.59	28.31	28.31
Storm Collar	Part No.	CF130-SC-2	CF200-SC-2	CF250-SC-2
	List Price	145.61	145.61	169.87
EPDM Square black Flashing	Part No.	CF130-FF1-2	CF200-FF1-2	CF250-FF1-2
	List Price	115.27	182.01	182.01
Flashing fixing kit	Part No.	CF130-FF-FIX-2	CF200-FF-FIX-2	CF250-FF-FIX-2
	List Price	115.27	252.51	402.31

For 100m flue requirements please see page 18.

NOVAEMS

In addition to controlling, managing and monitoring heating, the innovative system contains a user-friendly panel with the added benefit of remote access.

KEY FEATURES:

HEATING CONTROL

Control and schedule heating with a selflearning system that averages a 43% reduction in energy consumption through greater efficiency.

MULTI-SITE CONTROLS

Schedule the on/off operation to reduce the maintenance and save energy.

REMOTE ACCESS & REPORTING

With a single point of control, view consumption, schedules and more from anywhere with internet access.



NOVA EMS SYSTEM FEATURES	
HEATING CONTROL	REAL TIME MANAGEMENT CONTROL
Scheduling operation of heaters	Easy to navigate user interface
Residual heat utilisation	Cloud based, enabling remote access
Pre-heat optimisation utilising our self learning algorithm	Pre-heat and end time optimisation
Weather compensation	Live data graphs
Accurate temperature control	Password protected access
Process control monitoring to maximise efficiency and safety	Data export
Door switch and failsafe strategy	Site map

NOVAEMS

Please contact sales on 01384 489700 for more information our NOVAEMS, and the team can provide selection advice.



PRODUCT CODES

N-EMS-MP-2	NOVA EMS PANEL
N-EMS-SIM-UK	NOVA EMS - SIM CARD, PLUS LINE RENTAL AND DATA CHARGES FOR ONE YEAR - UK BASED
N-EMS-SIM-EU	NOVA EMS - SIM CARD, PLUS LINE RENTAL AND DATA CHARGES FOR ONE YEAR - EU BASED
N-EMS-SIM-US	NOVA EMS - SIM CARD, PLUS LINE RENTAL AND DATA CHARGES FOR ONE YEAR - US BASED
N-EMS-SE-EXT	NOVA EMS - EXTERNAL TEMPERATURE SENSOR
N-EMS-OS	NOVA EMS - OUTSTATION
N-EMS-SE-INT	NOVA EMS - INTERNAL TEMPERATURE SENSOR
N-EMS-SE-BBS	NOVA EMS - BLACK BULB SENSOR
N-EMS-SW-DS	NOVA EMS - ROLLER SHUTTER DOOR SWITCH
N-EMS-HB	NOVA EMS - HERRINGBONE UNIT
N-EMS-SW-FS	NOVA EMS - SUMMER FAN SWITCH
N-EMS-SW-OS	NOVA EMS - SIMPLE OVERRIDE SWITCH



NOVAEMS

Please contact sales on 01384 489700 for more information our NOVAEMS, and the team can provide selection advice.

SONNIGER LTHW HEATERS



HEATER CONDENS heating and ventilation devices are designed to be applied in buildings of small and medium capacity, especially as production and warehouse halls, car showrooms and service stations, sports halls and stadiums, sacral buildings and churches, retail stores and wholesale outlets, agricultural facilities, exhibition surfaces. HEATER CONDENS is a special, dedicated solution to be connected to low water temperature sources (for condensing boilers, industrial heat pumps).

The main advantages of HEATER CONDENS are the high temperature of exhaust air generated by the low temperature of water supplied to a unit, maximum use of water coil surface – new geometry of coil construction (enhanced fins size, lower space between fins), optimised airflow exhaust – in effect high air exhaust temperature generated on each speed of the fan.



MODEL	DESC.	HEAT OUTPUT RANGE KW	HEAT OUTPUT (70/50°C) ΔT AIR TEMP INCREASE**	NO. OF UNIT ROWS	AIRFLOW - III SPEED (M3/H)	CONNECTION DIAMETER	POWER SUPPLY PARAMETERS (W/A)
SON-WA0015EC	Condens CR One	5 to 25	13kW / 25°C	2	1600	1/2" BSP 124W / 0.58A	16676.74
SON-WA0017EC	Condens CR2	60.00	26kW / 22°C	2	3350	3/4" BSP 250W / 1.08A	17195.86
SON-WA0024	Condens CR2 MAX	90.00	40kW / 22°C	2	5700	3/4" BSP 250W / 2.2A	17611.15

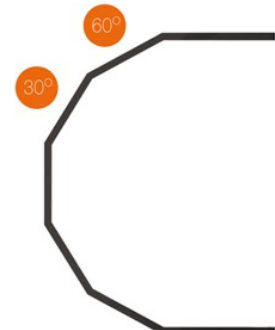

SONNIGER LTHW HEATERS



SONNIGER LTHW HEATERS

SONNIGER HEATER CONDENS

PART NUMBER	DESCRIPTION
SON-WAA0077	SONNIGER HEATER ONE INSTALLATION BRACKET
SON-WAA0028	SONNIGER HEATER CR 2 INSTALLATION BRACKET
SON-WAA0101	SONNIGER HEATER CR 2 MAX INSTALLATION BRACKET
SON-WAA0031	SONNIGER ACTUATOR TS LITE M30X1,5
SON-WAA0032	SONNIGER VALVE ASP/SSP KVS 5,5
SON-CGA0003	SONNIGER 1/2" STRAIGHT VALVE
SON-WAA0067	SONNIGER EXTERNAL SENSOR ES01
SON-WAA0054N	SONNIGER TR 110L PANEL COMFORT SPEED REGULATION AND THERMOSTAT
SON-WAA0035W	SONNIGER INTELLIGENT PANEL RL309 WI-FI
SON-WAA003EC	SONNIGER INTELLIGENT PANEL RL309 WI-FI EC
SON-WAA0055	SONNIGER MULTI 6 AC SPLITTER
SON-WAA0126	SONNIGER MULTI 10 EC SPLITTER

Please contact sales on 01384 489700 for more information on our Sonniger units and our team can provide selection advice.

LIRA

AIR TO AIR HEAT PUMP

In an era of climate transition, Reznor continues to innovate. The new LIRA range delivers powerful and sustainable air-to-air heat pumps, providing gas-free heating and cooling for warehouses and industrial buildings – whisper-quiet and highly efficient, even at temperatures as low as -20°C.

The LIRA range of air-to-air heat pumps is the ideal choice to transition your industrial building to a gas-free heating and cooling solution. Be it a warehouse, a manufacturing facility, or a showroom, LIRA provides year-round comfort focused on sustainability and efficiency.

MODEL RANGE:

- Outdoors: Lira Air, Air Cold & Air Plus
- Indoor: Free Blowing Axial Fan
- Indoor: Ductable Plug Fan.

Furthermore, the LIRA is ready for integration with smart grids and solar energy, allowing you to optimise energy use and reduce dependence on the electricity grid.

LIRA delivers a powerful gas-free solution for heating and cooling in industrial buildings - sustainable, efficient, and ready tomorrow.



FLEXIBLE INSTALLATION & SMART CONTROL

Whether you choose a free-blowing indoor unit with an axial fan or a ducted module with a plug fan, both options are EC-controlled and designed for low noise emission. The outdoor and indoor units can be positioned up to 30 metres apart, and with a single touchscreen panel, you can control up to 15 units. This ensures maximum flexibility and effortless installation.

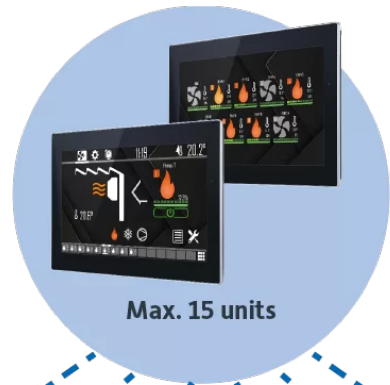

LIRA KEY FEATURES

- Heating mode with a maximum output of 50 kW and a COP of 4.38
- Cooling mode with a maximum output of 42 kW and an EER of 4.00
- Quiet operation: 38 dB(A) @ 5m Outdoor and 30 dB(A) @ 3m Indoor for free blowing units
- R32 refrigerant
- Smart Grid ready – photovoltaic integration
- Simple and quick installation
- Touch control panels

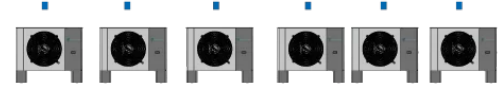

Please contact technical design on 01384 489700 for more information on Air to Air Heat Pumps

LIST PRICE

££POA



DF/IDF GAS FIRED HEATER

The Nordair Niche is back! Powered by Reznor for your heating & ventilation needs. Engineered for high-output performance, this unit delivers exceptional heating while improving air quality and reducing energy costs.

Ideal for large commercial spaces and environments requiring precise humidity control, such as pool facilities, the Nordair Niche offers a robust solution with up to 30% greater efficiency. Direct fired models achieve 100% thermal efficiency, ensuring maximum energy utilization.

With straightforward installation options, including direct refurbishments and like-for-like replacements, the Nordair Niche is a smart upgrade for any HVAC system.

The Nordair Niche delivers efficient, direct gas-fired heating for make-up air applications, maintaining slight positive pressure to control airflow throughout the building. Its fully modulating control

system ensures precise heat delivery with minimal energy use.

Ideal for demanding environments, including swimming pool halls and process ventilation systems, the unit supports optional heat recovery (up to 60%) and variable air volume control, adapting airflow to match extraction rates. This results in significant energy savings while maintaining optimal indoor air quality and pressure balance.

HEAT OUTPUT RANGE:

30kW to 4000kW – (higher outputs available upon request)

TURNDOWN RATIO: Up to 20:1

FUELS: Natural Gas or LPG

MODEL RANGE:

- Direct Fired
- In-Direct Fired
- Make Up Air

NORDAIR NICHE KEY FEATURES

Low Installation Costs

Even Heat Distribution

Rapid Warm-Up

Improved Air Quality

Low Maintenance

Direct fired models – 100% thermal efficiency

Please contact sales on 01384 489700 for more information on our Heating & Ventilation Systems and the team can provide selection advice.

LIST PRICE

££POA

EURO T+ HEATING, VENTILATION & COOLING UNIT

The EuroT+ is the re-engineered evolution of the trusted Euro-T by Reznor, now enhanced with advanced features for superior performance. Designed for versatility, this unit supports a wide range of heating, ventilation, and optional cooling needs across diverse environments.

With seven output ratings and various fuel types available, the EuroT+ offers unmatched flexibility and seamless integration into both existing and new systems, made bespoke to suit any application. Its compact design for easy retro fitting makes it an ideal choice for replacing existing HVAC systems, minimizing installation complexities and downtime.

OUTPUT RANGE: 30–200 kW

FUNCTIONS: Heating, Ventilation, Optional Cooling

FUEL OPTIONS: Natural Gas, LPG, LPHW, Electric

APPLICATIONS: Retrofit & New Installations

MODEL RANGE:

- 7 non-condensing models with heat output ranging from 24–97kW
- 3 fully condensing models with heat output ranging from 54–99kW
- Larger Bespoke models available to 1000kW

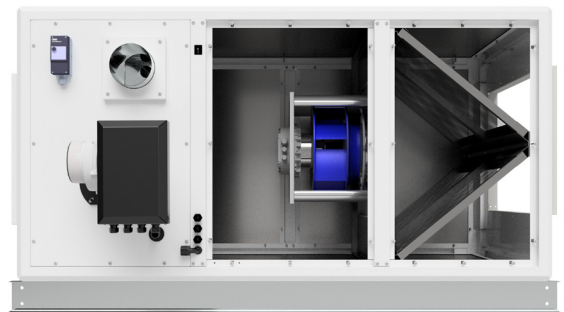

Our advanced heating solutions feature the innovative 4-pass heat exchanger technology, maximizing heat transfer efficiency for superior performance. With versatile options including chilled, cooling, electric, and heat pumps, our systems cater to diverse needs for Heating Ventilation and Cooling.

The EuroT+ has a reliable single burner with multi-try ignition, ensuring consistent performance, while durable stainless steel heat exchangers provide long-lasting durability. The standard modulating burner offers precise control over heat output, complemented by an advanced plug fan with EC control for efficient airflow management.

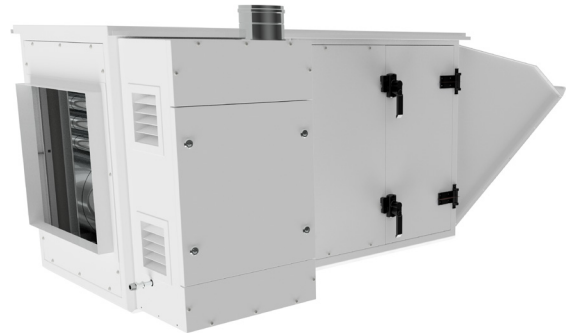

EURO T+ KEY FEATURES

Cost effective compared to a standard AHU

Combined heating & cooling effect – available as Gas, Electric, LPHW

Easy replacement for existing heating and ventilation units

Bespoke design to suit any project

Compatible with the Smartcom3 controller.

Please contact sales on 01384 489700 for more information on our Heating & Ventilation Systems and the team can provide selection advice.

LIST PRICE

£EPOA

RHC⁺

GAS FIRED HEAT MODULE

Back by popular demand, Reznor's RHC+ is the latest generation heat module on the market. Fully packed with net efficiencies of up to 109%, the ultra LowNox RHC+ is ideal for replacing LPHW or electrical coils to gas. With a modular design to fit a wide variety of applications, the RHC+ can easily be retrofitted to replace existing units from other suppliers as well as older RHC appliances.

The RHC+ is next generation of heating modules, ideal for installation in ductwork systems and a variety of industrial applications including drying and curing.

The new and improved RHC+ is Ideal for replacing steam and hot water coils in existing units, enabling the change from central boiler plant to be decentralised gas fired systems.

HEAT OUTPUT RANGE: 10–1000 kW

TURNDOWN RATIO: Up to 18:1

MOUNTING: Internal & External

PACKAGED: Pre-assembled on frame for coil slide installation

MODEL RANGE:

- RHC+ SL WMV - Vertical mounted single module 7 models 30 to 200 kW
- RHC+ SL WMH - Horizontal mounted single module 7 models 30 to 200kW
- RHC+ WMI - Horizontal modules 16 models 30 to 1000 kW
- RHC+ Stacked - Vertical or horizontal.

The RHC+ Gas Fired Heat Module is a high-efficiency, factory-assembled heating solution designed for seamless integration into Air Handling Units (AHUs). Each monobloc unit is fully wired and features burner controls consolidated on a single, easily accessible side for simplified operation and maintenance.

Engineered for both indoor and outdoor use, the RHC+ ensures fast, straightforward installation and optimal energy performance through its wide modulation range and compatibility with various control systems.

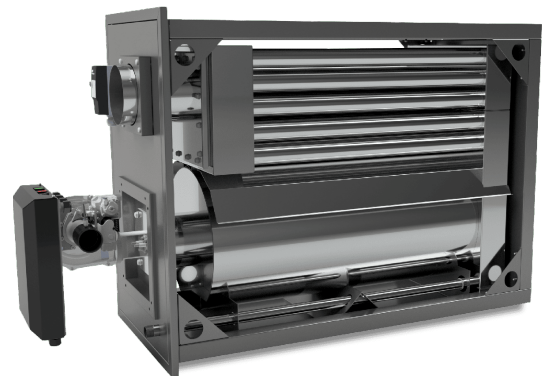

RHC+ KEY FEATURES

Up to 109% net efficiency & Ultra-low Nox

Replaces older RHC4000 & 8000 units & competitor heat modules*

Modular design (Vertical, Horizontal, or Stacked)

High turndown ratio in module format up to 50:1

High temperature heat modules available

High efficiency – condensing or non-condensing

Please contact sales on 01384 489700 for more information on our Heat Module range and the team can provide selection advice.

LIST PRICE

££POA

SURFACE MOUNTED COMMERCIAL AIR CURTAINS

GUARDIAN EC

Guardian EC series are commercial/retail air curtains designed for suspension via optional horizontal or vertical brackets, to serve doors/entrances. Designed with an energy efficient EC fan, the unit uses up to 30% less energy than traditional ac fan motors.

The Guardian EC is made from recyclable materials* and features a sleek RAL 9006 finish, supporting sustainability goals while delivering a modern, visually appealing design.

Comes with Intelligent Wi-fi controller & smart phone app as standard.

Available in three versions:- ambient (unheated), electric (heated) or LPHW (heated)



ELECTRIC (HEATED) MODELS

MODEL	HEAT OUTPUT kW	DOOR WIDTH (mm)	MAX DOOR HEIGHT (mm)	MAX AIRFLOW (m3/h)
GSEC1000E	4/7	1000	4000	2000
GSEC1500E	6.5/11	1500	4000	3600
GSEC2000E	8.5/14	2000	4000	4800

LPHW (HEATED) MODELS

MODEL	HEAT OUTPUT kW	DOOR WIDTH (mm)	MAX DOOR HEIGHT (mm)	MAX AIRFLOW (m3/h)
GSEC1000W	10/16	1000	4000	2000
GSEC1500W	20/29	1500	4000	3600
GSEC2000W	25/40	2000	4000	4800

AMBIENT (NO HEATING) MODELS

MODEL	DOOR WIDTH (mm)	MAX DOOR HEIGHT (mm)	MAX AIRFLOW (m3/h)
GSEC1000A	1000	4000	2100
GSEC1500A	1500	4000	3700
GSEC2000A	2000	4000	5000

GUARDIAN EC OPTIONAL EQUIPMENT

PART NUMBER	DESCRIPTION
GSEC-H-WMB	GUARDIAN EC HORIZONTAL HOLDER SET
GSEC-V-WMB	GUARDIAN EC VERTICAL HOLDER SET

RECESSED COMMERCIAL AIR CURTAINS

GUARDIAN EC

GUARDIAN EC recessed series is expertly engineered to deliver a clean, integrated finish for modern commercial interiors. Designed specifically for flush ceiling installation, the Guardian EC features a complete recessed plate assembly with integrated air inlet and air outlet sections.

Standard colour for the recessed kit is white - RAL Finish to specific colour EPOA. Comes with controller as standard.

Available in three versions:- ambient (unheated), electric (heated) or LPHW (heated)



ELECTRIC (HEATED) MODELS

MODEL	HEAT OUTPUT kW	DOOR WIDTH (mm)	MAX DOOR HEIGHT (mm)	MAX AIRFLOW (m3/h)
GREC1000E	4/7	1000	4000	2000
GREC1500E	6.5/11	1500	4000	3600
GREC2000E	8.5/14	2000	4000	4800

LPHW (HEATED) MODELS

MODEL	HEAT OUTPUT kW	DOOR WIDTH (mm)	MAX DOOR HEIGHT (mm)	MAX AIRFLOW (m3/h)
GREC1000W	10/16	1000	4000	2000
GREC1500W	20/29	1500	4000	3600
GREC2000W	25/40	2000	4000	4800

AMBIENT (NO HEATING) MODELS

MODEL	DOOR WIDTH (mm)	MAX DOOR HEIGHT (mm)	MAX AIRFLOW (m3/h)
GREC1000A	1000	4000	2100
GREC1500A	1500	4000	3700
GREC2000A	2000	4000	5000

GUARDIAN EC OPTIONS

PART NUMBER	DESCRIPTION
340.RAL	Finish to RAL colour - 1m
340.RAL	Finish to RAL colour - 1.5m
340.RAL	Finish to RAL colour - 2m

GUARDIAN OPTIONS

PART NUMBER	DESCRIPTION
1039064	GUARDIAN EC Multi 10 EC Splitter
1039065	GUARDIAN EC Door Switch



SURFACE MOUNTED MODEL

WIRED CONTROLLER

RECESSED MODEL

COMMERCIAL AIR CURTAINS

AC & ACR MINI

AC & ACR Mini series are commercial/retail air curtains designed for use over doors, mounted on walls or ceiling (AC). The ACR model allows positioning in a suspended ceiling or bulhead above doorways where low visual impact is required. All models include electric heating as standard.

SURFACE MOUNTED (ELECTRIC 1PH) - WIRED CONTROLLER READY

MODEL	HEAT INPUT	DOOR WIDTH (mm)	MAX DOOR HEIGHT (mm)	MAX AIRFLOW (m3/h)
MINI600SE3-RX	33.0	600	1800	273
MINI800SE4-5-RX	4.5	800	2700	382
MINI1000SE6-RX	6.0	1000	3600	382
1Z-RX		Wired controller (up to 16 units)		

RECESSED (ELECTRIC 1PH) - WIRED CONTROLLER READY

MODEL	HEAT INPUT	DOOR WIDTH (mm)	MAX DOOR HEIGHT (mm)	MAX AIRFLOW (m3/h)
ACRMINI3-RX	600	600	1800	180
ACRMINI4-5-RX	800	800	2700	216
ACRMINI6-RX	1000	900	3600	432
1Z-RX		Wired controller (up to 16 units)		



INDUSTRIAL AIR CURTAINS

ACT SERIES

ACT series is an electric heater that directs a downflow of warm air from overhead.

Available as either a recessed or surface mounted models.

RECESSED (ELECTRIC 1PH) - WIRED CONTROLLER READY

MODEL	HEAT INPUT	DIMENSIONS (mm)	MOUNTING HEIGHTS (mm)
ACT03R-RX	33.0	220H x 600W x 600D	3000
ACT04R-RX	4.5	220H x 600W x 600D	3500
ACT06R-RX	6.0	220H x 600W x 600D	3500
1Z-RX	Wired controller (up to 16 units)		

SURFACE MOUNTED (ELECTRIC 1PH) - WIRED CONTROLLER READY

MODEL	DESCRIPTION
ACTKIT-1	Surface Mounted Kit

INDUSTRIAL AIR CURTAINS

AB

AB industrial air curtains are for horizontal use above doors up to 6.0m high and available from 1.75m wide up to 6.75m. They are available in ambient (unheated), gas heated, electric heated and LPHW heated versions, with steam heated versions available on request. Control panels are available as an option.

Electric and Ambient AB Air Curtains can also be mounted vertically.

NOTE: AB Air Curtains are made up of 1.75m & 2.25m size modules. Please see table on page 38 for unit make-up.



AMBIENT (NO HEATING)

MODEL	NO OF MODULES	MAX DOOR HEIGHT (m)	LENGTH (m)	QTY OF BRACKETS FOR VERTICAL MODELS
45-AB175A-2	1	6.0	1.75	2
45-AB225A-2	1	6.0	2.25	2

LPHW HEATED

MODEL	NO OF MODULES	HEAT INPUT kW	MAX DOOR HEIGHT (m)	LENGTH (m)	TEMP RISE °C
45-AB175W-2	1	60.0	6.0	1.75	16
45-AB225W-2	1	70.0	6.0	2.25	16

GAS HEATED

MODEL	NO OF MODULES	HEAT INPUT kW	MAX DOOR HEIGHT (m)	LENGTH (m)	TEMP RISE °C
45-AB175N-2	1	40.0	6.0	1.75	12
45-AB225N-2	1	54.0	6.0	2.25	12

ELECTRIC HEATED

MODEL	NO OF MODULES	HEAT INPUT kW	MAX DOOR HEIGHT (m)	LENGTH (m)	TEMP RISE °C
45-AB175E-2	1	18.0	6.0	1.75	16
45-AB225E-2	1	24.0	6.0	2.25	16



Single module

Double module

UNIT MAKE-UP

AB175 = 1 x AB175

AB225 = 1 x AB225

AB350 = 2 x AB175

AB400 = 1 x AB175 + 1 x AB225

AB450 = 2 x AB225

AB525 = 3 x AB175

AB575 = 2 x AB175 + 1 x AB225

AB625 = 1 x AB175 + 2 x AB225

AB675 = 3 x AB225

AB ACCESSORIES

PART NUMBER	DESCRIPTION
CP-AB-AMBI	Ambient models controller
CP-ABGAS-SINGLE-2	Gas models controller (1 module)
CP-ABGAS-TWIN-2	Gas models controller (2 module)
CP-ABGAS-TRIPLE-2	Gas models controller (3 module)
1030251	Electric models controller AB175
1030252	Electric models controller AB225
1030253	Electric models controller AB350
1030254	Electric models controller AB400
1030255	Electric models controller AB450
1030256	Electric models controller AB525
1030258	Electric models controller AB625
1030259	Electric models controller AB675
CP-AB-LPHW-SINGLE	LPHW models controller (1 module)
CP-AB-LPHW-TWIN	LPHW models controller (2 module)
CP-AB-LPHW-TRIPLE	LPHW models controller (3 module)
N1611	Door Switch - All Controllers
N7041	Room Thermostat - All Controllers
6500-1	3/4" Flexible gas connection for AB gas models
6510	3/4" BSP Gas valve for AB Gas models

CARRIER CHARGES

RADIANT HEATING EQUIPMENT

MODELS

Vision, Sonning², SCR-ECO, Electric Quartz, Nor-Ray-Vac

All models carriage charged at 8% of net invoice.
[min. charge £200.00, maximum charge £1200.00 per delivery]

Ventilation, Heat Modules & Heat Pumps - EPOA

WARM AIR UNIT EQUIPMENT

MODELS	SIZE	QUANTITY		
		1	2-4	5+
RHeco	25-50 75-100	£POA £POA	£POA £POA	£POA £POA
PHOTON	10-45 55-100	£POA £POA	£POA £POA	£POA £POA
e+	All Models (Next Day Delivery)	£POA £POA	£POA	£POA

MODELS	SIZE	QUANTITY			
		1	2-3	4-5	6+
COMET+	45-150 180-300	£POA £POA	£POA £POA	£POA £POA	£POA £POA

DESTRATIFICATION FANS

MODELS	DELIVERY OPTIONS	QUANTITY		
		1	2-4	5+
All Models	Next Day	£POA	£POA	£POA

COMMERCIAL AIR CURTAINS

MODELS	DELIVERY OPTIONS	QUANTITY		
		1	2-4	5+
Guardian EC, AC / ACR Mini, ACT	Next Day Next Day	£POA £POA	£POA £POA	£POA £POA
All Models	Next Day Before 9:00am	£POA	£POA	£POA

CARRIER CHARGES

INDUSTRIAL AIR CURTAINS

MODELS	NO. OF MODULES	QUANTITY		
		1	2-4	5+
AB	1	EPOA	EPOA	EPOA
	2	EPOA	EPOA	EPOA
	3	EPOA	EPOA	EPOA

FLUE

DESCRIPTION	
Flue only	All flue carriage charge 6% of net invoice (min. charge £35.00)
Flue shipped with heater orders	Free of charge

Off-loading is the responsibility of the customer, if you require special off-loading facilities please call the UK sales office on 01384 489 700.

Carriage Charge Information

- UK mainland only, other destinations P.O.A
- Hiab and other special requirements P.O.A
- All prices ex-works Brierley Hill
- All equipment sold subject to Conditions of Sale
- Transport charges are not subject to trade discount
- Carriage charges maybe subject to a fuel surcharge
- All prices based upon 3 working day delivery unless specified; next working day delivery add £35.00 per unit
- Next day deliveries based on ex-stock units being delivered next working day on orders received before 12.00 noon.

TERMS & CONDITIONS

We will confirm a site date upon receipt of full instructions and paperwork.

No order shall be binding until acknowledged by Nortek Global HVAC in writing.

The products covered by this price list are all deemed to be of standard colour, duty and specification.

All prices are ex-works. Carriage will be charged at the rate ruling at date of despatch.

Minimum order charge £25.00 plus p&p on small items.

VAT will be additionally charged at the ruling rate on date of invoice.

PAYMENT TERMS

30 days from date of invoice for approved accounts. Payment prior to despatch and early payment discounts quoted upon request.

RETURNS POLICY

We hope you will be completely satisfied with any product or component purchased from Nortek Global HVAC UK Ltd, but if you wish to return an item, we aim to make it as quick and convenient as possible.

RETURNS PROCESS

Please call 01384 489 700 and select from one of the options for the relevant product return.

Please have your return details ready and our trained staff will guide you through the process. On acceptance a returns material authorisation number will be given which must be included both on the packaging and returns paperwork. Upon the issuing of an RMA number, goods must be returned to us within 10 working days. We are unable to process any goods returned without an RMA number.

Not all requests to return goods will be accepted.

DAMAGED IN TRANSIT

If you take delivery of a product that has been damaged in transit, the goods must be checked and any damage reported in writing within 3 working days. Claims made outside this period will not be considered. The product then requires return/collection within 10 working days.

RETURN OF FAULTY GOODS

Should a fault develop with a product purchased from us within the first year of ownership, please contact our Service department with details of the fault and we will advise you how to proceed. Nortek Global HVAC UK Ltd reserves the right to either replace or repair faulty item[s]. Should we deliver a replacement item we will invoice for it, crediting the faulty item upon receipt.

ORDERED INCORRECTLY/INCORRECTLY SUPPLIED/NOT REQUIRED

If an item has either been ordered incorrectly, incorrectly supplied or is not required, it can be returned within 30 days from purchase as long as it remains unused, in new condition and with all packaging and labels intact. Should Nortek Global HVAC UK Ltd incur any costs in re-working or re-packaging the returned items to a re-saleable condition, this will affect the amount of credit due.

Returned items that have been ordered incorrectly or are not required will incur a 25% restocking charge. If these items are collected, a collection charge will also apply. Heaters built to customer specification will not be eligible for return; any cancellation prior to despatch will be subject to a charge relevant to costs incurred.

EXCESS ITEMS

Nortek Global HVAC UK Ltd systems are designed using the information available to us at the time. Due to the high cost of handling and risk of damage, it is not possible for excess Nor-Ray-Vac, herringbone materials or warm air flue to be returned for credit.

DELIVERY DATES

All dates quoted for delivery are approximate only and Nortek Global HVAC UK Ltd shall not be liable for the delay in delivery of goods however caused. You are advised to ensure that goods have been delivered to the required location before committing labour.

RADIANT HEATER STILLAGE

For large radiant heater orders, components are delivered on stillages, which should be unloaded upon receipt and returned to the delivery vehicle. Failure to do so will result in additional charges to collect and return stillage[s].

COVERED UNDER OUR STANDARD WARRANTY

ALL HEATERS, CONTROLS AND ACCESSORIES SUPPLIED AS PART OF A NEW HEATING SYSTEM

WARRANTY	
Labour	1st Year
Parts - Excludes consumables (i.e belts, filters, fuses, Quartzglow bulbs etc)	1st and 2nd Year
Access equipment and tool hire	1st Year
Carriage cost for replacements	1st Year

EXCEPTIONS FOR NEW INSTALLATIONS

DESCRIPTION	
DS destratification fans	1st Year (parts only)

SPARE PARTS

WARRANTY	
Controls and accessories supplied as spares (excl consumables)	1st Year
General spare parts (excl consumables)	1st and 2nd Year
Carriage cost for replacement spares	1st Year
Labour for replacement spares	1st Year

STANDARD WARRANTY PERIOD

DATE OF START

From date of despatch or commissioning date (if no more than 90 days from date of despatch and conducted by a Nortek Global HVAC UK Service Engineer) Commissioning report and documentation will be required.

WHO IS COVERED?

WHO HOLDS THE WARRANTY?

The purchasing customer account holds the warranty.

PAYMENT OF ITEMS IN WARRANTY

Payment has to either have been settled or still be within the agreed account payment terms e.g. an account with a 30 day payment term.

COMMISSIONING AND SERVICE OF UNITS

Proof of commissioning and annual service reports must be supplied by the customer.

NOT COVERED

Unauthorised modifications to equipment

PAYMENTS

WARRANTY PARTS ONLY REQUEST

Customers requesting parts only will be invoiced for the items and carriage. Upon return and our receipt of the

faulty items and our agreement as to the warranty, a credit for the value of the invoice will be made.

UNDER WARRANTY ENGINEER SITE VISITS

We will send a 'Warranty' form, this should be completed and returned with an order for site attendance. Customers will only be charged if the call out is not covered by warranty and after full negotiation between ourselves and the customer.

CASH CUSTOMERS

Cash customers should pay pro-forma for the day labour rate and any parts that may be required. If the call-out is found to be covered by warranty then a credit for all items covered by the warranty will be issued.

STANDARD CALL-OUT POLICY

ENGINEER CALL-OUTS

We aim to attend site upon receipt of full instructions and paperwork. We will however do all we can to meet any specific customer requirements.

OPTION 1 SALES

reznorsales@nortek.com

- Pricing, Orders and Quotes
- Technical Designs & Support (pre-sales)
- Spares & Equipment

OPTION 2 POST SALES TECHNICAL SUPPORT

uk.hvac.techsupport@nortek.com

- Installation Support
- Wiring Advice
- Trouble Shooting

OPTION 3 SERVICE

serviceuk.hvac@nortek.com

- General Service Support
- Warranty Call Outs
- Arrange Commissioning

OPTION 4 ACCOUNTS & SUPPLY CHAIN

hvacuk.creditcontrol@nortek.com

- Credit Limit Advice
- Opening a New Account
- Invoicing

REZNOR®

REZNOR.CO.UK | REZNORSALES@NORTEK.COM | 01384 489700

Registered in England No. 01390934 | Registered Office: Nortek Global HVAC UK Limited, Fens Pool Avenue, Brierley Hill, West Midlands, DY5 1QA

Nortek Global HVAC is a registered trademark of Nortek Global HVAC Limited. Because of continuous product innovation, Nortek Global HVAC reserves the right to change product specification without due notice.

ALL PRICES ARE EX WORKS | E&OE