

# GUARDIAN EC™



## COMMERCIAL AIR CURTAINS

PRODUCT GUIDE - SURFACE MOUNTED

**REZNOR®**

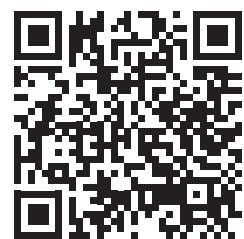

VIEW IN 3D

# KEEP COMFORT IN. KEEP ENERGY COSTS DOWN.

Smart efficiency, quieter performance, seamless control.

The GUARDIAN EC™ Air Curtain is a smart, high-performance air curtain designed for modern commercial buildings, combining advanced EC fan technology with intelligent airflow and heating to maintain indoor comfort and cut energy use. Suitable for mounting heights up to 4m, it delivers quiet operation and precise control via touchscreen or smartphone app, providing a barrier that prevents the ingress of outdoor air even at the busiest entrances while meeting the latest European Ecodesign standards.



experience up to

**30%**  
less

energy use  
than AC fans

## Model Range

### STANDARD:

Surface-mounted

### LENGTHS:

1m, 1.5m, 2m

## Types

- Electric heated (3-phase to heater)
- Ambient (non-heated)
- Low-temperature hot water

**Finish:** RAL 9006

## Features & Benefits

- Airflow: 2,000–4,800 m<sup>3</sup>/hr
- WiFi touchscreen & smartphone app
- Quiet, lightweight, low maintenance
- Simple installation
- Alternative to gas technology
- Made from recyclable materials\*

## Applications

- Supermarkets & large retail spaces
- Car showrooms & service stations

## Options & Accessories

- Horizontal and vertical mounting brackets
- Magnetic door switch
- LTHW water control valve
- Splitter box allowing control of up to 10 units

### ADVANCED HEATING TECHNOLOGY

- 3-phase PTC ceramic heating element
- Self-regulating heat output
- Improved energy efficiency
- Fast, responsive warm-up
- Enhanced safety and extended service life.



**Safe, efficient heating**  
optimised for peak and  
off-peak use.

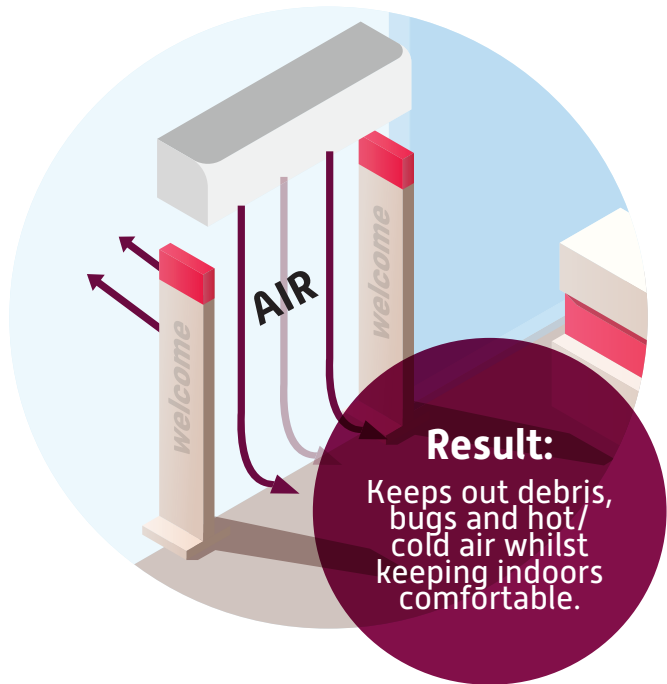

### Result:

Keeps out debris,  
bugs and hot/  
cold air whilst  
keeping indoors  
comfortable.

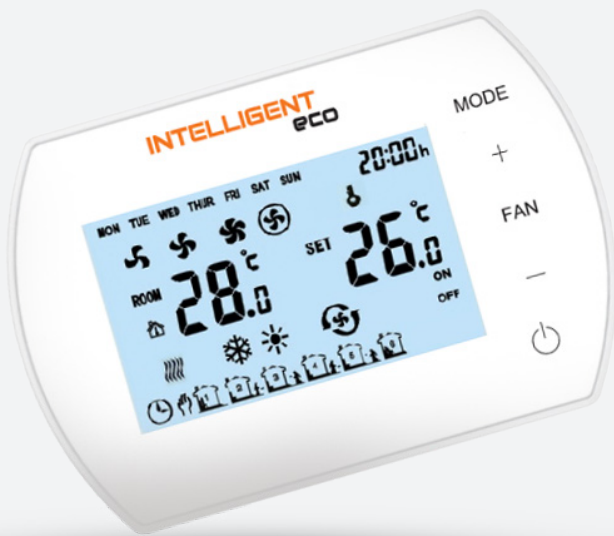

## Intelligent WiFi Controller

Smart automation maintains consistent comfort and optimises energy use:

- Controls up to 3 units
- Touchscreen
- Built-in temperature sensor with frost protection
- Heating, free cooling & ventilation modes
- Weekly time operation (5/1/1 days)
- Auto/Manual multi-speed fan
- BMS-MODBUS compatible
- Full monitoring via TUYA SMART app

## Operation

Adjust fan speed, valves and actuators (LTHW versions only) based on indoor temperature, increasing airflow when rooms are cold and reducing it as the setpoint is reached.



**VIEW IN 3D**

# Technical Data

TYPE	AIR CURTAINS WITH WATER HEATER			AIR CURTAINS WITH ELECTRIC HEATER			AIR CURTAINS WITHOUT HEATER		
	GSEC1000W	GSEC1500W	GSEC2000W	GSEC1000E	GSEC1500E	GSEC2000E	GSEC1000A	GSEC1500A	GSEC1500A
Unit Length	1m	1.5m	2m	1m	1.5m	2m	1m	1.5m	2m
Effective Range	4m	4m	4m	4m	4m	4m	4m	4m	4m
Heat Output Range	10-16 kW	20-29 kW	25-40 kW	4-7 kW	6.5-11 kW	8.5-14 kW	-	-	-
Max. Air Output	2000 m <sup>3</sup> /h	3600 m <sup>3</sup> /h	4800 m <sup>3</sup> /h	2000 m <sup>3</sup> /h	3600 m <sup>3</sup> /h	4800 m <sup>3</sup> /h	2100 m <sup>3</sup> /h	3700 m <sup>3</sup> /h	5000 m <sup>3</sup> /h
Diameter of Connection Nozzles	1/2"	1/2"	1/2"	-	-	-	-	-	-
Supply Voltage [V/Hz/A]	230/50 1.4 A	230/50 1.8A	230/50 2.4A	3x400/50 14A	3x400/50 21A	3x400/50 27.5A	230/50 1.4 A	230/50 1.8A	230/50 2.4A

Additional technical data can be found in the product manual.

## Dimensions

GUARDIAN EC 1000-1500-2000 W,E, A CURTAINS

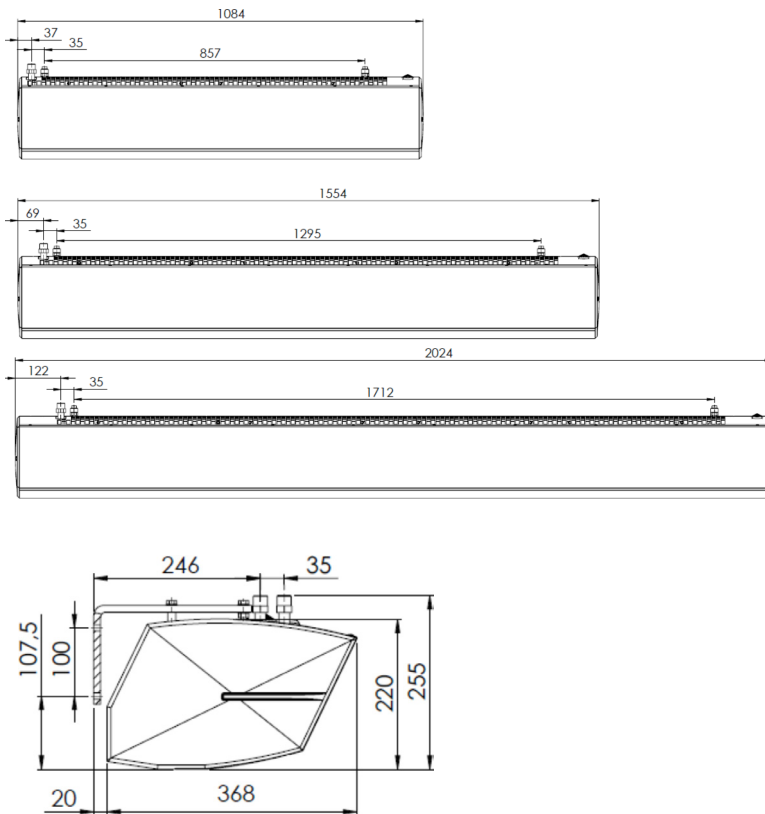

## Technical Performance

HORIZONTAL AIRFLOW RANGE  
(max range for horizontal installation)

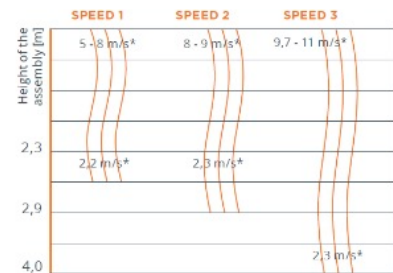

VERTICAL AIRFLOW RANGE  
(max range for vertical installation)  
+ air flow speed

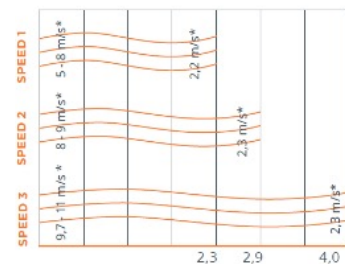

**REZNOR**<sup>®</sup>

t. +(44) 0 1384 489700  
e. [reznorsales@nortek.com](mailto:reznorsales@nortek.com)  
w. [reznor.co.uk](http://reznor.co.uk)

Nortek Global HVAC UK  
Fens Pool Avenue, Brierley Hill  
West Midlands DY5 1QA  
United Kingdom