

## INSTALLATION INSTRUCTION FLUE ADAPTER KIT VISION VSX RADIANT TUBE HEATER Part Number 201889

The Vision VSX Flue Adapter Kit contains the following:-

- 1 off 5" to 4" reducer, 201320, item K
- 1 off Flexible hose, 201321, item H
- 2 off Hose clips, 7541, item G
- 3 off Drill screws, N0213, not shown

Note:- Refer to diagrams 1 and 2 overleaf for references.

To fit the kit:-

1. Remove heat exchanger (F) flue shroud (M) by unscrewing 2 screws. Replace screws after shroud removal to cover holes.
2. Attach flexible hose (H) over flared heat exchanger flue outlet collar. Secure in place with hose clip (G).
3. Fit 100mm end of reducer (K) to other end of flexible hose (H) and secure with hose clip (G).
4. Attach 125mm end of reducer (K) to twin wall flue pipe (L) using high temperature silicone sealant and 3 off supplied drill screws.

Note:- Refer to diagrams 1 and 2 overleaf for references.

**Diagram 1 Forced Burner with Heat Exchanger (Standard Flue)  
for flue products of combustion and no ducted air**

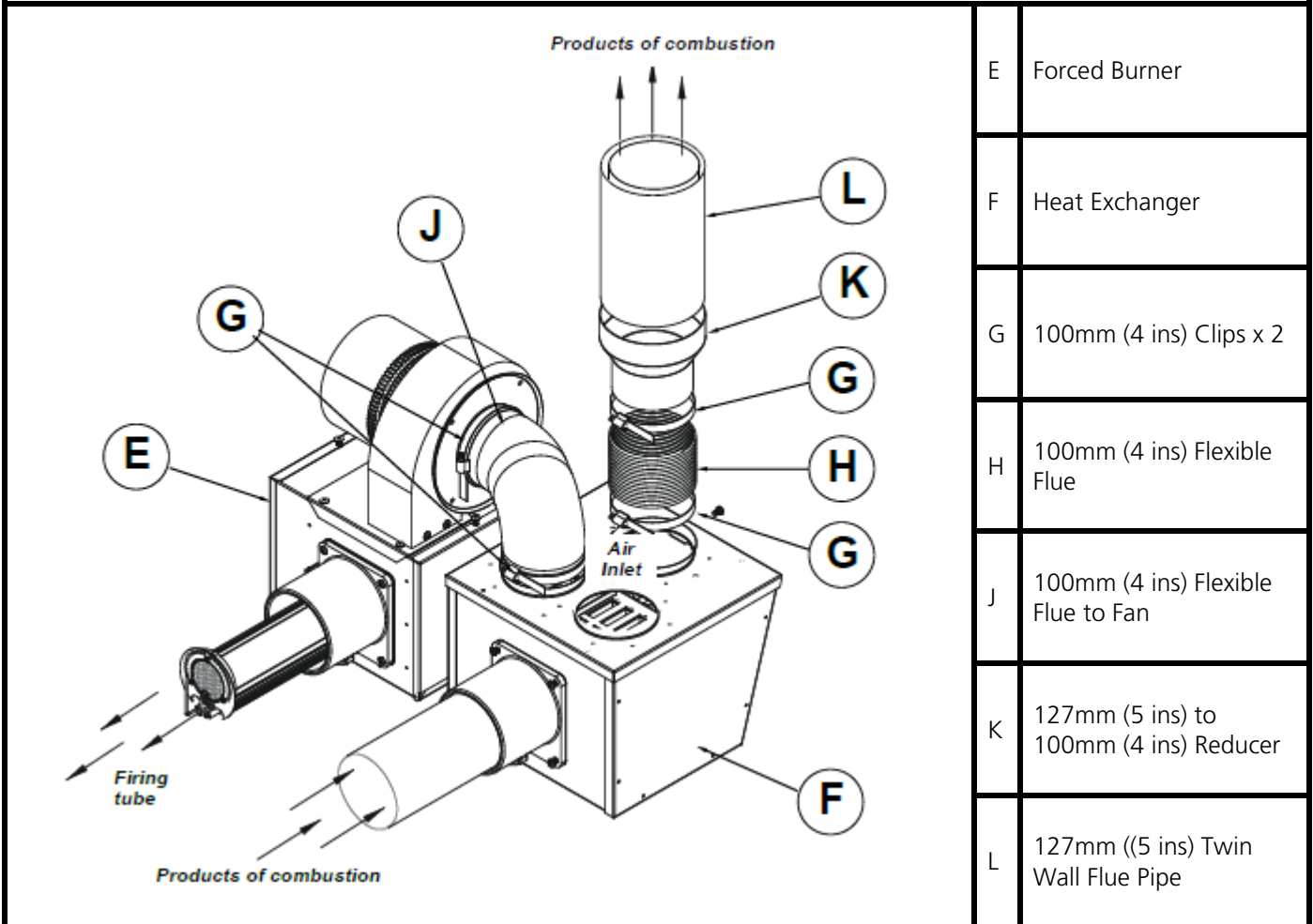

Maximum flue length = 9.5m @ Ø  
 Maximum number of bends in flue = 2  
 All flues must terminate vertically  
 For further information on flue runs, please refer to section 1.9.1 of BS 5440 Pt. 1



Ducted air must be used in locations where there is airborne dust or where there is a polluted atmosphere e.g. Chlorinated Vapours.



Maximum length of duct = 9m  
 Minimum diameter of duct = 100mm  
 Maximum number of bends in duct = 2



Ventilation requirements are as detailed in section 1.7 of the VSX Radiant Heater Installation Manual, Reznor document number D301038

**Diagram 2 Forced Burner with Heat Exchanger (No External Flue)  
for ducted air and products of combustion to ventilated area**

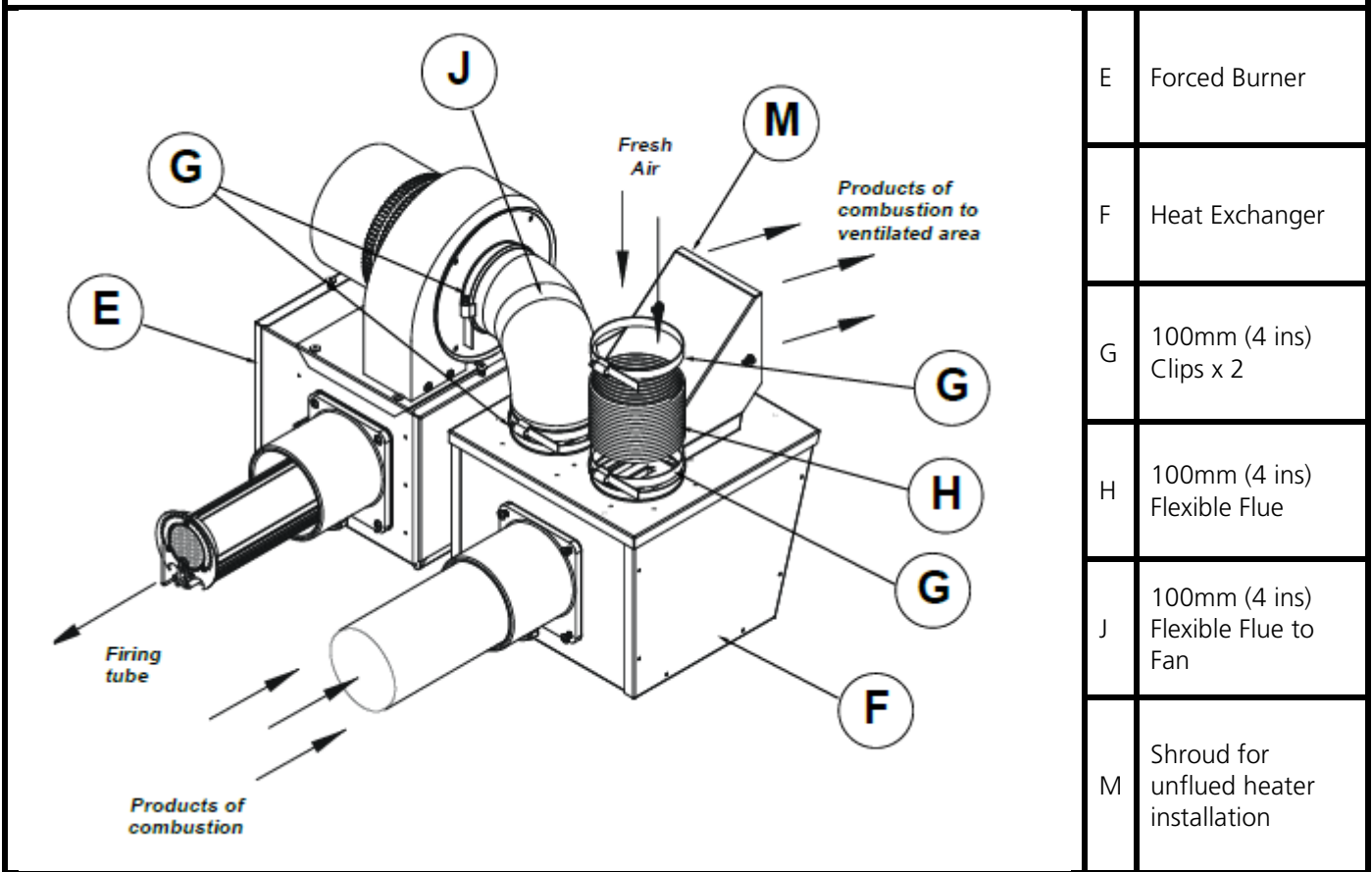

Ducted air must be used in locations where there is airborne dust or where there is a polluted atmosphere e.g. Chlorinated Vapours.



Maximum length of duct = 9m  
Minimum diameter of duct = 100mm  
Maximum number of bends in duct = 2



Ventilation requirements are as detailed in section 1.7 of the VSX Radiant Heater Installation Manual, Reznor document number D301038

# REZNOR®

**NORTEK GLOBAL HVAC (UK) LTD**

Fens Pool Avenue  
Brierley Hill  
West Midlands DY5 1QA  
United Kingdom  
Tel +44 (0)1384 489700  
Fax +44 (0)1384 489707  
reznorsales@nortek.com  
www.reznor.eu

Current full Part No.

Installation Instruction  
Vision VSX Flue Adapter Kit  
EN October 2022 D301516 Issue 0

**NGH**  
NORTEK GLOBAL HVAC™

Nortek Global HVAC is a registered trademark of Nortek Global HVAC Limited. Because of the continuous product innovation, Nortek Global HVAC reserves the right to change product specification without due notice.