

## CABINET HEATER CONVERSION

### from a VERTICAL into a HORIZONTAL MODEL

To convert cabinet air heaters from a vertical into a horizontal model, the following procedure is necessary assuming that a basic (no options) air heater is the starting point.

**Note :**

Components referred to are given the description of those of the vertical models e.g. bottom plate and end plate horizontal are similar parts etc.

1. **A basic kit of parts, part number 03 FS001\_00, comprising following components is necessary :**
  - Quantity 2, hanger angles middle (part number 90 76079)
  - Quantity 2, lower corner profiles horizontal (part number.90 76021)
  - Limit control protection shield (part number 90 71281)
  - Quantity 8, fixing screws (part number 60 62922 6x16)
  - Quantity.2 fixing "pop" rivets (part number 60 70545)

Dependant on final configuration required necessary panels should be ordered as spare parts in accordance with the table below.
  
2. Refer to figure 1 for vertical unit standard configuration (no options) reference
  - 2.1 Remove, turn and replace key 7 flue protection cover
  - 2.2 Remove key 1 suspension brackets
  - 2.3 Remove key 2 lower corner profiles
  - 2.4 Remove key 5 side panels (perforated) on frames size I & size II
  - 2.5 Remove keys 4 and 5 lower rear and side panels (perforated) on frames size III thru size V
  - 2.6 Remove key 3 bottom plate blind (not painted)
  
3. Refer to figure 2 for horizontal unit standard configuration reference (e.g. : open end air inlet with perforated plate)
  - 3.1 Replace suspension brackets and lower corner profiles keys 1 and 2 adding the components of the basic kit of parts key 9 as illustrated.
  - 3.2 Fit perforated bottom plate key 8.
  - 3.3 Fit lower back and side panels keys 4 and 5 thus creating horizontal air intake end. **Special operation for frame size V is required : fit cover plate key 7 over perforated section of lower front panel key 6.**
  - 3.4 This completes to conversion to a basic horizontal air heater.
  
4. Refer to figure 2 for conversion of a standard vertical air heater into a horizontal air heater with ducted air inlet end (= option FS 541.4)
  - 4.1 Replace suspension brackets and lower corner profiles keys 1 and 2 adding the components of the basic kit of parts key 9 as illustrated.
  - 4.2 Fit lower back and side panels keys 4 and 5 thus creating horizontal air intake end. **Special operation for frame size V is required : fit cover plate key 7 over perforated section of lower front panel key 6.**
  - 4.3 This completes to conversion to a horizontal air heater with ducted air inlet end.
  
5. Refer to figure 2 for the conversion of a standard vertical air heater into a horizontal air heater with ducted air inlet top (= option FS 541.5).
  - 5.1 Replace suspension brackets and lower corner profiles keys 1 and 2 adding the components of the basic kit of parts key 9 as illustrated.
  - 5.2 Fit (painted) bottom panel key 3.
  - 5.3 Fit lower back panel key 4 and side panel key 5 thus creating horizontal air intake top. **Special operation for frame size V is required : fit cover plate key 7 over perforated section of lower front panel key 6.**
  - 5.4 This completes to conversion to a horizontal air heater with ducted air inlet top.

6. Refer to figure 2 for the conversion of a standard vertical air heater into a horizontal air heater with ducted air inlet rear (= option FS 541.6).
  - 6.1 Replace suspension brackets and lower corner profiles *keys 1 and 2* adding the components of the basic kit of parts *key 9* as illustrated.
  - 6.2 Fit (painted) bottom panel *key 3*.
  - 6.3 Fit lower side panels *key 5* thus creating horizontal air intake rear. **Special operation for frame size V is required** : fit cover plate *key 7* over perforated section of lower front panel *key 6*.
  - 6.4 This completes to conversion to a horizontal air heater with ducted air inlet rear.
  
7. Refer to figure 2 for the conversion of a standard vertical air heater into a horizontal air heater with ducted air inlet bottom (= option FS 541.7).
  - 7.1 Replace suspension brackets and lower corner profiles *keys 1 and 2* adding the components of the basic kit of parts *key 9* as illustrated.
  - 7.2 Fit (painted) bottom panel *key 3*.
  - 7.3 Fit lower back panels *key 4* & side panel *key 5* thus creating horizontal air intake bottom. **Special operation for frame size V is required** : fit cover plate *key 7* over perforated section of lower front panel *key 6*.
  - 7.4 This completes to conversion to a horizontal heater with ducted air inlet bottom.

**Table of parts list descriptions & part numbers necessary for conversion and applying options**

#	Model	Fig./Key	Description	Part number	Qty
1	All	9	Kit of parts	03 FS001 00	1
2	Kit content	2-9	Lower corner profile	90 76021	2
3	Kit content	2-9	Hanger angle middle	90 76079	2
4	Kit content		Screws for items 2 & 3	06 62922 6x16	8
5	Kit content	2-10	Control protection shield	90 71281	1
6	Kit content		Rivets to fix item 5 above	60 70545	2
7	Frame I	1-3	Bottom plate (no paint)	90 76000 NP	1
8	Frame II	1-3	Bottom plate (no paint)	90 76200 NP	1
9	Frame III	1-3	Bottom plate (no paint)	90 76400 NP	1
10	Frame IV	1-3	Bottom plate (no paint)	90 76600 NP	1
11	Frame V	1-3	Bottom plate (no paint)	90 76800 NP	1
12	Frame I	1-4	Lower rear panel perforated	90 76004	1
13	Frame II	1-4	Lower rear panel perforated	90 76204	1
14	Frame III	1-4	Lower rear panel perforated	90 76404	1
15	Frame IV	1-4	Lower rear panel perforated	90 76604	1
16	Frame V	1-4	Lower rear panel perforated	90 76804	1
17	Frame I	1-5	Lower side panels (perforated)	90 76003	2
18	Frame II	1-5	Lower side panels (perforated)	90 76203	2
19	Frame III	1-5	Lower side panels (perforated)	90 76403	2
20	Frame IV	1-5	Lower side panels (perforated)	90 76603	2
21	Frame V	1-5	Lower side panels (perforated)	90 76803	2
22	Frame I	2-8	Bottom plate (perforated horizontal)	90 76114	1
23	Frame II	2-8	Bottom plate (perforated horizontal)	90 76314	1
24	Frame III	2-8	Bottom plate (perforated horizontal)	90 76514	1
25	Frame IV	2-8	Bottom plate (perforated horizontal)	90 76714	1
26	Frame V	2-8	Bottom plate (perforated horizontal)	90 76914	1
27	Frame I	2-3	Bottom plate (Vertical painted)	90 76000	1
28	Frame II	2-3	Bottom plate (Vertical painted)	90 76200	1
29	Frame III	2-3	Bottom plate (Vertical painted)	90 76400	1
30	Frame IV	2-3	Bottom plate (Vertical painted)	90 76600	1
31	Frame V	2-3	Bottom plate (Vertical painted)	90 76800	1
32	Frame I	2-4	Lower rear panel (horizontal)	90 76004	1
33	Frame II	2-4	Lower rear panel (horizontal)	90 76204	1
34	Frame III	2-4	Lower rear panel (horizontal)	90 76520	1
35	Frame IV	2-4	Lower rear panel (horizontal)	90 76720	1
36	Frame V	2-4	Lower rear panel (horizontal)	90 76920	1
37	Frame I	2-5	Lower side panel (horizontal)	90 76044	2
38	Frame II	2-5	Lower side panel (horizontal)	90 76318	2
39	Frame III	2-5	Lower side panel (horizontal)	90 76518	2
40	Frame IV	2-5	Lower side panel (horizontal)	90 76718	2
42	Frame V	2-5	Lower side panel (horizontal)	90 76918	2
43	Frame V	2-6	Lower front panel (vert. perforated)	90 76806	1
44	Frame V	2-7	Lower front panel cover plate	90 76806 01	1

Figure 1 : Standard configuration

0009KTF50Q1-EN

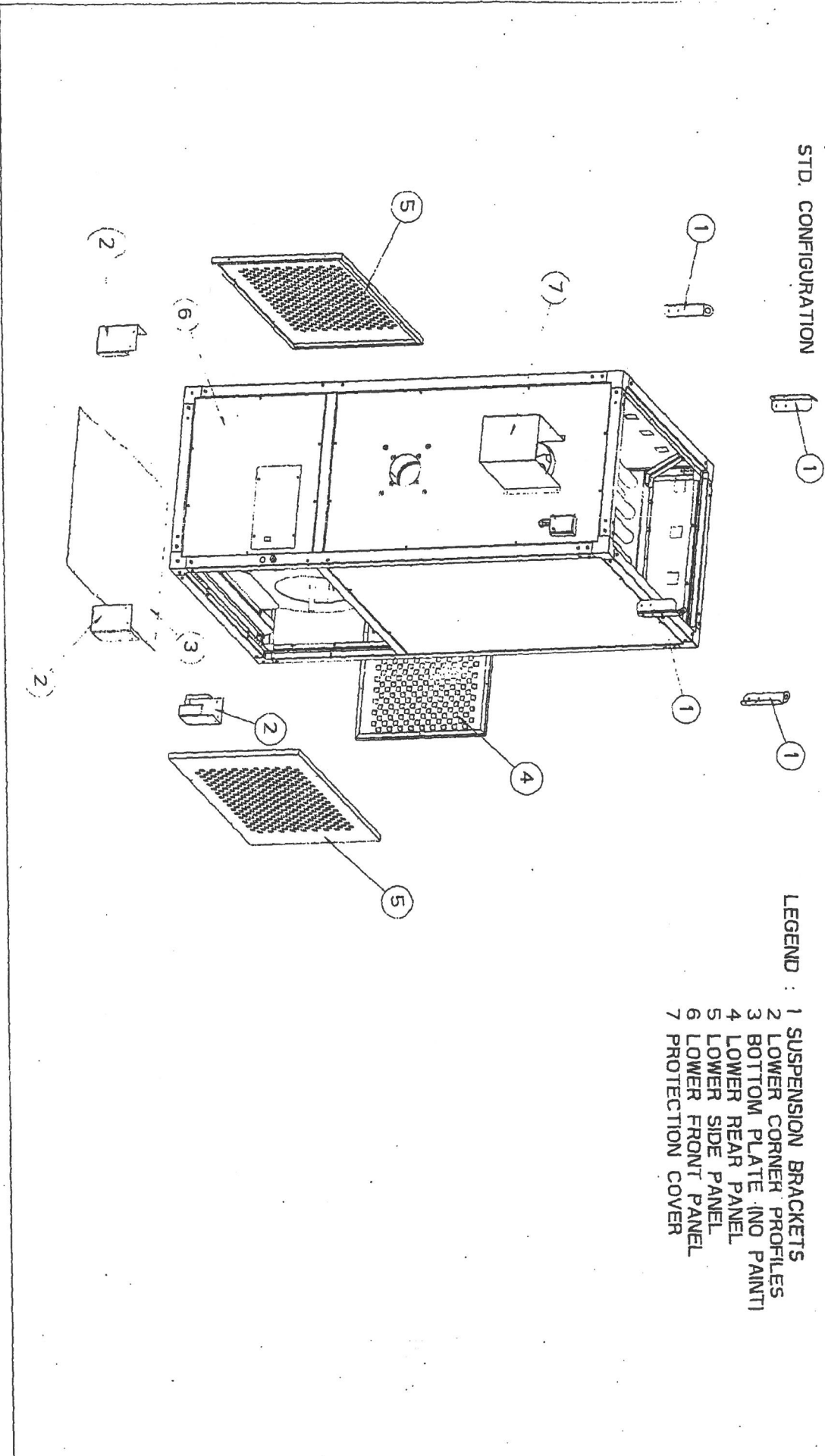
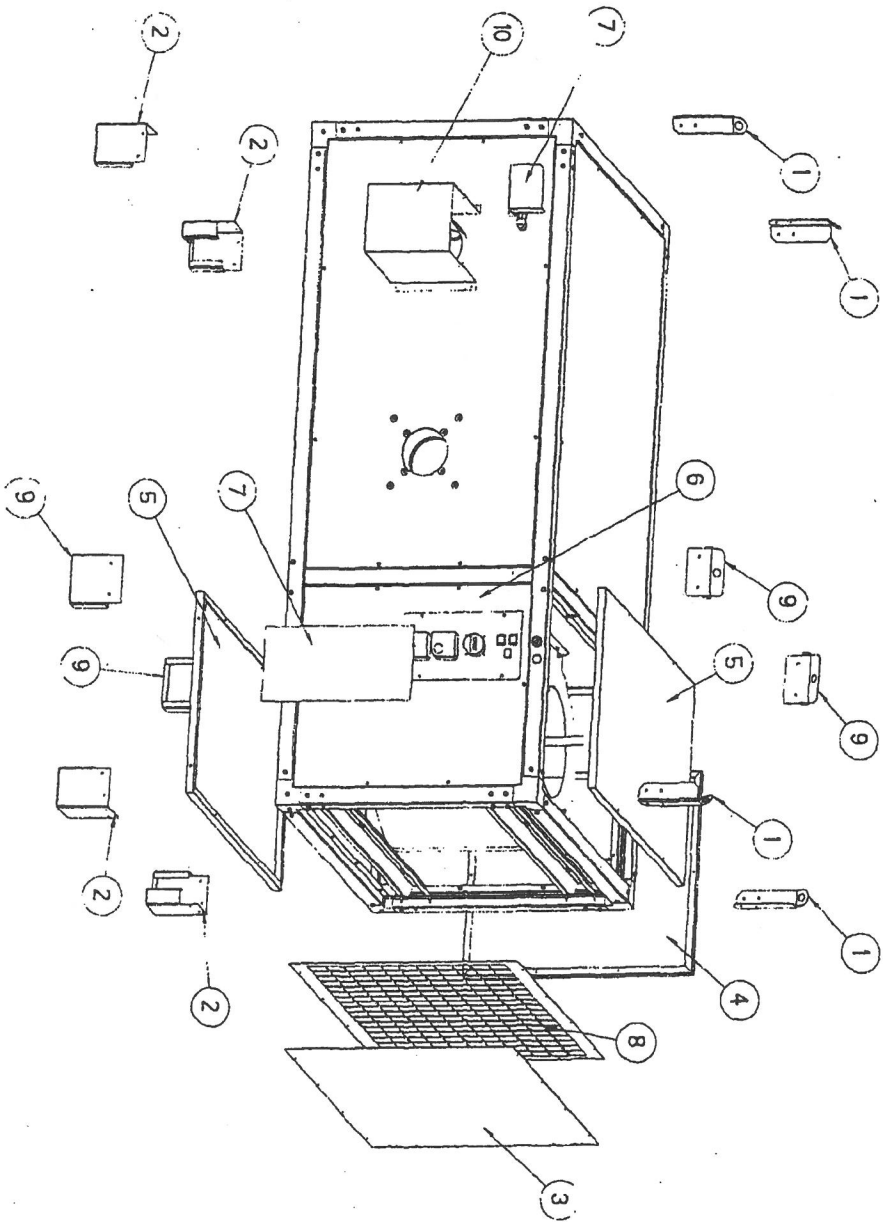

Figure 2

CONVERSION VERTICAL - HORIZONTAL : OPTIONS  
FIG 2



- LEGEND :
- 1 SUSPENSION BRACKETS
  - 2 LOWER CORNER PROFILES
  - 3 BOTTOM PLATE BLIND (PAINTED)
  - 4 LOWER REAR PANEL
  - 5 LOWER SIDE PANEL
  - 6 LOWER FRONT PANEL
  - 7 PROTECTION FRONT COVER
  - 8 BOTTOM PROTECTION PLATE (PERFORATED)
  - 9 CONVERSION KIT PARTS
  - 10 HEAT PROTECTION SHIELD