

AMBI-RAD
radiant heating systems

ASSEMBLY INSTRUCTIONS FOR MODELS : ER13/ER13HB ER22/ER22HB ER38/ER38HB

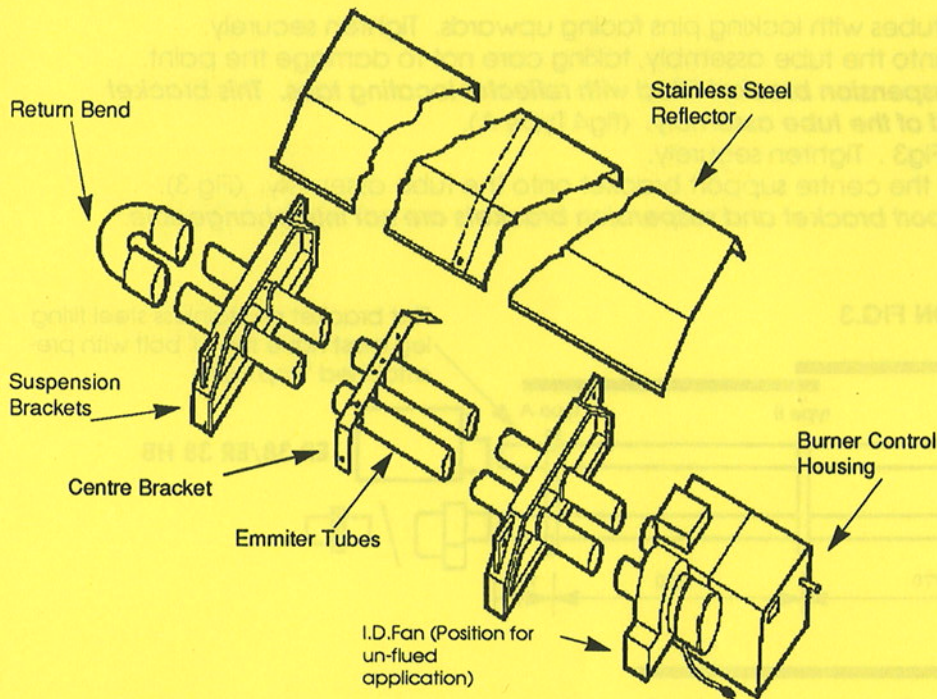
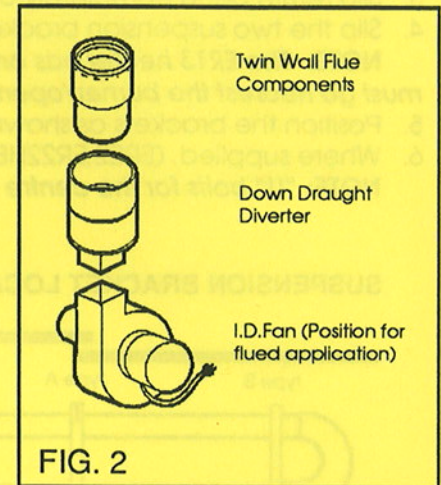

FIG. 1 Typical Arrangement of ER heater
(model ER 22)



HB Damper Assembly Replaces
I.D. Fan for Herringbone
heating systems

AMBI-RAD TECHNICAL DATA & CONTENTS

MODEL	ER13/ER13HB	ER22/ER22HB	ER38/ER38HB
Heat input	13.2kw (45,000Btu/hr)	22kw (75,100Btu/hr)	38kw(129,600 Btu/hr)
Nominal Gas Rate (Nat. Gas)	43.6 cu. ft./h. (1.26 cu. m/h.)	75 cu.ft./h. (2.12 cu.m/h.)	126 cu.ft./h. (3.6 cu.m/h.)
(Propane)	18 cu. ft./h. (0.5 cu.m/h.)	30 cu. ft./h. (0.85 cu.m/h.)	52 cu.ft./h. (1.47 cu.m/h.)
Gas Supply Connection	Rc3/8 (3/8in B.S.P. external taper)	Rc 1/2 (1/2in B.S.P. external taper)	
Electrical Supply	240v 1phase 50hz		
Internal Fuse Rating	1 A		
Current Rating	0.55A max. inductive (HB models 0.04A + main fan current)		
Ignition	Electronic Programme Start-Up with spark ignition		
Total Installed Weight	56kg (123.5lb)	92kg (206lb)	101kg (223lb)
Exhaust Flue (Optional)	100mm (4in.)dia.	125mm (5in.) dia.	125mm (5in.)dia.
Burner Assembly	1 qty.	1 qty.	1 qty.
Induced Draught Fan	ER13 only	ER22 only	ER38 only
Damper Assembly	ER13HB only	ER22HB only	ER38HB only
Return Bend	Yes	Yes	Yes
Stainless Steel Tube	No	No	1qty. 100mm dia. x 5240mm
Mild Steel Tube	2 qty. 60mm dia. x 2896mm	2 qty. 76mm dia. x 4630mm	1 qty.100mm dia. x 5240mm
Tube Brackets	1 type 'A', 1 type 'B'.	2 type 'B' and 1 Centre Bracket	2 type 'A' and 2 type 'B'
Stainless Steel Reflector	1 qty. 3048mm	2 qty. 2344mm	3 qty.1829mm
Electrical Flying Lead	1 qty.	1 qty.	1 qty.
Sundry Items	Nuts, Bolts, Washers e.t.c.		

HB ACCESSORIES

- 1 HB Type 1 Fan. Single phase standard.(Three phase available upon request).
- 1 Manifold kit to individual specification, including aluminium manifold tubing, tees, connectors, bends e.t.c.
- 1 Jointing compound gun and a quantity of silicon sealant.
- 1 Square to Round exhaust flue transition piece. (Rectangular telescopic wall flue available upon request).

ASSEMBLY INSTRUCTIONS FOR ER13/ER13HB, ER22/ER22HB

1. Support radiant tubes on blocks, trestles etc, about 175mm apart, ensuring the tube weld is facing downward.
2. Ensure tubes are clear internally.
3. Slip return bend completely onto tubes with locking pins facing upwards. Tighten securely.
4. Slip the two suspension brackets onto the tube assembly, taking care not to damage the paint.

NOTE: The ER13 heater has one suspension bracket fitted with reflector locating tabs. This bracket must go nearest the burner/open end of the tube assembly. (fig4 Type A).

5. Position the brackets as shown in Fig3 . Tighten securely.

6. Where supplied, (ER22,ER22HB), fit the centre support bracket onto the tube assembly. (Fig 3).

NOTE: "U" bolts for the centre support bracket and suspension brackets are not interchangeable.

SUSPENSION BRACKET LOCATION FIG.3

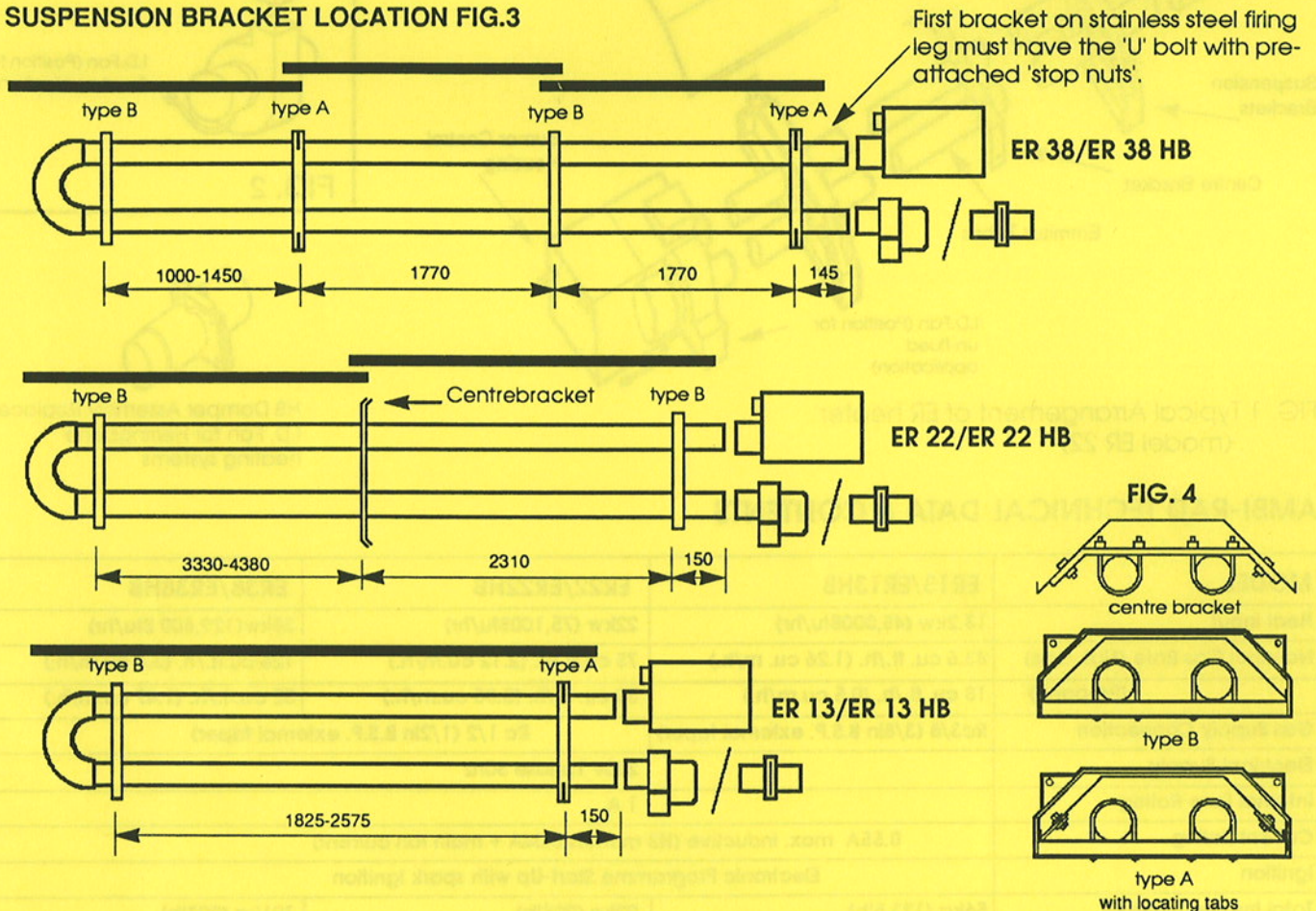

ASSEMBLY INSTRUCTIONS FOR ER38/ER38HB

1. Identify the difference between the two radiant tubes. The burner tube is labelled stainless steel and weighs less than the return tube. The stainless steel tube must go on the firing leg only. See Fig. 3.
2. Support radiant tubes on blocks, trestles etc. about 300mm apart making sure the tube weld is facing downward.

3. Ensure tubes are clear internally.

4. Slip return bend completely onto tubes with the locking pins facing upwards. Tighten securely.

5. Taking care not to damage the paint, slip the four suspension brackets onto the tube assembly. There are two types of suspension brackets: Type "A" and Type "B". Position these brackets as shown in Fig 3. **NOTE: One of the Type "A" brackets must be fitted with one standard "U" bolt and one extra long threaded "U" bolt. The extra long threaded "U" bolt with 'stop nuts' to be located on the stainless steel firing tube as indicated and clamped in position. Clearance of 3mm MUST be provided around the tube to allow for thermal expansion.**

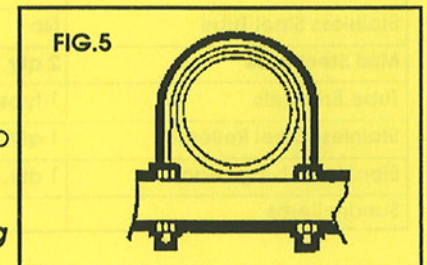

INSTALLATION

We recommend that at this stage the tube assembly is raised into position and suspended by its two end brackets only from previously fixed chains, of 4mm gauge galvanised welded link construction or fixed to two

wall mounting brackets which must incorporate a short section of hanging chain to allow movement due to thermal expansion. Alternatively 10mm diameter mild steel drop rods can be used. Wall mounting brackets must support the heater at an angle of inclination of between 35 degrees and 55 degrees and are available from the manufacturer. The angle is varied by adjusting the drop rod bolts or chain on each bracket.

NOTE: If the heater is to be wall mounted the return bend must be on the left-hand side when viewed facing the wall, with the burner fitted to the tube nearest the floor. A 90 degree bend must be fitted to the down draught diverter to discharge products of combustion horizontally away from the heater.

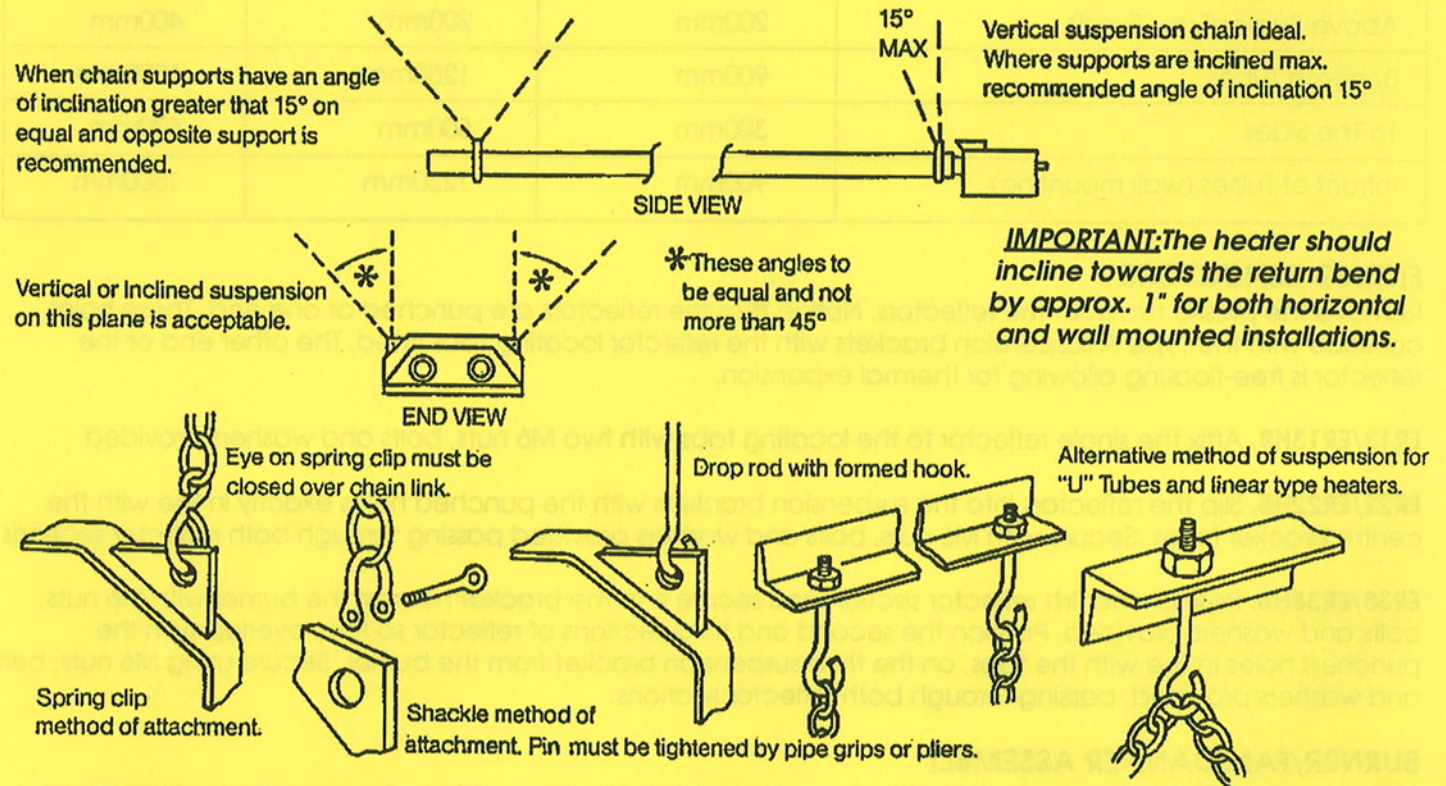

Attachment to the heater bracket support lugs should be made by either a spring hook, "D" shackle, nut bolt and large washers, or in the case of drop rods, a formed hook and due allowance must be made for thermal expansion of the heater.

The hanging attachments to overhead steelwork etc. must be purpose made to good sound engineering practice or of a proprietary type fixing. They must be adequately fixed and designed to carry the whole weight of the heater and to permit free movement due to linear expansion.

In the event of suitable roof steelwork not being available, additional steelwork should be fitted to enable vertical hangers to be used for suspending the heaters. If there is any doubts as to the strength or suitability of roof steelwork to which heaters are to be suspended, please refer to consultant/architect/Client owner of the building.

Recommended minimum and preferred mounting heights for the AMBI-RAD heaters are as follows:

MODEL		ER13/HB	ER22/HB	ER38/HB
Minimum Mounting Height	Horizontal	3.0m	3.6m	4.3m
	Wall Mounted	2.7m	3.0m	3.6m
Preferred Mounting Height	Horizontal	3.6m-6.0m (4.5m*)	4.2m-14m (7.0m*)	4.9m-25m (11m*)
	Wall Mounted	3.0m-4.0m	3.5m-5.5m	4.0m-7.0m

*HEIGHTS OVER THESE FIGURES CONTACT AMBI RAD DESIGN OFFICE.

The proposed position of the heater should be selected so that the clearance distances to combustible materials will be ensured. These are tabulated overleaf.

MINIMUM CLEARANCE DISTANCES

Model	ER13/ER13HB	ER22/ER22HB	ER38/ER38HB
Above Reflector	100mm	100mm	100mm
Above Burner/Fan (unflued)	300mm	400mm	400mm
Above Burner/Fan (flued)	200mm	200mm	400mm
Beneath Tubes	900mm	1250mm	1500mm
To The Sides	300mm	500mm	500mm
Infront of Tubes (wall mounting)	900mm	1250mm	1500mm

FITTING REFLECTORS

Remove the plastic film from the reflectors. Notice that the reflectors are punched at one end. These holes coincide with the Type A suspension brackets with the reflector locating tabs fitted. The other end of the reflector is free-floating allowing for thermal expansion.

ER13/ER13HB. Affix the single reflector to the locating tabs with two M6 nuts, bolts and washers provided

ER22/ER22HB. Slip the reflectors into the suspension brackets with the punched holes exactly in line with the centre bracket holes. Secure with M6 nuts, bolts and washers provided passing through both reflector sections.

ER38/ER38HB. Position the first reflector section and secure it to the bracket nearest the burner with M6 nuts, bolts and washers provided. Position the second and third sections of reflector so they overlap with the punched holes in line with the tabs, on the third suspension bracket from the burner. Secure using M6 nuts, bolts and washers provided, passing through both reflector sections.

BURNER/FAN/DAMPER ASSEMBLY

Slide the burner control assembly onto the right hand tube (when viewed from the open ends of the tubes) ensuring it is fully engaged and whilst holding assembly horizontal secure with pinch screws provided.

Slide the fan/damper assembly onto the left hand tube ensuring it is fully engaged. **The fan discharge outlet should face vertically upwards, if heater is to be individually flued or horizontally away from burner if unflued.** Insert 3 pin fan connection plug into the socket of the burner housing. **Where the damper assembly is fitted the damper blade must be in the vertical plane.** Secure with pinch screw.

FLUE CONNECTION (ER13, ER22, ER38)

The Ambi-Rad heater may be installed with or without a flue to atmosphere providing the air supply and building ventilation requirements as stated in BS 6896:1991 are complied with.

If the heater is installed without a flue, ensure that combustion gases do not impinge on combustible materials. The maximum permitted temperature for such materials is 65 degrees (BS. 3561). Due consideration must be given to the possibilities of condensation forming on cold surfaces.

If the heater is to be installed with a flue a downdraught diverter (supplied as an optional extra) must be fitted to the induced draught fan exit by means of the screws and clamps provided.

The flue construction should be adequately supported at regular intervals from the building structure and terminated externally with a British Gas Tested and Certified terminal. The maximum flue length is 9m (30ft) and maximum number of bends is two. All connections in the flue pipe must be properly sealed with heat resistant caulking and faced off with fire cement.

FOR GAS CONNECTION, COMMISSIONING, ELECTRICAL DETAILS AND SERVICING SEE PUBLICATION USER INSTALLATION AND SERVICING MANUAL.



Ambi-Rad Limited, P.O. Box 30, Enfield Works,
Mucklow Hill, Halesowen, West Midlands. B62 8DS
Tel: 021-503-0707 Fax: 021-501-2955