

## FLOOR STANDING WARM AIR HEATER Comet+ (Gas & Oil)



### INSTALLATION / COMMISSIONING / SERVICE / USER MANUAL

Supply of Machinery (Safety) Regulations 2008  
Supply of Machinery (Safety) Regulations (A) 2011  
Electrical Equipment (Safety) Regulations 2016  
Electromagnetic Compatibility Regulations 2016  
Gas Appliances (Product Safety and Metrology etc (Amendment etc)  
(EU Exit) Regulations 2019)

Please read this document carefully before commencing installation, commissioning and/or servicing.  
Leave it with the end user/site agent to be placed in their premises technical file after installation.

#### WARNING

Improper installation, adjustment, alteration, service or maintenance can cause property damage, injury or death.  
All work must be carried out by appropriately qualified persons.

The manufacturer does not take any responsibility in the event of non-observance of the regulations concerning the connection of the apparatus causing a dangerous operation possibly resulting in damage to the apparatus and/or environment in which the unit is installed.



# CONTENTS

## Contents

---

### Product Introduction

---

Comet+ Range .....	4
--------------------	---

### Health and Safety

---

General Health and Safety .....	5
Before Using this Appliance .....	6
Location/Positioning .....	6
General Requirements.....	7
Electrical Supply.....	8

### General

---

General.....	9
Disposal Instructions .....	10
Installers Responsibilities .....	11
Compliance Notices .....	11
Warranty .....	12

### Technical Data (TD)

---

Technical data .....	14
Dimensions.....	16

### Installation

---

Pre Installation .....	18
Handling.....	18
Installation Considerations .....	19
Clearances and Access.....	20
Combustion Air/Ventilation Requirements.....	20
Flue System.....	20
Gas Installation and Connection.....	25
Oil Installation/Connection .....	25
Ducted Models .....	28
Nozzled Models .....	29
Condensate Drains.....	29
Electrical Installation/Connection.....	29
Controls.....	31

### Commissioning

---

Commissioning .....	32
Unit Operation.....	34
Overheat Protection .....	34

### Maintenance

---

To Clean the Heat Exchanger .....	36
Burner Removal .....	36
Burner Maintenance .....	36
Heat Exchanger Maintenance.....	37
Routine Maintenance.....	37
Fan Assembly.....	37
Gas/Oil Control Valve Maintenance .....	37
Cleaning of Heater.....	37

### Removal and Replacement of Parts

---

Multi-Block Gas Valve .....	38
Fan and Limit Stat .....	38
Burner Replacement .....	38
Recommended Tools.....	38

### Spare Parts

---

Spare Parts.....	39
------------------	----

### Trouble Shooting

---

Fault finding .....	40
---------------------	----

### User Instructions

---

User Instructions .....	41
-------------------------	----

# PRODUCT INTRODUCTION

COMET+ is the latest generation of floor standing cabinet heaters, combining innovative design with proven heat exchanger technology to provide a highly efficient, cost effective and durable range. The heaters are CE and UKCA certified and compliant with BS EN 17082 for use in non domestic installations.

The COMET+ range encompasses heating duties from 45kW to 300kW in a number of variants:-

- Natural gas (G20) fired;
- Natural gas (G20) fired high efficiency condensing;
- Propane gas (G31) fired;
- Oil (Class D 35 second gas oil) fired complete with a fire valve and oil filter supplied as loose components;
- Kerosene (Class C2 28 second heating oil) fired complete with a fire valve and oil filter supplied as loose components;
- Free blowing with rotating long throw discharge nozzles complete with horizontal louvres (supplied loose);
- Ducted discharge with top outlet suitable for duct connection.

The following options are available upon request:-

- Front flue connection (rear connection as standard)
- External weatherproof casing
- Right hand side grille (left hand side as standard)
- Flat pack format to aid with installation in areas with restricted access.

All models have been designed for internal use only unless specifically designated for external use (optional external weatherproof casing).

The type of fuel, the input rate and the electrical supply requirement is shown on the heater rating plate. Check the rating plate to determine if the heater is appropriate for the intended installation. **It is especially important to check that the fuel type shown on the data plate corresponds with the fuel intended to be used/available on site.** All available variants are listed in the technical data section following on pages 14 and 15.

This installation manual is shipped with the unit. Verify that the literature is correct for the model being installed. If the manual is incorrect for the heater, contact the supplier before beginning installation. The instructions in this manual apply only to the models listed.

This installation manual must be read in conjunction with the burner installation manual shipped with the unit. Verify that the manual is correct for the burner installed in the heater. If the manual is incorrect for the burner, contact the supplier before beginning installation.

All heaters are factory tested prior to despatch. Each heater is individual. The relevant data can be found on the data plate attached to the heater.

Installation should be carried out by a suitably qualified installer in accordance with these instructions and the current rules and regulations in force. The installer is responsible for the safe installation of the heater.

# HEALTH AND SAFETY

## General Health and Safety



### WARNING

Warning is used when failure to heed or implement the instruction(s) can lead to not only component damage, but also to a hazardous situation being created where there is a risk of personal injury.



### CAUTION

Caution is used when failure to follow or implement the instruction(s) can lead to premature failure or damage to the heater or its component parts

## GAS LEAK EMERGENCY

If you can smell gas from or near the heater:

- Do not try to light any appliance
- Do not smoke or light matches
- Do not turn electrical switches on or off
- Open doors and windows, to air the room
- Close the fuel control to the device
- If you still smell gas turn off the supply at the meter unless the meter is in the cellar
- Raise the alarm and evacuate all personnel to a safe place
- Promptly Call your Gas Emergency number

Enter your gas emergency number below

- Do not store or use petrol or other flammable vapours and liquids in the vicinity of the appliance.
- In case of persistent problems, contact your distributor.

Improper installation, adjustment, alteration, service, or maintenance can cause property damage, injury, or death.

Read the installation, operation, and maintenance instructions thoroughly before installing or servicing this equipment.

Do not use this appliance if any part has been immersed in water. Immediately call a qualified service technician to inspect the appliance and replace any gas control that has been immersed in water.

Gas-fired appliances are not designed for use in hazardous atmospheres containing flammable vapours or combustible dust, in atmospheres containing chlorinated or halogenated hydrocarbons or in applications with airborne silicone substances.

Should overheating occur, or the gas supply fail to shut off, isolate the manual gas valve to the appliance before shutting off the electrical supply.

This appliance is not intended for use by persons (including children) with reduced sensory or mental capabilities or lack of experience and knowledge, unless they have been given supervision or instruction concerning use of the appliance by a person responsible for their safety.

Children should be supervised to ensure that they do not play with the appliance.

Carry out a risk assessment for the task to be carried out and ensure the correct use of any Personal Protective Equipment.

This manual should be kept in a safe place for future reference.

## Before using this appliance:

- Carefully read these instructions and follow the processes explained by the manufacturer. These instructions are only valid for appliances designed to operate in Europe.
- Check that the voltage indicated on the type plate corresponds to the mains supply voltage. If the country code and gas category on the appliance data label does not match the country of installation or the country codes and gas categories as shown in this instruction manual, it will be necessary to contact the distributor or manufacturer to provide the necessary information for the modification of the appliance to the conditions of use for the country of installation
- Ensure that the heater has been securely fastened in its final mounting position.
- Installing, commissioning, testing, programming and maintenance of these products must only be carried out by suitably qualified and trained technicians and in full compliance with all applicable regulations and current best practices.
- Check if the appliance as described on the packaging label is in accordance with the correct type and model as specified on the data plate and complies with your customer order.
- Check that the temperature ranges given and those of the location match. The appliance must be powered with a voltage corresponding to the value shown on the rating plate.
- The heater must be installed in accordance with the rules in force and local regulations/legislation as appropriate plus all local building codes.
- Ensure that the burner manual is available.

- Installers should satisfy themselves that the gas or oil pipework installation is carried out in accordance with all current legislation, Codes of Practice and recommendations.

## Location/Positioning



**The oil variants of the heaters must be installed in accordance with the current OFTEC regulations for oil fired products.**

**Under no circumstances should any item be placed on or above any part of the heater, whether it is being used or not.**

**All basic criteria must be satisfied prior to commencing the installation and commissioning process.**

**The heater must be positioned and installed to comply with all relevant standards and guidelines.**

**The heater installation should meet the local and national fire regulations and insurance criteria; this is critical if the heater is to be installed within a special risk area (e.g. being within close proximity to where petrol engined vehicles are stored or parked, where cellulose spraying takes place, where woodworking machinery is being operated, etc.).**



**The heater must not be installed within an area with unsuitable conditions, e.g. where the atmosphere is highly corrosive, has a high degree of salinity, or where high wind velocities may affect burner operation.**

**Suitable protection should be provided for the appliance when it is to be located in a position where it may be susceptible to external mechanical damage; for example, fork lift trucks, overhead cranes etc.**

Heaters must not be located in hazardous areas, however, it is permissible for the heater to supply air to such areas.

The heater must not be installed within an environment where there is a high concentration of chlorides, fluorides, salts, or other aggressive or volatile chemicals/ compounds. Nor should the heater be positioned where the burner could be adversely affected by high winds or draughts.

The location chosen for the heater must allow for the fitting of an effective flue system.

The location must also allow for adequate clearance for the air supply, return air circulation, gas supply and electrical supply, whilst also providing good and safe working access.

The heater must be installed on a flat and level surface made from non-combustible material, which is sufficiently robust to withstand the weight of the heater and any ancillary equipment.

## General requirements



**Unauthorised modification of the appliance, or departure from the manufacturers guidance on intended use and recommended practices may constitute a hazard. To ignore the warning and caution notices, and advice from the manufacturer on installation, commissioning, servicing, or use, will jeopardise any applicable warranty.**

**Moreover, such a situation could also compromise the safe and efficient running of the appliance itself and thereby constitute a hazard.**

**All heaters must be earthed.**

The installation of the appliance must meet all the relevant national, regional and local criteria.

## Prior to installation the following points should be considered:-

- The position of the heater for the optimum efficient distribution and circulation of warm air.
- The position of the heater relative to the route of the flue.
- The position of the heater relative to the supply of fuel.
- The position of the heater relative to the electrical services, and if appropriate, any additional controls.
- The position of the heater relative to the supply of fresh combustion air.
- The height if applicable at which the heater is to be mounted and potential stratification/circulation problems.
- The position of the heater relative to service and maintenance requirements.

The heater output should be sized to suit the area that it is heating; heat loss calculations must be carried out to ensure the correct sized heater is installed. The Reznor technical department can provide guidance.

The appliance is designed to work in a maximum ambient temperature of 40°C.

The air heaters are designed for mounting directly on the floor and do not need any fixing.

## Electrical supply



**Ensure the supply is in accordance with the manufacturer's recommendations and is as stated on the appliance data plate.**

**The main electrical supply must not be switched off or disconnected as a method for stopping the heater; the exception to this is in an emergency, or during servicing, where the heat exchanger has been given sufficient cooling time to prevent damage from occurring. Claims for damage will not be considered if they result from incorrect wiring or incorrect use of the heater.**

Wiring external to the heater must be installed in accordance with all local, regional and national regulations.

The means of connection to the main electrical supply must allow for complete electrical isolation of the heater and furthermore, the supply should only be used to serve the heater itself and no other plant or equipment.

The position of the isolation switch must be such that it is adjacent to the heater and easily accessible at all times. In addition, the isolator itself must have a contact separation of not less than 3mm.

The control fuse ratings are detailed on the appliance data plate.



**Ensure that the electric and gas or oil supplies are turned off before any electrical work is carried out on the heater.**

Ensure that wiring cannot make contact with any surfaces liable to be subject to high temperatures or where the insulation of the wiring could be impaired as a result of such contact.



## General

This manual and the burner manual are integral parts of the heater, therefore they should always be carefully kept and should always be provided together with the heater, if it is transferred to another owner or user. If this manual or the burner manual is damaged or lost, a new one should be requested from the installer or from the manufacturer.

After unpacking the product, please check the contents to ensure all components are present. If not, please contact your supplier.

Before installation, carefully read these instructions and follow the processes explained by the manufacturer. These instructions are only valid for appliances designed to operate in Europe. If the country code and gas category on the appliance data label does not match the country of installation or the country codes and gas categories as shown in this instruction manual, it will be necessary to contact the distributor or manufacturer to provide the necessary information for the modification of the appliance to the conditions of use for the country of installation.

Installing, commissioning, testing, programming and maintenance of these products must only be carried out by suitably qualified and trained technicians and in full compliance with all applicable regulations and current best practices.

The installation must be carried out by suitably qualified personnel who, at the end of the work, will commission the appliance and issue to the owner a copy of the commissioning report, which also confirms that the installation has been carried out in accordance with regulations & standards applicable to the country of use and in accordance with the manufacturers instructions.

This appliance has been manufactured specifically for room heating and must be used only for this purpose. Contractual liability of the manufacturer in respect of damages caused to people, animal or premises by incorrect installation, settings, maintenance or by improper use of the heater is excluded.

Check if the appliance as described on the packaging label is in accordance with the correct type and model as specified on the data plate and complies with your customer order.

Check that the temperature ranges given and those of the location match. The appliance must be powered with a voltage corresponding to the value shown on the rating plate.

The unit must be installed in accordance with the rules in force and local regulations/legislation as appropriate plus all local building codes. Installers should satisfy themselves that the gas or oil pipework installation is carried out in accordance with all current legislation, Codes of Practice and recommendations.

Additionally it may be necessary to protect the gas valves which form part of the heater or burner assembly from potential pipe contamination particularly, but not exclusively, where copper gas pipework is used.



**If the appliance is to remain unused for long periods, it is recommended that the following operations are carried out:**

- **Turn the appliances' electrical supply off via the local isolator.**
- **Close the main fuel supply valve.**

If there is a long period of time between operation of the heater, it is recommended that you contact your installer to carry out the new start-up.

The heater must be fitted with approved accessories and spares only. The manufacturer is not liable for damages arising from the improper use of the heater or from the use of non-original materials or accessories. References to Laws, Regulations, Directives and Technical Rules mentioned in this manual are provided only for information purposes and are in force when the manual is printed.

The introduction of new provisions or amendments to current laws does not represent an obligation of the manufacturer towards third parties.

Repairs or maintenance are to be performed by suitably trained and qualified personnel only.

Do not modify or tamper with the appliance - the manufacturer will not be held responsible for any third party modifications made to the heater.

The services that are to be connected (fuel pipes, power supply, etc.) must be suitably secured and must not be hazardous or present the risk of a trip hazard.

The manufacturer is responsible for the product compliance with Laws, Directives or Construction Rules in force when the product is marketed. The knowledge and observance of the laws and standards regarding plant design, installation, operation and maintenance are the sole responsibility of the designer, installer and user. The manufacturer shall not be held responsible for failure to comply with the instructions of this manual, for the consequences of any operations carried out and not specifically provided for or for translations open to misinterpretation.

The electrical system must feature suitable individual and independent electrical protection for each appliance which, in case of accidental failure, will be activated on the single appliance without prejudice to the proper operation of the other units present on the installation.

**Note:**

The appliance is designed to be operated with the heating capacity and the air flow rate specified in the technical data section following. If the heating capacity is too low and/or the air flow rate is too high, combustion products may condense, resulting in the irreparable corrosion of the heat exchanger. If the heating capacity is too high and/or the air flow rate is too low, overheating of the heat exchanger may occur, resulting in the activation of the high temperature safety devices and could cause damage to the exchanger.

**Disposal instructions**

Disposing of the appliance must be carried out by an authorised company and in compliance with the applicable laws. Before taking waste to Authorised Collection Centres, dismantle and separate the various materials that comprise it. In summary these are:

- Ferrous materials
- Aluminium and copper
- Electrical wiring
- Seals and insulating materials
- Plastic materials
- Electronic cards

## Installers responsibilities

---

It is the installers responsibility to:-

- Install the heater, as well as the gas or oil, condensate drainage (where applicable) and electrical supplies, in accordance with all applicable specifications and codes. The manufacturer recommends the installer contact a local Building Inspector, Fire Officer or Insurance Company for guidance.
- Use the information given in this manual together with the local and national codes to perform the installation.
- Install the heater in accordance with the clearances given on page 20.
- Plan for the installation of suitably designed supports, flues and air intakes.
- Provide access clearance to the unit and burners for servicing.
- Provide the owner with a copy of this installation, commissioning, operation and service manual.
- Provide a copy of the commissioning report for the heater.
- Provide a copy of the burner manual.
- Ensure that there is sufficient ventilation in the area to comply with the requirements of the heater and all relevant local and national codes.



**Ignoring the warning and caution notices and the advice from the manufacturer on installation, commissioning, servicing or use, will jeopardise any applicable warranty. This could also compromise the safe and efficient running of the appliance itself and thereby constitute a hazard.**

## Compliance notices

---

The heater range detailed herewith is manufactured within a strictly controlled quality environment to the parameters of ISO 9001.

These instructions are only valid if the following country code is on the appliance GB. IE. If this code is not present on the appliance, it is necessary to refer to the technical instructions which will provide the necessary information concerning the modification of the appliance to the conditions of use for the country.

The manufacturer has taken reasonable and practical steps to ensure that all heaters are safe and without risk when properly used. These heaters should therefore only be used in the manner and purpose for which they were intended, and in accordance with the recommendations detailed herewith. The manufacturer supports all new products being supplied to their customers with a comprehensive information pack; this clearly defines mandatory instructions for the safe installation, use, and maintenance, of the appliance(s).

Where proprietary items are incorporated into any of the heaters, detailed information and instructions are also provided as part of the information pack. It is the responsibility of the installer, owner, user, or hirer of the heater to ensure that they are familiar with the appropriate information/manuals supplied by the manufacturer and the safety instructions. In addition, operators must be suitably trained in the use of the appliance so as to ensure its continued safe and efficient use.

The manufacturer has a commitment to continuous improvement and therefore reserves the right to amend or change the specification of the heater subject to compliance with the appropriate national, regional and local regulations.

## The Comet+ Air Heater range conforms to the following standards:

### **BS EN 292-1**

Safety of Machinery - Basic Concepts, General Principles for Design Basic Terminology Methodology

### **BS EN 292-2**

Safety of Machinery - Basic Concepts, General Principles for Design Technical Principles and Specifications

### **BS EN 60204-1**

Safety of Machinery - Electrical Equipment for Machines Specification for General Requirements

### **BS EN 60335-1**

Safety of Household and Similar Electrical Appliances General Requirements

### **BS EN 60335-2**

Safety of Household and Similar Electrical Appliances. Particular requirements for gas, oil and solid-fuel burning appliances having electrical connections

### **BS EN 55014**

Limits and methods of measurement of radio disturbance characteristics of electrical motor-operated and thermal appliances for household and similar purposes, electrical tools and similar electric apparatus

### **BS EN 17082**

Non-domestic forced convection gas-fired air heaters.

The heater range also complies with the following:-

- Supply of Machinery (Safety) Regulations 2008 and Supply of Machinery (Safety) Regulations (A) 2011
- Electrical Equipment (Safety) Regulations 2016
- Electromagnetic Compatibility Regulations 2016
- Gas Appliances (Product Safety and Metrology etc (Amendment etc) (EU Exit) Regulations 2019)

## Warranty

---

The heater is supplied with a 1 year parts and labour warranty and a further year on all parts excluding consumables.

The warranty commences from the date of dispatch from the manufacturer, and is subject to the terms detailed within the Manufacturers 'conditions of business' unless otherwise agreed at the time of order.

### **Note: The warranty may be invalidated if:**

- The installation is not in accordance with these instructions.
- The heater has been installed without proper clearances wherever clearances are required.
- The flue arrangement and ventilation/ combustion air supply for the heater are not in accordance with the manufacturers recommendations, and local and national codes of practice and similar standards.
- Air flow through the heater is not in accordance with the manufacturers technical specifications.
- Internal wiring on the heater has been tampered with or unauthorised service or repairs undertaken.
- The main electrical supply input to the heater has been interrupted during the heating mode.
- The heater has been subject to and affected by the ingress of water in any form.
- The heater is not operated at the rating(s) laid down in the manufacturers technical specifications.
- The heater has not been operated or used within the normal scope of its intended application.

- The air delivery system is modified in any way.
- The manufacturer's recommended minimum service and maintenance requirements have not been complied with.

**Note: All warranty claims must contain the following information to enable processing to take place.-**

- Heater model
- Heater serial number
- Order reference/date of order, together with:-
- Full installation details (name and address)
- Details or symptoms of fault
- Installers name and address
- Commissioning and service records

Faulty parts must be returned to the supplier, the address of which is provided at the rear of this manual. Any such parts will undergo inspection to verify the claim. Replacement parts supplied prior to this may be charged, and a credit supplied upon subsequent validation of the warranty claim. Consumable items are specifically not included within the scope of the warranty.

**Note: Notification is required immediately a fault is suspected.**

The manufacturer will not accept responsibility for any additional damage that has been caused, expense incurred, or consequential loss resulting from any failure of the heater(s).



**The electrical isolator should only be used for maintenance purposes or in an emergency. It should not be used for closing down the main burner as it switches off the fan prematurely and may damage the heat exchanger, invalidating the warranty.**

# TECHNICAL DATA

COMET+ heaters are available in natural gas, natural gas condensing, propane, oil fired and kerosene variants with nozzles or a ducted outlet. The product codes are as shown below.

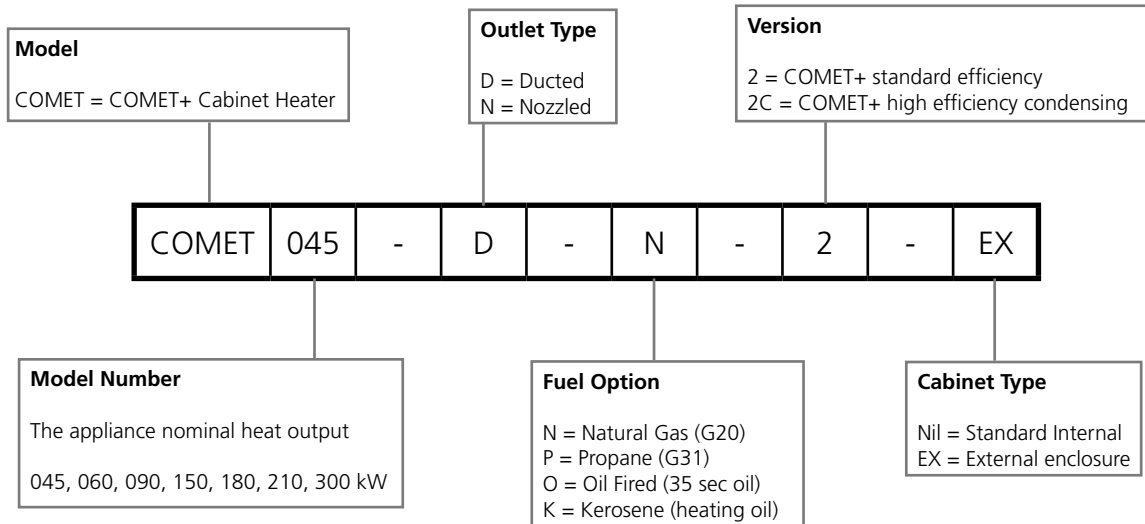

Note:

Heaters with a standard internal cabinet are suitable for internal use only.  
 Heaters with an external enclosure (EX) are suitable for external or internal use.  
 Kerosene variants are only available up to model 150

<b>Technical Data</b>							
<b>COMET+</b>	<b>045</b>	<b>060</b>	<b>090</b>	<b>150</b>	<b>180</b>	<b>210</b>	<b>300</b>
<b>Heating Data</b>							
Nominal Heat Output (kW)	45	60	90	150	180	210	300
Heat Input (kW)	48	64	96	160	193	225	321
Temperature Rise (°C)	41	41	41	41	41	41	41
Thermal Efficiencies (Nett CV %)	Minimum 93.5%						
Nox Seasonal (mg/kW)	45.0	45.0	45.0	45.0	45.0	45.0	45.0
<b>Gas Fired</b>							
Gas Consumption Natural Gas (G20) (m <sup>3</sup> /hr)	4.50	6.00	9.00	14.99	17.99	20.99	29.99
Gas Consumption Propane Gas (G31) (m <sup>3</sup> /hr)	1.86	2.48	3.72	6.20	7.44	8.67	12.39
Minimum Dynamic Inlet Pressure Nat Gas (G20) (mbar)	17.5	17.5	17.5	17.5	17.5	17.5	17.5
Minimum Dynamic Inlet Pressure Propane (G31) (mbar)	37	37	37	37	37	37	37
Gas Connection (Rc)	¾"	¾"	¾"	¾"	1¼"	1¼"	1½"
<b>Oil Fired</b>							
Oil Consumption (Class D 35 sec gas oil) (kg/hr)	4.44	5.91	8.87	14.79	17.74	20.70	29.57
Oil Consumption (Class C2 28 sec kerosene) (kg/hr)	3.74	4.99	7.48	12.47	N/A	N/A	N/A
Oil Connection (Rc)	⅜"	⅜"	⅜"	⅜"	⅜"	⅜"	⅜"
<b>Air Handling Data</b>							
Airflow (m <sup>3</sup> /hr)	3276	4392	6552	10944	13104	15264	21816
Airflow (m <sup>3</sup> /sec)	0.91	1.22	1.82	3.04	3.64	4.24	6.06
Number of Nozzles	4	4	4	4	4	4	4
Nozzle Throw (m)	26	26	29	38	44	46	48
External Static Pressure (Ducted) (Pa)	250	250	250	250	250	250	250
Fan (kW)	0.65	0.80	1.20	2.50	3.00	3.50	7.50
Full Load Current (A)	1.2	2.3	3.9	4.5	4.8	5.5	11.5
<b>General Data</b>							
Electrical Supply	415 V / 3 Ph / 50 Hz						
Nominal Flue Diameter (mm)	130	130	130	130	200	250	250
Noise Level @ 5m dB(A)	58	62	72	75	76	77	79
Net Weight (kg)	338	343	354	458	497	543	598

Natural Gas @ 38.52 MJ/m<sup>3</sup> | Propane @ 93.2 MJ/m<sup>3</sup> | Oil @ 39.06 MJ/l | Kerosene 43.10 MJ/kg

# DIMENSIONS

Dimension (mm)	Model						
	45	60	90	150	180	210	300
A - Unit Width	800	800	800	800	950	950	1100
B - Unit Depth	950	950	950	1200	1400	1400	1520
C - Unit Height	2000	2000	2000	2000	2250	2250	2250
D - Flue Diameter	130	130	130	130	200	250	250
E - Intake Duct	650	650	650	650	650	650	650
F - Intake Duct	850	850	850	1100	1300	1300	1420
G - Flue Centre	375	375	375	375	475	475	575
H - Flue Height	1777	1777	1777	1777	1970	1970	1970
K - Burner Centre	375	375	375	375	475	475	575
L - Burner Height	1176	1176	1176	1176	1250	1250	1250
M - Burner Protrusion	230	230	230	230	560	560	560
N - Ext Nozzle Height	798	798	798	798	949	949	949
P - Nozzle Height	409	409	409	409	547	547	547
Q - Duct Outlet	850	850	850	1100	1300	1300	1420
R - Duct Outlet	700	700	700	700	850	850	1000
S - Condensate Size (if fitted)	¾"	¾"	¾"	¾"	1"	1"	1"

Note:

Condensate connections are provided at high efficiency condensing versions of the heater only



**Models with nozzled outlet**

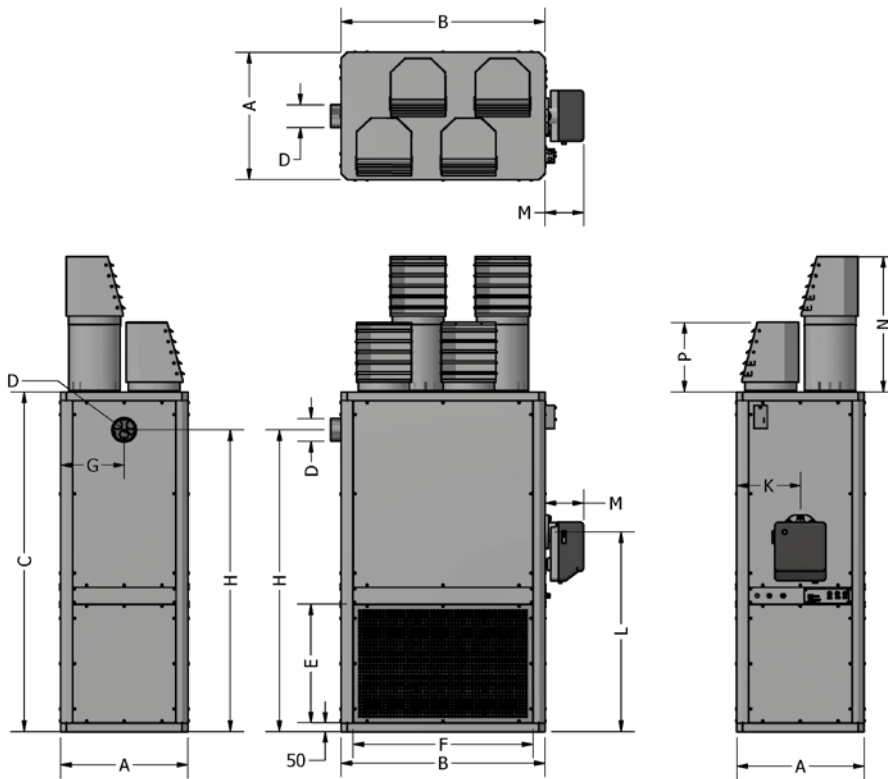

**Models with ducted outlet**

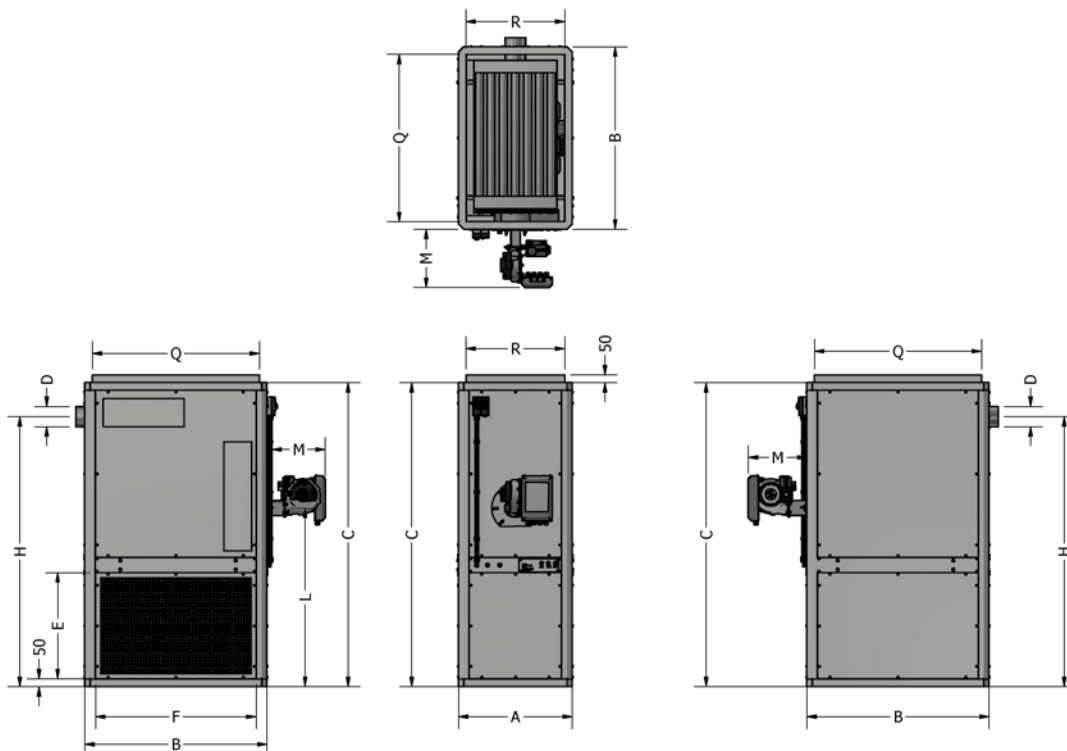

# INSTALLATION

## Pre installation

### Uncrating and Preparation

Prior to crating and shipping, this unit was test operated and inspected at the factory and left in full operating condition. If the unit has incurred damage in shipment, document the damage with the transport company and contact your supplier.

The heater will usually be supplied mounted on a pallet and wrapped in heavy gauge polythene. Nozzle heads will be supplied separately. Oil fired heaters will have the associated oil filter and fire valve separately supplied.

After unpacking the appliance leave it fastened to the pallet until just before siting to prevent damage to the unit.

Read this booklet and become familiar with the installation requirements of your unit.

Check if the local distribution conditions of electricity supply, type of gas or oil and pressure of the appliance are compatible with the data plate.

The appliance must be installed in accordance with the current rules in force and any local or national regulations.

The requirements of the "Local Building Standards office", the premises "Insurance" undertaking and the "Fire Office" must also be observed.

Before commencing installation, ensure all necessary supplies, tools and manpower are available.

Prior to installation, the assembly of the heater should be completed, it is advisable that this is undertaken in the area where the heater is scheduled to be sited.



**It is strongly advised that when positioning the heater the lifting eyes are used, thereby reducing the risk of inadvertent damage being occasioned to the heater.**

## Handling

Handling must only be carried out by a qualified engineer. If a fork-lift is used, fork the appliance using the appropriate ways in the wood pallet. Use forklift forks with a minimum length equal to the width of the machine.

Shipping and handling must be carried out with extreme care to avoid damage to the unit and danger to the persons involved.

During transportation and handling, it is forbidden to stand near the unit.

If belts or ropes are used, a rocker arm (not included) must be used to prevent the pressure exerted by the same from damaging the structure of the unit.

If the heater needs to be moved by hand, make sure that there is enough workforce available in proportion with the weight indicated in the Technical Data table on page 15 and depending on the distance to be covered.

Suitable personal protective equipment (PPE) including safety boots, gloves and eye protection must be worn for all uncrating, preparation and handling activity.

## Installation considerations

The installation location must be determined by the system designer and/or by a competent person able to take into account technical requirements and the standards and regulations in force.

Generally, special permissions need to be obtained (e.g. regulations concerning zoning, architecture, fire safety, environmental pollution, noise emission, etc.).



**Under no circumstances should any item be placed on or above any part of the heater, whether it is being used or not.**

**All basic criteria must be satisfied prior to commencing the installation and commissioning process.**

**All heaters must be earthed.**

**Flue requirements may affect the location of the heater. Refer to the "Combustion air supply/flue arrangement" section before making a final determination.**

**The flue pipe and accessible heater surfaces will be hot under normal operation and will cause burns if touched. Locate the heater such that these components cannot be touched if at all possible.**

**The heater must be positioned and installed to comply with all relevant standards and guidelines and should also meet the local and national fire regulations and insurance criteria, this is critical if the heater is to be installed within a special risk area (e.g. being; within close proximity to where petrol engined vehicles are stored or parked, where cellulose spraying takes place, where woodworking machinery is being operated, etc.).**



**The heater must not be installed within an area with unsuitable conditions, e.g. where the atmosphere is highly corrosive, has a high degree of salinity, or where high wind velocities may affect burner operation.**

**Suitable protection should be provided for the appliance when it is located in a position where it may be susceptible to external mechanical damage; for example, fork lift trucks, overhead cranes etc.**

**The location chosen for the heater must allow for the fitting of an effective flue system.**

### To properly install the heater, bear in mind that it should:

- Be installed on a level non-combustible surface capable of supporting the weight of the heater and any ancillary equipment;
- Be supported over the entire perimeter of the lower base;
- Be placed on a surface whose deflection and strength is such that it can prevent vibrations from reaching underneath;
- Be easily and safely accessible without the need for special equipment (ladders, mobile platforms, etc.);
- Respect the clearance distances in order to allow for a correct flow of air and normal cleaning and maintenance operations;
- Maintain the safety distances from flammable material;
- Be placed close to a flue;
- Be able to be connected to the fuel source;
- Be close to a suitably sized electrical supply;
- Allow for easy maintenance and inspections;

- Be fitted with the ventilation openings required by the relevant regulations.

### Do Not Install the Unit:

- In places where there is an aggressive atmosphere;
- In tight spaces where the sound level of the heater can be increased by reverberation or echoes;
- In corners where leaves could accumulate or where other objects could clog the air passage and reduce the heater efficiency;
- In pressurised places;
- In de-pressurised places;
- Outdoors, unless the unit has been supplied with a casing suitable for external installation.

The base on which the heater is positioned should not be less than 150mm (6 inches) thick and must be constructed of non-combustible material. Any combustible material adjacent to the heater and the flue system must be placed or shielded as to ensure that its temperature does not exceed 65°C.

## Clearances and access

The following clearances for installation and service access must be observed:-

In front of the heater	Equal to the depth of the heater
Behind the heater	1.0m minimum
To the burner side of the heater	1.0m minimum
Above the heater	1.0m minimum

If the heater is to be fitted at a height, then the structure of the gantry must be capable of the heaters weight (which can be found in the technical data table on page 15). In this instance, a safe working platform and access must be allowed for to enable easy and safe working access.

## Combustion air/ventilation requirements

Sufficient ventilation for combustion air purposes needs to be provided to the room in which the heater is sited. A full and unobstructed air path to the heater air inlet must be provided.

Where the heater is installed in a plant room, combustion air should be provided via permanent air vents connecting directly with the outside air at high level and low level within the room. The minimum ventilation free areas for high and low level vents are given below:-

Low Level	540cm <sup>2</sup> plus 4.50cm <sup>2</sup> per kW after 60kw
High Level	270cm <sup>2</sup> plus 2.25cm <sup>2</sup> per kW after 60kw

Where communication with the outside air is possible only by means of high level air vents, ducting down to floor level for the lower vent(s) should be used. Air vents should have negligible resistance and must not be sited in any position where they are likely to be easily blocked or flooded, or in any position adjacent to an extraction system, which is carrying flammable vapour.

Grilles or louvres should be designed so that high velocity air streams do not occur within the plant room.

The ventilation should be installed in accordance with local and national codes.

## Flue system

The cabinet heaters are designated as a Type B23 forced draught appliance where the combustion air is taken from the room space the heater is installed in and requires only a flue pipe exhausting the products of combustion to outdoors.

The heaters are designed to operate safely and efficiently with a vertical flue system or for models up to size 150 a horizontal flue system (see diagram on page 24) when installed according to the specific requirements and instructions herein.

If the heater is replacing an existing heater, be sure that the existing flue is of the correct size and is in good condition. A correctly sized flue system is required for safe operation of the heater.

For testing, the flue pipe should include a sealable test point. Ideally the test point should be at least 450mm away from the air heater flue connection socket. However if a concentric flue is attached directly to the connection sockets then the combustion should be tested through the flue outlet collar via a drilled test point which must be securely plugged on completion.

Follow the flue pipe manufacturer's installation instructions for making joints, including connections to the air heater, for passing through a building element and for support requirements.

Gasket sealed single wall seamless aluminium or stainless steel flue pipes are required. All joints must be sealed to prevent the products of combustion from leaking into the building.



**The products of combustion from the heater must be flued to the outside of the building.**

**A properly sized flue system is required for safe operation of the heater.**

**An improperly sized flue system can cause unsafe conditions and/or create condensation.**

**Failure to provide proper flueing arrangements could result in death, serious injury and/or damage to property.**

**It is important to ensure that there is an adequate air supply at all times for both combustion and heating requirements. Proper combustion air supply for a power vented Type B installation requires ventilation of the heated space.**

**Reliance on doors and windows is not permitted.**

**Natural infiltration of air may not be adequate for combustion. Modern buildings involve greater use of insulation, improved vapour barriers and weather proofing. These practices mean that buildings are sealed much tighter than in the past. Use of exhaust fans aggravates this situation.**

**Always ensure that an adequate inlet for fresh air for combustion is provided sized to suit the total installation of any combustion apparatus.**

**The flue MUST be installed in accordance with national and local regulations.**

The flue system must be designed to be:-

1. Mechanically robust.
2. Resistant to internal and external corrosion.
3. Non combustible and durable under the conditions to which it will be subjected.

Stainless steel flue is recommended as manufactured by Dinak. Contact Reznor for further details.

When designing a flue system for the appliance the designer must take into account the following points:-

1. The flue gas temperature exiting the appliance can be as high as 250°C and as low as 60°C on modulating burners.
2. Prevention of condensation within the flue and the management of drainage from the flue; for example the use of a twin wall flue will minimise the condensation.
3. The flue must be of a type acceptable to current standards.

4. Facilities should be provided for the disconnection of the flue from the heater to aid servicing and inspection.
5. This appliance does not require a draught diverter.
6. A 90° Tee condensate piece must be connected directly onto the heater spigot. From this point the flue must then rise vertically with no horizontal runs of flue pipe or 90° bends. If there is an unavoidable obstruction then the use of 45° bends is permitted. (Please contact the manufacturer if more than two 45° bends are used).
7. The flue should terminate in a freely exposed position and must be situated so as to prevent the products of combustion entering the building via any opening.
8. A flue terminal must be fitted, being sized to provide an extraction effect under virtually all wind conditions.
9. The flue installation must be designed to the latest gas regulations and any local environmental standards.
10. Where a flue passes through a combustible roof, wall, ceiling or floor, the flue pipe should be surrounded with a metal sleeve, the size of which should be sufficient to provide a space not less than 25mm between the flue pipe and the sleeve when positioned.

Single wall seamless aluminium or stainless steel flue pipes are required as a minimum. All joints must be sealed to prevent the products of combustion from leaking into the building. If the flue passes through a combustible element of the building it must be enclosed in a sleeve of non-combustible material and separated from the sleeve by a minimum of 25 mm air break.

The temperature of any combustible material near to the flue must not exceed 65°C when the heater is in operation.

The flue must be at least 150 mm away from any combustible material.

Single wall flue pipe exposed to cold air or run through unheated areas should be insulated. Where condensation is unavoidable, provision must be made for the condensation to flow freely to a point to which it can be released, i.e. a drain or gully. The condensation drain from the flue must be constructed from non-corrodible material not less than 20 mm diameter. Copper or copper based alloys must not be used for condensate drains.

Vertical flue runs greater than 3m long will require a condensate drain fitting between the flue outlet of the heater and the vertical flue pipe. Alternatively, insulated flue pipe should be considered.

Horizontal flue runs should be installed with a slight gradient of approximately 5° towards the terminal. Due consideration should be given to the possibility of condensation from the flue freezing on any footpaths that pass below the terminal.

It is important to ensure that there is an adequate air supply at all times for both combustion and heating requirements.

Ensure that the air combustion inlet opening at the appliance cannot be obstructed.

An approved flue terminal must be installed to provide an extraction effect under virtually all wind conditions. The free area of outlet openings should be at least twice the nominal area of the flue. Outlet openings should be provided preferably all round, or at least on opposite sides.

It is important for the terminal of an individual open flue system to be located so that it is not likely to be subjected to wind pressures which could restrict or reverse flow of combustion products through the flue.

The ideal position is above the highest point on the roof. It is absolutely essential that the terminal is positioned outside the building so that it is freely exposed to any wind and is not shielded by any roof structure or object to such a degree that they create undesirable pressure regions around the terminal.

The table below details the minimum flue heights for internally and externally mounted units.

The maximum flue height is 25m; if this is to be exceeded please contact the manufacturer/distributor.



**When these units are installed, air for combustion is taken from the space in which it is installed. Do not restrict the combustion air intake.**

**Ensure that an adequate clean air supply for combustion and ventilation is provided within the building in accordance with the relevant rules and regulations in force.**

Type of Roof		Location not within 1.5m of a vertical surface on the roof			Location within 1.5m of a vertical surface on the roof	
		Internal route		External route	Internal route	External route
		On ridge	Not on ridge			
Pitched	Pitch exceeding 45°	At or above roof level	1m above flue/roof intersection	1m above flue /roof	The base of the terminal to be 600mm above the level of the top of the structure	
	Pitch not exceeding 45°		600mm above flue/roof intersection	The base of the flue to be 600mm above the level of the adjacent roof edge		
Flat	With parapet	Not applicable	600mm above flue/roof intersection			
	Without parapet		250mm above flue/roof intersection			

Note: When the flue outlet is at a horizontal distance greater than 10 times the height of the parapet or structure, the terminal outlet height need be only 250mm above the roof.

## Flue Installation

All models are suitable for a vertical flue installation in the manner shown on the diagram below. A Ø130mm horizontal flue termination (wall terminal) option is available up to model 150.

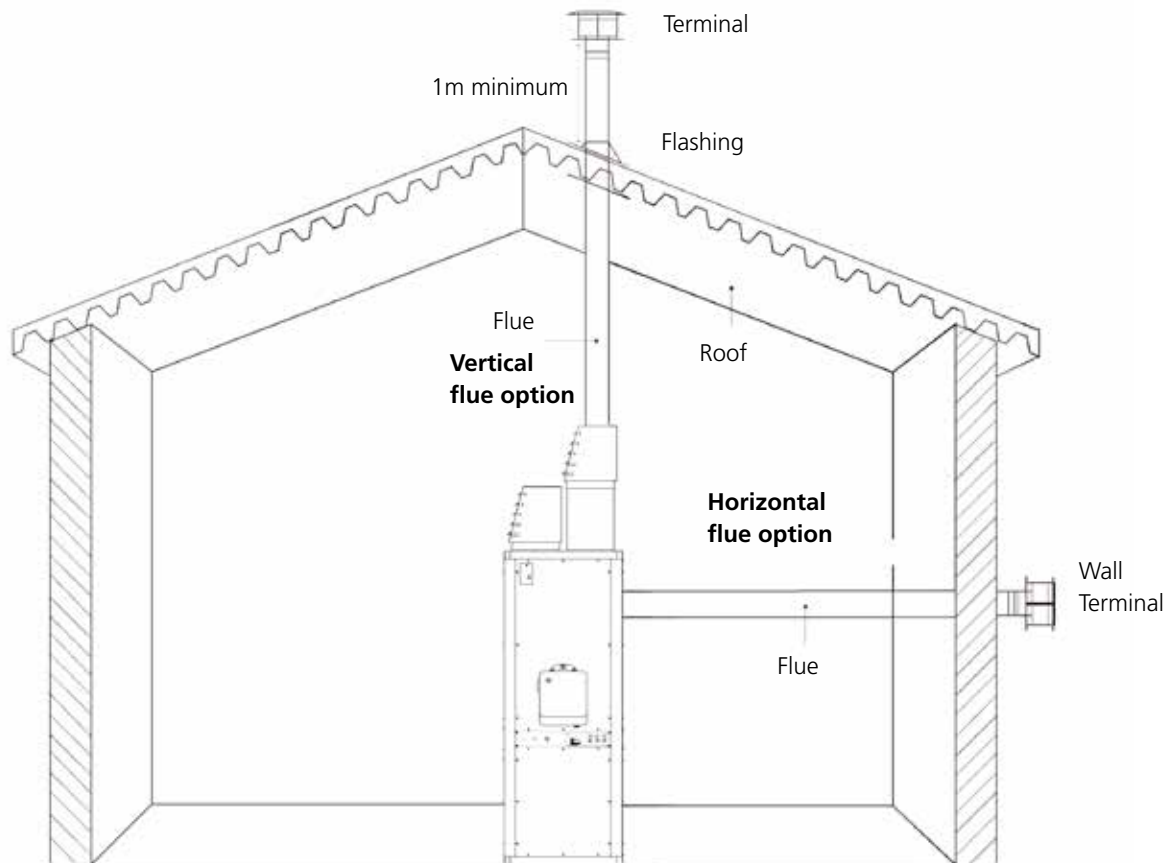

A horizontal flue installation allows for a reduced flue run because there is no requirement to install the flue to the top of the building as with normal conventional flue systems, saving on time and flue materials for the installing contractor.



## Gas installation and connection



**The installation must be purged and tested for soundness prior to commissioning.**

**Always ensure that appropriate personal protective equipment is used.**

The minimum inlet gas pressure at the heater should be 20mbar static for natural gas (17.5mbar dynamic pressure).

A competent and/or qualified engineer is required to either install a new gas meter to the service pipe or to check that the existing meter is adequate to deal with the rate of gas supply required. Installation pipes should be fitted in accordance with national standards so that the supply pressure and volume, as stated in the technical data table on page 15 previously will be achieved.

It is the responsibility of the competent engineer to ensure that all relevant standards and codes of practice are complied with in the country of installation. Pipes of smaller size than the heater inlet gas connection must not be used. The complete installation must be tested for soundness as described in the country of installation. Gas piping must be supported with pipe hangers, metal strapping, or other suitable material.

Service pipework must terminate at an approved isolating valve and be adjacent to the position of the heater. The connection to the heater can be made by way of either an approved flexible coupling, or rigid connection. Threaded connections must comply with ISO288/1 of ISO 7/1, further information concerning the accepted practice in European countries is detailed in BS EN 17082:2019. The diameter of the pipework from the isolating valve to the burner connection must not be less than the diameter of the burner connection inlet.

As far as gas burners are concerned, we suggest placing a leak detector near them, which should operate a solenoid valve in the gas supply line that will stop the gas flow in case of any accidental leakage.

The gas supply line should be installed by a qualified person, in compliance with all the relevant Laws, Regulations and Rules. Refer to the designer of the system.

## Oil Installation/connection



**Prolonged exposure and contact with gas oil or heating oil can result in the natural oils being removed from the skin and can result in dermatitis.**

Always ensure that the appropriate personal protective equipment is used.

### Fuel supply



**Galvanised or plastic pipe work and fittings must not be used. (See BS 5410 Part 2)**

The constraints of the application will, to a large extent, determine whether it is preferable to use a single pipe gravity feed system or a two pipe pumped system is more appropriate. Where more than one appliance is to share a common supply it will be necessary to use a pressurised ring main system.

All pipe work must be constructed and installed so that it does not permit the ingress of air. The construction, size, and position of the oil storage tank must take account of the current regulations, as well as suiting the requirements of the installation.



**On pumped systems always check that the pump is correctly set up prior to operation.**

**Ensure that valves are open allowing a free flow of oil through the system.**

In order to promote trouble free operating it is necessary that the oil within the storage tank and oil line does not fall below the cold filter plugging point (cfpp). In the UK and with class D fuel (also referred to as gas oil), the cfpp critical temperature is -4°C for the summer grade. The cfpp critical temperature for the winter grade is -12°C.

If summer grade fuel is stored for winter use in areas prone to severe frosts and low temperatures it will be necessary to insulate or even heat the supply tank and pipework.

**Note: The fuel supplier should be contacted prior to installation so that any requirements concerning delivery, transport, storage and use can be addressed before work commences.**

The inlet pump pressure must not exceed a maximum of 0.4 bar; beyond this point gas is liberated from the oil.

## Storage tank

An externally painted steel storage tank to BS 799 part 5 or a medium density polyethylene oil tank OFTEC certified to OFS T-100 may be used. Local, national, European and fire regulations must also be complied with and the tank must include:

- A fuel level gauge (not made from glass)
- A vent pipe with a diameter greater than that of the filler and featuring a weatherproof termination.
- A sludge valve.
- An outlet valve situated at the opposite end of the tank to the sludge valve.
- A filler pipe connection situated at the opposite end to the outlet valve.

The size of the storage tank must take account of the estimated consumption and any quantity price breaks offered by the oil supplier. It is preferable to install the tank outside, however, if this is not practicable and the tank has to be installed indoors advice must be sought about its positioning, especially so far as fire regulations are concerned.

If a separate fire resistant chamber cannot be provided for indoor installations, a catchment pit with a capacity 10% greater than that of the storage tank must be provided. Storage tanks can if necessary be sited on a roof, but this is subject to special regulations as well as local authority approval and compliance with fire regulations. Reference to BS 5410 part 2 is strongly suggested.

It is advisable to leave the tank unpainted on the inside, but to paint the outside with a proprietary grade of anti-corrosive paint.



**A galvanised or open topped tank is strictly not allowed. All oil storage tanks require a bund.**

The Control of Pollution (Oil Storage) (England) Regulations 2001 should be consulted prior to installation.

## Single pipe system (gravity feed)

For installations where the oil tank is 200mm or more above the level of the fuel pump the principle of gravity feed may be used. The draw off point for the supply to the burner must not be positioned any lower than 100mm above the bottom of the tank.

Where a return valve is fitted this must be tamper proof to prevent inadvertent operation.



**If the valve is closed when the pump is running the oil pressure can be increased sufficiently so as to cause damage to the seals within the pump.**

The return oil should be discharged (preferably) through an elbow onto a tank plate situated within the tank, this should be positioned so as not to introduce air or air bubbles into the draw off pipe.

## Two pipe system

This is used where the oil storage tank is lower than the pump.

Access for the fuel feed to the burner should be via a suitable tapping made in the top of the tank, and the fuel feed pipe should extend to not less than 100mm above the bottom of the tank. A non return valve with a metal to metal seat should be fitted, especially if the return pipe work is terminated at a level above the draw off tube. The non return valve must be removable for service and maintenance purposes, and the return pipe from the pump must therefore be extended down into the tank to the same level as the suction pipe.

The presence of a tamper proof isolating valve fitted within the return pipe is only required if there is a risk that oil will siphon out of the tank if the return pipe is disconnected at the pump during maintenance or servicing and if the non return valve has been omitted.

## Pressurised ring main system

This system is used to supply a number of units from a common storage tank.

A booster pump is used to provide the pressure to push the oil around the ring main and back to the tank.

Pressure reducing valves should be fitted on the delivery pipe to each heater to ensure that the pressure at the burner pump is less than 6 psi.

 **The internal by-pass plug must be removed from the burner pump when used in a pressurised ring main application.**

## Pipework and fittings

 **Galvanised or plastic pipe work and fittings must not be used. (See BS 5410 Part 2)**

 **All joints must be sealed properly, if necessary using PTFE tape or other approved sealing media. The pipe work must be effectively sealed so as to prevent the ingress of air. The fire check valve must be operated by way of a fusible link positioned so that it is above the burner.**

**Figure 1 Pressurised oil feed system**

1. Gate valve
2. In-line filter
3. Pump
4. Relief valve
5. Pressure gauge
6. Pressure reducing valve
7. Return to tank

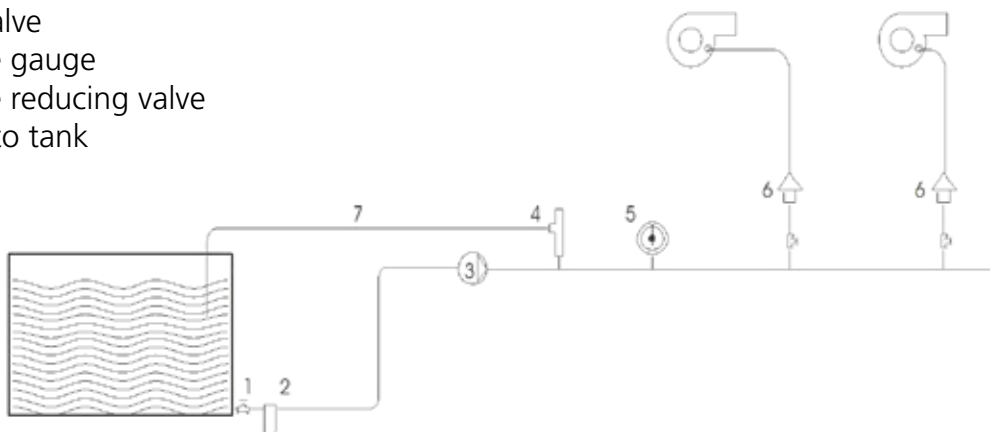

The pump suction should not exceed a maximum of 4 metres. Beyond this limit gas is released from the oil. Oil lines must be completely airtight.

The return line should terminate within the oil tank at the same level as the suction line; in this case a non return valve is not required. Should, the return line terminate over the fuel level, a non return valve is essential. This solution, however, is less safe than the previous one, due to the possibility of leakage in the valve.

Priming the pump: start the burner and await priming. Should lock-out prior to arrival of the fuel, wait at least 20 seconds before repeating the operation.

## Ducted Models

---

It is essential that the correct amount of air is provided through the heater and should be evenly distributed when entering the heater.

Ductwork must comply with all current regulations and must be sized so that the duct pressure drop/resistance is less than the external static pressure capacity of the heater.

All delivery and return air ducts, including air filters, jointing and any insulation or lining must be constructed entirely of materials which are fire resistant, are of adequate strength and dimensionally stable for the maximum internal and external temperatures to which they are to be exposed during commissioning and normal operation.

When selecting materials, account must be taken of the working environment and the air temperatures which will result when the overheat limit thermostat is being commissioned.

Where inter-joint spaces are used as duct routes, they should be suitably lined with fire-resisting material.

A full and unobstructed return air path to the air heater must be provided.

If the air heater is to be installed in a plant room, the return air and warm air discharge arrangements must be such as to avoid interference with the operation of the flue by the air circulation fan. The return air intake and the warm air outlet(s) should therefore be fully ducted, in the plant room, to and from the heater, respectively. The openings in the structure of the plant room through which the ducting passes must be fire stopped.

Ductwork materials selected must be of low heat capacity, and it is preferable that all warm air ductwork is thermally insulated. Where ducting may be subject to deterioration from exposure to moisture or high humidity, material selection and insulation are prime considerations. Joints and seams must be airtight and fastened securely and designed to remain so, even when operating at high temperatures.

Adequate support must be designed into the layout of the ductwork to ensure that the integrity of the seams and joints is maintained. The support must be independent and separate from the heater and the ducting, to allow for free movement during expansion and contraction.

Where ducting passes through walls or partitions, sufficient clearance must be left irrespective of any fire stop requirement, to allow for expansion and contraction. Failure to adhere to these latter two points can result in the generation and transmission of excess noise.

Where ducting is installed in concrete flooring a permanent membrane must be used to isolate the ducting from the corrosive effect of the alkaline salts within the concrete.

Care should be taken to ensure that soft insulation material does not become compressed and thereby lose its insulation effectiveness.

## Nozzled Models

For free blowing applications it will be necessary to complete the final assembly before continuing with the installation. The nozzles should be pushed home on the spigots and positioned to provide the desired airflow. When in the correct position fix in place with drill screws.

- Ensure louvres are adjusted outwards and ensure blades are not resonating.
- The nozzles should be securely fixed in their desired position on completion of commissioning.



**Care should be taken when adjusting the louvre blades on the outlet nozzles, closing too many blades could lead to the heater tripping on high limit. Should this occur please reset the limit device and gradually open nozzles until the heater no longer trips.**



**Do not remove or blank off a nozzle head or connect ductwork to a nozzle outlet.**

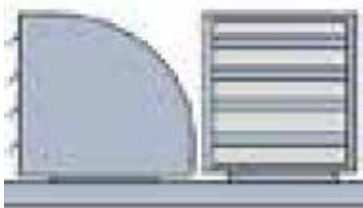

Figure 2 Nozzle system

## Condensate drains

Gas fired high efficiency condensing heaters are provided with a condensate drain ( $\frac{3}{4}$ " BSP for units up to size 150 and 1" BSP for units from size 180 and above), which the installer should connect to the nearest foul drainage point as part of a suitably designed and sized condensate disposal system. The condensate connection is at the rear of the heater.

The drainage system must:-

- have a 150mm trap fitted inline before connecting to a drain point. A condensate pump can be installed after the trap if required.
- utilise galvanised or stainless steel pipework, including the trap. Plastic pipework can be used after the trap.
- not reduce in diameter throughout its length.
- comply with all local and national regulations.
- terminate at a drain or waste pipe.
- be insulated if run externally or in areas with low ambient temperatures.

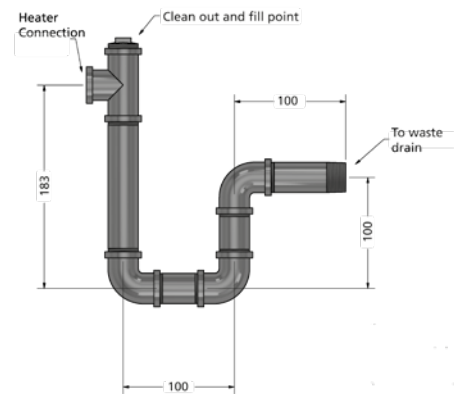

**Do not use plastic condensate pipe and connections as the temperature of the condensate may be high at the outlet to the drain.**

**Check local and national regulations regarding the discharge of condensate.**

**The trap MUST be filled prior to operation.**

## Electrical installation/ connection



**Always isolate from the mains electrical supply before commencing work on the heater.**

**The electrical installation may only be carried out by an appropriately qualified person in accordance with the current Rules and Regulations in force.**

**This appliance must be earthed. All wiring must be in accordance with current IEE Regulations and all local regulation that apply.**

Cabinet heaters are available for 415V 50Hz 3 phase supplies only.

The electrical supply must be as specified in the technical data table on page 15 previously and suitable for the heater, must be run within conduit to a point adjacent to the heater and be terminated to provide an isolation point that will prevent remote or inadvertent activation.

Cables, conduit and fittings that are used to make the connection between the isolator and the heater must conform to the appropriate local and national regulations.

All heaters are supplied fused and pre-wired and must be earthed.

The electric and controls terminations are located on the side of the heater housed in an interface panel.

All heaters are compatible for interfacing with building management systems and a 0-10V DC control signal is required as standard on modulating heaters.

Check that the air heater is well earthed and that an earth leakage test is carried out.

Final connections for any additional external controls must be completed on site, and must be carried out according to local and national regulations. Separate user information is provided for the burner which forms part of the product information pack which accompanies every heater when despatched.

Always ensure that the appropriate personal protective equipment is used.

Ensure that all cables and installers wiring are appropriately fixed and that they do not touch the flue or combustion collector box.

The heater electric panel is pre-installed with the burner, control and safety thermostat of the FAN-LIMIT device connected.

Electrical connection should be carried out in the following order:-

1. General power supply;
2. Connections to the blown burner;
3. Connections to the various external safety systems (fire dampers, fire protection, etc.).

Please note the following:-

- Electrical connections must only be carried out by qualified engineers
- If confused, please contact manufacturer for further clarification.
- Install upstream of the unit a thermal magnetic differential circuit breaker suitably sized according to the regulations in force.
- The unit must be connected to an efficient earthing system. The manufacturer shall not be held responsible for any damage caused by failure to earth the appliance.
- When connecting the earthing system, take care to leave the earth wire slightly longer than the other wires; in the event of the wires being accidentally pulled, the earth wire will be the last one to be removed.
- A qualified electrical engineer must check that the cross-section of the cables and the electrical system are suitable for the maximum power absorbed by the unit indicated on the information plate.
- Respect the polarity of the connection of the power supply (phase - neutral) and make sure that the direction of rotation of the fans is correct.

- The electrical cables must be positioned away from hot and/or cold surfaces, or areas with sharp edges.
- Do not use water pipes or gas pipes to earth the unit.
- For input and output of the electrical wires, use the dedicated cable clamps on the unit

The appliance must always be powered.

Operation must only be obtained by the settings of the controls.

## Controls

The heater can be used with most Building Management Systems.

### Standard Efficiency Burner

All models with the exception of the high efficiency natural gas fired condensing units have a modulating burner with a 2:1 turndown. The burner 7 pin plug/socket terminals should be connected in the following manner:-

1. 240V & N supply
2. T1 & T2 is the enable; T1 & T2 must break when up to temperature. All interlocks must be wired in series with T1 & T2. (The burner must be interlocked with the supply fan).
3. Terminal S3-240V burner lockout indication if required.
4. Terminal B4-240V burner lockout indication if required.

The burner 3 pin plug/socket terminals should be connected in the following manner:-

1. L-10V DC modulating signal connection
2. N-10V DC modulating signal connection

A 15 minute supply fan over run on burner shutdown MUST be provided.

For ON/OFF control only, omit 3 pin burner plug.

### High Efficiency Condensing Burner

High efficiency natural gas fired condensing units have a modulating burner with a 4:1 turndown. The burner 7 pin plug/socket terminal connections should be connected in the following manner:-

1. 240V & N supply
2. T1 & T2 is the enable; T1 & T2 must break when up to temperature. All interlocks must be wired in series with T1 & T2. (The burner must be interlocked with the supply fan).
3. Terminal S3-240V burner lockout indication if required.
4. Terminal B4-240V burner lockout indication if required.

The burner 3 pin plug/socket terminals should be connected in the following manner:-

1. L-10V DC modulating signal connection
2. N-10V DC modulating signal connection

A 15 minute supply fan over run on burner shutdown MUST be provided.

For ON/OFF control only, omit 3 pin burner plug.

If you require any further information or you have any special requirements please do not hesitate to contact our Technical Department.



#### **Electrical Shock Hazard.**

**Use extreme caution while working on this appliance.**

**Failure to follow these instructions can result in death or electrical shock.**

**Only competent and suitably trained engineers should carry out work on this appliance.**

# COMMISSIONING



**Commissioning MUST be carried out by a competent Gas Safe registered engineer.**

**This section must be read in conjunction with the commissioning instructions given in the separate burner manual.**

1. Visually check the full system to see if it is in accordance with this manual and to current/GAS SAFE legislation and IEE regulations.
2. Check combustion air is adequate to the plant room or surrounding area.
3. Check associated electrical wiring are correct and terminated tightly and MCB/fuse ratings are correct.
4. Ensure that the gas pipework is sized correctly and the relative documents for pressure testing, soundness and purging are available. It is the responsibility of the commissioning engineer to check for system soundness from the main inlet to the servicing stop tap on the inlet of the valve.
5. Ensure that the inlet gas pressure is no greater than 75mb static and no less than 17.5mb with the heater running.
6. Make sure that all dampers are set and diffuser outlets are open to give the correct air flow.
7. Check that there is an interlock with the supply fan and burner so that the burner cannot run without the supply fan e.g. an air pressure switch across the supply fan in series with the enable circuit between terminals 1 & 2. The supply fan MUST be set to run on for 15 minutes after burner shutdown, on a shutdown condition. Terminals 1 & 2 are also used to wire thermostats and time switches in series to switch the burner on and off.
8. Terminals 6 & 7 are required for high/low operation (if fitted); when the circuit is made it is high and when it is broken it is low.
9. Ensure that the thermostat wired between terminals 1 & 2 is closed and turn the gas supply on to make the gas pressure switch and turn the commissioning stop tap off.
10. Switch the burner on. The burner should run through its cycle and after the ignition spark goes out, the burner should lockout on flame failure on the control box.
11. Before opening the commissioning stop tap ensure that the burner air damper is open. Disconnect the main valve. Leave the pilot connected. Open the commissioning tap and switch the burner on. The burner should go through its sequence and fire but stay on. At this point in time, check the start gas rate which should be no greater than 20% of the total output. This is preset in the factory and must be checked.
12. When satisfied with the pilot pressure, switch the burner off and reconnect the main valve, turn the main gas valve on and turn the gas valve throttle to minimum. Switch the burner back on and make the high/low circuit. Now the burner should fire and go to full fire. Set the head pressure in accordance with the rating plate. Break the circuit between terminals 6 & 7 so that the valve goes to low fire and set it in accordance with the rating plate pressure. The governor must be throttled down until it takes control of the head pressure, then be left at that setting. The main gas valve throttle can be locked in to position when the gas head pressure is set.



13. When satisfied with the gas settings, the CPI switch (if fitted) requires setting on; they are integral and are factory set. For further information please see the separate burner manual.
14. Carry out a full emissions check with a flue gas analyser. The parameters are to be set as specified in this manual by the adjustment of the burner air damper, which, when satisfied must be locked off securely. Then the burner requires setting to 50% turndown, which can be done by breaking the circuit between terminals 6 & 7. Check the emissions are satisfactory once the circuit has been broken. They should be approximately 10% to 11% O<sub>2</sub> on low fire and CO emissions should be below 100 PPM. Note the air damper is not altered between high and low, it is set on high.
15. The high and low air pressure switch must be set after the damper has been locked off. The low air pressure switch is set by turning it up until it locks out and then moving it back 1.2mb on the pressure switch. Set the high air pressure switch to 1.2mb above the lockout pressure.
16. The low gas pressure switch will be pre-set in the factory to 10mb.
17. Check the strength of the flame sensing device by removing the link on the burner which connects the flame probe to the control box. Connect a multi-meter in series to give reading in uA. The signal strength should be at least 70uA for U.V. and 6uA on flame rectification.
18. After running the unit for a period of one hour, take a running temperature from the fan limit side of the thermostat. Set the over heat to 20°C above the running temperature.
19. The supply fans should be shut down once when the burner is running to test the overheat device and the fans must be switched on as soon as the unit locks out on overheat.
20. All gas nipples must be replaced and checked for tightness and checked with leak detection fluid.
21. A leak detection test is to be carried out with leak detection fluid and an electronic leak detector on the gas train whilst the burner is running to see if there are any leaks in the burner gas train. A soundness test is to be carried out on all gas work.
22. Make a full record of combustion data on the commissioning sheet provided. The commissioning sheet should include the following:
  - Model and Serial Numbers.
  - Heater running temperature and overheat settings.
  - Full thermal input.
  - Governor pressure setting (pilot for start gas and main for full fire).
  - Gas flow rates for full fire.
  - Burner damper setting and pressure switch settings.
  - Flame signal strength on full fire.
  - Exhaust gas O<sub>2</sub>, CO<sub>2</sub>, CO and temperature.

After setting all air pressure switches and valves etc, mark the position or lock off if possible.

Typical flue gas readings are given below:-

O <sub>2</sub>	4% to 5%
CO <sub>2</sub>	9.5% to 10%
CO	Up to 100ppm Typically 20 ppm
Flue stack temp	Up to 250°C

## Unit operation

---

The burner should start its safety sequence and then fire up. When the heater achieves 35°C the supply fan will cut in and the heater is up and running. When the room space is up to temperature the burner will stop and the supply fan will run on until the fan control reaches 25°C, whereupon the supply fan will shut down. The heater will then switch on and off as required via the day thermostat and time clock.

If the heater fails to start, check the burner lockout and high limit resets as referred to in fault finding following. If any further investigation is required or the heater repeatedly locks out then a Gas Safe registered engineer must be called to investigate further.



**You must not electrically isolate the heater when in full fire; always wait until the burner stops and the supply fan over runs to dissipate the residual heat before electrically isolating.**

**For summer ventilation switch the on/off switch to off and set the fan switch from auto to manual.**

## Overheat protection

---

Overheat protection is fitted such that in the case of the air flow falling below the minimum necessary for safe operation of the heater (which may be caused by failure of the supply fan/motor, dirty filters or inlet damper failure), the high limit will trip out and will require manually resetting.

If this happens on a regular basis it must be investigated by a competent registered engineer as this could cause serious damage to the heater.

The limit control provides protection for the heater should the temperature rise above a safe level.

If an overheat condition occurs, the limit control will shut down the burner and hold it off until the manual reset button is pressed.

To reset the overheat:-

1. Remove the plastic cap with a screwdriver
2. Lift the white lever/tab to reset
3. Replace the plastic cap

Ensure that the fan and lit setting are as follows:-

Fan setting	35°C ON/25°C OFF
High Limit	20°C above normal running temperature no greater than 100°C (see attached label on heater for setting).



**If the limit requires re-setting more than once after the first re-set, then a competent engineer must be called to investigate further.**



**When the heater control is integrated with a building management system, the fan will be operated via the BMS controls and all interlocks must be fitted to ensure the burner cannot start until the supply fan is running.**

**On burner shutdown the supply fan overrun must be set to continue running for 10 – 15 minutes to dissipate residual heat.**



Fig 3 Overheat reset

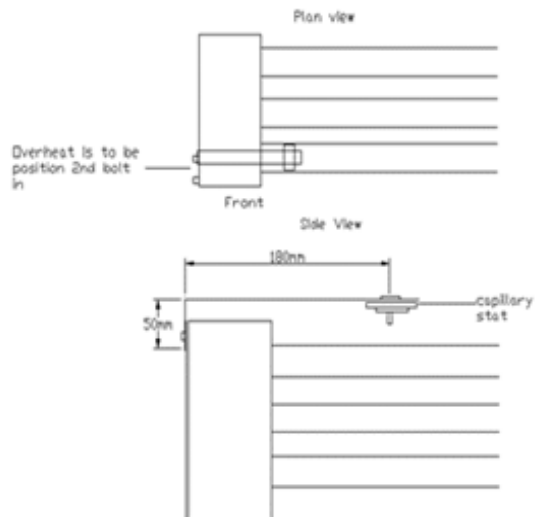

Fig 4 Overheat position

# MAINTENANCE



**Servicing must only be carried out by a competent and suitably qualified engineer (Gas Safe certified for a gas fired unit).**

**Before carrying out any works, ensure that the unit is electrically isolated, with the isolator padlocked off and that the fuel supply (gas/oil) is shut off.**

**Only manufacturers recommended spare parts should be used.**

**The heater should be fully serviced and recommissioned every year. If the flue gas passages in the heat exchanger, combustion chamber or flue chamber become blocked, the heater can overheat causing the unit to shut down via the overheat thermostat.**

## To clean the heat exchanger

---

The heat exchanger must be cleaned from the front and rear of the appliance after first removing the burner assembly.

## Burner removal

---

1. Disconnect the electrical supply to the burner by removing the multi-pin plug from the socket on the Heater interface panel.
2. Disconnect gas valve plugs.
3. Unscrew gas union assembly at inlet to gas train and at entry into burner mounting flange and remove gas train assembly.
4. Remove four fixing screws holding burner to heater side and lift away burner.

5. Fully service the burner in the following manner and replace electrodes if required:-
  - a. Remove the fan limit thermostat.
  - b. Remove the front outer case panel.
  - c. Remove and support the flue.
  - d. Remove the rear panel.
  - e. Remove the heat exchanger cover plate, front and rear.
  - f. Brush any deposits from all of the flue ways using a stiff brush. Also brush down the heat exchanger tubes.
  - g. Remove any soot from the bottom of the combustion chamber with a vacuum cleaner.
  - h. Inspect soundness of combustion chamber/heat exchanger.
  - i. Replace all items in reverse order.

Fit new gasket or seal to the gas exchanger box, cleaning the door where necessary.



**If it is found that the area in which the heater is installed has become wet/flooded, the heater must be electrically isolated immediately and an investigation carried out to find out if any water has penetrated into the heater controls. If so, ensure they are dried out properly before reinstating the electric supply.**

## Burner maintenance

---

Refer to the separate burner manual supplied with the heater.

## Heat exchanger maintenance

---

The heat exchanger is of multi-tube construction with removable access clean out doors at either end. Access plates are secured by brass nuts, sandwiching glass wool webbing type gasket material between the heat exchanger flange and the access doors. When removing the doors it is important to inspect the gasket material and replace if necessary.

It is important that the tubes should be inspected and swept out if necessary, replacing the Gasket Material – the material is of glass wool webbing 25mm x 3mm thick in strip form. The method of securing it is to have strips overlapping, and to cut through both surfaces with a sharp knife to give an exact join. Self adhesive webbing is easier to secure.

## Routine maintenance

---

### Weekly check

- Check that there are no apparent leaks from the unit.
- Clean washable air filters if fitted; replace filters where necessary.

### Quarterly check

- As weekly check and also:
- Check the flue for condensation.
- Remove the Burner Inner Assembly – clean and replace.

### Annual inspection

- As quarterly check and also:-
- Clean heat exchanger surface.
- Check the tightness of the motor bolts.
- Inspect and adjust electrical connections.
- Check all wiring and tube connections.
- Remove the burner inner assembly – clean and replace.

- Start the heater and check CO readings, stack temperature efficiency and CO level.
- Check the combustion air supply and check the smoke reading.

## Fan assembly

---

Inspect the fan blades to see they are not damaged and that there is no excessive build up of deposits that could give an imbalance via the access panel on the side of the heater. If necessary clean the fan blades.

## Gas/oil control valve maintenance

---

No regular maintenance is required for the control valve, however, the following checks should be carried out to the associated pipework:-

- Check all pipes and joints to ensure there are no cracks or leaks. Any cracks in the pipe work or joint must be repaired.

## Cleaning of heater

---

The heater can be cleaned externally using a damp cloth with a light detergent. Please note: this is on the outer panel only, away from all of the electrics. No substance should be used that will cause harm to the surface of the metal or remove paint etc.

Please Note: You must not use water on unpainted galvanised finished surfaces.

# REMOVAL AND REPLACEMENT OF PARTS

## Multi-block gas valve

---

1. Isolate electric and gas supplies.
2. Remove DIN plugs by using a terminal screwdriver to undo locking screw.
3. Undo valve flanges with 13mm spanner. Lift out valve assembly.
4. Replace and re-assemble in reverse order taking care that the O-rings are in position.
5. Check for gas soundness and re-commission heater.

## Fan and limit stat

---

1. Isolate electric supply.
2. Remove outer casing and disconnect wires. The wires are held in by spring terminals which will release by pushing a small screwdriver into the slot next to the wiring termination.
3. Remove fixing screws which secure stat to front of panel, carefully withdraw stat from heater and remove casing.
4. Re-assemble in reverse order and check settings, adjust if required to fan on 35°C, fan off 25°C, high limit 90°C.

## Burner replacement

---

1. Refer to separate burner manual.

## Recommend Tools to be used

---

- Spanner 10mm, 13mm and 17mm
- Screwdriver – Terminal, medium flat blade and philips medium
- Stillsons – 14" and 18"
- Allen keys – standard metric set, 1.5mm – 10mm
- Side cutters/pliers
- Multi-meter
- Manometer
- Flue – brush 3" head for exchanger tubes

# SPARE PARTS

<b>Item</b>	<b>Part Number</b>
Supply fan	
Overheat	
Fan stat	
Relays	
Toggle switch	
Red indicator	
Green indicator	
Orange indicator	
Please refer to the separate burner manual supplied with the heater for details of the spares associated with the burner.	

# TROUBLE SHOOTING

FAULT	PROBABLE CAUSE	PROCEDURE
Burner lockout	Burner fault	Refer to fault finding chart in the burner manual supplied with the unit.
Overheat trip	Low supply air volume	Change/clean filters if fitted Check fan operation Check damper operation Check outlets for blockages Check inlet for blockages
Burner held off	No enable signal	Check BMS controls via T1 & T2 in heater interface panel Check green light illuminated Check burner enable relay Check overheat Check fuses to burner Check for burner lockout and reset
Main fan runs continuously	Electrical	Check if Summer/Winter switch set to summer Check if fan thermostat set too low Check for faulty fan Check for faulty limit stat
Main fan fails to run	Electrical	Check for faulty fan motor Check for faulty fan Check for faulty limit stat Check for faulty contactor Check if motor is held off by an overload condition
Please refer to the separate burner manual supplied with the heater for details of the fault finding / trouble shooting regimes associated with the burner.		



# USER INSTRUCTIONS



## If you smell gas:-

1. Open all windows and doors
2. **DO NOT attempt to light any appliance**
3. **DO NOT use electrical switches**
4. **DO NOT use any telephone in the building**
5. Evacuate the building
6. Immediately call your gas supplier after evacuating the building and follow all instructions given by them
7. If you cannot reach your gas supplier, contact the Fire Brigade

Use the electrical isolator and gas /oil isolation valve to shut down the appliance in an emergency only.

The heater should not be electrically isolated during normal operation; doing so without a fan run on for 10 minutes will cause serious damage to the heater.

If the limit thermostat persistently operates, there is a fault which must be investigated by a qualified engineer registered with Gas Safe.

Do not store or use petrol or other flammable vapours and liquids in the vicinity of this or any other appliance.

Some objects will catch fire or explode when placed close to the heater.

Failure to follow these instructions can result in death, injury or property damage.

## General

Once the controls have been fully installed and proved with the heater (all interlocks proved etc.), the supply air has been balanced and only when the heater has been fully commissioned by a qualified registered engineer (Gas Safe), you are now able to use your Heater safely.

## Burner Start up

1. Ensure Burner and Heater On/Off Switch is on.
2. Fan switch is in auto position. If the heater is controlled via a BMS then the supply fan should be running before the burner can start.
3. Make sure the time clock and thermostats are calling for heat or that the BMS is giving an enable signal to terminals 1 & 2 in the interface panel.

## Burner Shut down

1. Ensure Burner and Heater On/Off Switch is off.
2. Fan switch is in auto position. The fans should run on for at least 10 minutes or until the fan limit is below 25°C to cool heat exchanger.
3. Make sure the time clock and thermostats are not calling for heat or that the BMS is not giving an enable signal to terminals 1 & 2 in the interface panel.

## Simple fault finding

Some possible reasons for the heater not operating are:-

1. Gas/fuel oil supply not turned on
2. Electrical supply not turned on
3. Timer and/or thermostat is not calling for heat

4. The limit stat may have operated due to an interruption of the electrical supply or a fault with the distribution fan
5. If the burner fails to ignite for any reason, it will go to lockout. This will be indicated by the red light on the burner. Press in and release the lockout reset button; call a registered engineer if this does not rectify the problem.
6. Lockout should not occur during normal operation of the heater. If it does, it indicates that there is a fault condition which must be corrected.

# Notes

A large grid of graph paper, consisting of 20 columns and 30 rows of small squares, intended for taking notes.



**NORTEK GLOBAL HVAC (UK) LTD**

Fens Pool Avenue  
Brierley Hill  
West Midlands DY5 1QA  
United Kingdom  
Tel 01384 489700  
Fax 01384 489707  
reznorsales@nortek.com  
www.reznor.eu