

## INDIRECT FIRED AIR HEATER

(EBM-POW)

### INSTALLATION AND OPERATING MANUAL

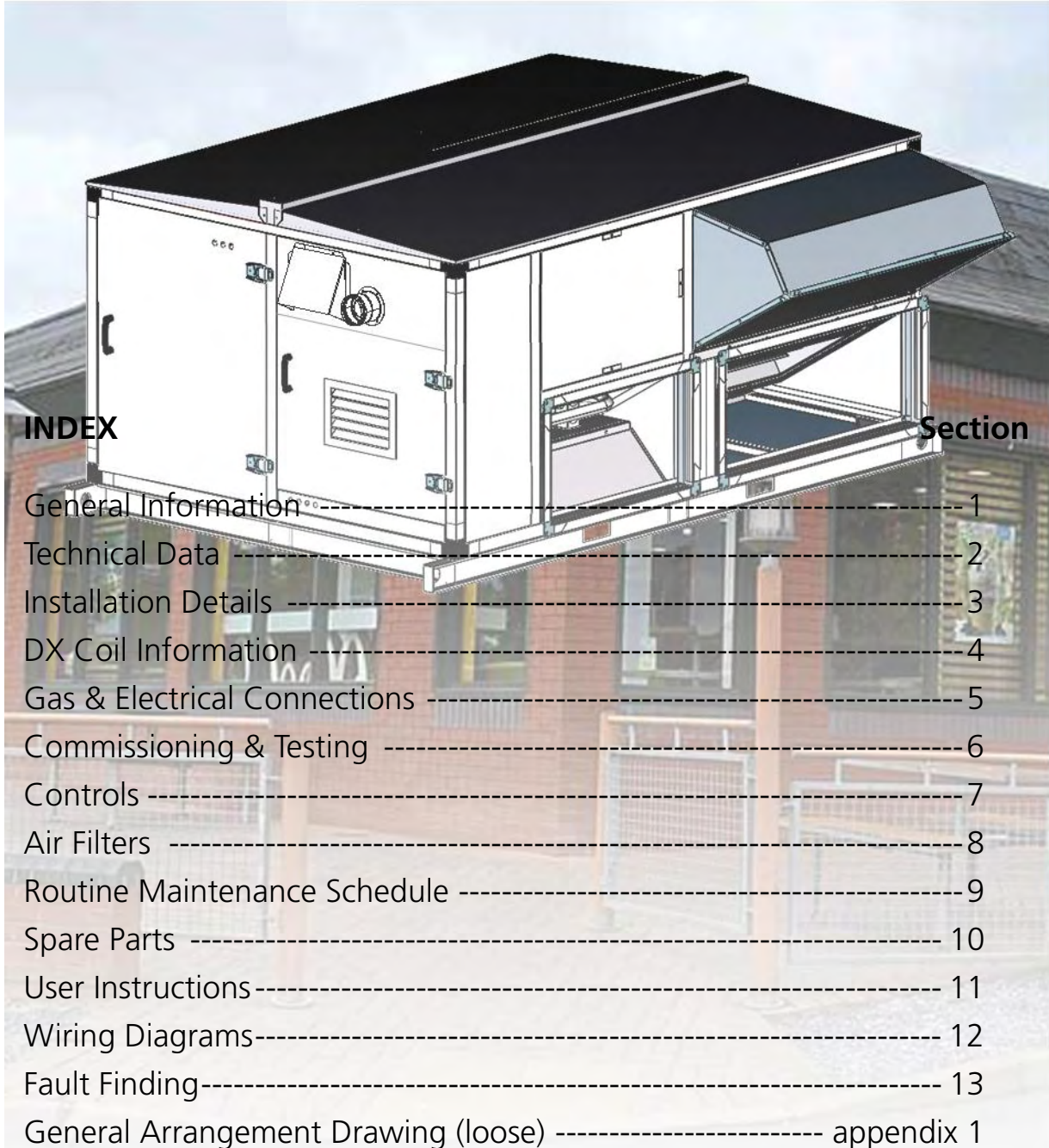

#### INDEX

#### Section

General Information	1
Technical Data	2
Installation Details	3
DX Coil Information	4
Gas & Electrical Connections	5
Commissioning & Testing	6
Controls	7
Air Filters	8
Routine Maintenance Schedule	9
Spare Parts	10
User Instructions	11
Wiring Diagrams	12
Fault Finding	13
General Arrangement Drawing (loose)	appendix 1

#### WARNINGS

- 1 This appliance must only be installed by a competent person in accordance with the requirements of the Codes of Practice or the rules in force.
- 2 All external wiring MUST comply with the current IEE wiring regulations.
- 3 Warning this appliance must be earthed.

Part No. 703029



# 1. General Information

Before installation, check that the appliance as described on the packaging label is in accordance with the correct type and model as specified on the data plate and complies with the site requirements.

Please read this document before commencing installation.

Check that the local distribution conditions of electricity supply, type of gas and pressure of the appliance are compatible.

The installation must comply with the requirements and recommendations of British Standards BS 6230 1991. "Installation of Gas Fired Forced Convection Air Heaters for Commercial and Industrial Space Heating".

The installation must also be in accordance with relevant requirements of The Gas safety (Installation and use Regulations) and (Amendment regulation 1990) and the Building and Electrical Regulation (in GB and IEE Regulations). The requirements of the Local Building Standards Office, the premises Insurance undertaking and the Fire Authority must also be observed.

Unauthorised modification of this appliance or departure from use in the manner for which it was intended by the manufacturer or installed in a manner contrary to these instructions, may constitute a hazard or jeopardise all warranties. Deviations should only be carried out after formal consent has been obtained from the manufacturer.

Ensure the environment in which the air heater will be installed will not create a hazard, i.e, where excessive (volatile) dust, flammable or corrosive substances and/or vapours and combustible materials may be present. When installing outdoor heaters care must be taken to ensure that unauthorised access to the building cannot be gained via the appliance or its ductwork system.

This appliance has been tested and set according to the data plate before leaving the factory.

After installation the appliance must be fully commissioned and the settings re-checked.

This appliance incorporates indirect gas fired heat exchange modules. The modules are purpose designed to be incorporated into air heating appliances and the modules comply with CE directives.

This appliance is suitable for operation within a -10°C to +40°C temperature range.

## Invalidation of guarantee

The following misuses or maltreatment of Nordair Niche equipment will render all guarantees, as set out on the Conditions of Sales, void.

- Failure to install, set up or put to work any part of the equipment as specified in Nordair Niche installation, operation and maintenance instructions.
- Attempting to operate motors and other electrical equipment with an electrical supply other than that designated on the motor name plate, or failing to connect and protect such equipment in accordance with I.E.E Regulations and local by-laws.
- Failure to notify Nordair Niche of equipment damaged on receipt in writing within five days.
- Failure to run equipment within the design specifications as notified at the time of order.
- Modifications to designed arrangement or performances without the prior written approval of Nordair Niche.
- Damage caused to equipment on site through lack of adequate protection from the elements or misuse by other trades.
- Failure to observe all normally accepted engineering practices during installation, commissioning and subsequent operation of equipment.

## **IMPORTANT NOTE**

**DO NOT USE IMPACT DRIVERS ON PANELS OR DOOR CLAMPS!  
USE M5 ALLEN KEY ONLY!**

# 1. General Information cont.

Before installation, check that the appliance as described on the packaging label is in accordance with the correct type and model as specified on the data plate and complies with the site requirements.

The IDFBDX-EBM models use the EBM - Papst high performance centrifugal fan modules.

Single inlet, direct drive, 2D centrifugal impeller with circumferential diffuser mounted on an electronically commutated external-rotor motor with integrated electronics. Backward curved impeller blades, inlet nozzle made of galvanised sheet steel with pressure relief. Complete unit statically and dynamically balanced in two planes according to DIN / ISO 1940 and to balancing quality G 6.3. EC external-rotor motor with maintenance-free ball bearings and permanent lubrication. A wide voltage input 1~200-277V, 50/60 Hz respectively 3~380-480V, 50/60Hz. Unit can be operated on all standard Electricity Board networks at identical air performance. Optimised motor technology, soft start, integrated current limitation, connection via brought-out variable cable connector (motor size 084) or via easy-to-mount and robust integrated terminal box made of aluminium with spring loaded terminals (motor sizes 112, 150 and 200). Extremely compact electronics, with adjustable PID controller (motor sizes 112, 150 and 200); meets all necessary EMC directives and all requirements as to current reverse transfer. No complicated installation with shielded cables required, very low-noise commutation logic, 100% controllability. Motors with an output of 750 W or higher have the RS485/MODBUS RTU interface. If structure-borne noise needs to be decoupled, any such action has to be taken by the customer.

\* To be confirmed

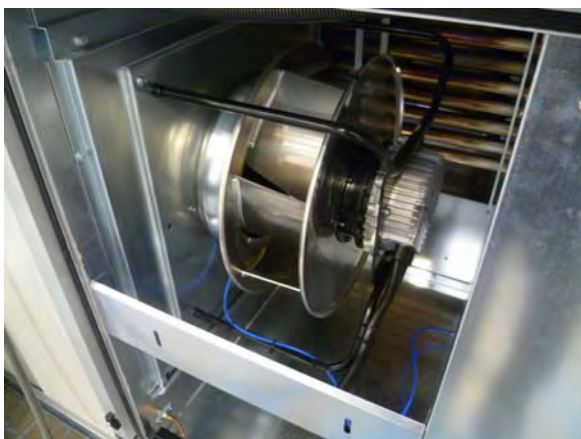

The fan assembly is plated mounted, which is on a slide rail within the unit for easy removal should it be require.

The photo below shows the fan assembly within the unit at various stages of assembly.



EBM fan arrangement in IDF2—IDF3

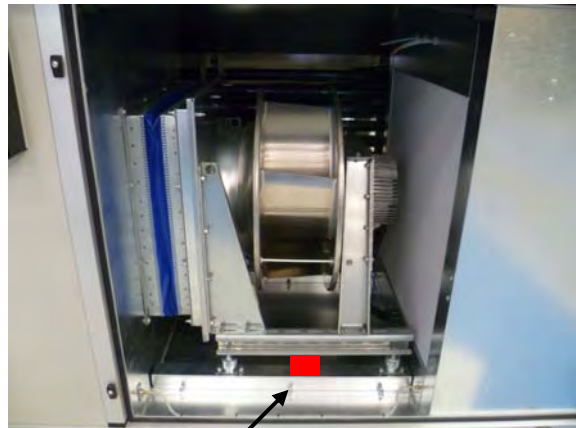

retaining strap

EBM fan arrangement in IDF4.

### Important:

**Before the fan is started remove the fan retaining strap shown in red above, failure to remove the retaining strap may cause issue and invalidate any warranties.**

## 2. Technical Data

Table 1.

Model No.	Power supply TP&N 415v. 50 Hz	Motor power kW	Motor Power @ duty kW	Motor Current @ Duty AMPS	Air volume m <sup>3</sup> /sec	DX cooling capacity kW	No. of stages	DX heating capacity kW	Gas heating input kW	Gas heating output kW	Gas rate m <sup>3</sup> /hr	Weight kg
IDF2BDX90 (CS1)*	400.3.50	1.78	1.63	2.47	1.41	28.0	2	28.0	53.3	49.0	5.63	905
IDF2BDX120 (CS1)*	400.3.50	2.83	2.02	3.07	1.89	38.0	2	44.8	53.3	49.0	5.63	905
IDF2BDX150 (CS1)*	400.3.50	2.83	2.55	3.93	2.40	44.0	2	54.0	53.3	49.0	5.63	905
IDF3BDX180 (CS2)*	400.3.50	4.7	2.86	4.33	2.77	52.0	3	60.8	78.8	72.0	8.33	1260
IDF3BDX200 (CS2)*	400.3.50	4.7	3.24	4.94	3.11	63.0	3	76.4	78.8	72.0	8.33	1260
IDF4BDX240 (CS2)*	400.3.50	6.14	4.03	6.37	3.80	66.0	3	81.0	78.8	72.0	8.33	1365

Model No.	Pressure Differential across EBM fan Pa	K Factor
IDF2BDX90	329	280
IDF2BDX120	591	280
IDF2BDX150	952	280
IDF3BDX180	821	348
IDF3BDX200	1035	348
IDF4BDX240	976	438

To calculate the air flow from the pressure differential across the EBM fan

$$\text{Air Flow m}^3/\text{sec} = \frac{K \sqrt{\text{pressure differential Pa}}}{3600}$$

$$\text{pressure differential Pa} = \left( \frac{\text{Air Flow m}^3/\text{sec} \times 3600}{K} \right)^2$$

These calculations are to be used as a guide.

## 2. Technical Data cont.

### Nomenclature

	IDF	2	B	DX	90	S1	I/T/C	– EBM
Indirect fired								
Airflow 2/3/4								
Heat exchanger (Benson)								
Heating/cooling coil								
Size 90/120/150/180/200/240								
S1= without dampers, S2= with dampers								
I= Inline, T= Trane, C=Compac <i>Note: If this is blank, it denotes standard configuration.</i>								
Fan Type								

## 2. Technical Data cont.

**Diagram 1. Overall dimensions**

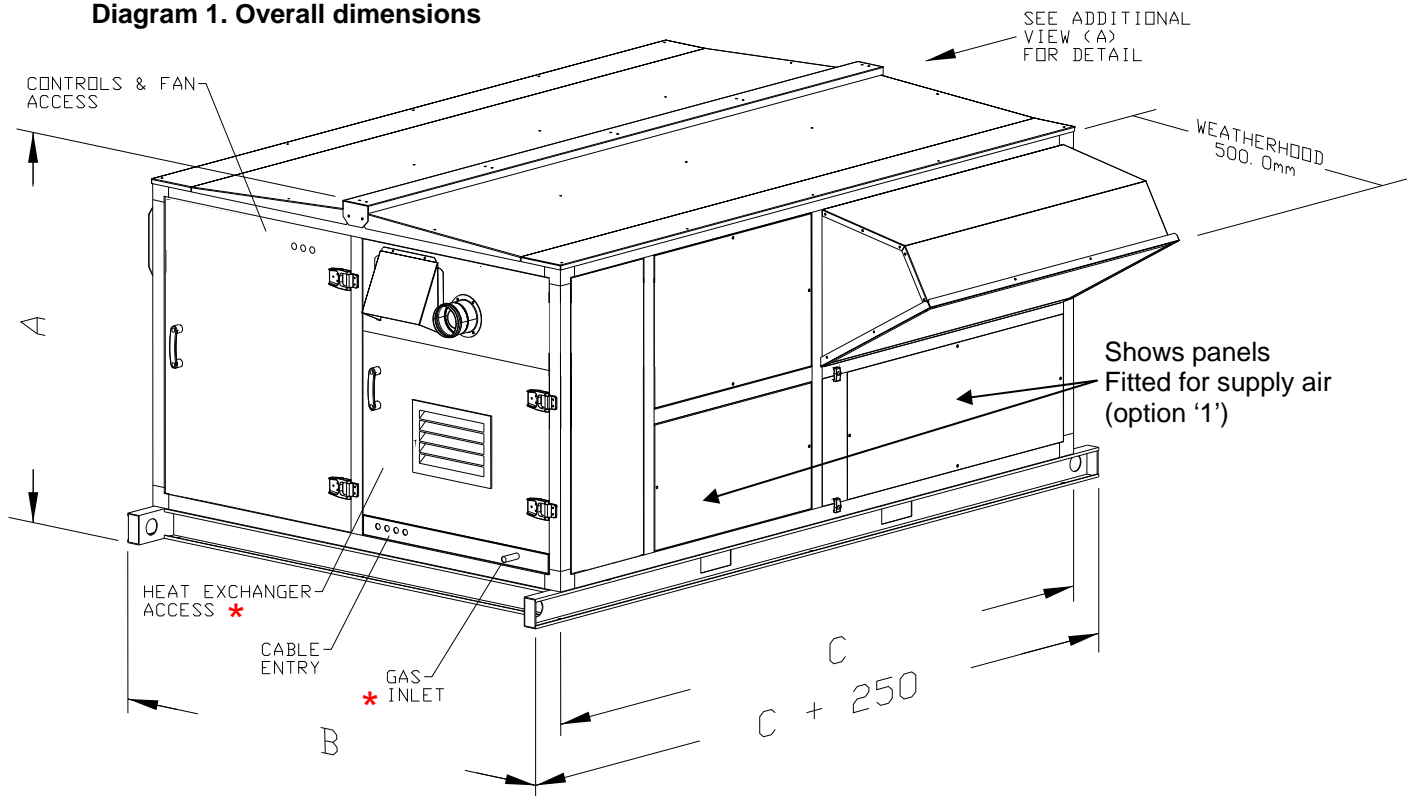

\* Applies if optional heat exchanger fitted.

**Table 2**

	<b>A</b>	<b>B</b>	<b>C</b>
<b>CS1</b>	1285	1800	2552
<b>CS2</b>	1352	2337	3180
<b>CS3</b>	1352	2337	3460

**Diagram 2. Additional view on 'A'**

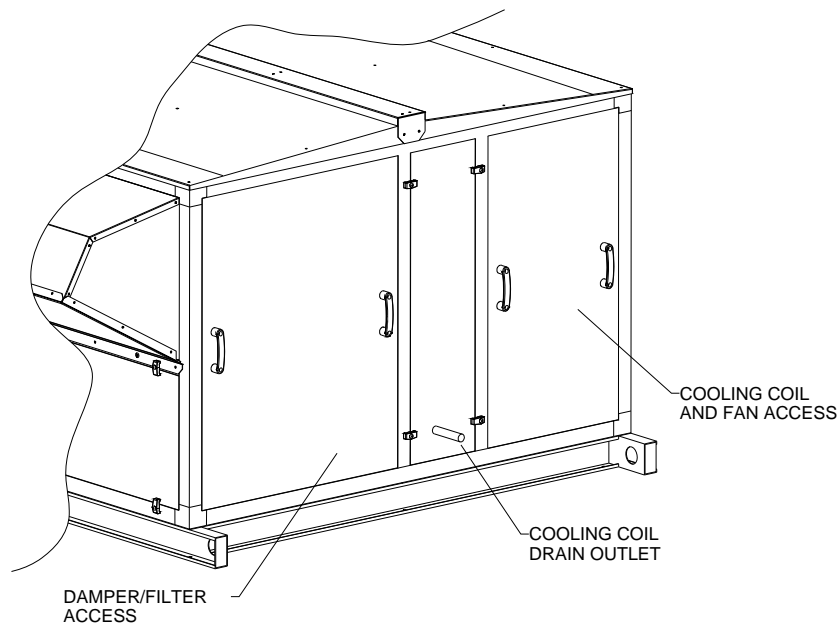

## 2. Technical Data cont.

**Diagram 3. Base frame dimensions**

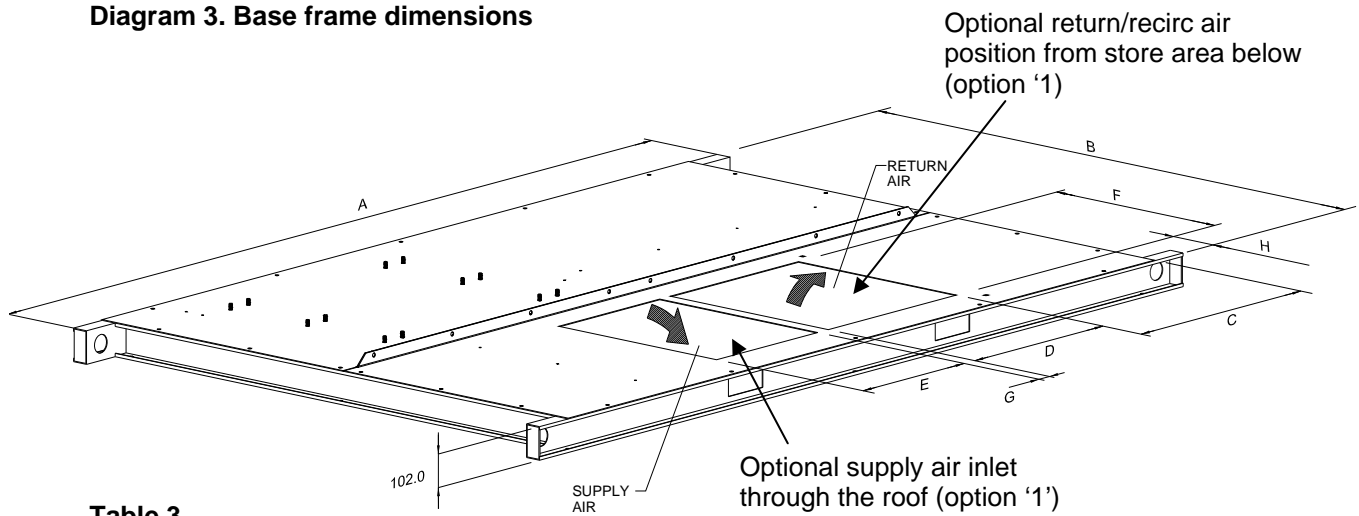

**Table 3**

	A	B	C	D	E	F	G	H
<b>CS1</b>	2802	1800	695	558	440	610	46	148
<b>CS2</b>	3430	2337	615	840	544	887	70	148
<b>CS3</b>	3710	2337	895	840	544	887	70	148

**Diagram 4. Duct flange dimensions**

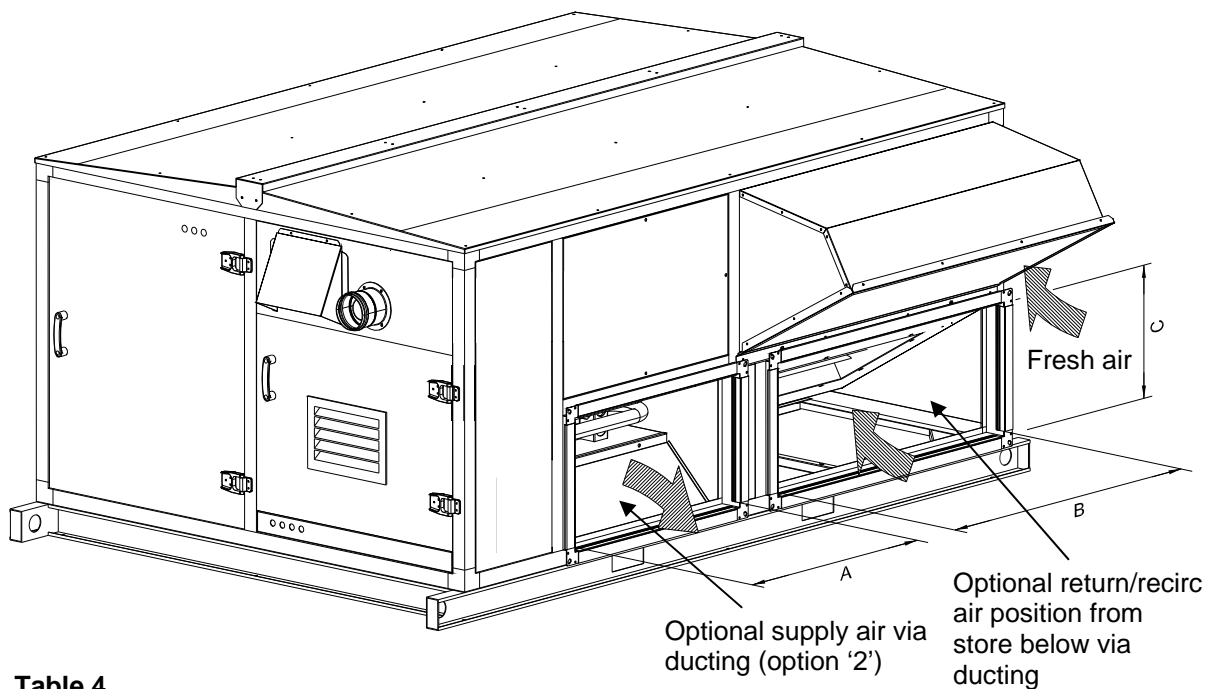
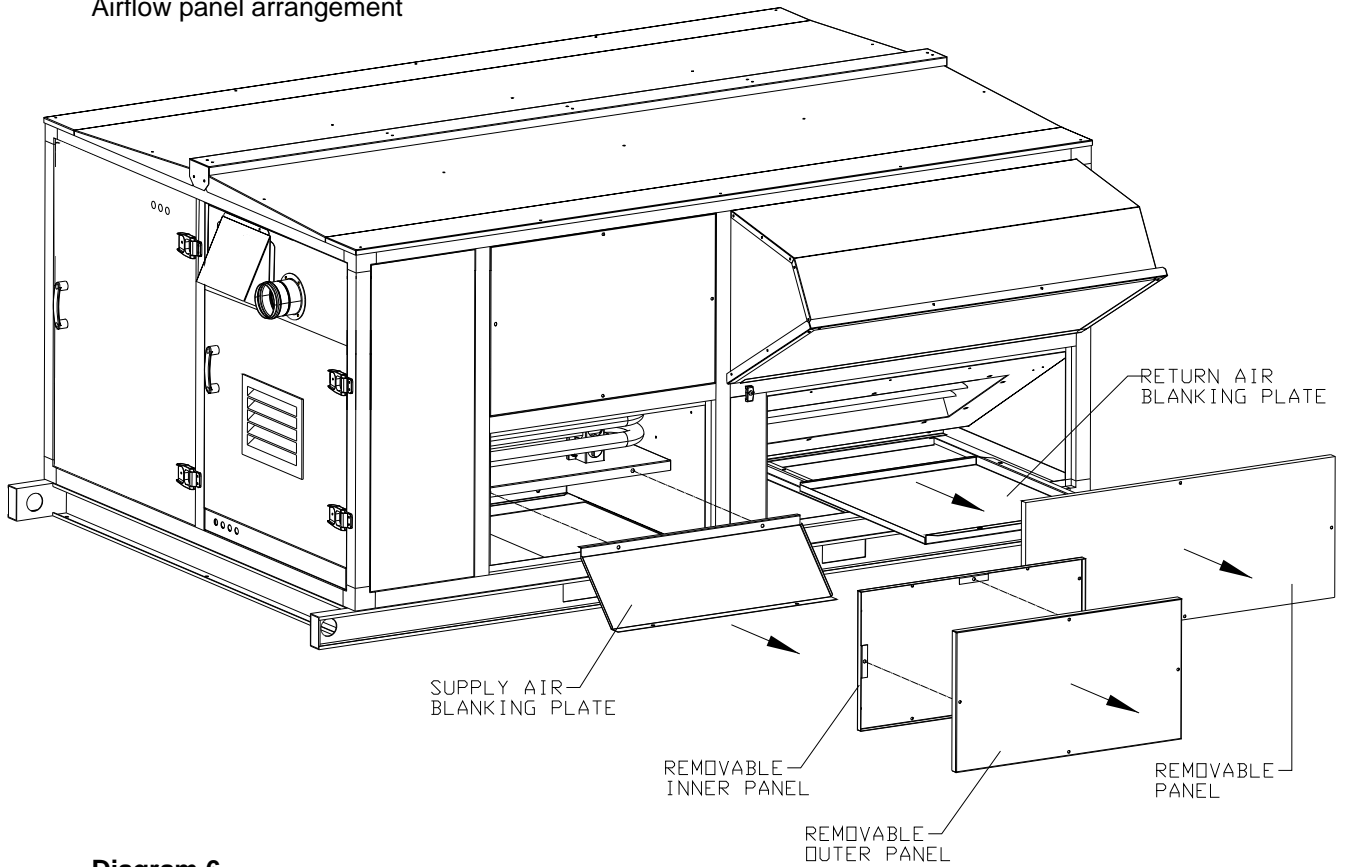

**Table 4**

	A	B	C
<b>CS1</b>	780	1070	475
<b>CS2</b>	1235	1245	545
<b>CS3</b>	1235	1525	545

## 2. Technical Data cont.

**Diagram 5.**  
Airflow panel arrangement



**Diagram 6.**  
Heat exchanger removal

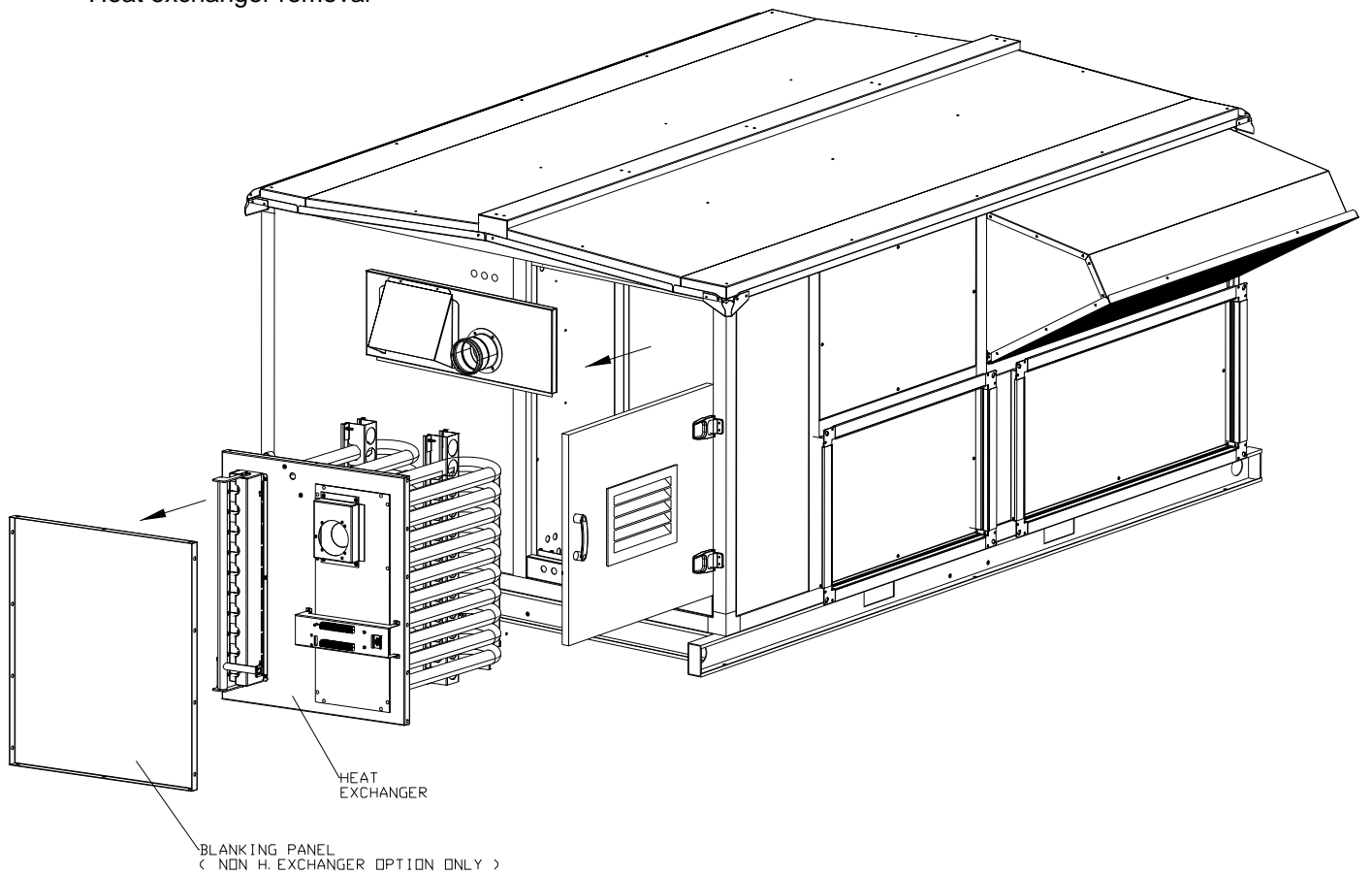

## 2. Technical Data cont.

### Alternative supply/return air and weatherhood configurations

CONFIGURATION 2

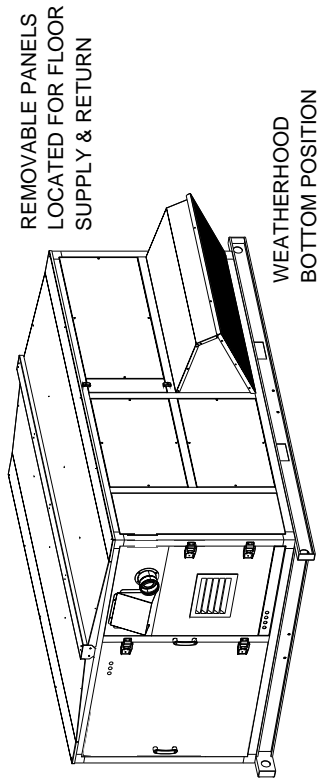

CONFIGURATION 4

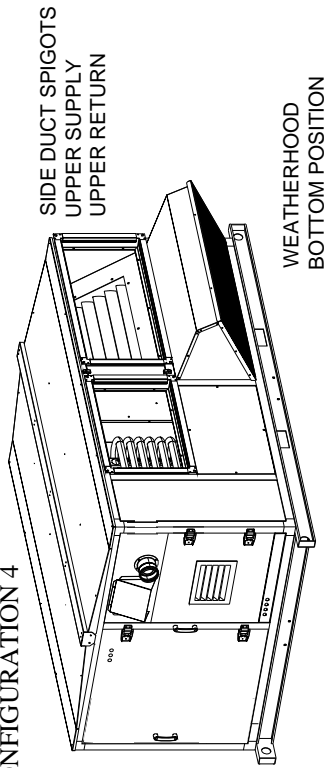

CONFIGURATION 6

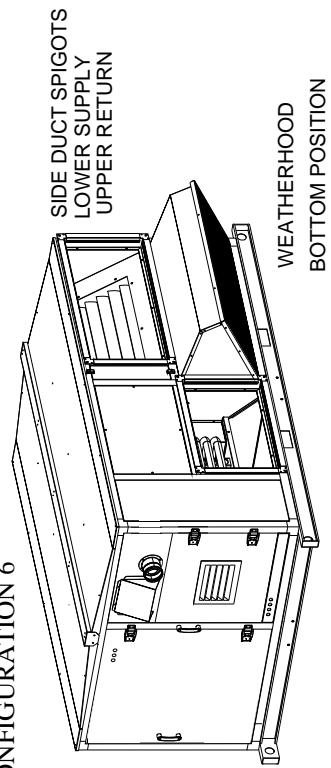

CONFIGURATION 1

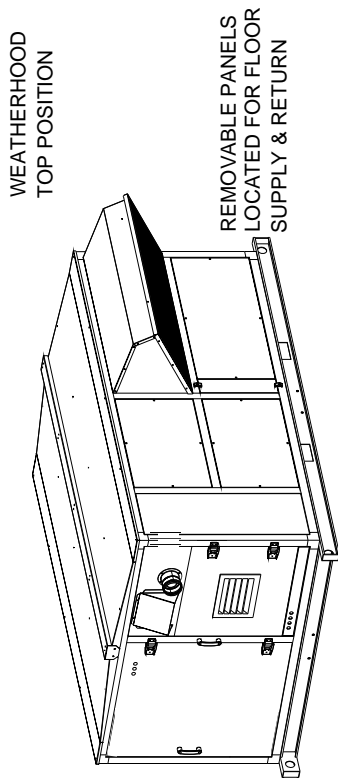

CONFIGURATION 3

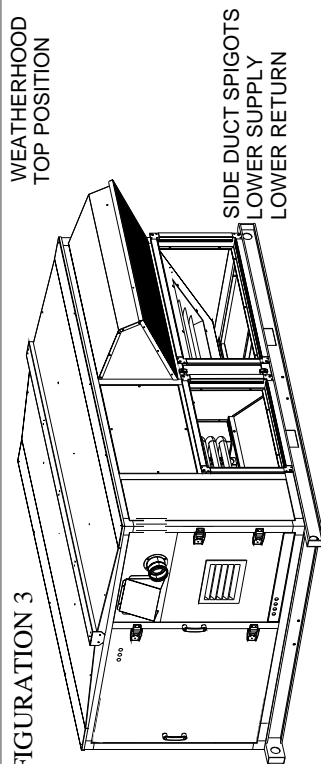

CONFIGURATION 5

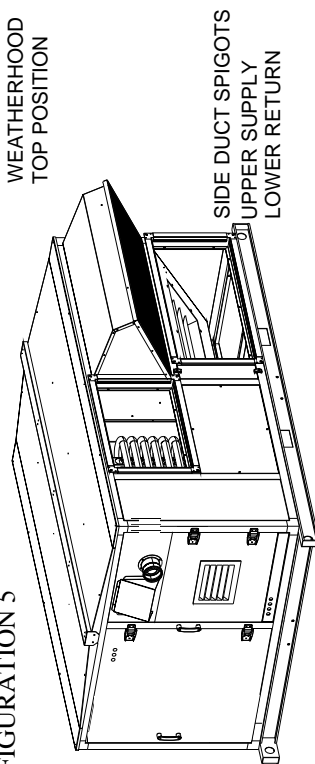

## 2. Technical Data cont.

### IDF2BDX 120/150 S1/S2 T –EBM

**RH ACCESS SIDE ELEVATION**

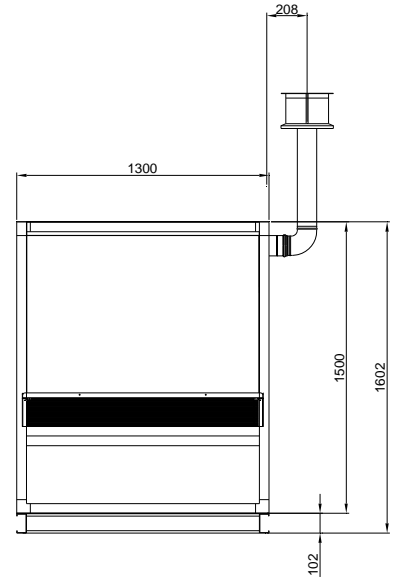
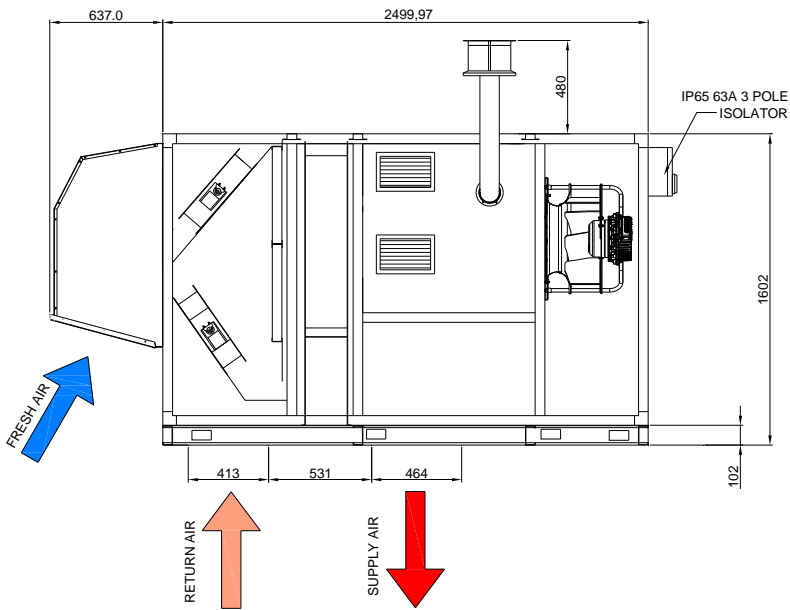

**END VIEW ON FRESH AIR**

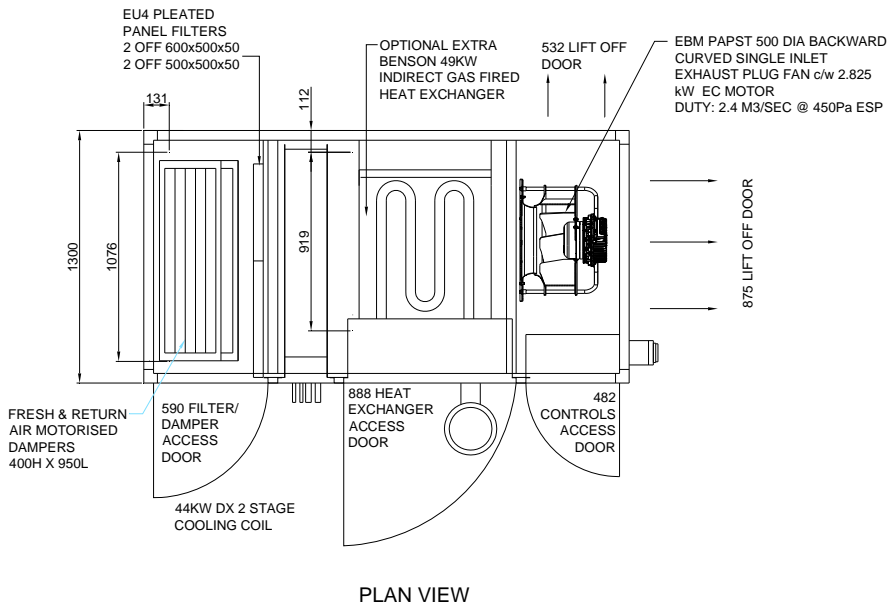

**PLAN VIEW**

## 2. Technical Data cont.

### IDF2BDX 90/120/150 S1/S2 I/C –EBM

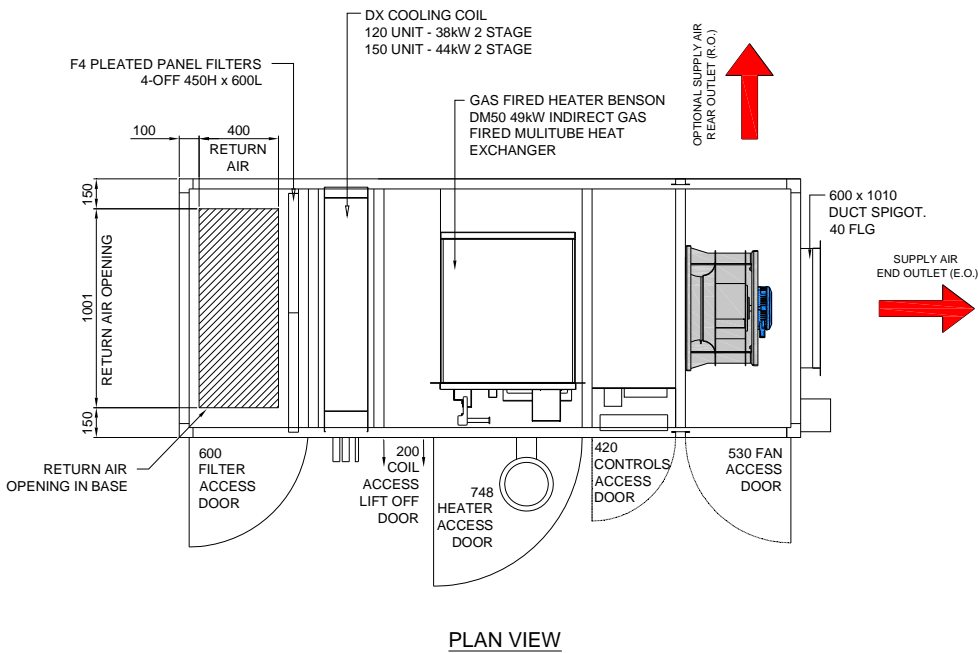
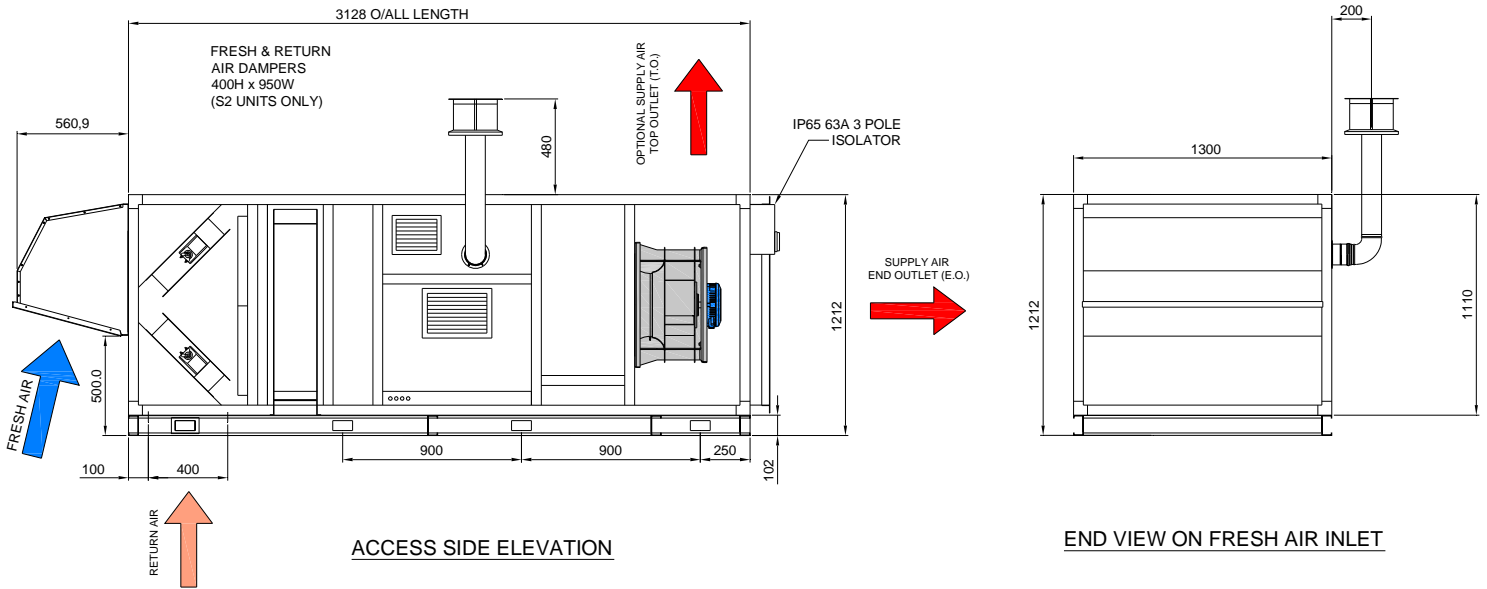

## 3. Installation Details

### Handling The Equipment

#### Base Frame

IDF heaters are supplied with a channel base frame, which incorporates cut-outs suitable for lifting purposes.

Ensure that the structural elements which will be used to support the appliance are adequate to carry the weight of the appliance and its ancillary components i.e. the ductwork system.

Ensure that the unit is installed on a level plane, and that the surface onto which it is installed is vibration free.

The heater must be lifted into position using a suitably sized crane, with lifting bars or lifting straps threaded through the lifting points. When using lifting straps sling spreaders must be used to provide clearance between the appliance and the slings.

Each heater should be positioned onto the existing steel frame, allowing a minimum 600mm clearance on non-access sides and 850 mm on the access side for removal of heat exchangers. (See diagram 8)

When installing external weatherproof appliances ensure that any part of the installation that may be installed outdoors will not jeopardise the integrity of the premises security.

The unit must be fastened securely to support frame work.

For heaters fitting onto existing roof curbs, an air tight seal between the base and the curb must be made.

**Sling spreaders must be used to provide clearance between the appliance and the slings. (See diagram 7)**

***Note: It is the responsibility of the installer to ensure that safe lifting practices are followed on site, and to note that the detail provided in these instructions is for guidance only.***

### Duct Connections

Nordair Niche IDF heaters are designed to be used in conjunction with air intake and air distribution ducting. A positive seal must be made between ductwork and the connection onto the appliance. All ductwork must be supported independently and not supported from the heater casing.

Flexible duct connections to the appliance are not required as the fan outlet is fitted with a flexible connection and is isolated from the casing via anti-vibration mounts.

Care should be taken when designing ducting systems especially with regard to the selection of fittings which will be installed adjacent to the appliance, abrupt elbows fitted directly on to the appliance can cause turbulence and create uneven air flows across the heat exchanger, resulting in hot spots and nuisance shut down of the burner due to regional overheating in the vicinity of the limit stat protection devices. Unnecessary pressure loss and noise generation may also be caused by badly designed duct systems.

Ducting should be manufactured from materials suitable for the purpose also taking into account the integrity of the building security.

Externally routed ducting should be thermally insulated and protected with a waterproof membrane.

### 3. Installation Details

**Diagram 8.  
Slinging**

**Note:** It is the responsibility of the installer to ensure that safe lifting practices are followed on site, and to note that the detail provided in these instructions is for guidance only.

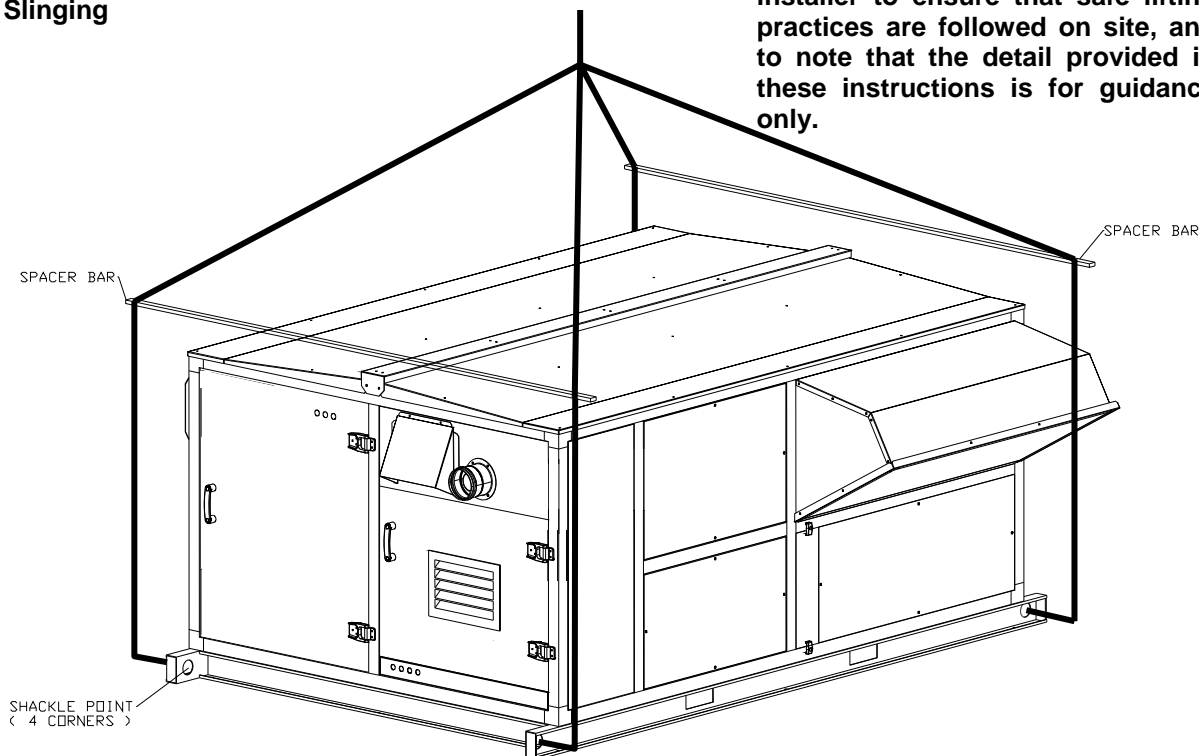

**Diagram 9.  
Clearances**

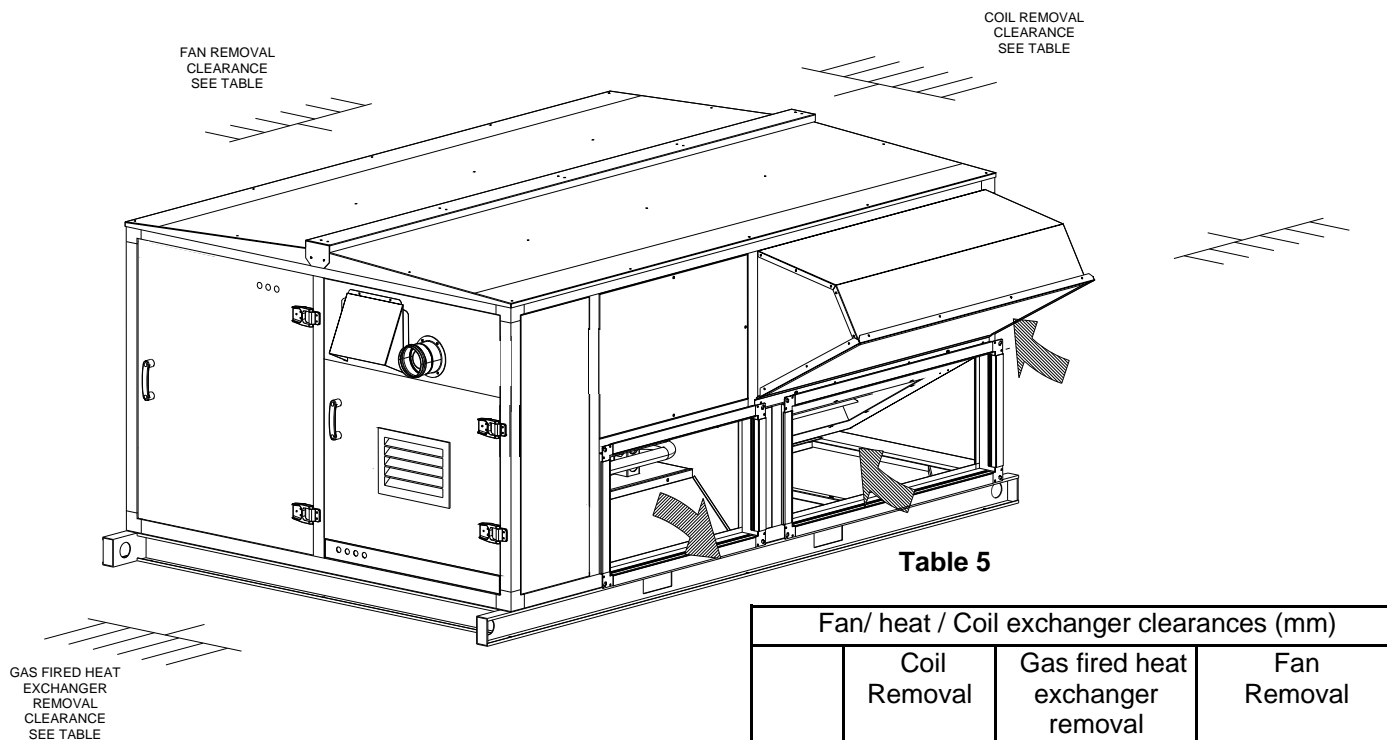

Fan/ heat / Coil exchanger clearances (mm)			
	Coil Removal	Gas fired heat exchanger removal	Fan Removal
CS1*	1500	1000	1500
CS2*	1700	1700	1700
CS3*	2000	1700	2000

\* See section 2 table 1. for model case sizes

## 4. DX Coil Information

### DX COILS

#### General description

DX coils comprise a matrix of copper tubes supported in tube end plates and associated casing work. The tube matrix carries thin continuous fins, regularly spaced, at right angles to the tube matrix.

The tubes are fed via headers which distribute the fluid between a number of parallel circuits to give the optimum tube velocity. The flow from the parallel circuits rejoins in the return header. The flow to DX evaporator coils is via distributor and capillary tubes to ensure even distribution.

The fin array is designed to provide an enlarged air side surface and to optimise heat transfer for the design air conditions, whilst minimising the resultant air side pressure drop.

All coil blocks are tested to 22-bar air under water, dried, vacuum tested and charged with dry nitrogen.

F Gas certificate of engineers must only be used for the installation, service, maintenance or commissioning of refrigeration air conditioning and heat pump systems containing or designed to contain HFC refrigerant.

#### Refrigerant coils

Evaporator coils are supplied with one or more liquid refrigerant distributors connected via capillary tubes to the coil circuitry. These are of equal length for correct refrigerant distribution. Care should be taken to avoid kinking the tubes.

Refrigerant coils are generally supplied with sealed caps, and the coil positively charged with dry Nitrogen. The connections should be cut or sweated off when ready for installation. Capillary or compression fittings should be fitted according to manufacturer's instructions.

Care should be taken to avoid the introduction of foreign matter or moisture into the system when piping up, as this may have an adverse effect on the longevity and performance of the system.

### Maintenance

Preventative maintenance is generally required to ensure that the coils are maintained in a clean condition. This has three purposes:

1. Ensures that there is no marked increase in air side pressure drop.
2. Ensures that there is no significant impairment in air side heat transfer capability.
3. Ensures that drainage from wet coils is not impaired over time.

Coils are virtually maintenance free, but in the event of build up of atmospheric dust or fluff on the fin surface, can be removed by vacuum or air blast, taking care that all loosened debris is removed and not carried into the distribution ductwork. In the event of fins being pressed in, relieve with a thin blade. Minor fin-damage has little or no effect on coil performance.

It is normal when checking for drainage to ensure that this occurs when the system is running, in addition to static tests.

### Cleaning

Coil drain pans extend beneath the fin block return bends and manifolds so as to catch all moisture

condensing on the cold surfaces in the cooling cycle. Drain pans should be inspected and cleaned on a regular basis so as to prevent the build up of debris and/or mould. The degree of build up is specific to each installation and will depend largely on the ambient contamination and class of air filtration.

It is recommended that the drain pan be cleaned on a 3 monthly basis, at least initially, following a procedure broadly in line with that described below.

The drain trap to the drain pan should be removed to allow free drainage of cleaning fluid and a bucket or other receptacle placed below the drain point protruding through the panel of the AHU. Access to the coil drain pan can be gained from either the leaving or entering air face or from the ends of the coil after removing the necessary AHU panel. Water or cleaning fluid can then be poured into the drain pan or alternatively a steam spray can be used. Take care not to flood the drain pan during filling. Most proprietary cleaning fluids are suitable for the galvanized steel drain pan though

## 4. DX Coil Information cont.

these should be non-acidic. Foaming detergents are best for detaching debris but detergents should be rinsed from the pan after use to prevent them contaminating the air stream.

After cleaning the drain trap should be refitted and primed with water before putting back into operation.

### Recovery

There is no special recovery equipment for the coils.

In the event of significant failure, the complete coil should be removed for maintenance purposes.

The most common type of failure to occur is a tube leak. Whilst it is sometimes practical to carry out repairs on site, removal of the complete coil is recommended in order to ensure subsequent integrity if repaired, or for replacement.

In the event of coil removal being necessary, the following procedure should be followed.

Refer to condenser manufactures instructions on the required procedure.

F Gas certificate of engineers must only be used for the installation, service, maintenance or commissioning of refrigeration air conditioning and heat pump systems containing or designed to contain HFC refrigerant.

Disconnect connections.

Support coil as required for subsequent dismounting, and unbolt casework flanges.

Remove coil.

### Corrective maintenance

Copper coil tubes between coil block and headers may be bent or fractured if excessive strain is put on headers.

During installation or removal coils should be lifted by means of the casing and **NOT** the headers or connections.

Casework should be securely fixed prior to pipe work flanges being made up.

In order for work to be carried out on the air side faces of the coil or within the ductwork, the system fan should be isolated.

## 5. Gas & Electrical Connections

### Gas

Connection to gas service may only be carried out by appropriately qualified persons. The gas installation must comply with the rules in force using materials appropriate for gas installations.

Check that the gas category is in accordance with the data described on the air heater data badge.

An adequate gas supply sized to provide the dynamic pressure for the volume required for the air heater/s is essential to maintain the nominal heat input. Other gas fired plant using the same gas service must also be taken into account.

A 90° action, positive isolating ball valve must be fitted adjacent to the appliance, fitted in a manner to facilitate access to the burners for servicing purposes.

Ensure that the gas service has been tested and purged in accordance with prescribed practice prior to commissioning and setting the appliance into service.

Ensure that the gas supply is filtered and it is free of swarf or debris before connecting to the appliance.

### Electrical

The electrical installation may only be carried out by appropriately qualified persons observing the rules in force.

Check the electrical specification is in accordance with the specification on the appliance data plate. A unique appliance wiring diagram is supplied as a separate document attached to this one, plus an additional copy attached to the unit.

The unit must be earthed.

Ensure that power will be supplied at all times to the unit, even when it's control is switched in the "HEAT OFF" mode. This is necessary to ensure that the air circulating fan can operate independently of the heating control.

A separate lockable isolator for each air heater must be provided adjacent to the appliance and within the sight of any person working on the appliance. The isolator must have a contact separation of at least 3.0mm on all poles. The

isolator should be of the key operable type to prevent vandalism and to prevent switching by others thus placing anyone working on the appliance at a safety risk.

Where controls are not provided by Nordair Niche, then ancillary controls must be installed to provide timed heat cycles, room comfort temperature levels, frost protection, override of air circulation etc.

*Note: When working on the appliance electricity to the appliance should not be switched OFF before the room thermostat has been switched OFF, the gas valve has closed and the air circulation fan has stopped.*

All cable and gas service entry points to outdoor appliances must be sealed to prevent ingress of water.

If it is necessary to change the rotation of blower to match the direction indicated on blower housing then three phase motors can be altered by reversing two phases of the supply to the motor.

On units fitted with centrifugal forward curved fans, the speed setting for static pressure imposed by the air distribution system will govern the motor loading. The units are manufactured for the duty specified on the data badge (Table 1).

Refer to section Drives general and adjustments for instructions on adjusting the fan speed and motor load factors.

After the electrical installation has been completed the appliance should be tested prior to the commissioning of the gas fired heat exchanger module(s).

*Note: Outdoor commissioning work on Nordair Niche appliances should not be undertaken during wet conditions, a second person should always be available to provide assistance in the event of an emergency.*

Check to ensure:

- Earth continuity
- Resistance to earth
- Phase supply to correct terminals
- Current rating and circuit breaker value

## 6. Commissioning & Testing

If the Nordair Niche IDF unit is fitted with indirect gas fired heat exchanger(s). The attached instructions must be read and understood prior to commencing work and must be followed for all commissioning and service operations.

*Note: Outdoor commissioning work on Nordair Niche appliances should not be undertaken during wet conditions, a second person should always be available to provide assistance in the event of an emergency.*

Only persons formally qualified to work on gas fired apparatus may carry out commissioning and testing.

### Electrical check

After completion of the installation and before switching on the electrical supply to the appliance, a qualified electrician must carry out a preliminary check. The following must be checked:

- Check to ensure that electrical cables/ wiring do not touch the hot combustion collector box.
- Check that all wiring is connected in accordance with the appliance circuit diagram.
- Be certain that the correct fuse value and cable size has been provided.
- Check to ensure that the appliance is earthed by conducting an earth continuity test. Connect a test meter, one lead to the appliance earth terminal and the other to the mains incoming earth point at the electrical isolator. A resistance reading of 1,0 ohm or less must be indicated. If a higher reading is obtained, check all cable connections to ensure adequate security and cleanliness. If problem still exists, it may be necessary to consult the electricity supply undertaking.
- Carry out a polarity test. Connect one lead of a suitable AC voltmeter to earth and connect the other lead to the live supply terminal (L) at the air heater. Switch ON the power to the air heater and check for correct voltage. The same result should be obtained by connecting the test leads between live and neutral. Connect the voltmeter test leads to N and E. A reading of  $\pm$  0V should be obtained. If these tests do not conform with the above, there is a fault which must be rectified before proceeding further with the commissioning.

- Check that all sensors have been fitted in accordance with the supplied wiring diagram.
- Avoid location in draughty areas or where it may be influenced by heat sources e.g, the sun, process plant, etc. The thermostat or temperature sensor should be mounted on a vibration free surface and mounted about 1.5 metres above floor level.

### Gas connection

The whole of the gas service installation including the meter must be inspected, tested for soundness and purged in.

*Caution: Never use a flame for checking gas soundness.*

## 6. Commissioning & Testing cont.

### 6.1.0 Compliance notices

The Benson Variante range of ducted warm air heating modules detailed herewith are manufactured by Benson Heating within a strictly controlled environment within the parameters of ISO9001.

These instructions are only valid if the following country code is on the appliance **GB. IE**. If this code is not present on the appliance, it is necessary to refer to the technical instructions which will provide the necessary information concerning the modification of the appliance to the conditions of use for the country.

The Benson Variante Range has been independently tested and assessed, and has been found to meet the Essential Requirements of the following European Directives.

Gas Appliance Directive (90 / 396 / EEC)  
Machinery Directive (2006/42/EC)  
Low Voltage Directive (2006/95/EC)  
Electromagnetic Compatibility Directive (2004/108/EC)62  
Product Liability Directive (85/374/EEC)

The manufacturer has taken reasonable and practical steps to ensure that Benson Variante Range of Heaters are safe and without risk when properly used. These heaters should therefore only be used in the manner and purpose for which they were intended, and in accordance with the recommendations detailed herewith.

The heaters have been designed, manufactured, assembled, inspected, and tested, with safety and quality in mind, there are certain basic precautions which the installer and user should be aware of, and they are strongly advised to read the appropriate sections of the information pack accompanying the heater, prior to installation or use.

Benson Heating supports all new products being supplied to their customers with a comprehensive information pack; this clearly defines mandatory instructions for the safe installation, use, and maintenance, of the appliance (s).

Where proprietary items are incorporated into Benson Heating products, detailed information and instructions are also provided as part of the information pack.

It is the responsibility of the installer, owner, user, or hirer, of such products supplied by Benson Heating, to ensure that they are familiar with the appropriate information manuals, supplied by the

manufacturer, and that they are suitably aware of the purpose of the manuals and the safety instructions. In addition, operators must be suitably trained in the use of the appliance so as to ensure its continued safe and efficient use.

Benson Heating has a commitment to continuous improvement, and therefore reserves the right to amend or change the specification of the Variante Heater range subject to agreement from The Notified Body.

Contained within the text of the manual, the words '**Caution**' and '**Warning**' are used to highlight certain points.

**Caution** is used when failure to follow or implement the instruction(s) can lead to premature failure or damage to the heater or its component parts.

**Warning** is used when failure to heed or implement the instruction(s) can lead to not only component damage, but also to a hazardous situation being created where there is a risk of personal injury.

The Benson Variante range of heaters conform to the following European Harmonised Standards.

BS EN 1020 Requirements for non domestic gas fired forced convection air heaters for space heating incorporating a fan to assist transportation of combustion air and / or combustion products.

BS EN - ISO 12100-1 & 12100-2  
Safety of Machinery - Basic Concepts,  
General Principles for Design Part 1 & 2

BS EN 60204 - Part 1  
Safety of Machinery - Electrical Equipment

for Machines Specification for General Requirements

BS EN 60335 - Part 1  
Safety of Household and Similar Electrical Appliances General Requirements

BS EN 55014  
Limits and methods of measurement of radio disturbance characteristics of electrical motor-operated and thermal appliances for household and similar purposes, electrical tools and similar electric apparatus

BS EN 50165  
Electrical Equipment of non-electric heating appliances for household and similar purposes,

## 6. Commissioning & Testing cont.

safety requirements.

The Benson Variante range of gas unit heaters meet with the governments criteria in respect of the Enhanced Capital Allowance Scheme.

### 6.1.1 Certificates of conformity

Declarations and Certificates are available upon request from the Quality Control Department at Benson Heating.

### 6.1.2 General product information

Each model size can be used as a Duct Module (DM), are suitable for operation on natural gas (G20) or LPG Propane (G31 - On/Off ONLY)

The Model Range is made up as follows:

Model No	DM50	DM72
Output kW	49.0	72.0

Variante heaters have been approved for alternative flue discharge arrangements These are detailed in following pages .

#### Heat Exchanger

Manufactured from aluminised / stainless\* dimpled steel tube.

#### **WARNING** **(SEE FLUE INSTALLATION PAGE 20+21)**

#### Burner

The induced draught multi burner assembly is manufactured from aluzinc coated steel and mounted to a common steel manifold which can be easily withdrawn through the burner access compartment.

#### Burner Control

The heaters are fitted with automatic ignition for all models within the range.

#### Exhaust Fan

Combustion gases are evacuated to atmosphere via an in built power flue venter fan which is safety interlocked to the gas valve via an air pressure proving device.

#### Notes:

Neither asbestos nor soft soldered joints are used in the construction or manufacture of the Benson range of Heaters.

The materials selected for use can withstand the mechanical, chemical, and thermal stresses which they will be subject to during foreseen normal use when installed in accordance with the manufacturers recommendations.

### 6.1.3 General Requirements

#### Caution

Before installation, check that the local distribution conditions, nature of gas and pressure, and the current state adjustment of the appliance are compatible.

#### Warning

Unauthorised modifications to the appliance, or departure from the manufacturers guidance on intended use or installation contrary to the manufacturers recommendations may constitute a hazard.

#### Note:

To ignore the **warning** and **caution** notices, and to ignore the advice from the manufacturer on installation, commissioning, servicing, or use, will jeopardise any applicable warranty, moreover, such a situation could also compromise the safe and efficient running of the appliance itself, and thereby constitute a hazard.

This appliance must be installed by a competent person and in accordance with European, National, and Local criteria, including any relevant standards, codes of practice the requirements of the current building Regulations (and in particular parts J & L), Health and safety regulations IEE regulations and any requirements of the local Authority, Fire Officer or insurers.

Relevant standards may include BS6230, BS6891 and BS5588 parts 2 and 3.

Prior to installation the following points should be considered;

- The position of the heater for the optimum efficient distribution and circulation of warm air.
- The position of the heater relative to the route of the flue.
- The position of the heater relative to the supply of gas.
- The position of the heater relative to the electrical services, wiring routes, and if appropriate, any additional controls.

## 6. Commissioning & Testing cont.

- e) The position of the heater relative to the supply of fresh air.
- f) The position of the heater relative to potential stratification/circulation problems, which generally occur at higher levels and which may be overcome through the provision of a suitable de-stratification unit.
- g) The position of the heater relative to service and maintenance requirements.

### Caution

The heater **must not** be installed within an area where the conditions are unsuitable, e.g. where the atmosphere is highly corrosive, has a high degree of salinity, or where high wind velocities may affect burner operation. Suitable protection should be provided for the appliance when it is located in a position where it may be susceptible to external mechanical damage from; for example, fork lift trucks, overhead cranes etc.

### 6.1.4 Warranty

The heater is supplied with a 1 year parts and labour warranty and a further year on all parts excluding consumables.

In addition to this there is also a 10 year time related warranty on the combustion chamber.

The warranty commences from the date of dispatch from the manufacturer, and is subject to the terms detailed within the Benson Heating 'conditions of business'.

### Note (i)

The warranty may be invalidated if -

- a) The installation is not in accordance with the general requirements of this manual.
- b) The flue arrangement and air supply for the heater are not in accordance with the manufacturers recommendations, codes of practice, or similar standards.
- c) Air flow through the heater is not in accordance with the manufacturers technical specifications.
- d) Internal wiring on the heater has been tampered with or unauthorised service repairs undertaken.
- e) The main electrical supply input to the heater has been interrupted during the heating mode.
- f) The heater has been subject to and affected by the ingress of water in any form.
- g) The heater is not operated at the rating(s) laid down in the manufacturers technical specifications.
- h) The heater has not been operated or used within the normal scope of its intended application.

- i) The manufacturer's recommended minimum service requirements have not been complied with.

### Note (ii)

All warranty claims must contain the following information to enable processing to take place;

- (1) Heater model.
- (2) Heater serial number.
- (3) Order reference/date of order, together with full installation details (name and address).
- (4) Details or symptoms of fault.
- (5) Installers name and address.

Faulty parts must be returned to the Benson Heating Spares Department, the address of which is provided on the cover of this manual. Any such parts will undergo inspection to verify the claim. Replacement parts supplied prior to this may be charged, and a credit supplied upon subsequent validation of the warranty claim.

Consumable items are specifically not included within the scope of the warranty.

### Note (iii)

Notification is required immediately a fault is suspected.

The manufacturer will not accept responsibility for any additional damage that has been caused, expense incurred, or consequential loss resulting from any failure of the heater(s).

### 6.2.0 Flue Installation.

An integral flue spigot is fitted to all DM/DMV/DMVE heaters thereby allowing the flue to connect directly to the heater. These spigot connections can be either side or top outlet (specified at time of order).

The design of the flue must ensure that it can be disconnected to allow for cleaning and servicing.

All joints should be sealed between the sections.

### Warning

It is essential that the products of combustion are flued to the outside of the building.

Each heater must have its own separate flue, with a flue diameter of not less than is detailed on **page 34** within this manual.

The flue assembly must comply with all the relevant regulations regarding height and materials, and must terminate with an approved flue terminal.

Care should be taken to ensure that the flue terminal is not situated in a high pressure area,

## 6. Commissioning & Testing cont.

the proximity of buildings and other obstacles which will influence this must be taken into account, preferably at the design stage.

All DM/DMV/DMVE heaters are equipped with a built in flue venter fan which prevents the re-circulation of combustion products, consequently an external draught diverter, barometric damper, or anti spillage system must not be installed.

**Horizontal flue installations: Distance from heater connection to terminal must not exceed the following length-**

<b>DM50</b>	<b>6 Metres</b>
<b>DM72</b>	<b>8 Metres</b>

Each 90° bend corresponds to 1Mtr of flue length.

Each 45° bend corresponds to 0.8 Mtr of flue length.

Flue pipe should be supported at intervals not exceeding 1.8 Mtrs.

In order to provide adequate natural draught, the minimum length of horizontal flue must not be less than 1Mtr.

For vertical flue installations the flue should rise vertically where possible bends should not exceed 45° and the number of bends should be kept to a minimum.

**Vertical flue installations: Distance from heater connection to terminal must not exceed 10 Metres.**

The temperature of the combustion products can be as high as 170°C and therefore tend to rise naturally within the flue. Unnecessary bends and restrictions should therefore be avoided.

Provision for the disconnection of the flue for servicing and inspection purposes must also be made.

The position of the flue and its terminal should be such that it does not impair the combustion process. It should terminate in an exposed position so as to allow the free escape of flue gases without risk of their re-entering the building through windows, ventilation ports etc.

**The following distances in mm's should be observed**

**200** below guttering or eaves.

**300** from corners or openings (windows doors etc) and from other horizontal terminals on same wall.

**1200** from a facing surface.

**1500** from another terminal vertically on the same wall.

**2000** from ground level.

The heaters must be connected to the flue system supplied by Benson Heating and be capable of withstanding the stresses and loadings associated with normal use.

When designing the flue system the prevention of the formation and entrapment of condensation must be a key consideration.

Horizontal flue should be fitted ensuring a slight gradient approx 2° towards the terminal.

Where condensation is unavoidable traps should be included to encourage the condensates to flow freely to a point from which they may be released, preferably into a gully.

The condensate pipe from the flue to the disposal point must be made from corrosion resistant pipe of not less than 25mm internal diameter.

If the flue passes through a wall, ceiling, or roof made from combustible material then it has to be sleeved so as to provide a minimum of a 25mm void between the exterior of the flue and the internal wall of the sleeve.

### **Caution**

It is imperative that the flue should be properly sealed where it passes through the roof, this can best be achieved by using the approved method of roof flashing plate and cravat.

### **Note**

It should be noted that claims made under warranty and attributed to the ingress of water may not be considered especially if an approved method of sealing has not been used, or if the design of the flue has not made provision for possible condensation problems.

It is also recommended that BS5854 and BS5440: parts 1 and 2 are used as a consultative document when considering flue requirements.

If terminating through a wall only use Benson approved horizontal terminals.

## 6. Commissioning & Testing cont.

### 6.2.1 Electrical Installation

All electrical wiring and connections must be in accordance with the relevant European, National, and Local regulations as well as to IEE Standards.

Ensure that the Electric and Gas supplies are turned off before any electrical work is carried out on the heater.

Also ensure that wiring cannot make contact with any metal surfaces liable to be subject to high temperatures, and where insulation of the wiring could be impaired as a result of such contact.

All Variante models must be earthed.

#### **Warning:**

**Ensure that the electrical supply is compatible to the heater.**

#### **ALL HEATERS HAVE A NEUTRAL LOCKOUT RESET**

#### **Caution**

The main electrical supply must not be switched off or disconnected as a method for stopping the heater, the exception to this is in the event of an emergency, or when the heater has been allowed to cool sufficiently to prevent any damage from being sustained to the heater or its controls (ie: during servicing).

Claims for damage will not be considered if they have resulted from incorrect wiring or the incorrect use of the heater.

Wiring diagrams are also detailed within this manual, (page 33, 34, 53-67.)

#### **Electrical panel**

#### **Warning**

Ensure that the mains isolator is turned **OFF** before undertaking any electrical work on the heater. Access to the electrical panel is gained by removing the access cover (where applicable).

#### **Warning**

Ensure that all connections are secure and that there are no loose strands which could bridge across the terminals.

#### **Note:**

When external controls operate to switch the heater **OFF**, power to the heater should remain

on to allow the fan to continue to operate sufficiently cool the heater thereby preventing damage to the heat exchanger.

#### **Fan/Limit Controls**

(Situated inside the access panel)

#### **Fan control**

The fan control switch features normally open 230V contacts, and is wired to control the live supply to the fan motor. When the circuit is made the fan will switch on. When the thermostat or time switch shuts down the burner, the fan will continue to run until the thermal switch has cooled sufficiently to prevent the residual heat from damaging the heater or its controls.

On start up the fan delay prevents air being circulated until the desired temperature is achieved.

#### **Limit control (Set at 110°C)**

A high temperature manual reset limit control. If this control needs resetting the cause should be determined and rectified immediately.

#### **Caution**

The power supply to the fan must not be interrupted, the only time when power supply can be disconnected or interrupted is during servicing or in emergencies.

If there is a requirement for the heater to be switched off over night then the gas valve circuit should be opened via a time switch, etc, as per the wiring instructions and diagrams supplied within section 6.0 of this manual.

### 6.2.2 Gas installation

As there have been recorded instances of the deposition of copper sulphide dust within the valves and orifices of gas appliances as a direct result of a reaction between the hydrogen sulphide contained in some natural gases and copper pipe we recommend that the heater(s) should not be connected to any natural gas pipe distribution system which utilizes copper pipework, including final connections. Instead steel pipework should be used throughout.

In the event that it is impractical to use steel pipework or where installers are obliged or insist on using elements of copper pipework within the installation then we strongly recommend that the gas supplier be consulted as specific conditions and requirements may be necessary.

The Variante range of heaters are all

## 6. Commissioning & Testing cont.

manufactured and pre set for use with Natural/lpg Gas, and all feature 1/2" or 3/4" BSP connections. Prior to installation the supply characteristics (gas type and pressure) must be checked to ensure that they are in accordance with the data plate on the heater.

The gas supplier should check that the meter and service connection to the heater are capable of delivering the required volume of gas, thereby ensuring that the minimum burner pressure can be achieved.

Consideration should be given to the pressure drop on single and multi heater installations and the effect they may have on other plant sharing the supply.

If it is necessary to fit a gas pressure booster, the controls must include a low pressure cut off switch which must be fitted on the supply / inlet side of the booster. It is also a requirement that the gas supplier is advised prior to the installation or fitting of the booster.

Each heater supply must be fitted with a separate isolating cock positioned adjacent to and upstream of the union which must be sited outside the heater.

The isolating cock should be of the 90° turn type and should be clearly marked **OPEN / CLOSED** it should also be installed so as to fall to the closed position.

An approved gas jointing compound must be used on all joints and unions and the system purged and tested for soundness prior to final connection.

The connection to the heater can be made by way of either an approved flexible coupling or rigid connection. Threaded connections must comply to ISO 288/1 or ISO 7/1 further information concerning accepted European practice is detailed in BS EN1020.

The diameter of the pipework from the isolating cock to the burner must not be less than the diameter of the connection into the gas multiblock.

### Note

Reference to The Institute of Gas Engineers publications Utilisation Procedures IGE/UP1 and IGE/UP2 together with reference to BS6891 is strongly advised.

### 6.3.0 Commissioning

#### Note:

**It is a requirement that only suitably qualified and competent personnel are allowed to undertake the commissioning of the heater.**

**It is also strongly recommended that prior to commissioning the engineer familiarises himself with the heater, the specific requirements of the installation / application, and the information contained within the manual.**

### Warning

All heaters are subject to a rigorous test programme prior to despatch, whilst such a programme does involve pre-commissioning and the setting of the heater to operate efficiently and within its designed operational limits, this does not mean that the function of thorough on site commissioning is less important.

It is strongly recommended that the equipment used for the sampling and analysis of the flue gases is accurate to within +/- 0.1% and maintained so that it is regularly calibrated.

The following pre-commissioning checks should be undertaken, having first ensured that the gas and electrical supplies are turned off.

- (a) Check that all panels and fasteners are secure and in place.
- (b) Check that the heater is mounted safely.
- (c) Check that the flue is sealed, secured, and adequately supported.
- (d) Check that the fan is free to rotate, that the fan is secured to its shaft, and that the guards and fan assembly are all in place and properly secured.
- (e) Check that the heater is installed so that it is not tilted and remains square.
- (f) Check that the outlet louvres (Axial heaters) are set to offer minimum resistance to air flow.

### 6.3.1 Electrical pre-tests

The electrical safety checks must include the following:

- a) Test for earth continuity.
- b) Test for resistance to earth.
- c) Check live and neutral connections are correct.
- d) Check to ensure that when the external controls operate to switch the heater off, power remains to the fan.

### 6.3.2 Gas supply pre-test

Ensure that the service pipework has been installed, purged and tested in accordance with the relevant regulations, and that the installation is served by an adjacent isolating cock.

## 6. Commissioning & Testing cont.

Connection from the supply to the heater must also comply with the relevant regulations (see section 1.0) and must have been purged and soundness tested by an authorised engineer.

### 6.3.3 Ignition sequence

#### PRE START DRY RUN

In order to test that all controls are in good working order, the control sequence should first be tested with the gas supply turned **Off**.

Ensure gas isolating cock is in the **Off** position.

#### Warning

If during the following sequence of operations the heater fails to operate correctly the fault should be traced and rectified before proceeding, if necessary referring to fault diagnosis section.

- a) Switch off the main electrical supply to the heater.
- b) Turn off gas supply to the heater.
- c) Remove access panel (where applicable) and connect manometers to the gas supply test point and to the main burner test point.
- d) Ensure outlet louvres are correctly set.
- e) Ensure fan rotation is not impaired or obstructed.
- f) Set room thermostat(s) to its lowest setting
- g) If a time switch is fitted ensure it is set to an on period.
- h) Switch on electrical supply.
- i) Use leak tester to test for soundness on the unions and pipework.
- j) Operate the heater through the installed control system.  
*On start the signal will activate the flue venter for a pre purge period and in turn will make the air proving switch, once made, the air proving switch will complete the circuit to the control box and after a **30 second Delay** the automatic control should attempt light the burner, because the gas is turned off and flame cannot be established, the control box will go to **LOCKOUT**.*
- k) Reset the control on completion of dry run.
- l) Open gas cock.
- m) Operate heater through installed control.

*The flue venter will pre purge the heater and in turn operate an air proving switch which completes the electrical circuit to the control box after a **30 second Delay** the control will open the gas solenoid valve and the main burner will light. The flame can be observed at the burner manifold, check that the burner is providing a good flame i.e. even and stable.*

- n) Check pressure readings on the manometers,

and continue to let the heater fire for ten minutes.  
o) When the fan starts ensure that the direction of rotation is correct, and that the fan start is within 2 minutes of burner ignition.

#### Caution

If the fan fails to operate within approximately 2 minutes and the heater goes to overheat it will shut down through breaking the circuit to the gas valve, the cause must be ascertained and rectified before re-ignition.

Once the limit thermostat has tripped out it must be manually reset to allow re-ignition to take place.

- p) After ten minutes check burner head pressure is as specification - adjust as necessary by removal of the gas pressure adjustment cover, and using a screwdriver turn the adjustment screw on the governor as follows: Clockwise to increase. Anti clockwise to decrease.

*For Hi/Low and Modulation adjustment, refer to the following procedures*

#### IMPORTANT

*Adjustments should be made by qualified persons only.*

*If the appliance manufacturer supplies checkout and/or service and maintenance instructions, carefully follow them. If such instructions are not provided, then follow the procedure as outlined below.*

*Allow time for pressure to stabilize before making adjustments.*

*It is recommended that the High-Low regulator is operated a few times to ensure correct setting. It should be prevented, that High-Low regulator is exposed to unnecessary forces because of wiring.*

Remove the protective cap by putting a small screw driver in one of the slots and lifting carefully, while at the same time supporting the cap opposite the screw driver.

**Maximum pressure setting must first be adjusted then minimum pressure setting can be adjusted.**

**Any adjustment of maximum pressure setting influences minimum pressure setting.**

**Never adjust the maximum setting above the range specified.**

**Adjusting maximum pressure setting**

## 6. Commissioning & Testing cont.

- Connect a suitable pressure gauge to pipe line or to outlet pressure tap of gas control concerned, to measure burner pressure (measuring point must be as near to burner as possible).
- Energize High-Low regulator, set gas control in operation and wait until an outlet pressure is recorded on pressure gauge.
- Use a 8 mm wrench to turn adjustment screw for maximum pressure setting clockwise to increase or counter-clockwise to decrease pressure, until desired maximum burner pressure is obtained.
- Check maximum pressure setting after several times.

### Adjusting minimum pressure setting

- Connect a suitable pressure gauge to pipe line or to outlet pressure tap of gas control concerned, to measure burner pressure (measuring point must be as near to burner as possible).
- Disconnect electrical connection of High-Low regulator.
- Set gas control in operation and wait until an outlet pressure is recorded on the pressure gauge.
- When minimum pressure setting needs adjustment, then use a 3.5 mm screw driver to turn adjustment screw for minimum pressure setting clockwise to increase or counter-clockwise to decrease pressure, until desired minimum burner pressure is obtained.
- Wire High-Low regulator coil in circuit.

Check **maximum** pressure setting and re-adjust if necessary. Check minimum pressure setting again.

### **IMPORTANT**

### Adjustment of optional modulation regulator



*Adjustments should be made by qualified persons only.*

*If the appliance manufacturer supplies checkout and/or service and maintenance instructions, carefully follow them. If such instructions are not*

*provided, then follow the procedure as outlined below.*

*Allow time for pressure to stabilize before making adjustments.*

*It is recommended that the Modureg is operated a few times to ensure correct setting.*

The protective cap must be removed before any adjustment can be made. Remove the small retaining screw and lift the cap carefully.

Take care that after any adjustment, cap and O- ring are re-fitted (if applicable).

**The minimum pressure setting must first be adjusted to ensure that burner will safely light up, then maximum pressure setting can be adjusted.**

**Any adjustment of minimum pressure setting influences the maximum pressure setting.**

### Adjusting minimum pressure setting

- Disconnect pressure feedback connection (if applicable).
- Connect a suitable pressure gauge to pipe line or to outlet pressure tap of gas control concerned, to measure burner pressure (measuring point must be as near to burner as possible).
- Disconnect electrical connection to Modureg.
- Energize operator, set control in operation and wait until an outlet pressure is recorded on pressure gauge.
- If minimum pressure setting needs adjustment turn the adjustment for minimum pressure setting clockwise for increasing or counter-clockwise for decreasing pressure until the desired minimum outlet pressure is obtained.
- Check that main burner lights easily and reliably at minimum pressure.
- Check maximum pressure setting and readjust if necessary.
- Refit cap and "O" ring, and reconnect pressure feedback connection (if applicable)

## 6. Commissioning & Testing cont.

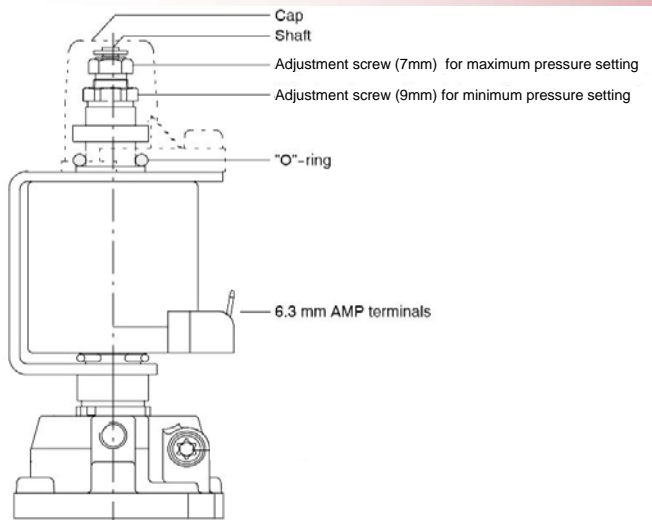

### Adjusting maximum pressure setting

- Disconnect pressure feedback connection (if applicable).
- Connect a suitable pressure gauge to pipe line or to outlet pressure tap of gas control concerned, to measure burner pressure (measuring point must be as near to burner as possible).
- Disconnect electrical connection of Modureg.
- Energize operator, set control in operation and wait until an outlet pressure is recorded on pressure gauge.
- Push the shaft gently downwards to the maximum adjustment screw and hold it on.
- If maximum pressure setting needs adjustment, turn the maximum rate adjustment screw clockwise for increasing or anti-clockwise for decreasing the maximum pressure, until the desired pressure is obtained. Release shaft.
- Refit cap and "O"ring and reconnect pressure feedback connection (if applicable).

When maximum and minimum pressure are set, wire Modureg in circuit.

### Checkout

After any adjustment, set appliance in operation and observe through several complete cycles to ensure that burner system components function correctly.

### Adjustment of modulation Interface board

#### **IMPORTANT**

*Adjustments should be made by qualified persons only.*

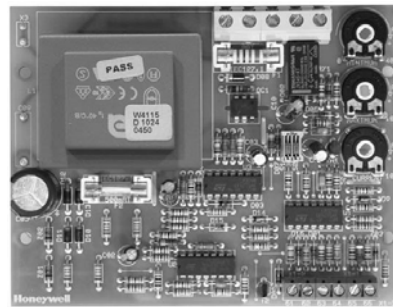

The interface board is a signal conditioner designed for the use in association a Honeywell modulation coil V7335A (Modureg). The purpose is to provide a linear conversion of a low DC voltage or current (produced by control equipment) to a requested control current or voltage for the modulation coil (0-10 V-DC or 4-20 mA-DC).

### Characteristics

#### Input signal

The interface board requires to be powered by a 230 VAC supply voltage.

Following control signals are available:

- 4 - 20 mA-DC with input protection for a continuous 200 mA signal (terminals 64-63).
- 0 - 5 V-DC with input protection for a continuous 35 V-DC signal (terminals 64-65).
- 0 - 10 V-DC with input protection for a continuous 35 V-DC signal (terminals 64-66).

*Note : Please ensure that the polarity '+' and '-' of the control signal is correct, otherwise the PCB will not operate correctly*

#### Output signal.

The required output signal can be obtained by adjusting the selector switches on the printed circuit board.

- For output control signal of one modulation coil V7335A (165mA)

Switch 1: "OFF"

Switch 2: "OFF"

### OPERATION

#### Adjustment & Control signals.

##### General

A relay with potential free contacts (terminals 5 & 6) incorporated within the interface board, controls the burner relay in the heater. This relay (burner on relay) is triggered each time there is an increase of the control current or voltage (room thermostat

## 6. Commissioning & Testing cont.

function).

### Adjustment of the minimum drop-out voltage of burner relay. Potentiometer P2.

The minimum drop-out voltage is controlled by a potentiometer P2, varying between 0 % and 40 % of the input control signal.

Example

- An input control signal of 0 to 10V DC and potentiometer P2 set at 0% results into a drop-out voltage of 0.3V DC.
- An input control signal of 0 to 10V DC and potentiometer P2 set at 40 % results into a drop-out voltage of 4V DC.

### Adjustment of the maximum hold-in voltage of burner relay. Potentiometer P3.

The maximum hold-in voltage is controlled by a potentiometer P3. Its proportional value is added to the P2 setting value.

Example:

- Potentiometer P2 is set at 0 %, and P3 at 5%, the hold-in voltage of the burner relay is adjustable between 5 % and 100 % of the input control signal. So, if input control signal is set at 0 to 10V DC, the hold-in voltage of the relay amounts to 0.5V DC.

- Potentiometer P2 is set at 40 % and P3 at 5%, the hold-in voltage of the burner relay is adjustable between 45 % and 100 % of the input control signal. So, if the input control signal is set at 0 to 10 VDC: the hold-in voltage of the relay amounts 4.5V DC.

### Adjustment of the current control. Potentiometer P1

The control current or voltage of one or two Honeywell modulation coils V7335A Modureg is controlled by the potentiometer P1, varying between 50 % and 100 % of the input control signal.

Example:

- Maximum power (165 mA-DC at 22V DC) is provided to the modulation coil with a 10V DC input control signal and P1 set at 100 %
- Maximum power (165mA-DC at 22V DC) is provided to the modulation coil with a 5V DC input control signal and potentiometer P1 set at 50 %.

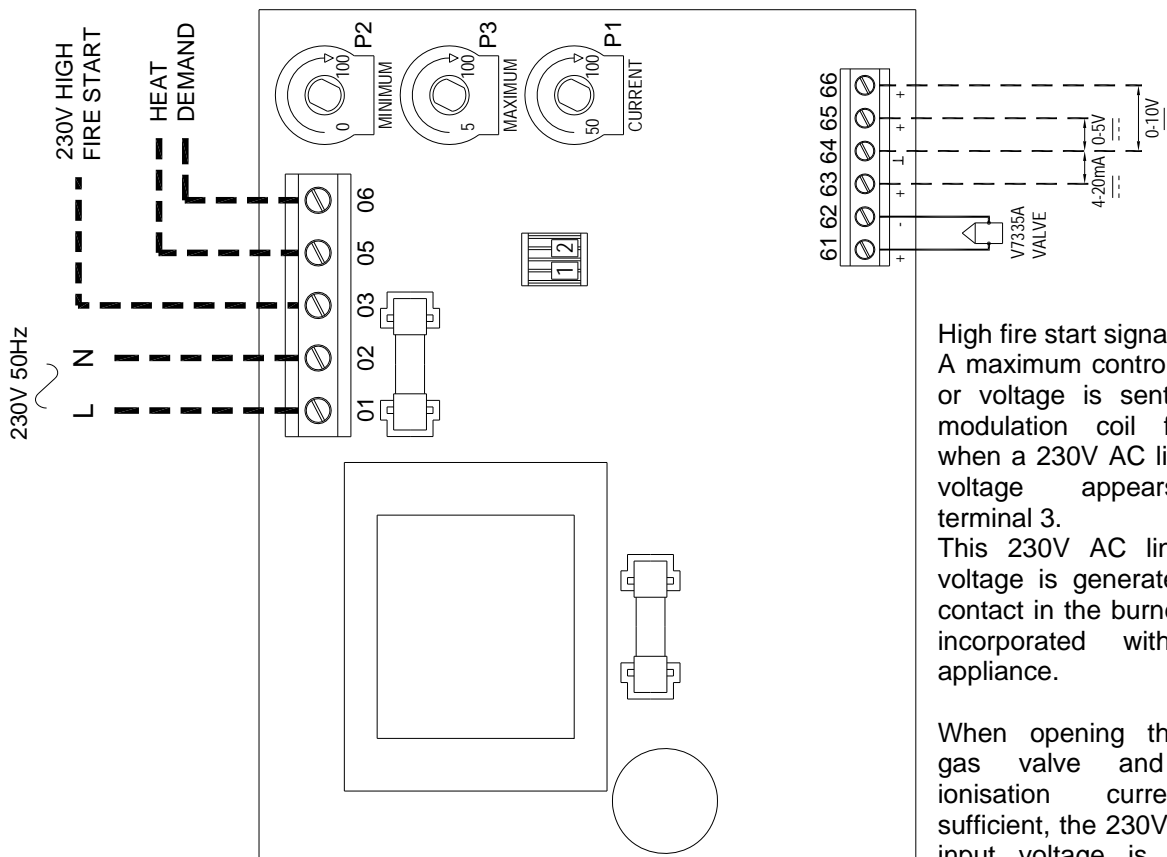

High fire start signal:  
A maximum control current or voltage is sent to the modulation coil for 10s when a 230V AC line input voltage appears on terminal 3. This 230V AC line input voltage is generated by a contact in the burner relay incorporated within the appliance.

When opening the main gas valve and when ionisation current is sufficient, the 230V AC line input voltage is directed towards terminal 3 of the interface board.

## 6. Commissioning & Testing cont.

- q) Check that the gas pressure remains satisfactory for all appliances on the same circuit.
- r) Undertake combustion tests checking CO, CO<sub>2</sub> and efficiency. CO should not exceed 20PPM.
- s) Check that the burners are extinguished when the thermostat is set to its lowest setting, and then remove the manometers.
- t) Turn the thermostat to its highest setting to re-light the burner and replace the adjustment screw cover.

***On completion mark the gas valve adjustment screw with paint/sealant to prevent tampering with valve.***

- u) Turn the thermostat to its lowest setting and shut off the gas supply at the gas control valve, allow the fan to continue to run until the heater is cooled sufficiently for the fan to shut down.
- v) Turn off the electrical supply.
- w) Replace access panel (where applicable)
- x) Set thermostat to desired setting.
- y) Ensure that the user is familiar with the heater and its controls and that the user is satisfied with the commissioning and testing, and that he is aware of the instructions within the manual.

It is strongly advised that the commissioning engineer runs through the lighting, shutdown, and general safe and efficient running of the heater before hand over.

### 6.3.4 Hand over

Upon satisfactory completion of commissioning and testing, a record of information (contact name date etc) should be made in the log book left with the heater by the commissioning engineer together with the user instructions.

At the same time the user should be made aware of the most efficient and economical methods of operation.

The user must be familiar and satisfied with the safety, ignition, shutdown, and general operational procedures.

### 6.4.0 Servicing

#### Warnings

**It is a requirement that only qualified personnel are allowed to carry out installation commissioning or servicing.**

**In addition only spare parts recommended by the manufacturer may be fitted, and the installer should provide a list of recommended spare parts that are available through the manufacturer or his agent (see page 36-39).**

**Before commencing any maintenance or servicing work the heater must be shut down and allowed to cool, and have the gas and electric supplies to it turned off at the supply cock and isolator respectively.**

**Always test for gas soundness after completing any service work particularly if this has necessitated the removal and / or replacement of gas carrying components.**

It is advisable that routine inspections are carried out. Servicing must also be carried out regularly, and in accordance with the manufacturers recommendations i.e. at a maximum interval of one year. In certain applications the frequency of servicing will have to be increased, governed by the working environment. Both the manufacturer and the installer will be able to offer further advice.

A safe working platform giving good access to the heater is required.

Clean all accessible surfaces including the outside of the tubular heat exchanger by removal of the fan assembly and the louvres. Check for panel damage and that all fasteners are present and secure.

Visually check all electrical wiring for signs of damage, possibly through contact with hot surfaces, check conduit for signs of chaffing and for security. Check all terminals are secure and free from escaped / stray conductor strands.

### 6.4.1 Servicing procedure - major component parts

#### Heat exchanger

Carry out visual inspection of the tubular heat exchanger using an inspection lamp and mirror.

Check seams and joints for perforations.

Check for severe corrosion and splits in the heat exchanger.

Check that there are no blockages and that there is not an excessive build up of soot within the heat exchanger.

If required remove the burner manifold allowing access for cleaning, with a flexible flue brush and vacuum cleaner.

**Warning** If the heat exchanger is found to be perforated the heater must not be fired until a replacement heat exchanger has been fitted.

#### Injectors and Manifold

## 6. Commissioning & Testing cont.

Undo the gas pipe connection.  
Remove the 6 manifold fixing screws.  
Remove the manifold and injector assembly from the right hand side of the heater.

Check that the manifold is straight, the injectors are correctly aligned, and that they are clean, and that there are no contaminants restricting the orifices. If necessary clean carefully with compressed air and or lint free cloth and acetone.

### **Caution**

**The injector orifice is precision machined to fine tolerances, do not clean with hard sharp or abrasive instruments. If the injectors have been removed from the manifold, when they are replaced, and care should be taken not to over tighten.**

**Ensure all joints are gas tight.**

### **Fan and Motor**

Check that the fan is secure and rotates freely without excessive play in the shaft.  
The fan blades and motor should be cleaned using a soft brush.

The fan and motor assembly can be removed from the heater by first disconnecting the leads from the terminal block and by removing the strain relief bush. The four screws securing the fan and motor assembly to the rear of the plenum can be removed, and the assembly complete with guard can then be removed from the heater.

### **Flue System**

Check that the flue is in good condition, that it is adequately supported, that there are no blockages or restrictions.

Check that any joints are properly sealed preventing an escape of products of combustion.

Check condensate drain if fitted.

Check for signs of water ingress and any resultant damage.

### **Flue Venter**

Check that the flue fan is clean and free from any dust deposits.

### **Differential Air Pressure Switch**

Check that the tubes are connected and clear and free from dust.

Check that they are not kinked or damaged.

Check electrical connections are intact.

### **Test**

Test and re-commission as per sections 6.3.0 to 6.3.4 inclusive.

### **Automatic Controls**

Automatic control is by way of a Honeywell controller.

Spark Ignition is via an ignition electrode ensure that the ceramic insulation material is not damaged or cracked.

Flame supervision is via a flame sensor rod.

Check the flame sensor rod for signs of pitting or corrosion, ensure that the ceramic insulation material is not damaged or cracked. Check connections are secure.

### **Main Governor**

To adjust the main governor, using a screwdriver remove the metal cover to reveal the adjustment screw, and turn as follows :

Clockwise to increase pressure.

Anticlockwise to decrease pressure.

## 6. Commissioning & Testing cont.

### 6.5 Dampers

#### Installation

When connecting ductwork to dampers take care to ensure that damper casing is not twisted by ductwork and that fixings do not penetrate cog housing of the damper which will affect the damper mechanism. Ductwork must be independently supported and should not be left to hang from the damper. Sealing should be in the form of a neoprene strip, or proprietary sealing compound.

Ensure actuator rotation is correct in relation to blade location to prevent breaking linkages.

#### 6.6 Maintenance

At six month intervals disconnect the actuator and check for freedom of movement.

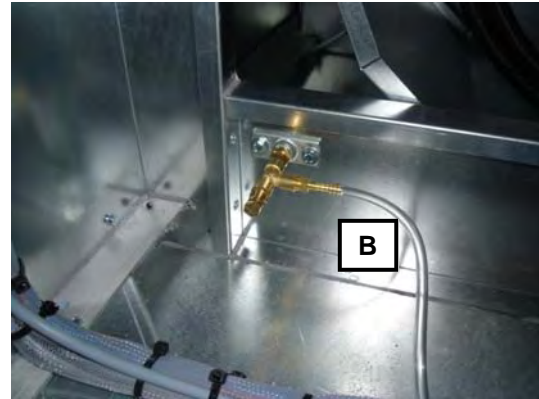

Page 4 refers to the EBM fan differential pressure. This differential pressure is taken between points A & B.

The pressure transducer then converts this pressure into a 0 -10 VDC signal, the voltage is then read by the BMS system and is calculated within the BMS into an air flow.

The pressure transducer is preset before despatch.

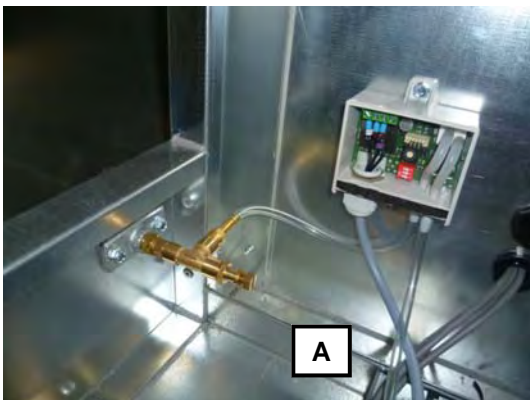
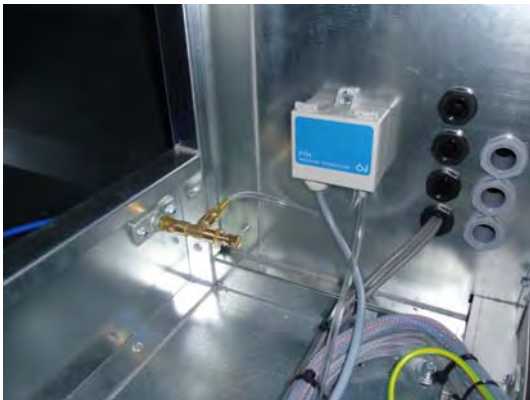

## 6. Commissioning & Testing cont.

### Technical Data

Appliance Type	B <sub>22</sub> C <sub>32</sub> C <sub>12</sub>
Electrical Protection	IP20

Country	Approved Gas Category
AT,BG,CH,CY,CZ,DK,EE,ES,FI,GB,GR,HR,IE,IT,IS,LT,LV,NO,PT,RO,SE,SI,SK,TR	I <sub>2H</sub>
BE,CZ,NL,FR,DE,IE,IT,ES,CH,PT,GB,SE,SK,SL,PT,PL,TR	I <sub>3P</sub>
PL,LU,DE,RO	I <sub>2E</sub>
PL	I <sub>2LS</sub>
PL	I <sub>2LW</sub>

## 6. Commissioning & Testing cont.

Technical Data - models DM 50 & 72		MODEL	
NAT GAS / LPG		50	72
HEAT OUTPUT	kW	49.0	72.0
	Btu	167,000	246,000
HEAT INPUT (NET)	kW	53.3	78.8
	Btu	181,700	268,900
EFFICIENCY	% Net	92.0	91.4
	% Gross	82.8	82.3
HEAT OUTPUT Low Fire	kW	23.6	34.9
	Btu	80,800	119,100
HEAT INPUT (NET) LOW FIRE	kW	26.7	39.4
	Btu	91,200	134,500
GAS CONNECTION	BSP/Rc	1/2"	3/4"
MIN INLET PRESS NAT GAS	mbar	17.5	17.5
	Ins WG	7	7
BURNER PRESSURE NATURAL GAS	mbar	8.3	8.7
	Ins WG	3.3	3.5
BURNER PRESSURE NATURAL GAS Hi/Low/Modulation	Hi mbar	8.3	8.7
	Lo mbar	2.1	2.3
MAIN INJECTOR NATURAL GAS	mm	2.2	3.4
	No Off	10	6
NATURAL GAS CONSUMPTION	ft <sup>3</sup> /hr	199	294
	m <sup>3</sup> /hr	5.63	8.33
MINIMUM INLET PRESSURE LPG	mbar	37.0	37.0
	Ins WG	14.8	14.8
BURNER PRESSURE LPG	mbar	28.3	25.5
	Ins WG	11.32	10.2
LPG CONSUMPTION	m <sup>3</sup> /hr	2.16	3.21
	Kg/h	4.00	5.94
MAIN INJECTOR LPG	mm	1.4	2.0
	No Off	10	6
FLUE DIAMETER	mm	100	130
COMBUSTION AIR DIAMETER	mm	100	130
SUPPLY VOLTAGE	V/P/Hz	230/1/50	230/1/50
ELECTRICAL POWER	amps	0.6	1.1
INTERNAL MCB	amps	6	6
GROSS FLUE TEMPERATURE	°C	150	150
WEIGHT (APPROX)	Kgs	113	168
FLUE RESISTANCE	min mbar	-0.1	-0.2
	max mbar	+0.2	+0.4

## 7. Controls

The Nordair Niche IDF units have an external IP65 isolator, which supplies an internal electrical base plate. Fitted on the base plate are;

- MCB's for the connection of the Mitsubishi heat pumps.
- Connections for EBM-Papst supply fan to control fan speed from the main HVAC panel.
- 240/24VDC power supply.
- POW-IO36 Modbus module, is a 36 channel combination module that combines four different module types. The POW-IO36 controls and monitors Mitsubishi PAC flow temperature controllers for the heat pumps, monitoring the supply air and supply liquid sensors.
- A numbered terminal strip where external connections are wired to and from the Mitsubishi condensers.
- A gas fired heating section is standard with the units.

Full control of the Nordair Niche IDF units is via the main HVAC panel, with communication via Modbus connection to the POW-IO36 module.

*Modbus cable Belden 9841NH*  
*Fire alarm cable red 1mm FP200*

### Kitchen Supply Air Handling Unit S1

#### S1 Supply Fan

EBM-Papst high performance fan fitted within AHU S1 ventilated compartment and wired to AHU terminal rail for external wiring to Trend by electrical contractor.

EBM-Papst fan connected to HVAC panel with power and hardwire controls via AHU terminal rail.

Mod-bus 'daisy chain' network cabling connected direct to the POW-IO36 within AHU.

Hardwired control cabling used for:-

- Start and stop control.
- Speed control.
- Fault alarm.
- Fan fault
- Flow failure alarm.

Panel mounted override switch "HVAC SUPPLY SYSTEMS - NORMAL/OFF/ALWAYS ON" – controls both S1 and S2 together.

No panel indication – refer to PC interface.

Trend controls fan to run to store open time schedule (separate from S2).

Heating and cooling held off when no flow or fault indicated via inverter.

Unit held off when fire alarm activated.

#### S1 Fan Speed Control

Fan speed set by commissioning engineer via user settable Trend settings as follows and recorded on commissioning sheet.

##### VH - Volume Heating

60% of VD.

Applied when actively heating by heatpump, electric, or gas burner.

##### VD - Volume Design

Specified system design volume (2.4m<sup>3</sup>/s for 150 unit).

Applied when cooling stages activated.

##### VM - Volume Maximum

Maximum considered tolerable from noise/draft perspective to maximise free cooling.

Varies between VH and VM, with E1 fan slaved in unison, according to load when free cooling is available and S1 is neither actively heating nor cooling.

#### S1 Mitsubishi Condensing Units General

Condensing units procured by HVAC contractor.

For each condensing unit - Mitsubishi FTC controller, leaving air temperature sensor and liquid line pipe sensor factory fitted by Nordair and wired to terminal rail for external connections.

Liquid line sensor fitted in spring clip brazed to pipe to facilitate removal. It is essential that the sensor is replaced with good contact to the pipe otherwise the Mitsubishi system will fault.

Mitsubishi key pad controller with LCD screen supplied with each S1 unit for access to

## 7. Controls cont.

Mitsubishi controls if required by plugging into AHU mounted socket provided in S1 and S2 air handling units (Note: Keypad controller should not normally be required for commissioning).

Condenser power supplies from factory fitted mcb's in AHU via terminal rail with external wiring by electrical contractor with local isolator at each condensing unit.

Hardwired control cabling from factory fitted FTC's in AHU via terminal rail with external wiring by electrical contractor.

Modbus 'daisy chain' network cabling to be connected to condensers when Mitsubishi confirm availability – initially for monitoring purposes only.

Condenser operation interlocked with supply fan run control, fire alarm activation and no flow/fault alarm from supply fan inverter.

### **S1 Cooling**

Stages (condensers) 1 and 2 (and 3 where applicable) activated by Trend from T1 room sensor.

Trend dictates required supply air temperature via 0-10v output simultaneously to each Mitsubishi FTC controller.

Each Mitsubishi FTC controller controls relevant condenser output to achieve supply air set point as dictated by Trend 0-10v output.

Minimum cooling set point (supply air) 12°C.

Consecutive cooling stages activated by Trend to provide overlap to encourage multiple stages at part load in preference to single stage at or near full load. This is to derive maximum benefit from increased COP at part condenser load.

All stages cooling held off below 12°C ambient.

### **S1 Heating Control Heat pump Only (where no gas or electric heating installed)**

Stages (condensers) 1 and 2 (and 3 where applicable) activated by Trend from T1 sensor.

Trend dictates required supply air temperature via 0-10v output simultaneously to each Mitsubishi FTC controller.

Each Mitsubishi FTC controller controls relevant condenser output to achieve supply air set point as dictated by Trend 0-10v output.

Minimum heating set point (supply air) to be maintained above room set point.

Maximum heating set point (supply air) 26°C.

Consecutive heating stages activated by Trend to provide overlap to encourage multiple stages at part load in preference to single stage at or near full load. This is to derive maximum benefit from increased COP at part condenser load.

### **S1 Heating Control Heat pump & Gas**

#### **Heat pump**

Heat pump heating used above 5°C ambient temperature.

Stages (condensers) 1 and 2 (and 3 where applicable) activated by Trend from T1 sensor.

Trend dictates required supply air temperature via 0 -10v output simultaneously to each Mitsubishi FTC controller.

Each Mitsubishi FTC controller controls relevant condenser output to achieve supply air set point as dictated by Trend 0-10v output.

Minimum heating set point (supply air) to be maintained above room set point.

Maximum heating set point (supply air) 26°C.

Consecutive heating stages activated by Trend to provide overlap to encourage multiple stages at part load in preference to single stage at or near full load. This is to derive maximum benefit from increased COP at part condenser load.

#### **Gas Heater (Benson Heater)**

Gas heater used below 5°C ambient temperature.

0 -10v Trend control output from the Trend controller via POW-IO36.

Trend control direct from T1 kitchen sensor and not via supply duct temperature.

Burner fault indication to Trend via AHU terminal rail.

### **S1 Heating Control Heat pump & Electric heater**

#### **Heat pump**

Heat pump heating stages (condensers) 1 and 2 (and 3 where applicable) activated by Trend from T1 sensor.

## 7. Controls cont.

Trend dictates required supply air temperature via 0-10v output simultaneously to each Mitsubishi FTC controller.

Each Mitsubishi FTC controller controls relevant condenser output to achieve supply air set point as dictated by Trend 0-10v output.

Minimum heating set point (supply air) to be maintained above room set point.

Maximum heat pump heating set point (supply air) 26°C.

Consecutive heating stages activated by Trend to provide overlap to encourage multiple stages at part load in preference to single stage at or near full load. This is to derive maximum benefit from increased COP at part condenser load.

### **36kW Electric Heater (if applicable)**

Integral AHU mounted single stage 36kW electric heater to be final heating stage after heat pump stages.

Electrical supply and internal controls integral to AHU, including high limit, trip, external illuminated run/trip indication and reset.

Electric heater located after Mitsubishi sensors, therefore does not conflict with heat pump heating controls.

Electric heater activation delay of 10min to ensure load satisfied by heat pumps if possible (on cold start-up).

Electric heater held off above 0°C ambient temperature.

Trend control direct from T1 kitchen sensor and not via supply duct temperature.

Heater trip fault indication to Trend via POW-IO36 .

### **Lobby Supply Air Handling Unit S2**

#### **S2 Supply Fan**

EBM-Papst high performance fan fitted within AHU S1 ventilated compartment and wired to AHU terminal rail for external wiring to Trend by electrical contractor.

EBM-Papst connected to HVAC panel with power and hardwire controls via AHU terminal rail.

Mod-bus 'daisy chain' network cabling connected direct to the POW-IO36 within AHU.

Hardwired control cabling used for:-

- Start and stop control.
- Speed control.
- Fault alarm.
- Fan fault.
- Flow failure alarm.

Panel mounted override switch "HVAC SUPPLY SYSTEMS - NORMAL/OFF/ALWAYS ON" – controls both S1 and S2 together.

No panel indication – refer to PC interface.

Trend controls fan to run to store open time schedule (separate from S1).

Heating and cooling held off when no flow or fault indicated via inverter.

Unit held off when fire alarm activated.

### **S2 FAN SPEED CONTROL**

Fan speed set at commissioning by commissioning engineer via user settable Trend settings as follows and recorded on commissioning sheet.

#### **VD- Volume Design at Full Fresh Air**

Specified system design volume in full fresh air mode (1.9m<sup>2</sup>/s for 120 unit; 2.4m<sup>3</sup>/s for 150).

Applied when cooling stages activated.

#### **VR- Volume Design at Maximum Recirculation**

Specified system design volume in min fresh air mode (1.9m<sup>2</sup>/s for 120 unit; 2.4m<sup>3</sup>/s for 150).

Applied when actively heating by heat pump, electric, or gas burner.

#### **VS - Volume Minimum**

70% of design volume in full fresh air mode.

#### **VM - Volume Maximum**

Maximum considered tolerable from noise/draft perspective to maximise free cooling.

Varies between **VM** and **VS** according to load when free cooling is available and S2 is neither actively heating nor cooling.

### **S2 ECONOMISER FREE COOLING OPERATION**

## 7. Controls cont.

S2 designated units supplied by Nordair Niche with automatic control dampers on fresh air intake and recirculation, each with individual 0-10V actuators and pre-wired to internal power supply and terminal rail for external wiring by electrical contractor.

### **Damper Control Strategy:-**

Heating Minimum fresh air which means:

**Where there are entrance doors to outside:-**

- 100% recirculation providing the return air duct is of sufficient capacity to accommodate the full AHU design air volume.
- Maximum recirculation volume achievable keeping total supply air volume within 70% of full design where return air duct is of insufficient size for the full AHU design air volume.

### **For basement and first floor areas with no entrances to outside:-**

- 85% recirculation providing the return air duct is of sufficient capacity to accommodate the 85% air volume.
- Maximum recirculation volume achievable keeping total supply air volume within 70% of full design where return air duct is of insufficient size 85% air volume.

Cooling  $T_O < T_R$  100% fresh air subject to minimum 10°C supply by modulation.

Cooling  $T_O > T_R$  Minimum Fresh air.

### **S2 Condensing Units General**

Condensing units procured by HVAC contractor.

For each condensing unit - Mitsubishi FTC controller, leaving air temperature sensor and liquid line pipe sensor procured and factory fitted by Nordair Niche and wired to terminal rail for external connections.

Liquid line sensor fitted in spring clip brazed to pipe to facilitate removal during pipe brazing on site to prevent heat damage. It is essential that the sensor is replaced with good contact to the pipe otherwise the Mitsubishi system will fault.

Mitsubishi key pad controller with LCD screen supplied with each S1 unit for access to

Mitsubishi controls if required by plugging into AHU mounted socket provided in S1 and S2 air handling units.

(Note: Keypad controller should not normally be required for commissioning).

Condenser power supplies from factory fitted mcb's in AHU via terminal rail with external wiring by electrical contractor with local isolator at each condensing unit.

Hardwired control cabling from factory fitted FTC's in AHU via terminal rail with external wiring by electrical contractor.

Mod-bus 'daisy chain' network cabling to be connected to condensers when Mitsubishi confirm availability – initially for monitoring purposes only.

Condenser operation interlocked with supply fan run control, fire alarm activation and no flow/fault alarm from supply fan inverter.

### **S2 Cooling**

Stages (condensers) 1 and 2 (and 3 where applicable) activated by Trend from T2 room sensor.

Trend dictates required supply air temperature via 0-10v output simultaneously to each Mitsubishi FTC controller.

Each Mitsubishi FTC controller controls relevant condenser output to achieve supply air set point as dictated by Trend 0-10v output.

Minimum cooling set point (supply air) 12°C.

Consecutive cooling stages activated by Trend to provide overlap to encourage multiple stages at part load in preference to single stage at or near full load. This is to derive maximum benefit from increased COP at part condenser load.

All stages cooling held off below 12°C ambient.

### **S2 Heating Control Heat pump Only (where no gas or electric heating installed)**

Stages (condensers) 1 and 2 (and 3 where applicable) activated by Trend from T2 sensor.

Trend dictates required supply air temperature via 0-10v output simultaneously to each Mitsubishi FTC controller.

## 7. Controls cont.

Each Mitsubishi FTC controller controls relevant condenser output to achieve supply air set point as dictated by Trend 0 -10v output.

Minimum heating set point (supply air) to be maintained above room set point.

Maximum heating set point (supply air) 36°C.

Consecutive heating stages activated by Trend to provide overlap to encourage multiple stages at part load in preference to single stage at or near full load. This is to derive maximum benefit from increased COP at part condenser load.

### **S2 Heating Control Heat pump & Gas**

#### **Heat pump**

Heat pump heating used above 5°C ambient temperature.

Stages (condensers) 1 and 2 (and 3 where applicable) activated by Trend from T2 sensor.

Trend dictates required supply air temperature via 0-10v output simultaneously to each Mitsubishi FTC controller.

Each Mitsubishi FTC controller controls relevant condenser output to achieve supply air set point as dictated by Trend 0 -10v output.

Minimum heating set point (supply air) to be maintained above room set point.

Maximum heating set point (supply air) 36°C.

Consecutive heating stages activated by Trend to provide overlap to encourage multiple stages at part load in preference to single stage at or near full load. This is to derive maximum benefit from increased COP at part condenser load.

#### **Gas Heater (Benson Heater)**

Gas heater used below 5°C ambient temperature.

0 -10v Trend control output from the Trend controller via POW-IO36.

Trend control direct from T2 kitchen sensor and not via supply duct temperature.

Burner fault indication to Trend via POW-IO36.

### **S2 Heating Control Heat pump & Electric heater**

#### **Heat pump**

Heat pump heating stages (condensers) 1 and 2 (and 3 where applicable) activated by Trend from T2 sensor.

Trend dictates required supply air temperature via 0-10v output simultaneously to each Mitsubishi FTC controller.

Each Mitsubishi FTC controller controls relevant condenser output to achieve supply air set point as dictated by Trend 0-10v output.

Minimum heating set point (supply air) to be maintained above room set point.

Maximum heat pump heating set point (supply air) 36°C.

Consecutive heating stages activated by Trend to provide overlap to encourage multiple stages at part load in preference to single stage at or near full load. This is to derive maximum benefit from increased COP at part condenser load.

#### **36kW Electric Heater (if applicable)**

Integral AHU mounted single stage 36kW electric heater to be final heating stage after heat pump stages.

Electrical supply and internal controls integral to AHU, including high limit, trip, external illuminated run/trip indication and reset.

Electric heater located after Mitsubishi sensors, therefore does not conflict with heat pump heating controls.

Electric heater activation delay of 10min to ensure load satisfied by heat pumps if possible (on cold start-up).

Electric heater held off above 0°C ambient temperature.

Trend control direct from T2 kitchen sensor and not via supply duct temperature.

Heater trip fault indication to Trend via POW-IO36

## 8. Air Filters

### COSHH Regulations

The components of filters are inherently safe, but changing air filters could expose operators to a 'nuisance dust' hazard. We would recommend that filter changing be carried out by maintenance personnel wearing simple dust masks, eye protection, overalls or protective clothing and gloves. Dirty filters should be sealed into plastic bags for disposal.

### Disposable filters

These are supplied in the forms of panel filters and are fitted into steel channel runners. Filters are simply withdrawn through the access door by sliding the filter along the channel runner. Filters should generally be replaced when the pressure drop increases to (125pa) above the initial level.







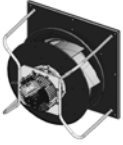

*Note: When replacing all filters ensure filter is facing correct direction as indicated by the airflow arrow.*

## 9. Routine maintenance schedule

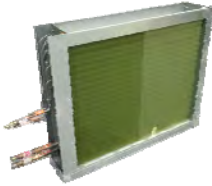



**Table 7**

	6 monthly	Annually
Fan/Motor	X	X
Heat exchangers	X	X
Dampers	X	X
Panel filters	X	X
External surfaces	X	X

## 10.Spare Parts

ITEM	PART NUMBER
 <p>Fan</p>	<p>N6337 (All EBM equipped IDF2 models)            N6338 (All EBM equipped IDF3 models)            N6341 (All EBM equipped IDF4 models)</p>
 <p>Pressure transducer</p>	<p>N0868 (All EBM equipped models)</p>
 <p>Mitsubishi controller</p>	<p>232769 (All models)</p>
 <p>Mitsubishi keypad</p>	<p>217248 (All models)</p>
 <p>Mitsubishi liquid/ air sensor</p>	<p>219488 (All models)</p>
 <p>Discharge sensor</p>	<p>TPTDS/S (All models)</p>
 <p>Modbus controller</p>	<p>POW-IO36MODE1 (IDF 2, 3, 4)            POW-IO36MODE2 (IDF 0.6, + IDF1 only)</p>
 <p>Filters</p>	<p>IDF2 models: 4 x N4487            IDF3 models: 4 x N4444 + 2 x N4445            IDF4 models: 1 x N4440 + 3 x N4443 + 2 x N4444</p>
 <p>Light sensor</p>	<p>TPLLO (All S1 models)</p>
 <p>Outside Air sensor</p>	<p>TPTOS (All S1 models)</p>

# 10. Spare Parts cont.

Heater Ref.	 <b>DX Coil</b>	 <b>Gas Heater</b>	 <b>Damper</b>	 <b>Damper Motor</b>
IDF2BDX90 S1	28KWDX90COIL	33-64-918 or 33-64-9185IL	N/A	
IDF2BDX90 S2			N8201	N9002
IDF2DX90 S1		N/A	N/A	
IDF2DX90 S2			N8201	N9002
IDF2BDX120 S1	38KWDX120COIL	33-64-9185 or 33-64-9185IL	N/A	
IDF2BDX120 S2			N8201	N9002
IDF2DX120 S1		N/A	N/A	
IDF2DX120 S2			N8201	N9002
IDF2BDX150 S1	44KWDX150COIL	33-64-9185 or 33-64-9185IL	N/A	
IDF2BDX150 S2			N8201	N9002
IDF2DX150 S1		N/A	N/A	
IDF2DX150 S2			N8201	N9002
IDF3BDX180 S1	52KWDX180COIL	33-64-9270 or 33-64-9270IL	N/A	
IDF3BDX180 S2			N8033	N9002
IDF3DX180 S1		N/A	N/A	
IDF3DX180 S2			N8033	N9002
IDF3BDX200 S1	63KWDX200COIL	33-64-9270 or 33-64-9270IL	N/A	
IDF3BDX200 S2			N8033	N9002
IDF3DX200 S1		N/A	N/A	
IDF3DX200 S2			N8033	N9002
IDF4BDX240 S1	66KWDX240COIL	33-64-9270 or 33-64-9270IL	N/A	
IDF4BDX240 S2			N8034	N9002
IDF4DX240 S1		N/A	N/A	
IDF4DX240 S2			N8034	N9002

# 10.Spare Parts cont.

ITEM	PART NUMBER	
	DM 50	DM 72
 Modulating Valve	Valve Body 28-30-180 Head 28-30-200	Valve Body 28-30-181 Head 28-30-200
 Valve Gasket	33-64-226	33-64-227
 Modulation Interface Board	28-30-198	
 Control Box	29-01-173	29-01-183
 Pressure Switch	201676 (Huba red)	201932 (Huba yellow)
 Fan Limit Stat	28-16-059	
 Overheat Stat	28-16-058	
 Injector Natural Gas	33-64-144	33-64-145
 Injector Propane Gas	33-67-971	33-64-147
 Flue Fan	28-09-084	28-09-089

## 10.Spare Parts cont.

ITEM	PART NUMBER	
	DM 50	DM 72
 Electrode	33-64-193	
 Ionisation Probe	33-64-194	
 Overheat Red Neon	28-50-030	
 Burner On Green Neon	28-50-038	
 Reset Relay 230V	28-25-039	
 Relay Base	28-25-035	
 High Fire Timer Relay	28-15-027	
 MCB (6A)	28-07-084	
 Lockout Reset Switch	28-40-118	
 Inshot Burner	33-64-158	33-64-160

## 11. User Instructions

### Display this near your heater

#### Important

For safe and satisfactory operation, these instructions should be read and fully understood.

#### General

For continued safe and efficient operation, this heater should be serviced regularly by a competent service engineer. A full after sales service is available from Nordair Niche. Read the warranty and ensure that the heater is operated within the terms of the warranty. Maintain free access to the heater for servicing and do not restrict the air supply to the heater.

#### For your safety

- Ensure that the heater is properly earthed.
  - If a gas leak is suspected, turn off the gas supply and contact the gas supplier immediately.
- DO NOT USE A NAKED FLAME to inspect gas leaks.

#### To turn the heater on

1. Turn 'ON' the gas supply and the electrical supply to the heater.
2. The time and temperature control of the heater is under the dictates of a time temperature controller and will start automatically.

#### Note

- On initial start-up, several attempts may be required to purge the air from the multifunctional control valve.
- If the heater will not 'start' on initial start-up, the ignition controller may be in lockout position. Depress the reset button.
- After measuring the gas pressure, ensure the cap is refitted.

#### Normal operating sequence

1. On time signal start, main supply fan starts.
2. Room sensor calling for heat, flue venter commences a purge period followed by ignition of the main flame.
3. Below room set point, the burner will fire at maximum heat input, until room set point is achieved. Depending on the type of control fitted i.e. modulating, high/low or on/off, the heater input will be reduced accordingly.

4. Room temperature exceeding room set point will shut down the burner. Main supply fan will continue to run.

5. On time schedule shutdown the burner and main fan is shut down. Outside of the time schedule frost protection will start the heater.

#### Note

The fan will continue to operate until the heat exchanger has cooled down.

#### To shut down the heater for a short period

Override the time/temperature controller to 'off'. To reinstate the heater operation, override the controller to 'ON'.

#### To shut down the heater for an extended period

- Override the time/temperature controller to 'OFF'. Isolate the gas and electrical supplies.

#### Operation note

If a momentary interruption to the gas occurs, the burner will automatically lockout. Burner lockout must be manually reset.

If the heater continues to lockout after 3 or 4 consecutive attempts at ignition, contact Nordair Service Department or your own service company.

In the event of the heater going into an overheat condition, wait 30 seconds before resetting. If the heater continues to go to overheat after 3 or 4 consecutive attempts, contact Nordair Niche Service Department or your own service company.

#### Maintenance and service

To ensure safe and efficient operation, this heater should be serviced at least annually. It is strongly recommended that the installing heater engineer or Nordair Niche Service Division be contacted to provide the necessary service. Retain on file a copy of the service instructions for this heater.

To clean the appliance cabinet, wipe the surfaces with a damp cloth, containing a mild detergent.

# 12. Wiring Diagrams.

## Wiring Diagram 33-67-742 DM-50 Auto ignition Modulation

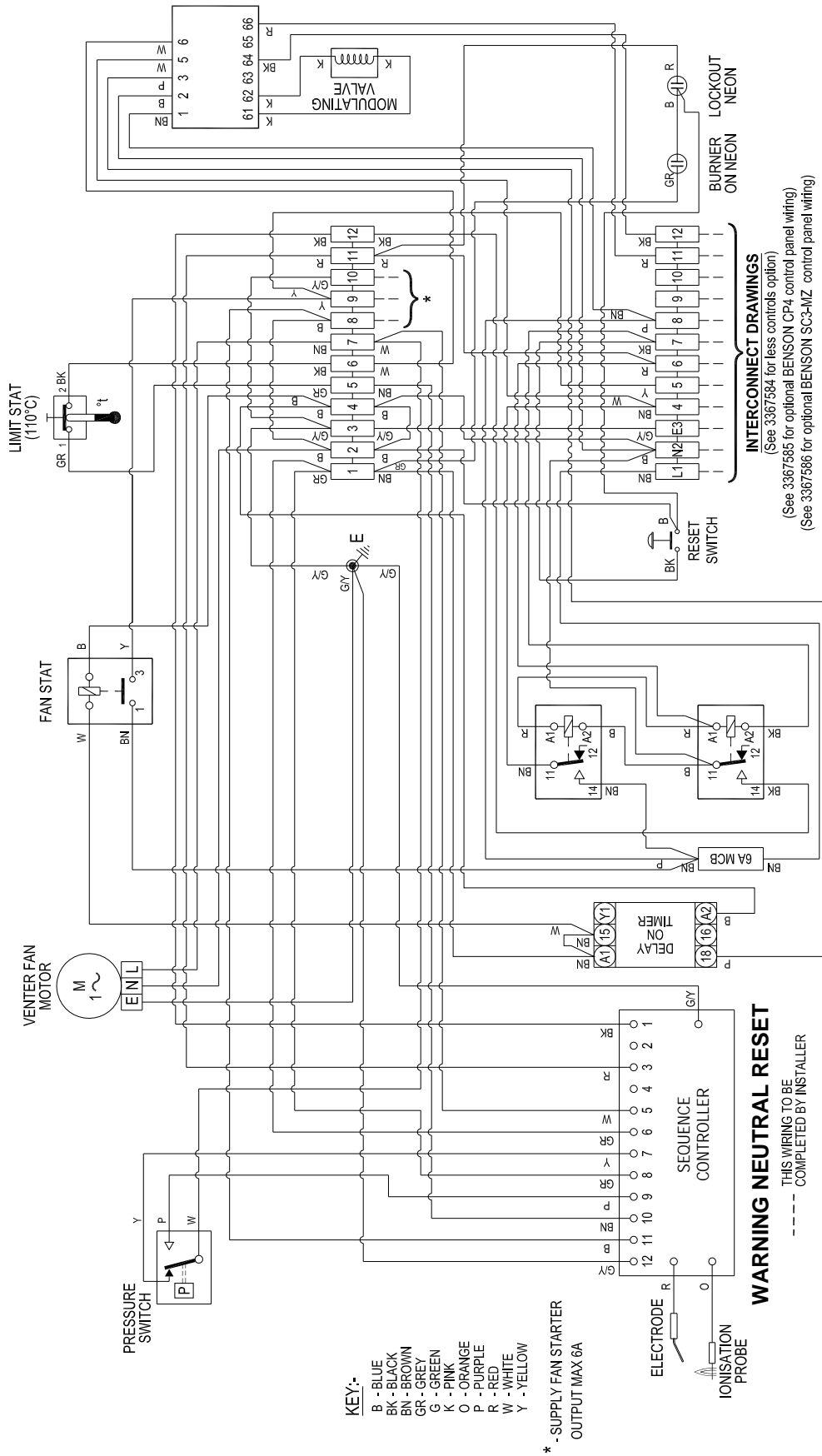

# 12. Wiring Diagrams cont.

## Wiring Diagram 33-67-745 DM-72 Auto ignition Modulation

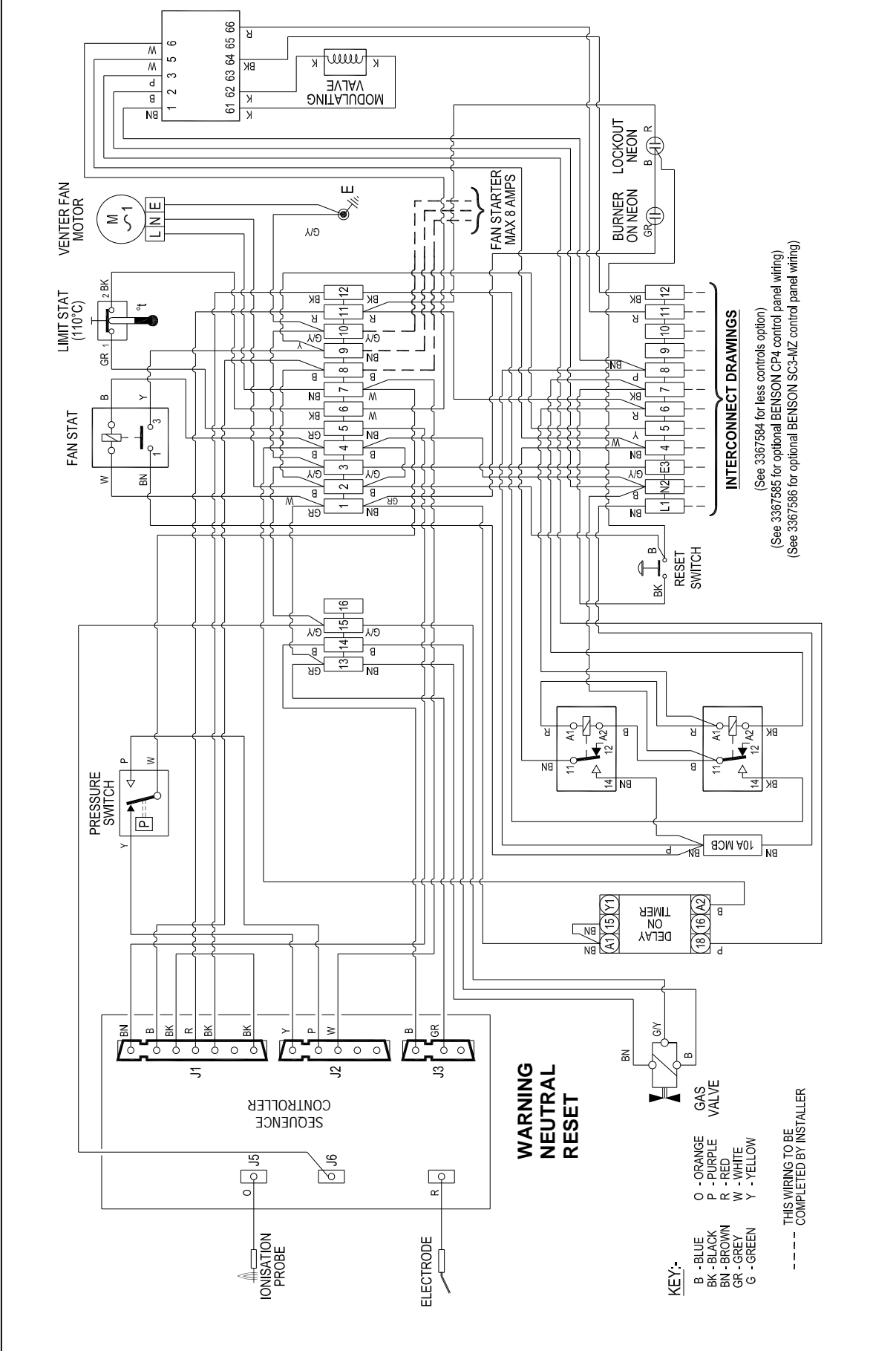



# 12. Wiring Diagrams cont.

## Schematic Wiring Diagram McDonalds IDF2BDX90, 120, 150(EBM)MOD UNIT SHEET 2 OF 5

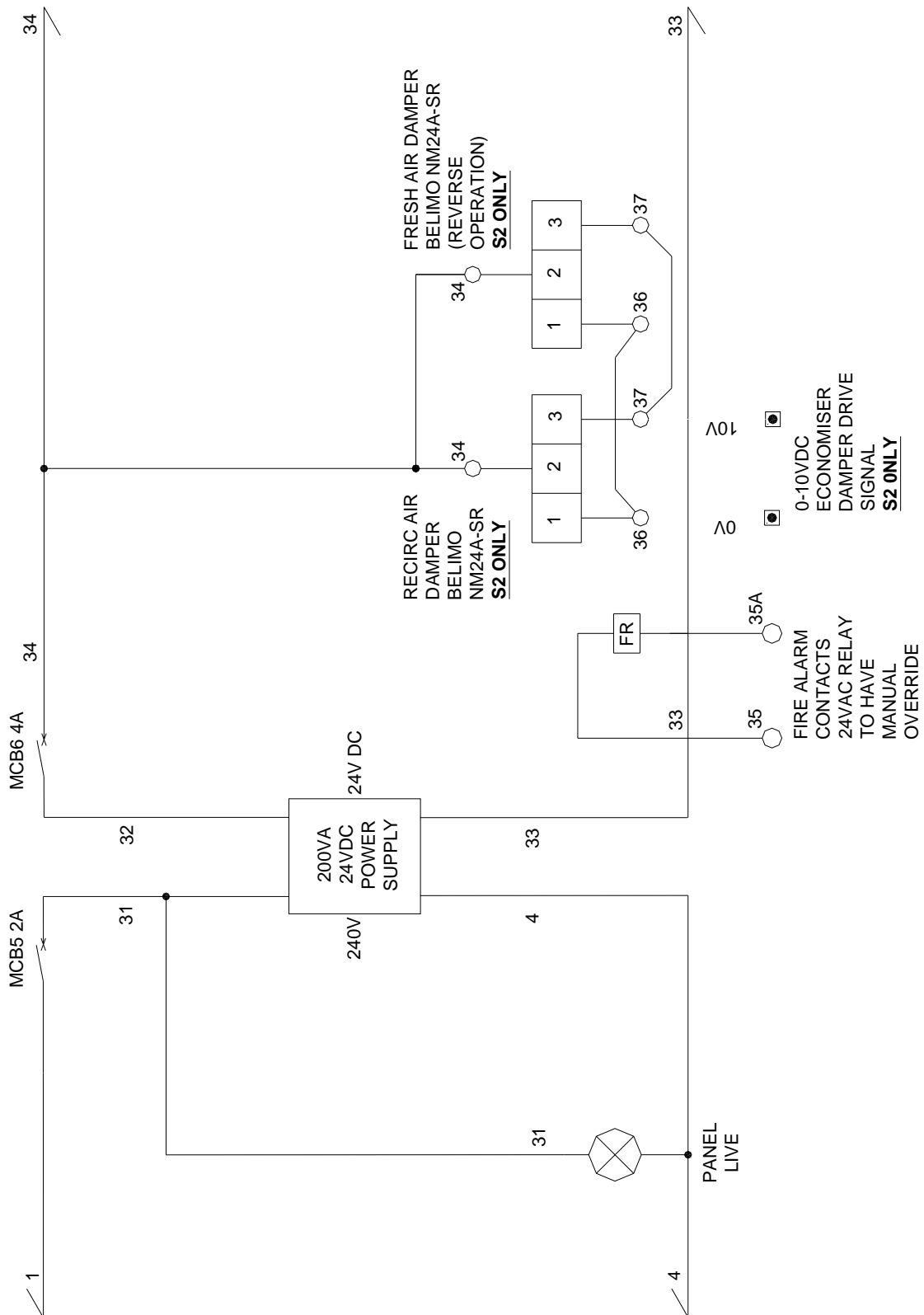

# 12. Wiring Diagrams cont.

## Schematic Wiring Diagram McDonalds IDF2BDX90, 120, 150(EBM)MOD UNIT SHEET 3 OF 5

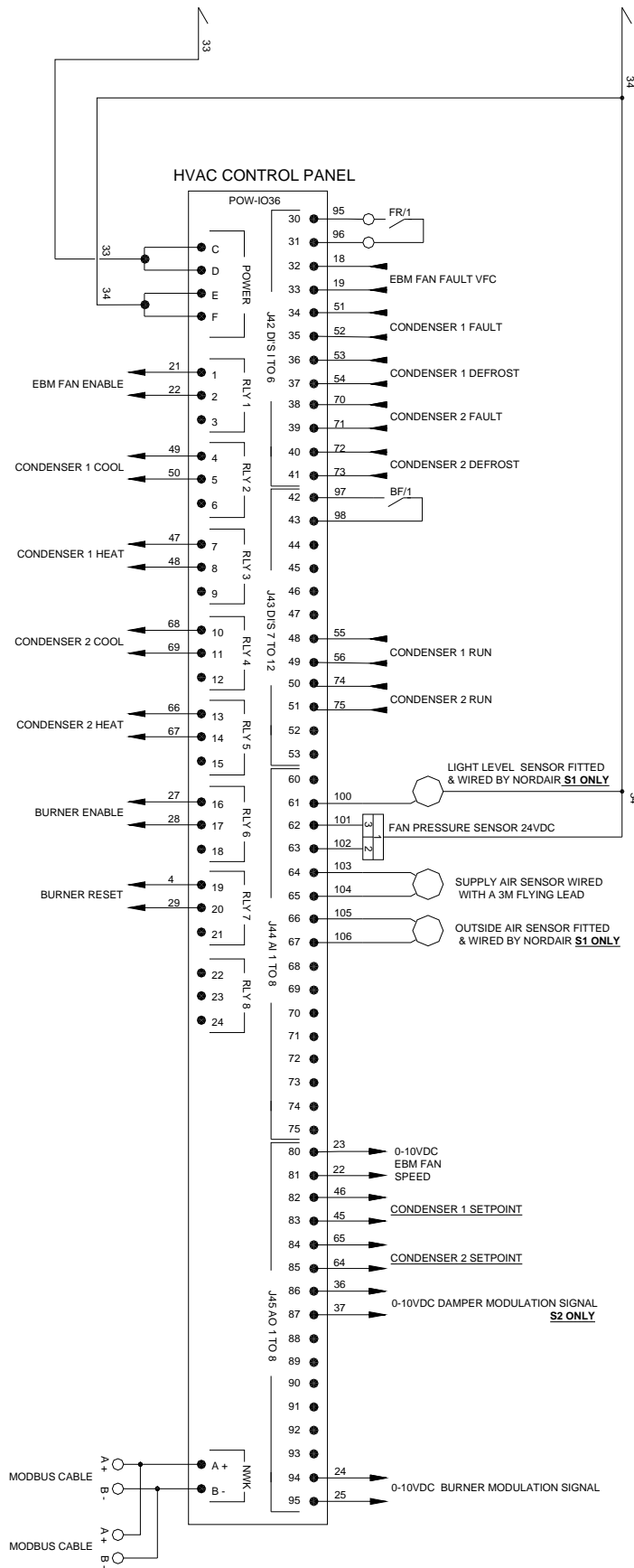

# 12. Wiring Diagrams cont.

## Schematic Wiring Diagram McDonalds IDF2BDX90, 120, 150(EBM)MOD UNIT SHEET 4 OF 5

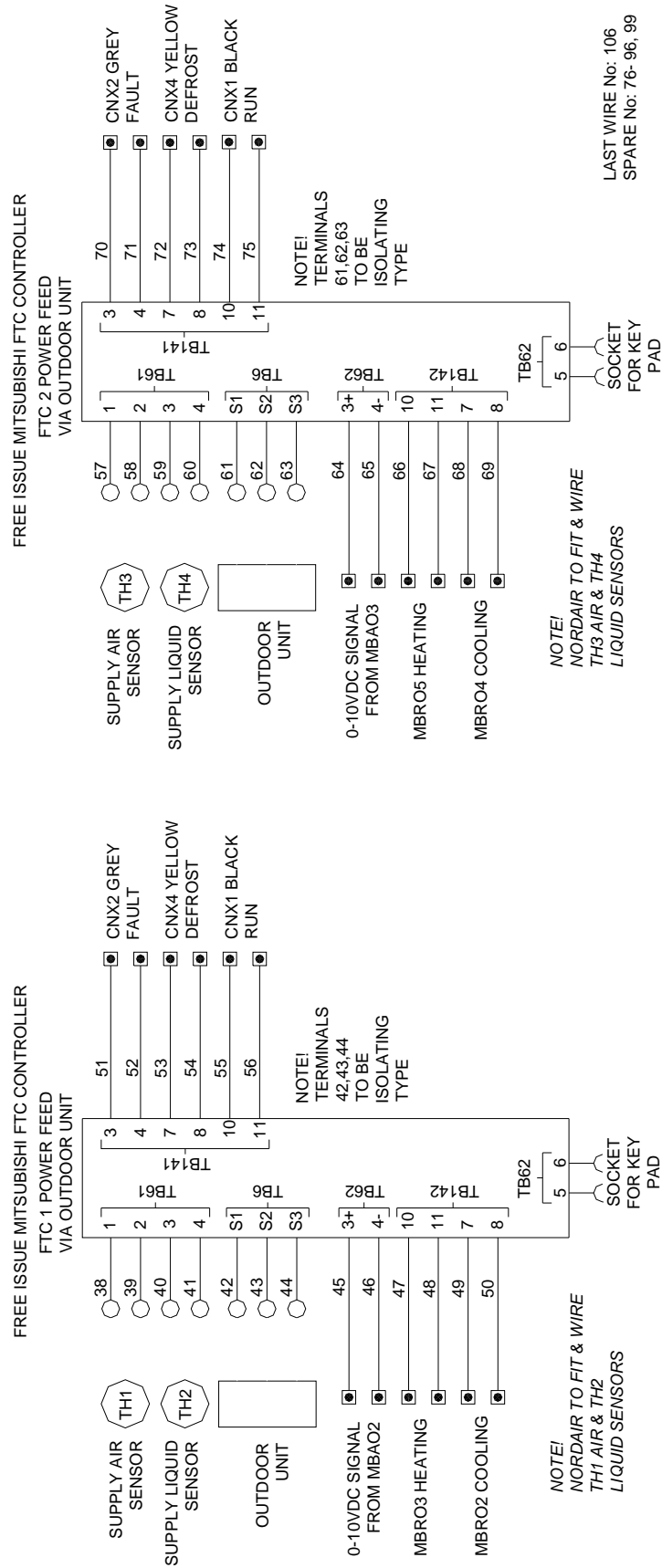

# 12. Wiring Diagrams cont.

## Schematic Wiring Diagram McDonalds IDF2BDX90, 120, 150(EBM)MOD UNIT SHEET 5 OF 5

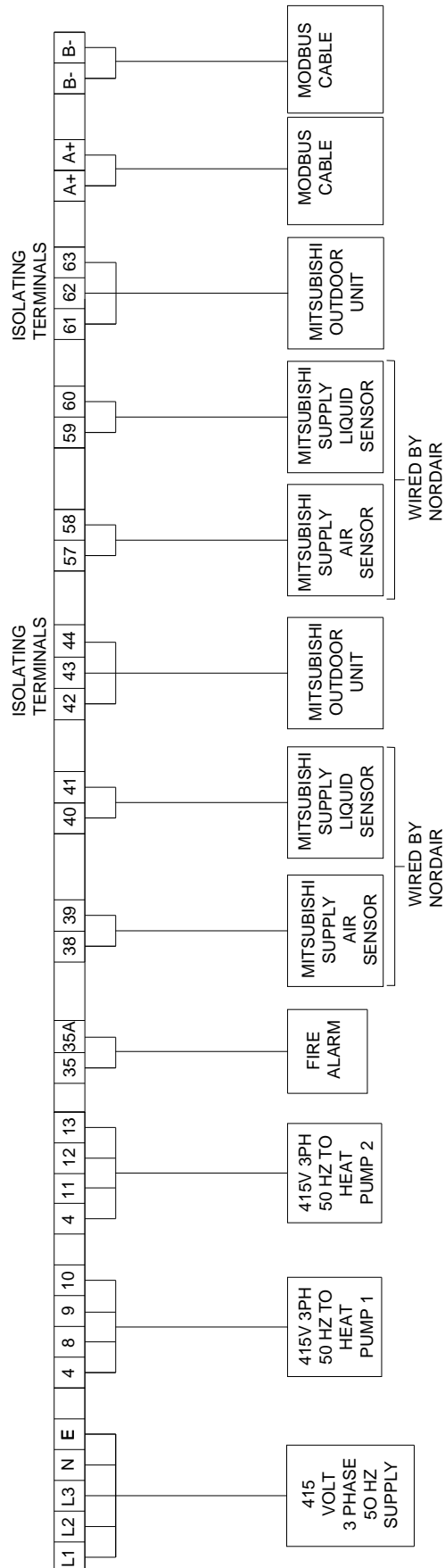

# 12. Wiring Diagrams cont.

## Schematic Wiring Diagram McDonalds IDF3BDX180, 200/IDF4BDX240(EBM)MOD UNIT SHEET 1 OF 5

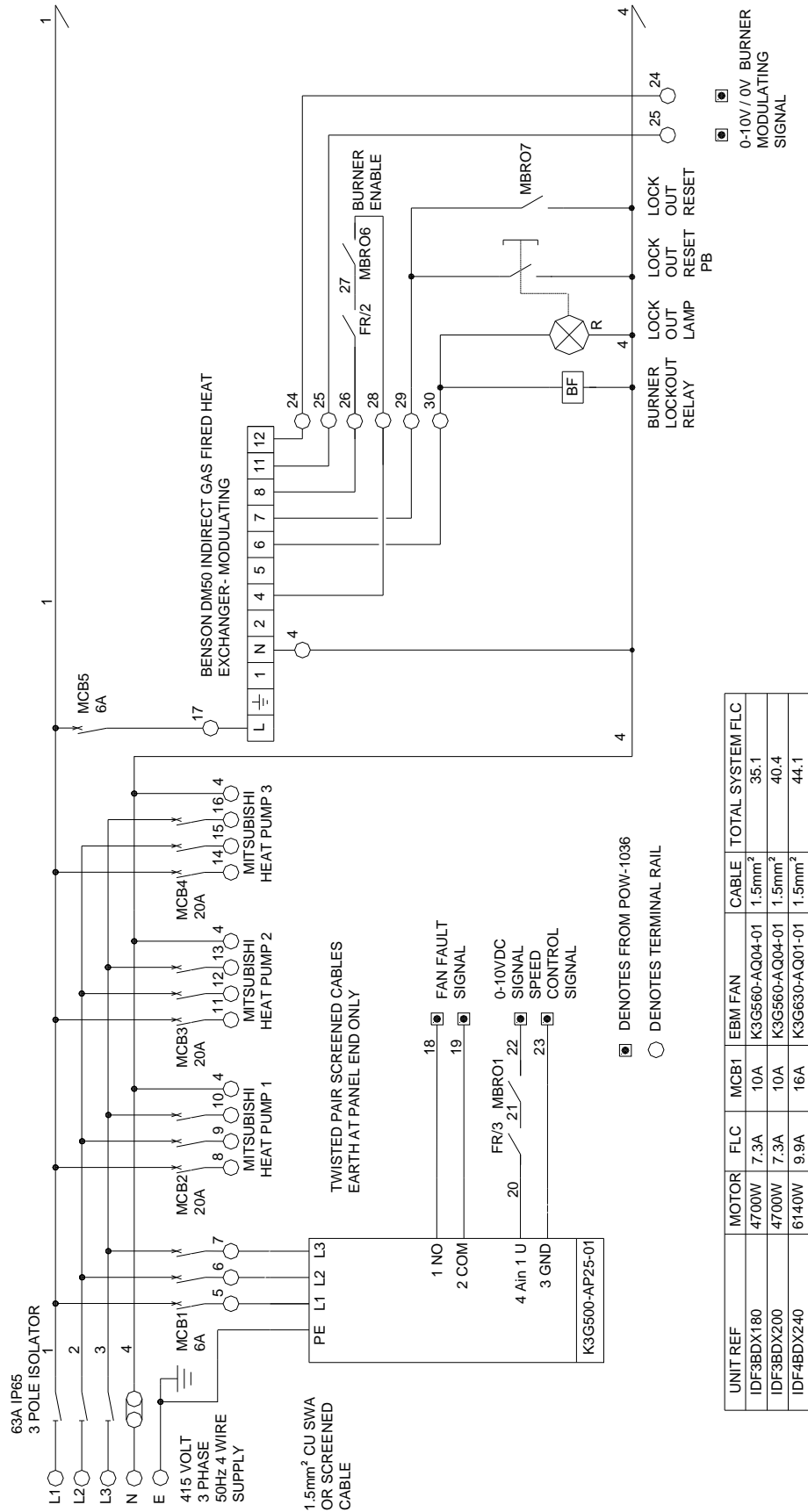

UNIT REF	MOTOR	FLC	MCB1	EBM FAN	CABLE	TOTAL SYSTEM FLC
IDF3BDX180	4700W	7.3A	10A	K3G560-AQ04-01	1.5mm <sup>2</sup>	35.1
IDF3BDX200	4700W	7.3A	10A	K3G560-AQ04-01	1.5mm <sup>2</sup>	40.4
IDF4BDX240	6140W	9.9A	16A	K3G630-AQ01-01	1.5mm <sup>2</sup>	44.1

# 12. Wiring Diagrams cont.

## Schematic Wiring Diagram McDonalds IDF3BDX180, 200/IDF4BDX240(EBM)MOD UNIT SHEET 2 OF 5

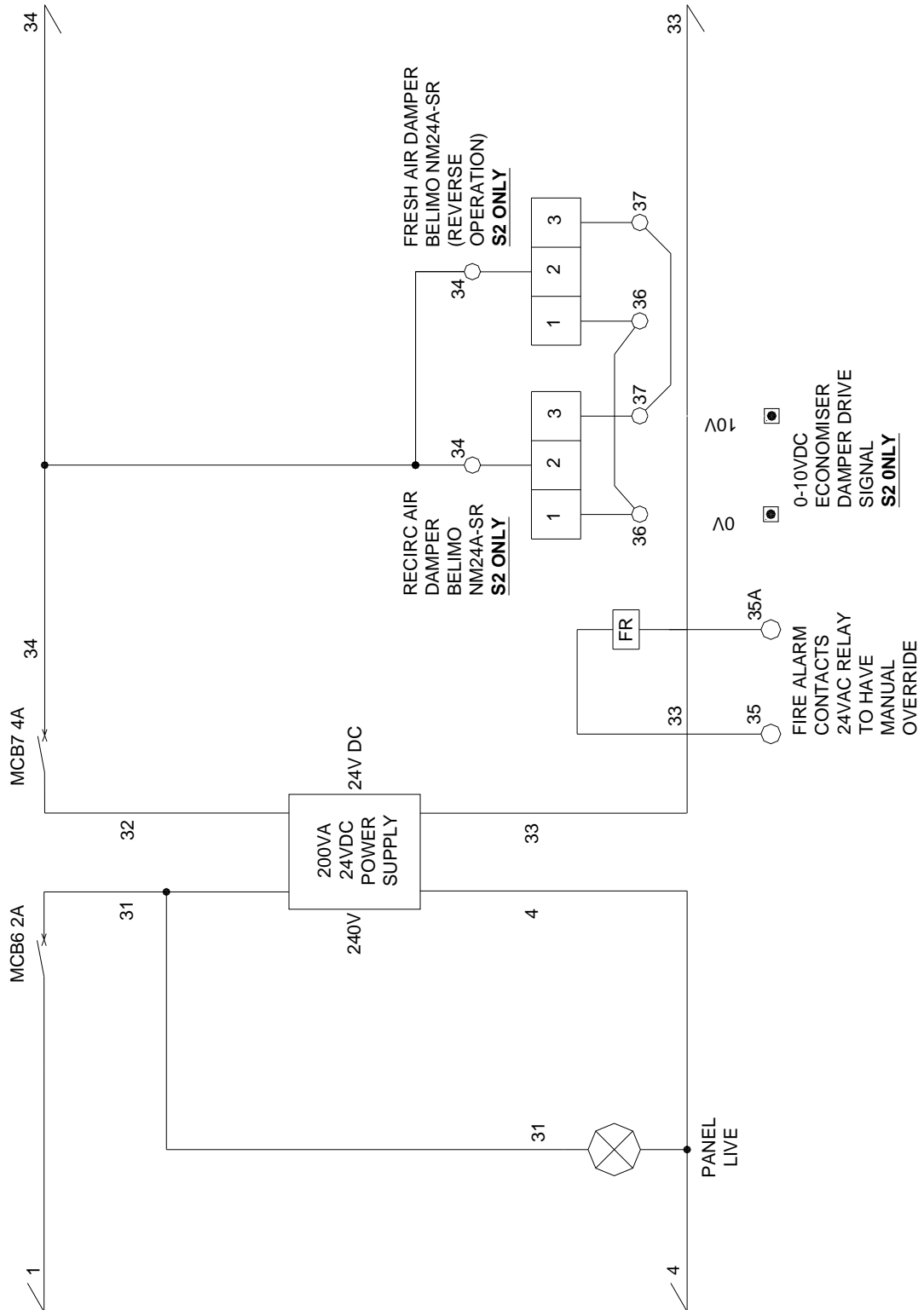

# 12. Wiring Diagrams cont.

## Schematic Wiring Diagram McDonalds IDF3BDX180, 200/IDF4BDX240(EBM)MOD UNIT SHEET 3 OF 5

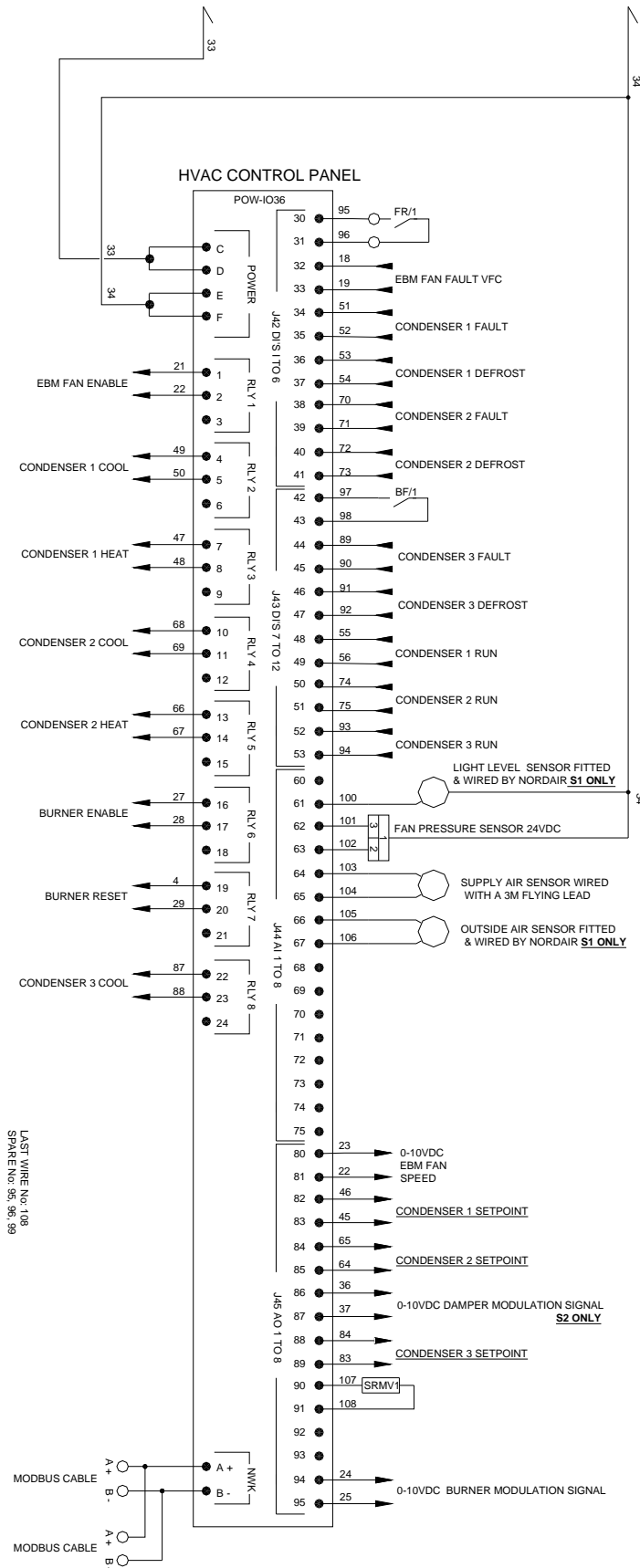

# 12. Wiring Diagrams cont.

## Schematic Wiring Diagram McDonalds IDF3BDX180, 200/IDF4BDX240(EBM)MOD UNIT

SHEET 4 OF 5

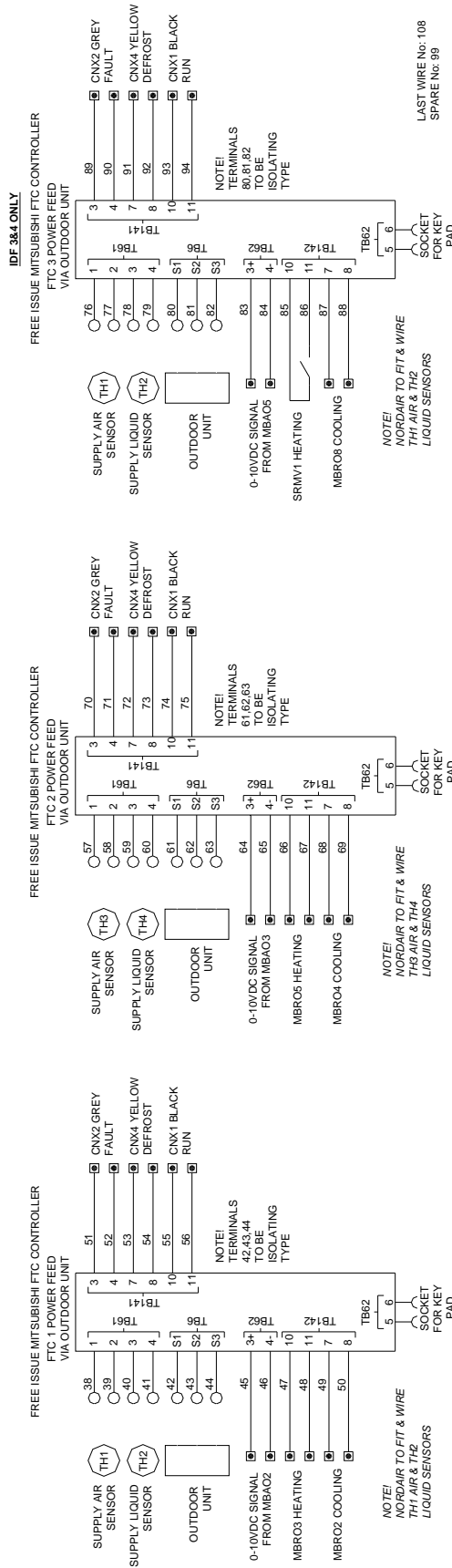

# 12. Wiring Diagrams cont.

## Schematic Wiring Diagram McDonalds IDF3BDX180, 200/IDF4BDX240(EBM)MOD UNIT

SHEET 5 OF 5

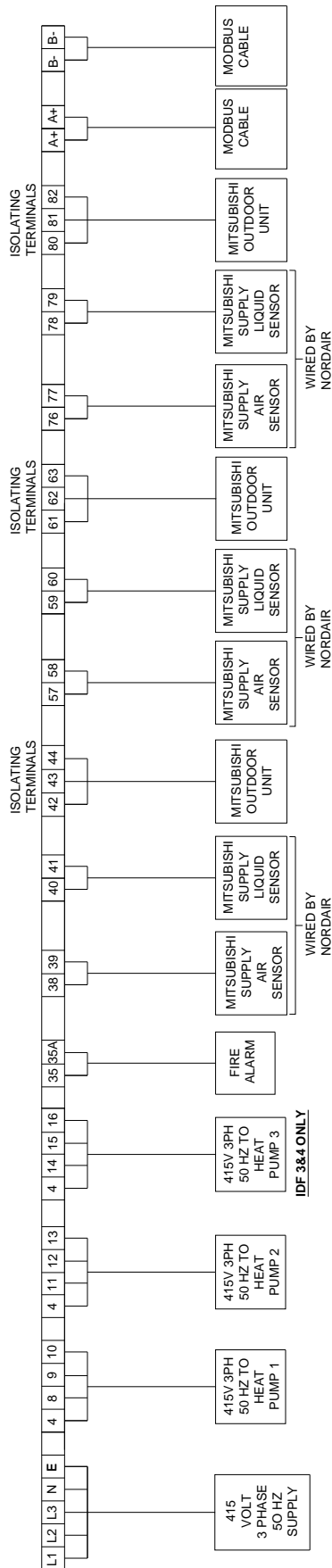

# 12. Wiring Diagrams cont.

## Schematic Wiring Diagram McDonalds IDF0.6DXHXPL UNIT SHEET 1 OF 4

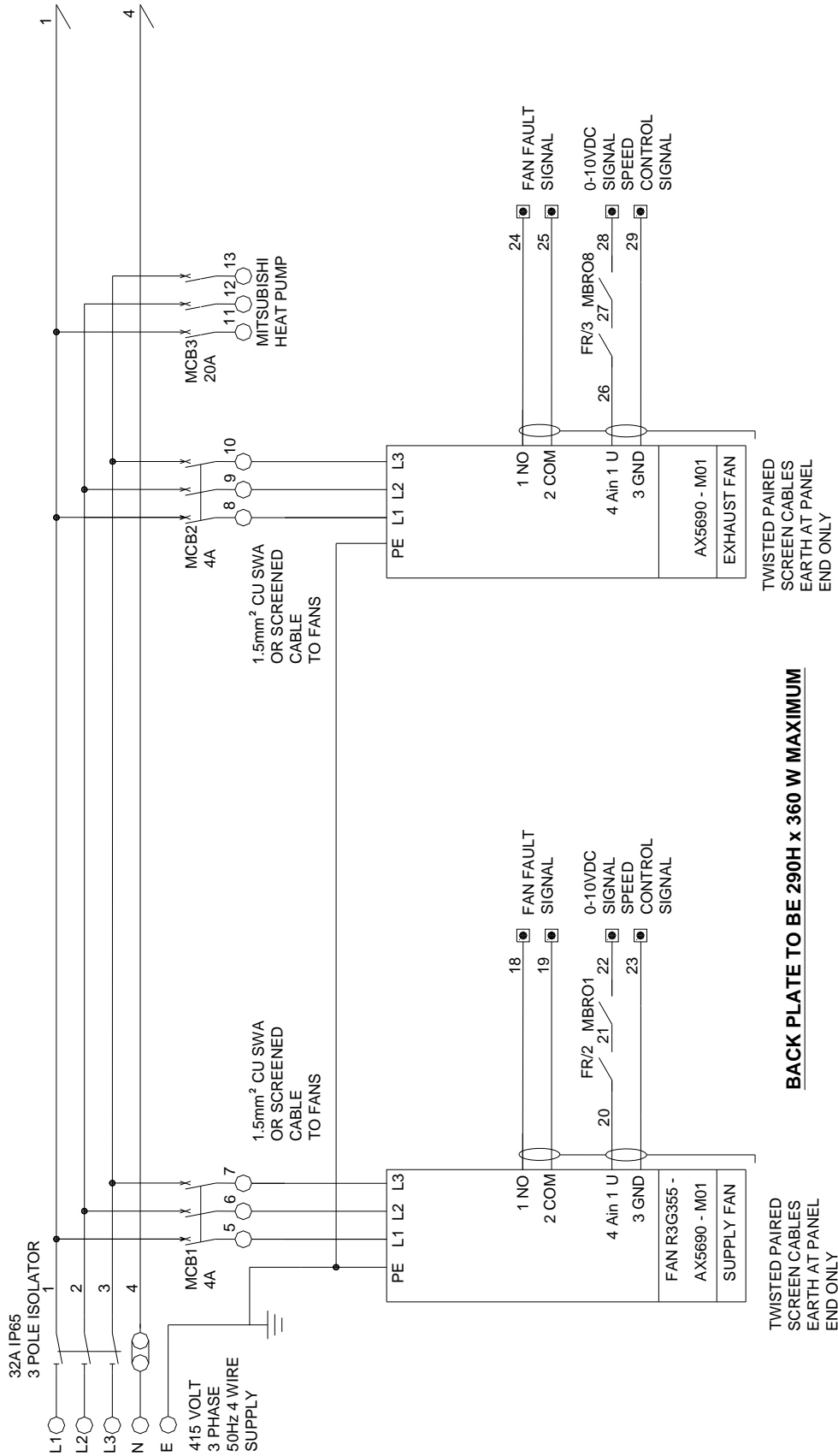

**BACK PLATE TO BE 290H x 360 W MAXIMUM**



# 12. Wiring Diagrams cont.

## Schematic Wiring Diagram McDonalds IDFO.6DXHXPL UNIT

SHEET 3 OF 4

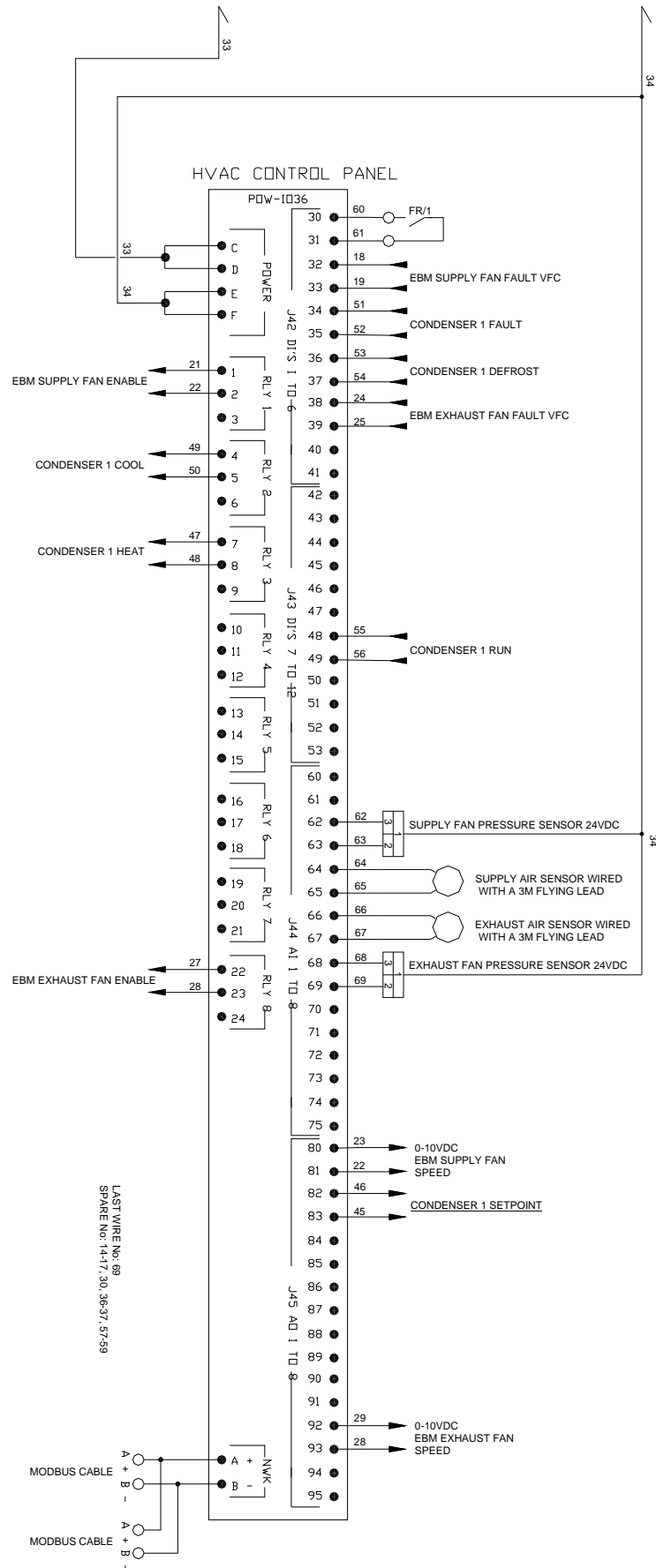

# 12. Wiring Diagrams cont.

## Schematic Wiring Diagram McDonalds IDF0.6DXHXPL UNIT

SHEET 4 OF 4

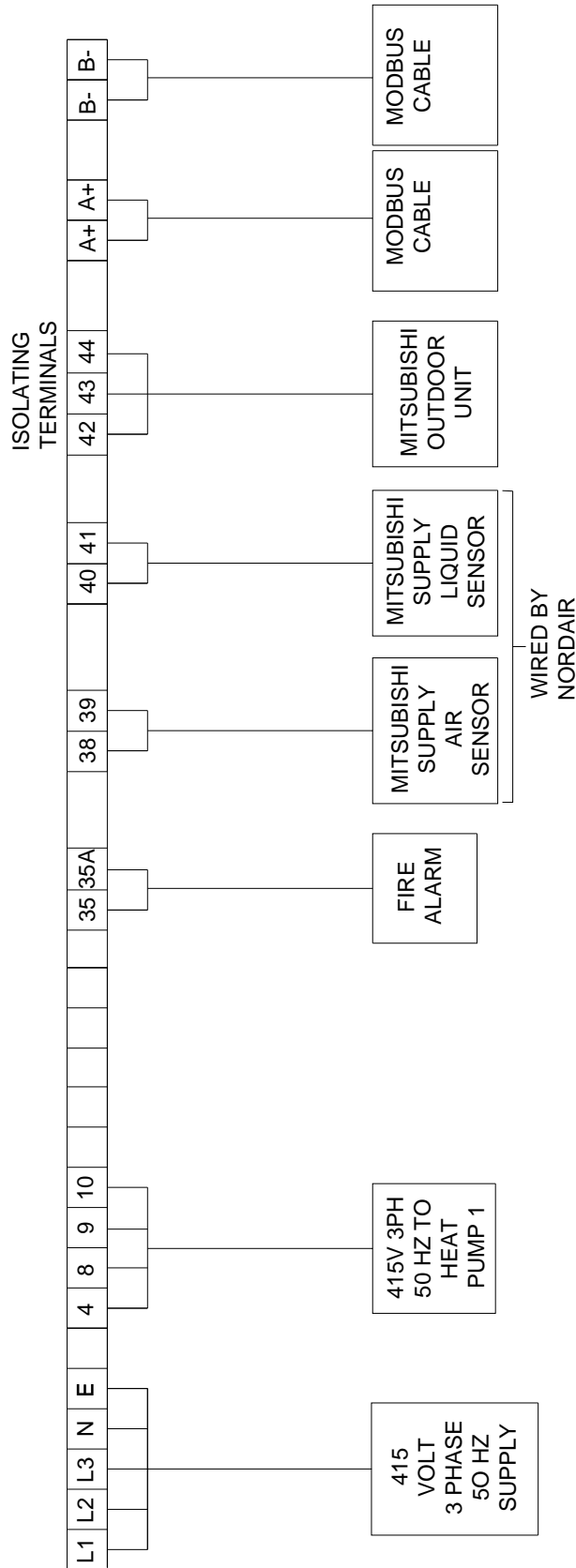





# 12. Wiring Diagrams cont.

## Schematic Wiring Diagram McDonalds IDF1DXHXPL UNIT

SHEET 3 OF 4

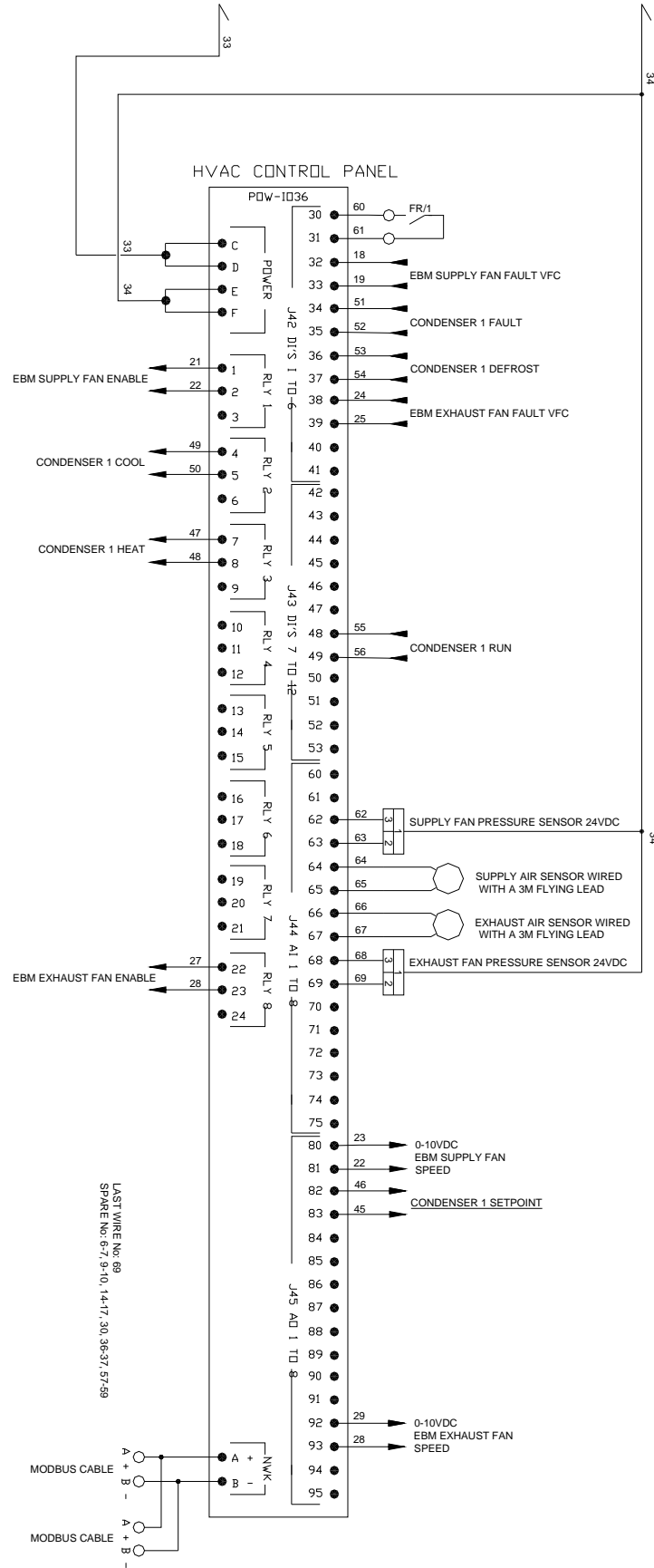

# 12. Wiring Diagrams cont.

## Schematic Wiring Diagram McDonalds IDF1DXHXPL UNIT

SHEET 4 OF 4

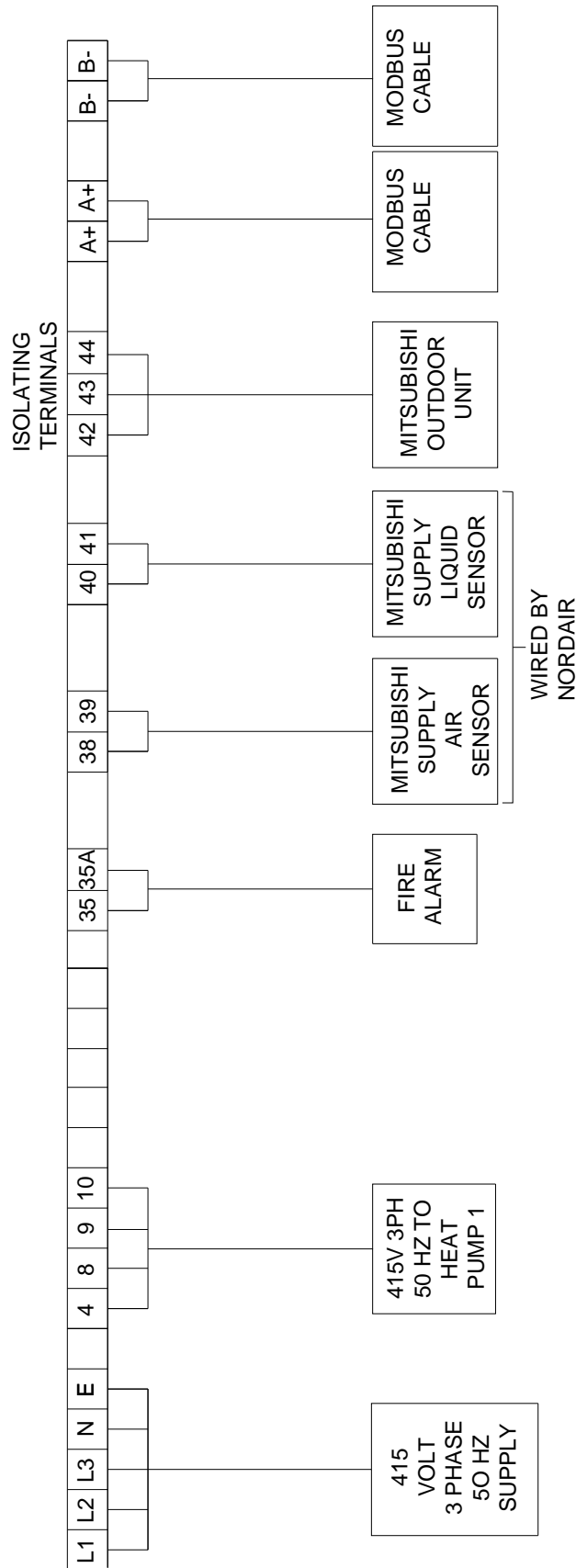

# 13. Fault Finding

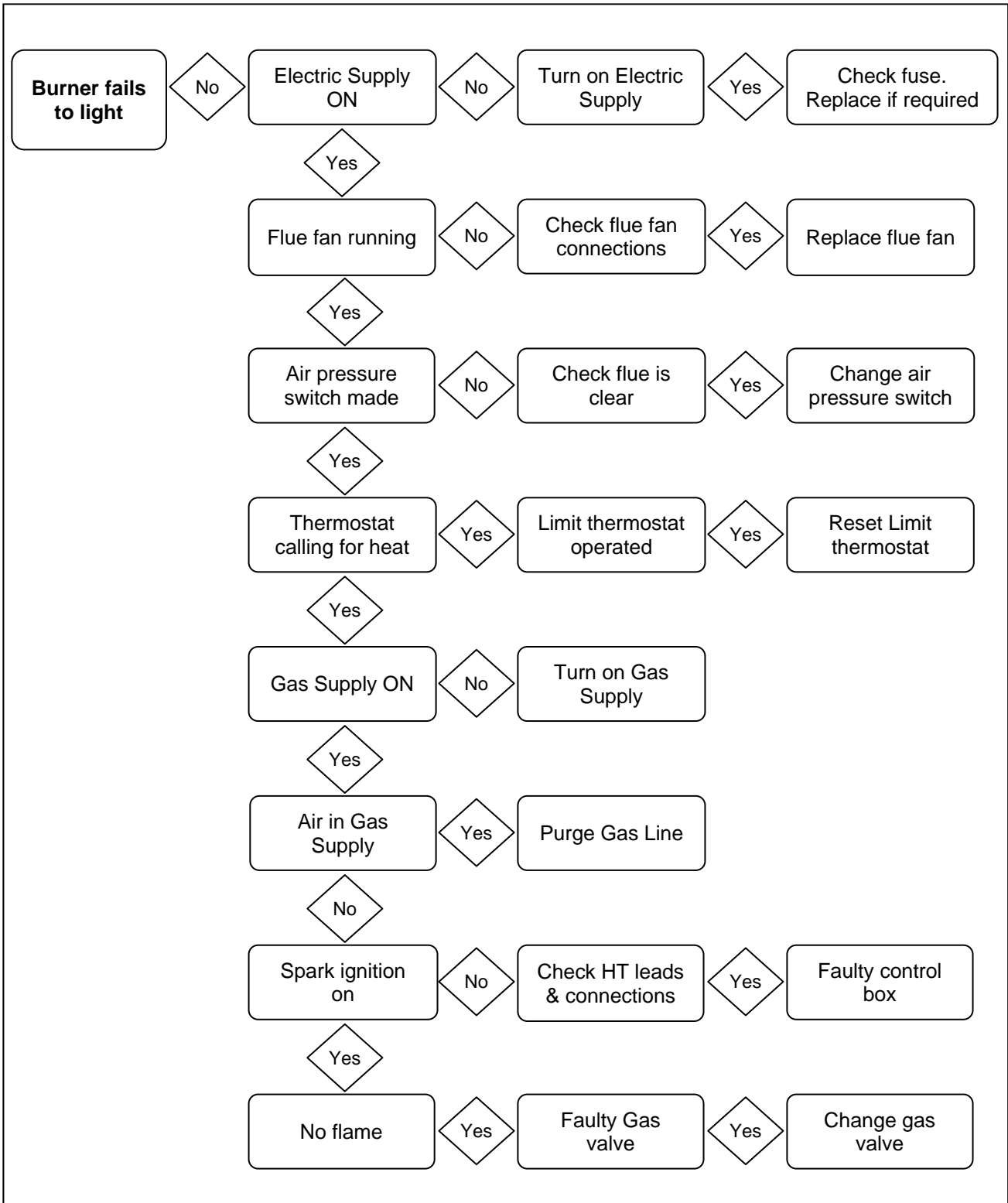

Document reference number: GENOR/100/0415



**NORTEK GLOBAL HVAC (UK) LTD**  
 Fens Pool Avenue  
 Brierley Hill  
 West Midlands DY5 1QA  
 United Kingdom

Tel: 01384 489 250  
 Fax: 01384 489 707  
 nordairnichesales@nortek.com  
 www.nordairniche.co.uk