

# UESA Series



CONDENSING GAS FIRED UNIT HEATERS



**REZNOR®**

# UESA Series

## CONDENSING GAS FIRED UNIT HEATERS



### Introduction

The new market leading UESA series of energy saving condensing gas fired unit heaters provides the highest efficiency levels and substantially reduced carbon dioxide emissions.

The units exceed the requirements of current Building Regulations L2, with thermal efficiencies up to 104% to provide exceptional levels of seasonal efficiency.

These 3rd generation units utilise corrosion resistant aluminium in the manufacture of the MacroChannel multipass heat exchanger and are up to 25% lighter than the previous condensing models.



### Features

- Up to 104% thermal efficiency
- Reduced CO<sub>2</sub> and NOx emissions
- Reduced energy bills
- Ideal for new low carbon buildings
- Up to 30% energy saving on replacement heaters
- Unique streamlined aerodynamic profile of the heat exchanger results in minimal resistance to airflow to give longer throws, improved air distribution and reduced temperature gradients to minimise energy consumption further
- Manufactured using high quality corrosion resistant materials, the non-welded design of the heat exchanger reduces thermal stress for enhanced life expectancy
- Advanced burner technology utilises a single self-aligning burner, with multi-try ignition for optimum reliability and ease of maintenance
- Versatile flue options for ease of siting
- Optional wireless control

### Model Range

The UESA condensing units are available with heat outputs ranging from 35kW-102kW for use on natural gas or propane.



## Advanced Heat Exchanger Technology

Superior heat exchanger using patented MacroChannel multipass heat exchanger technology offers optimum heat transfer.

As the flue gases pass through the heat exchanger the extra surface area and high thermal conductivity of the aluminium MacroChannel (many times greater than steel) cools the flue gases below 45°C causing the water vapour to condense and release its latent heat.

This heat, which would normally be lost to the atmosphere via the flue, is instead transferred into the building hence less fuel is used to achieve the same heat output.

The high efficiency levels are not dependent on the firing rate and the units are permanently condensing, with constant low flue gas temperatures.

## Optimum Economy and Fuel Savings

In times of rapidly increasing energy costs, reducing energy consumption makes sense both financially and environmentally since this also significantly reduces CO<sub>2</sub> emissions.

Although condensing air heaters require a higher initial capital investment they are very economical and can repay the extra initial cost in fuel savings in 2-4 years depending on usage.

When replacing traditional units more than 10 years old, savings of 30% can be achieved.

## Applications

- Automotive workshops
- Factories
- Retail outlets
- Sports facilities and halls
- Warehouses
- Workshops

## Comparative Energy Consumption

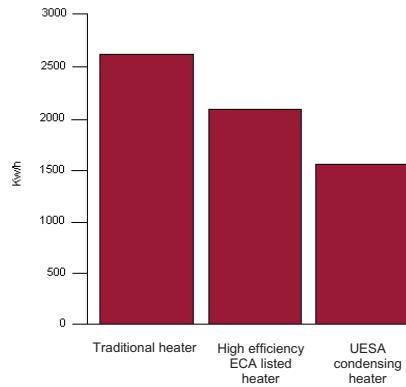

## Enhanced Capital Allowances (ECA)



The Government's Enhanced Capital Allowance scheme actively encourages industry and commerce to reduce energy consumption by promoting the use of energy efficient equipment. The high thermal efficiency of UESA units (up to 104%), significantly exceeds the 91% threshold for Enhanced Capital Allowances.



Authorised User No. 00182

This symbol verifies that the product has been independently assessed and qualifies for the ECA scheme, an upfront tax relief enabling businesses that invest in energy-saving equipment to claim 100% first-year capital allowances against their taxable profits.

# UESA Series

CONDENSING GAS FIRED UNIT HEATERS



## Specification

### Heat Exchanger

Manufactured using high quality corrosion resistant materials, the non-welded design of the heat exchanger reduces thermal stress for enhanced life expectancy.

The unique streamlined aerodynamic profile results in minimal resistance to airflow to give longer throws, improved air distribution and reduced temperature gradients to minimise energy consumption further.

### Dual Limit Stats

Dual limit stats provide additional safety and reliability.

### Traditional unit heater

Higher roof space temperatures increase heat loss through roof

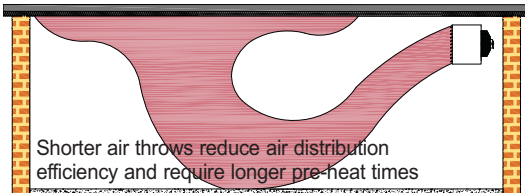

Shorter air throws reduce air distribution efficiency and require longer pre-heat times

### UESA heater

Reduced floor to ceiling temperature gradients

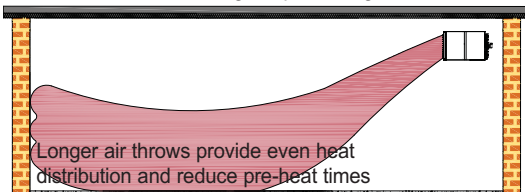

Longer air throws provide even heat distribution and reduce pre-heat times

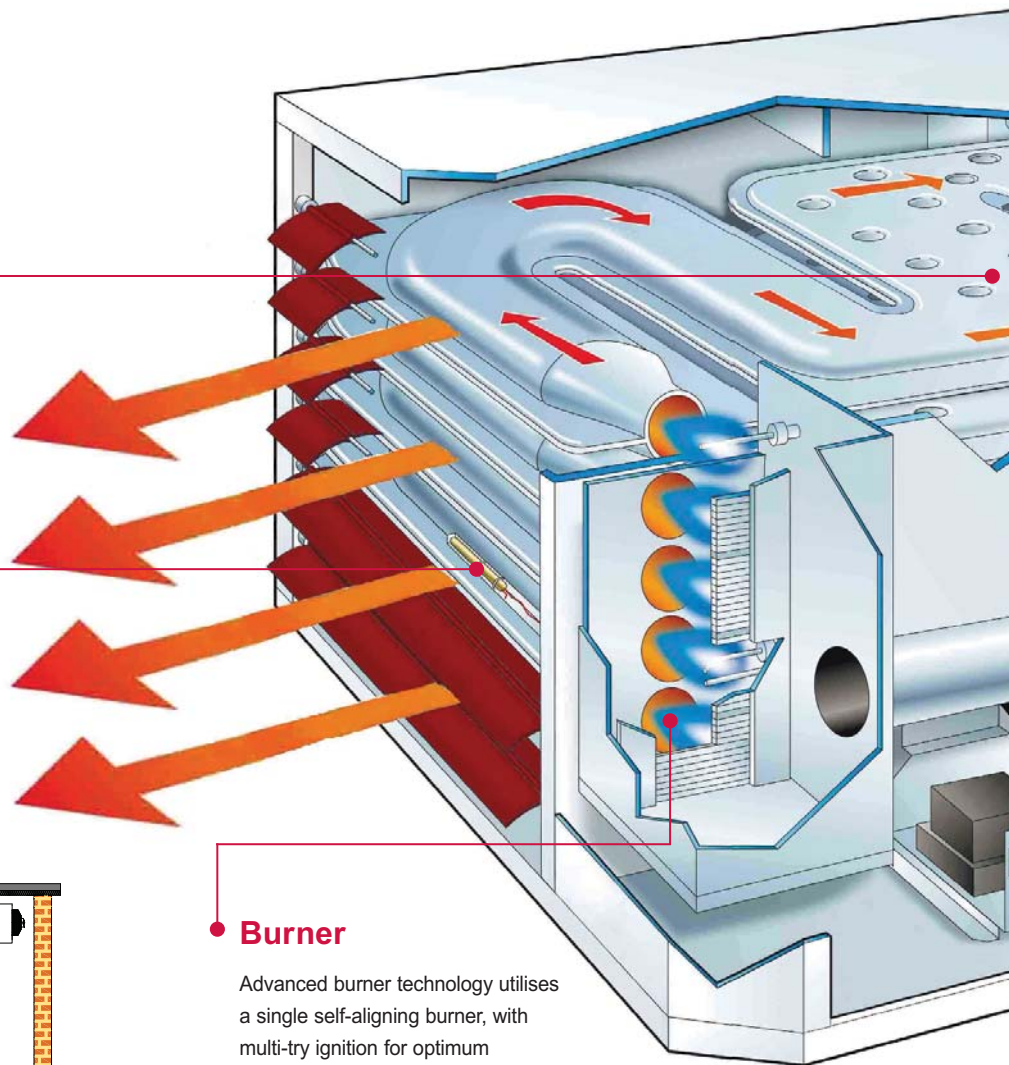

### Burner

Advanced burner technology utilises a single self-aligning burner, with multi-try ignition for optimum reliability and ease of maintenance.



## MacroChannel Heat Exchanger

The high thermal conductivity of the aluminium MacroChannel multipass heat exchanger maintains optimum efficiency at full heat output.

## Air Distribution

A high capacity axial flow fan is fitted to all units for improved air throws and reduced stratification.

The fan operation is controlled by an integral controller which delays the fan start up until the heat exchanger has reached operating temperature and continues to run the fan after the burner has switched off and all useful heat has been dissipated.

An optional economy thermostat may be fitted to heaters installed at high level to recirculate warm air down to working level when the burner is switched off.

## Condensate Drain

All units are supplied complete with condensate traps (loose) and condensate drain points to the heater and the flue.

## Venter fan

Aluminium corrosion resistant venter fan is housed in a separate compartment. Units are fully room sealed to prevent dirt or dust from entering the combustion system.

A differential pressure switch shuts down the unit in the event of inadequate combustion air, blocked flue or flue fan failure.

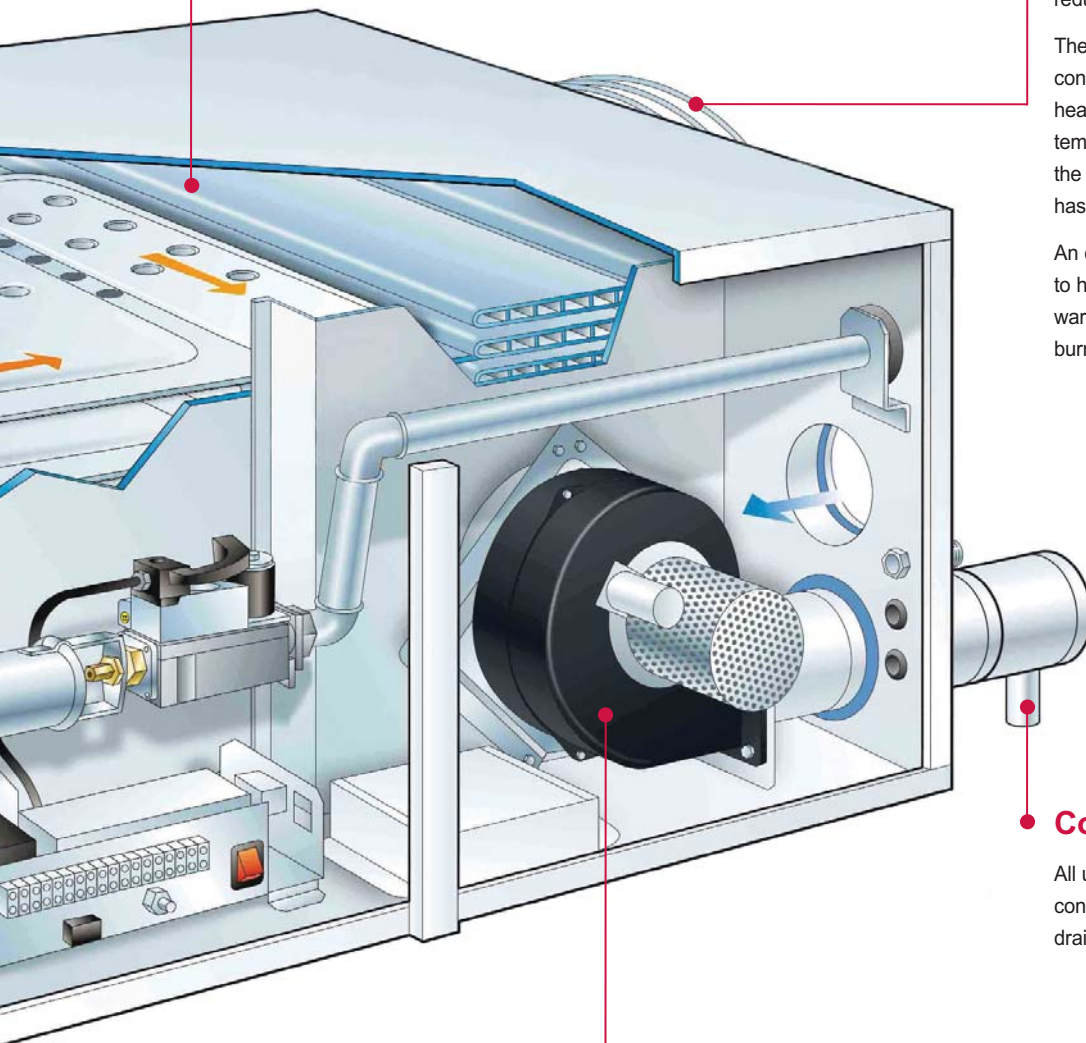

# UESA Series

## CONDENSING GAS FIRED UNIT HEATERS



### Installation

Units may be suspended or alternatively mounted on a suitable non-combustible support. Four integral suspension points complete with an M10 female thread are provided to each heater.

The balanced flue terminal provides both the combustion air inlet and flue outlet from a single building penetration. The terminals are ordered separately from the heaters to suit either a wall or roof outlet. Additional flue and combustion air pipes may be added, up to a maximum of nine metres of flue pipe, plus nine metres of combustion air pipe. (This reduces by 1.5 metres for every 90° bend fitted.)

To comply with CE approvals, balanced flue appliances must be used with the manufacturer's balanced flue system. The units are also certified for fan assisted flue installations, where the combustion air is to be drawn from within the heated space; an alternative wall or roof terminal is required for this application.

A single phase electrical supply is required to each unit. This supply should not be switched off except for maintenance.

Units must not be installed in atmospheres containing highly flammable or explosive vapours, combustible dust, halogenated hydrocarbons or chlorinated vapours. They are also unsuitable for areas where contaminants may affect electrical motors or connections.

A condensate drain must be installed in accordance with local regulations. Condensate traps are supplied with each heater, additional pipework must be supplied by the installer.

### Enhanced Reliability and Safety

A microprocessor burner control provides full safety monitoring and multi-try ignition control for enhanced reliability.

Limit stats monitor the operating temperature within the heater unit and shut down the burner in the event of overheating. For additional safety all models are fitted with dual limit stats.

A differential pressure switch shuts down the unit in the event of inadequate combustion air, blocked flue or flue fan failure.

### Ease of Maintenance

All controls are accessible from a single side and are housed behind a hinged door, situated on the left hand side of the unit when viewed from the rear. The hot gas exhaust fan is housed in a separate adjacent compartment.

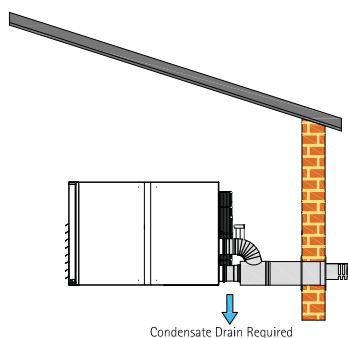

Balanced flue wall outlet (type C12) eliminates expensive roof opening and flashing

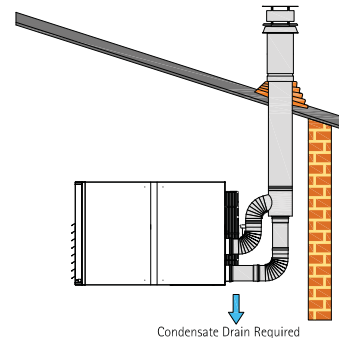

Balanced flue roof outlet (type C32)

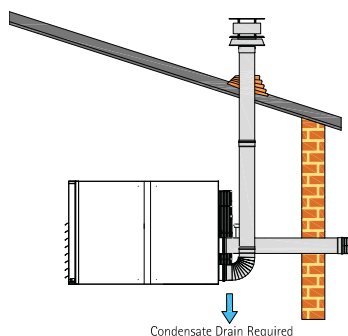

Combustion air through the wall, flue outlet through the roof (type C52)

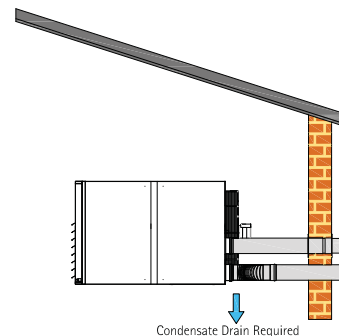

Separate combustion air and flue pipes (type C12) for applications where wall thickness exceeds 350mm. Flue and air intake to be offset

Heater positions and flue arrangements are indicative. For heater and flue clearances please refer to the manufacturer's guidelines.

## Additional Control at the Touch of a Button

To complement the high efficiency UESA units a versatile range of SmartCom control panels are available.

- Self adapting optimum start and stop
- Simple user-friendly programming
- Individual seven day programming
- Day, night and frost (5°C) temperature settings
- Three on/off periods per day
- Easy set overtime and holiday periods
- Remote burner reset facility
- Password protection to prevent unauthorised adjustment
- Hours run and service data logging
- Battery back up in the event of mains failure
- High / Low or modulating burner control (Multi-zone version required)

## Multi-zone Control

Allows up to 16 units to be centrally controlled. Functions controlled by the master unit include:

- Clock updating
- Updating temperature functions and programme settings
- Viewing the room and set temperature settings of all units
- Setting holiday, overtime and vent only functions for the entire network
- Centralised burner lock out reset



## Wireless Control

Alternatively the UESA units may also be supplied with wireless controls which completely eliminate on-site control wiring for substantially reduced electrical installation costs.



TECHNICAL DATA				UESA 35	UESA 55	UESA 83	UESA 102
Model							
Nominal heat output	kW		35	55	83	102	
Airflow	m <sup>3</sup> /h		3900	5900	9060	10570	
Temperature rise	°C		26	27	27	28	
Throw <sup>1</sup>	m		28	36	41	44	
Noise level (free field @ 5m)	dB(A)		45	52	52	51	
Noise level (typical installation @ 5m)	dB(A)		52	59	59	58	
Gas consumption <sup>2</sup>	Natural gas G20	m <sup>3</sup> /h	3.60	5.60	8.40	10.30	
	Propane G31	kg/h	2.60	4.10	6.20	7.50	
	Gas connection <sup>3</sup>	Rc	¾"	¾"	¾"	¾"	
Mounting height <sup>4</sup>	m		3.0 - 3.5	3.0 - 4.0	3.0 - 4.0	3.5 - 4.5	
Total electrical load (230V/50Hz)	kW		0.62	0.81	0.99	1.30	
Net weight	kg		148	151	222	230	

1 Throw is dependent on mounting height, building height, room temperature and louvre settings.

2 Natural gas G20 Calorific value 10.48kW/m<sup>3</sup> GCV, inlet gas pressure maximum 50mbar, minimum 17.5mbar.  
Propane G31 Calorific value 14.0kW/kg GCV, inlet gas pressure maximum 50mbar, minimum 37mbar.

3 Not supply line size.

4 Recommended height to underside of heater for standard horizontal discharge units. Downturn nozzles are recommended for units installed at higher mounting heights. For buildings over 4 metres high, air re-circulation fans are recommended in conjunction with the heaters.

## DIMENSIONS

Model		UESA 35	UESA 55	UESA 83	UESA 102
Height	A	510	510	866	866
Overall length	B	1512	1512	1520	1520
Base to gas inlet	C	366	366	441	411
Base to air inlet	D	252	252	324	324
Base to flue outlet	E	112	112	99	99
Side to air inlet and flue outlet	F	192	192	190	190
Flue and combustion air collars		100	100	130	130
Top clearance		100	100	100	100
Rear clearance		450	450	450	450
Bottom clearance*		100	100	100	100
Side clearance		100	100	100	100
Service panel clearance		700	700	700	700

\*Heaters can be base mounted on adequate non-combustible supports.

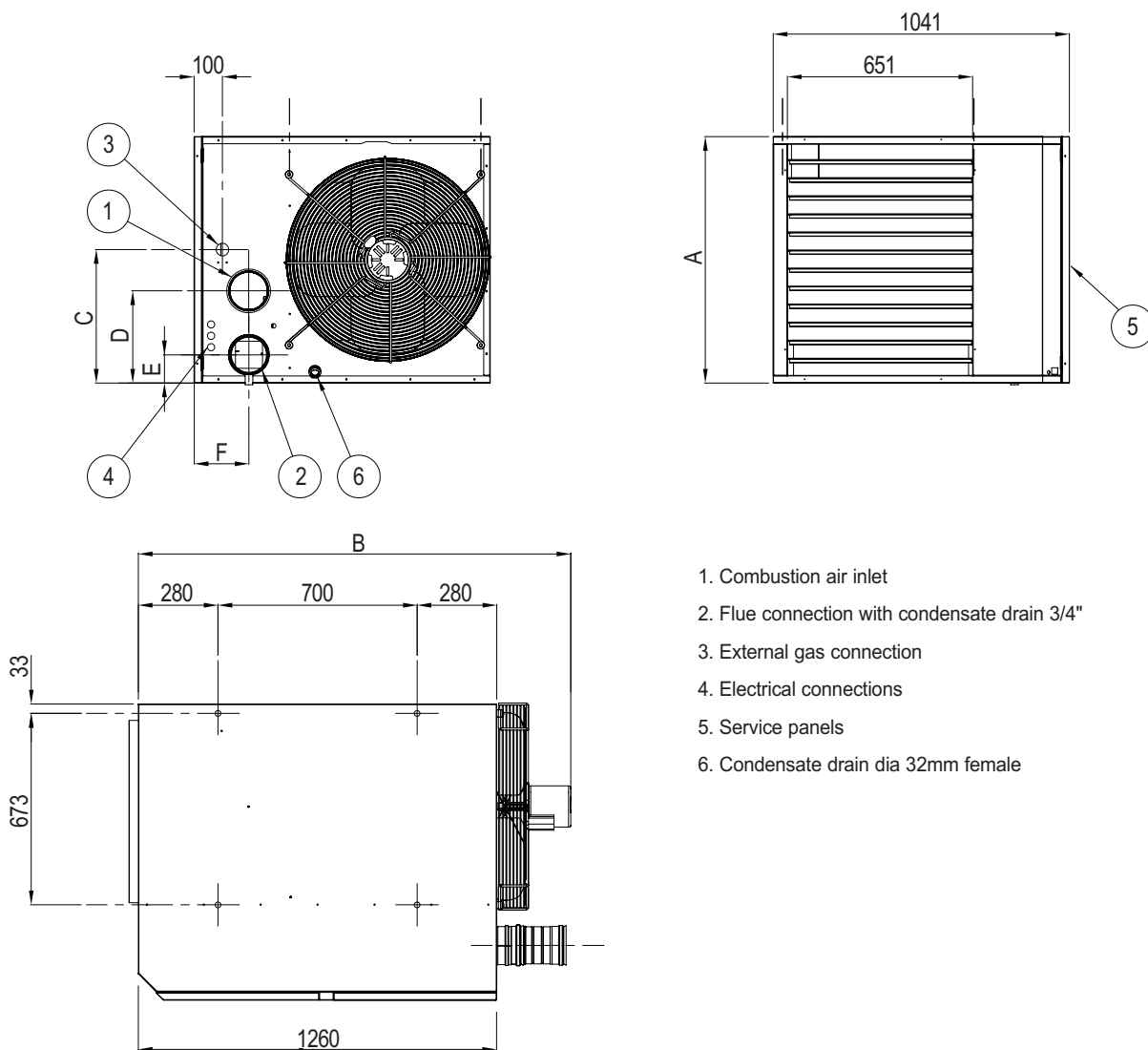

1. Combustion air inlet
2. Flue connection with condensate drain 3/4"
3. External gas connection
4. Electrical connections
5. Service panels
6. Condensate drain dia 32mm female

An AmbiRad Group brand

# REZNOR®

Reznor UK is a registered trademark of AmbiRad Limited. Because of continuous product innovation, AmbiRad reserves the right to change product specification without due notice.



Reznor UK Limited Park Farm Road Folkestone  
Kent CT19 5DR United Kingdom



Telephone: 01303 259141  
Facsimile: 01303 850002  
Email: [marketing@reznor.co.uk](mailto:marketing@reznor.co.uk)  
Website: [www.reznor.co.uk](http://www.reznor.co.uk)