

NOR-RAY-VAC MODULATING CONTINUOUS RADIANT TUBE SYSTEM

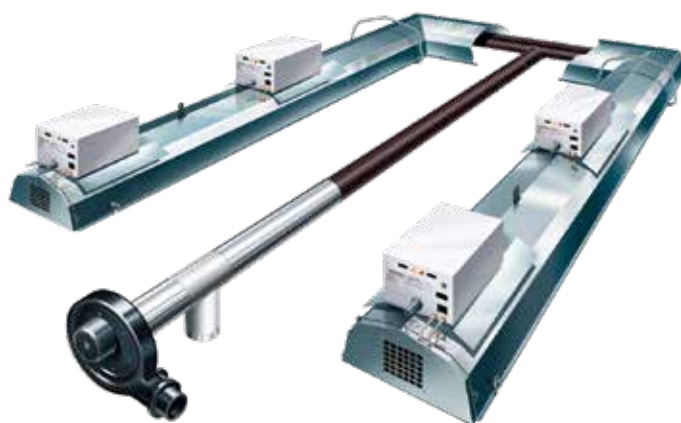

INSTALLATION MANUAL



WARNINGS

Nortek Global HVAC (UK) Limited equipment must be installed and maintained in accordance with the requirements of the Codes of Practice or rules in force. All external wiring MUST comply with the codes of practice or rules in force in the country of installation.

Improper installation, adjustment, alteration, service or maintenance can cause property damage, injury or death.

Read instructions before installing or servicing this equipment. Gas-fired appliances are not designed for use in hazardous atmospheres containing flammable vapours or combustible dust, containing chlorinated or halogenated hydrocarbons, or in applications with airborne silicone substances.

Reznor® is a registered trademark of Nortek Global HVAC, LLC.

Any reference made to Laws, Standards, Directives, Codes of Practice or other recommendations governing the application and installation of heating appliances and which may be referred to in Brochures, Specifications, Quotations, and Installation, Operation and Maintenance manuals is done so for information and guidance purposes only and should only be considered valid at the time of the publication. The Manufacturer cannot be held responsible from any matters arising from the revision to or introduction of new Laws, Standards, Directives, Codes of Practice or other recommendations.

IMPORTANT NOTICE TO INSTALLERS

Installers should satisfy themselves that the gas pipework installation is carried out in accordance with all current legislation, Codes of Practice and recommendations .

Additionally it may be necessary to protect the gas valves which form part of the heater or burner assembly from potential pipe contamination particularly, but not exclusively, where copper gas pipework is used.

In instances where copper pipework is to be used for all or part of a gas pipework installation, including short length final connections then we advise that installers consult with gas supplier or provider and satisfy themselves what additional precautions may be necessary.

Document Index.

1 Installation Requirements

- 1.1 Compliance Notices
- 1.2 Certificate of Conformity
- 1.3 General Product Information
- 1.4 Model Definitions
- 1.5 General requirements
- 1.6 Delivery and Pre-Installation Checks
- 1.7 Health & Safety
- 1.8 Heater Suspension
- 1.9 Clearance to Combustibles
- 1.10 Gas Connection & Supply Details
- 1.11 Electrical Connections
 - 1.11.1 Typical Wiring Schematic
 - 1.11.2 Wiring Details
- 1.12 Ventilation Requirements
- 1.13 Flue System
 - 1.13.1 General
 - 1.13.2 Flue Installation
 - 1.13.3 Exhaust Considerations
 - 1.13.4 Ducted Air Considerations
- 1.14 Vacuum Fan Details
- 1.15 Technical Data

2 Assembly Instructions

SEE BOOKLET 2, DOCUMENT REF 700071

3 Commissioning Instructions

- 3.1 Tools Required
- 3.2 General
- 3.3 Commissioning Procedure
 - 3.3.1 Start Up Checks
 - 3.3.1.9 Burner Timer Dip-switch Settings
- 3.4 Schneider Inverter Driven Mod Fans B80, B160, B300
- 3.5 Schneider Inverter Driven Fans B80, B160, B300 Mod Branch Damper (Zonal Modulation)
- 3.6 ABB Inverter Driven BH300 Mod Fan
- 3.7 ABB Inverter Driven Fan BH300 Mod. Branch Damper (Zonal Modulation)
- 3.8 Damper Setup
- 3.9 Non-inverter Driven Fans, Mod Branch Dampers (Zonal Modulation)
- 3.10 Non-inverter Driven Fans Mod Fan Damper (System Modulation)
- 3.11 Final Commissioning
 - 3.12.1 System Layout via 1ph Inverter
 - 3.12.2 System Layout via Zonal Branch Damper
 - 3.12.3 System Layout via System Fan Damper

4 Servicing Instructions

- 4.1 Tools Required
- 4.2 Burner Exploded Views
- 4.3 Vacuum Fan
- 4.4 Radiant Tubes
- 4.5 Tube Couplers
- 4.6 Reflectors
- 4.7 Flue Condensate Trap
- 4.8 Burner Electrode Assembly
- 4.9 Burner Head
- 4.10 Filter
- 4.11 Combustion Chamber Viewing Window
- 4.12 Flue Assembly

5 Spare Parts

- 5.1 Required Spares List
- 5.2 Injector/Air Shutter Selection

6 Fault Finding Guide

7 Replacing Parts

- 7.1 Removal of Burner Assembly
- 7.2 Controller Replacement
- 7.3 Gas Valve Replacement
- 7.4 Filter Replacement
- 7.5 Pressure Switch Replacement
- 7.6 Electrode Assembly Replacement
- 7.7 Injector Replacement
- 7.8 Combustion Chamber Window Replacement

8 User and Operating Instructions

- 8.1 To Start Heater
- 8.2 To Switch Off the Heater
- 8.3 Routine Maintenance Between Service Intervals
- 8.4 Frequency of Servicing

Introduction.

Welcome to the range of Nor-Ray-Vac 'M' series modulating continuous radiant tube heaters. The Nor-Ray-Vac 'M' series modulating system complies with the requirements of the European Gas Appliance Regulation and BS EN 17175. Local regulations may vary in the country of use and it is the installers responsibility to ensure that such regulations are satisfied.

All installation, assembly, commissioning and service procedures must be carried out by suitable qualified competent persons to the statutory regulations in the country of use.

When assembling, installing, commissioning and servicing is undertaken on radiant tube heaters specified in these instructions, due care and attention is required to ensure that working at height regulations are adhered to at the mounting heights specified.

 **PLEASE READ** this document prior to installation and use. The safety of this heater is guaranteed only by the correct usage in accordance with these instructions, therefore it is recommended that they are retained for future reference.

All Dimensions shown are in mm unless otherwise stated.

The manufacturer reserves the right to alter specifications without prior notice.

1. Installation Requirements.

 Isolate any electrical supply to the heater and controller before proceeding.

1.1 Compliance notices

The Nor-Ray-Vac 'M' series detailed herewith is manufactured within a strictly controlled quality environment within the parameters of ISO 9001.

These instructions are only valid if the following country code is on the appliance GB. IE. If this code is not present on the appliance, it is necessary to refer to the technical instructions which will provide the necessary information concerning the modification of then appliance to the conditions of use for the country.

The Nor-Ray-Vac 'M' series has been tested and assessed for compliance with the following European Directives.

- * Gas Appliances Regulations (EU) 2016/426
- * Eco-Design Directive (2009/125/EC)
- * Machinery Directive: (2006/42/EC)

- * Low Voltage Directive: (2014/35/EU)
- * Electromagnetic Compatibility Directive: (2014/30/EU)
- * Product Liability Directive: (85/374/EEC)
- * The Product Safety and Metrology etc. (Amendment etc.) (EU Exit) Regulations 2020 (SI 2020/676)

The manufacturer has taken reasonable and practical steps to ensure that the Nor-Ray-Vac 'M' series modulating system is safe and without risk when properly used. These heaters should therefore only be used in the manner and purpose for which they were intended, and in accordance with the recommendations detailed herewith.

The heaters have been designed, manufactured, assembled, inspected, and tested, with safety and quality in mind, there are certain basic precautions which the installer and user should be aware of, and they are strongly advised to read the appropriate sections of the information pack accompanying the heater, prior to installation or use.

The Manufacturer supports all new products being supplied to their customers with a comprehensive information pack; this clearly defines mandatory instructions for the safe installation, use, and maintenance, of the appliance(s).

Where proprietary items are incorporated into Nor-Ray-Vac 'M' System, detailed information and instructions are also provided as part of the information pack.

It is the responsibility of the installer, owner, user, or hirer, of the Nor-Ray-Vac 'M' Systems, to ensure that they are familiar with the appropriate information/manuals, supplied by the manufacturer, and that they are suitably aware of the purpose of the manuals and the safety instructions. In addition, operators must be suitably trained in the use of the appliance so as to ensure its continued safe and efficient use.

The Manufacturer has a commitment to continuous improvement and therefore reserves the right to amend or change the specification of the Nor-Ray-Vac 'M' series subject to compliance with the appropriate European, national, and local regulations.

Contained within the text of the manual, the words 'Caution' and 'Warning' are used to highlight certain points.



Caution is used when failure to follow or implement the instruction(s) can lead to premature failure or damage to the heater or its component parts.



Warning is used when failure to heed or implement the instruction(s) can lead to not only component damage, but also to a hazardous situation being created where there is a risk of personal injury.

The Nor-Ray-Vac 'M' series conforms to the following harmonised standards:

BS EN 292 -1

Safety of Machinery - Basic Concepts, General Principles for Design Basic terminology, methodology BS EN 292-2.

Safety of Machinery - Basic Concepts, General Principles for Design Technical Principles and Specifications.

BS EN 60204-1

Safety of Machinery - Electrical Equipment for Machines Specification for General Requirements.

BS EN 60335-1

Safety of Household and Similar Electrical Appliances General Requirements

BS EN 55014

Limits and methods of measurement of radio disturbance characteristics of electrical motor-operated and thermal appliances for household and similar purposes, electrical tools and similar electric apparatus.

BS EN 50165

Electrical Equipment of non-electric heating appliances for household and similar purposes, safety requirements.

1.2 Certificates of conformity

Certificates are available from the manufacturer, address details are shown on the back page.

1.3 General product information

The Nor-Ray-Vac 'M' series radiant heating system comprises of a modulating continuous system with a number of burners located in series in a radiant branch, and a number of radiant branches manifolded together, linked by a tail pipe to a vacuum fan discharging the spent products of combustion to atmosphere. A system may comprise of just one burner and one vacuum fan, to multiple burners in multiple radiant branches with one or more vacuum fans.

To enable exact matching of operational needs within an area, distances between burners and ratings of the burners can vary. The unique feature of Nor-Ray-Vac 'M' series is a modulating radiant system which provides uniform heat coverage of the floor area, eliminating hot/cold spots.

The tube into which the burners are mounted and over which the reflectors are fitted and emits the maximum heat is called the radiant tube. The radiant heat emitted from the

hot tube is directed downwards by reflectors. The remaining interconnecting tube is called the tail pipe and radiates with less intensity.

The operating temperatures of the tubes generally range from 200°C – 480°C max.

The action of the vacuum fan is three fold; to create a high negative pressure within the radiant tube and tail pipe so as to discharge the spent products of combustion from the system to a point outside the building being heated; to control the flow of gas and air through each burner in stoichiometric proportions; to draw carrier air into the tube system at the start of each radiant branch, in order to distribute the heat from the flame along the tube.

Ducted air inlet kits are also available for contaminated or dusty environments.

Each heater is fitted with a burner which has been test fired and pre-set prior to despatch. The safety functions of the burner are by way of a fully sequential control box fitted to the burner.



Note

Neither asbestos nor soft soldered joints are used in the construction or manufacture of the Nor-Ray-Vac 'M' series. The materials selected for use can withstand the mechanical, chemical, and thermal stresses which they will be subject to during foreseen normal use when installed in accordance with the manufacturers recommendations.

1.4 Model Definitions

NRVxxM-EV = Nor-Ray-Vac modulating continuous radiant tube heater only for use with branch end configurations.

NRVxxM-IL = Nor-Ray-Vac modulating continuous radiant tube heater only for use with in-line configurations.

xx denotes kW rating. Models available; 24, 32, 38 and 46

1.5 General requirements



Caution

Before installation, check that the local distribution conditions, nature of gas and pressure, and adjustment of the appliance are compatible.

 **Installation and assembly procedures must be carried out by suitable competent persons. Commissioning and service procedures must be carried out by suitable qualified persons.**

 **Warning**

Unauthorised modifications to the appliance, or departure from the manufacturers guidance on intended use, or, installation contrary to the manufacturers recommendations may constitute a hazard.

The Nor-Ray-Vac system as designed and supplied shall not be altered without consultation and approval from Nortek Global HVAC (UK) Limited.

 **Note**

To ignore the warning and caution notices, and to ignore the advice from the manufacturer on installation, commissioning, servicing, or use, will jeopardise any applicable warranty, moreover, such a situation could also compromise the safe and efficient running of the appliance itself, and thereby constitute a hazard.

The installation of the appliance must meet all the relevant European, national, and local criteria.

Prior to installation the following points should be considered;

- * The position of the heater for the optimum efficient distribution.
- * The position of the heater relative to the route of the flue.
- * The position of the heater relative to the supply of gas.
- * The position of the heater relative to the electrical services, and if appropriate, any additional controls.
- * The position of the heater relative to the supply of fresh air if applicable.
- * The position of the heater relative to service and maintenance requirements.

 **Caution**

The heater must not be installed within an area where the conditions are unsuitable, e.g. where the atmosphere is highly corrosive, has a high degree of salinity, or where high wind velocities may affect burner operation. Suitable protection should be provided for the appliance when it is located in a position where it may be susceptible to external mechanical damage from; for example, fork lift trucks, overhead cranes etc.

1.6 Delivery and pre-installation checks.

On receipt of the heater, the following checks should be carried out;

- * The model is as per order.
- * That it is undamaged.
- * That it is suitable for the fuel supply.
- * That it is suitable for the electrical supply.

If any of these points are not satisfied then contact should be made with the Sales Office at Nortek Global HVAC (UK) Limited as soon as possible by telephoning 01384 489250. In the case of claims for damage, this must be signed for as damaged and reported in writing within 24 hours of delivery, in order to comply with insurance criteria.

1.7 Health and Safety

 **Warning**

Nor-Ray-Vac 'M' series must be installed in accordance with the relevant provisions of the Gas Safety (Installations and Use) Regulations 1998. Due account should also be taken of any obligations arising from the Health and Safety at Works Act 1974 or relevant codes of practice. In addition the installation must be carried out in accordance with the current IEE wiring regulations (BS 7671), BS 6896: (Industrial & Commercial) and any other relevant British Standards and Codes of Practice by a qualified installer. Isolate all electrical supplies to the heater & controller before proceeding.

 **Caution**

For your own safety we recommend the use of Personal Protective Equipment during installation.

1.8 Heater Suspension

First considerations

Clearances from combustibles must be maintained. (See fig 2).

For ease of servicing there should be a minimum clearance distance of 500mm between the burners of the heating system and the building wall. This measurement can be reduced for perimeter type systems. (See figure 1a). For ease of servicing and burner removal minimum clearances should be maintained. (See figure 1b and 1c). In exceptional circumstances the burner lid may be slid diagonally for removal thus reducing the vertical distance.

Ensure that the suspension is sufficiently flexible to allow for thermal expansion.

Suspending the heater - General

The first support is always positioned at the support lug suspension point on the end vent burner combustion chamber.

Subsequent supports are placed approximately 2.8m apart, including one at each combustion chamber location. This gives a maximum load per support of 24kg.

A support must always be located at a maximum distance of 2m from a tee or elbow fitting.

Except for the combustion chamber support lug suspension points, suspension support brackets are installed to support the tube section which is then covered with reflectors.

Tail pipe hangers are installed for the tube section which will be without reflectors.

If there are any doubts as to the strength or suitability of roof steelwork to which heaters are to be suspended, please refer to a Consultant, Architect or owner of the building.

The manifold should be supported by chain, stainless steel

flexible wire, or other flexible means from the roof structure to allow movement caused by thermal expansion. The maximum distance between supports is 1.5m for horizontal runs.

Wall bands are not load bearing and give lateral support only. If used, wall bands should be fitted every 3m on vertical runs to ensure the system is rigidly held. The system should be braced immediately below passing through the roof line to ensure the flashing does not suffer lateral pressures.

Table 1. Minimum mounting heights

The recommended mounting heights for Nor-Ray-Vac 'M' heaters are given in the table below.

Recommended Mounting Height (m)	
Model	Horizontal
NRV24M	4.0M
NRV32M	4.7M
NRV38M	5.7M
NRV46M	6.0M

fig. 1.a Overall dimensions

- A** Burner Tube
- B** Burner
- C** *Optional Perimeter Reflector*
- D** Side wall

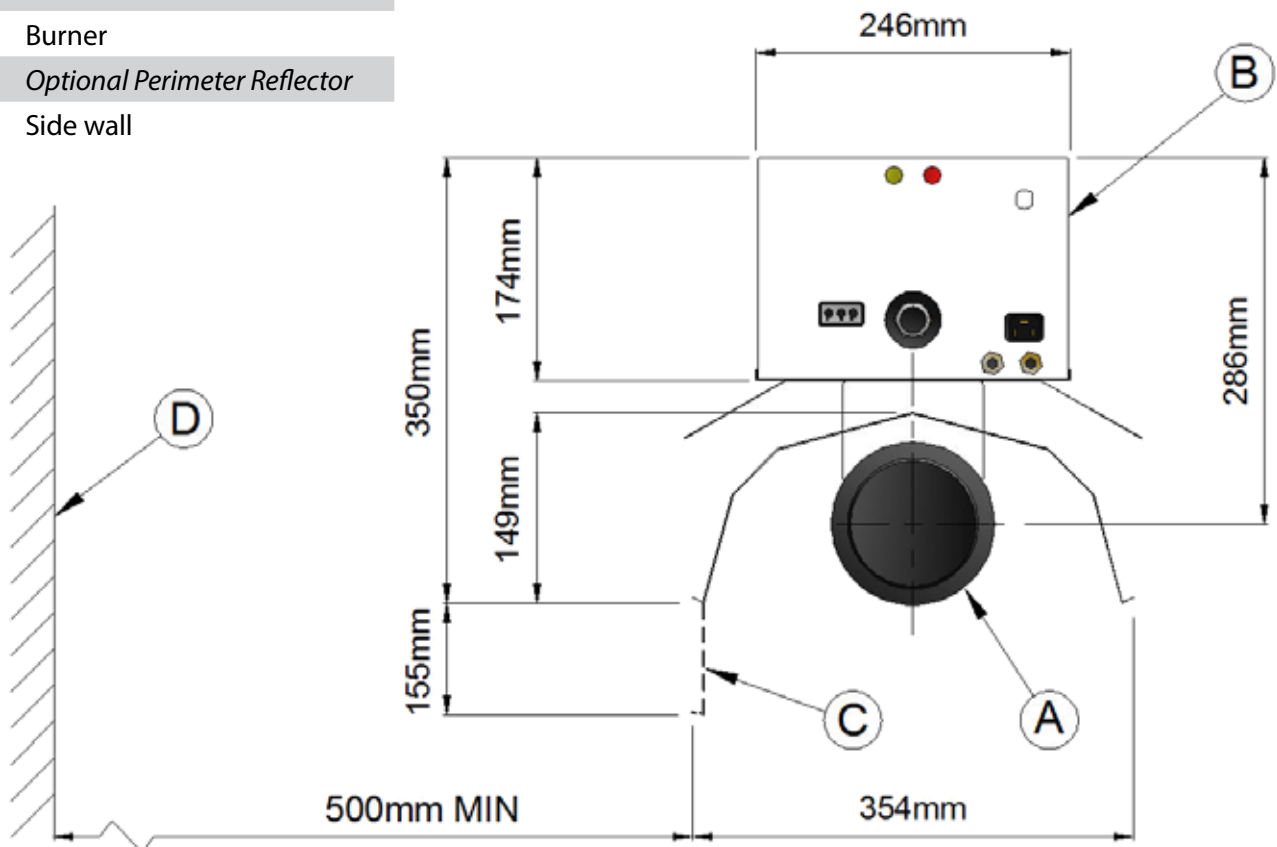

fig. 1.b Clearance for servicing - distances to walls and obstacles above.

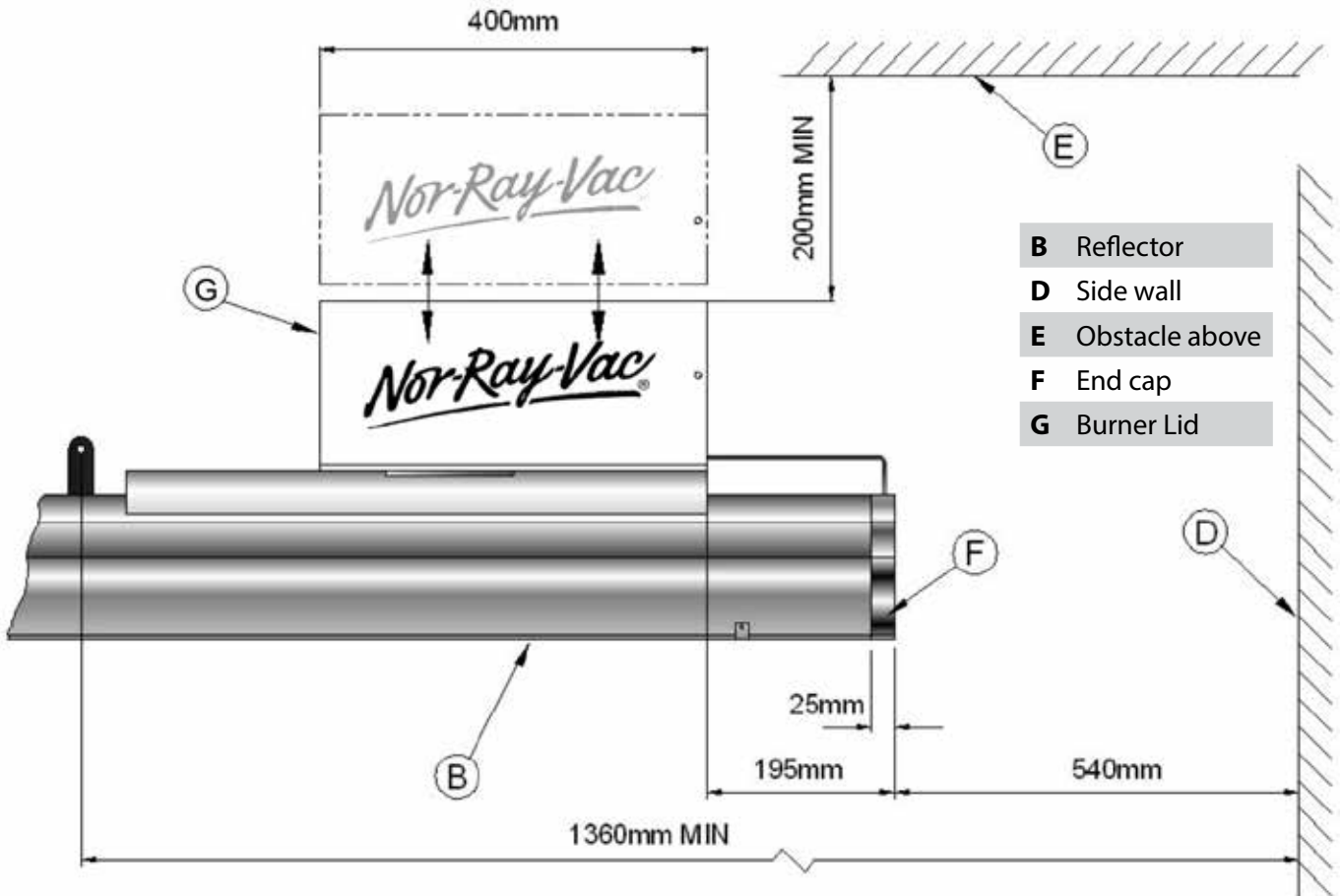
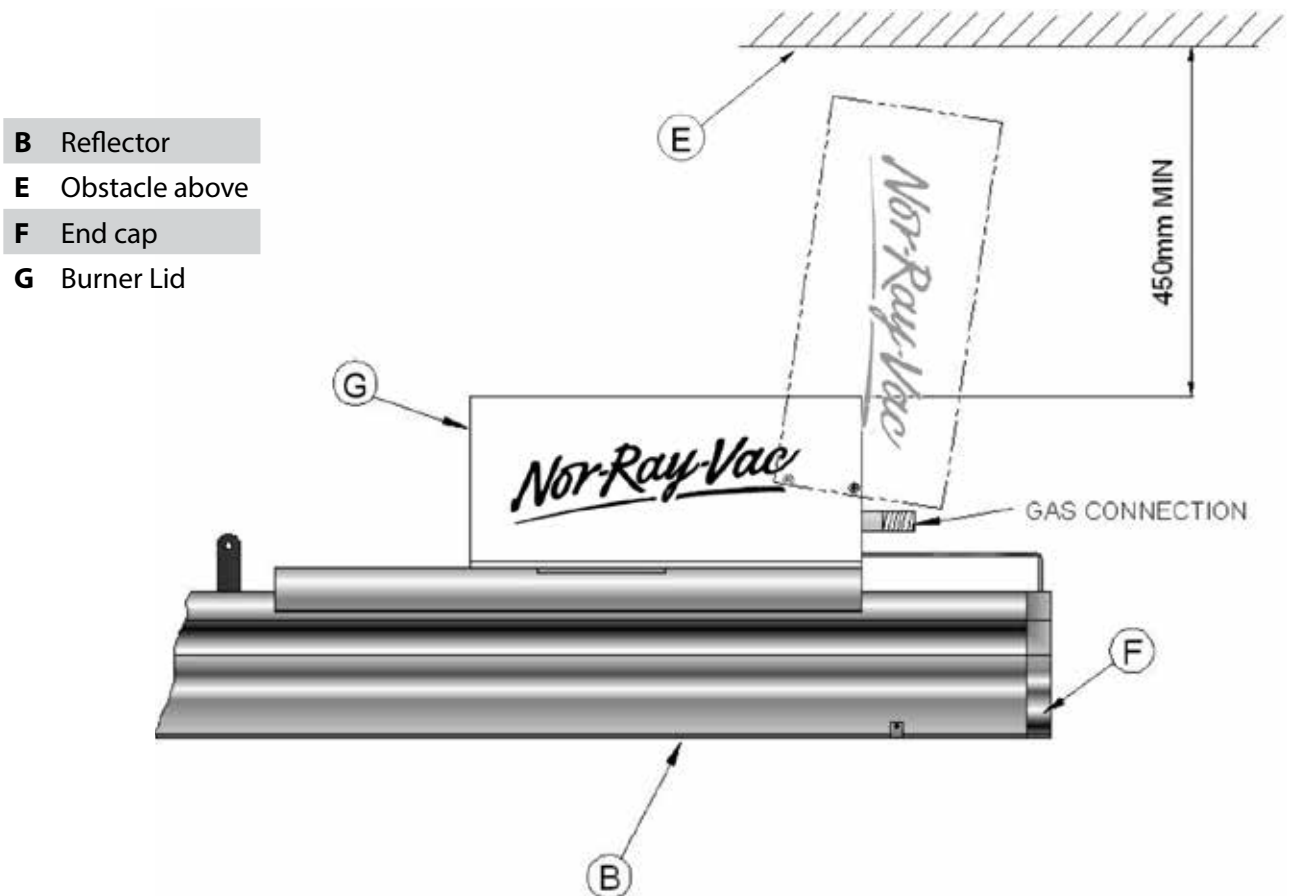

fig. 1.c Clearance for servicing - distances to obstacles above.



1.9 Clearance to Combustibles.

The minimum clearances to combustible materials are given below. These minimum distances MUST be adhered to at all times

Figure 2 Diagram illustrating the clearance to combustibles

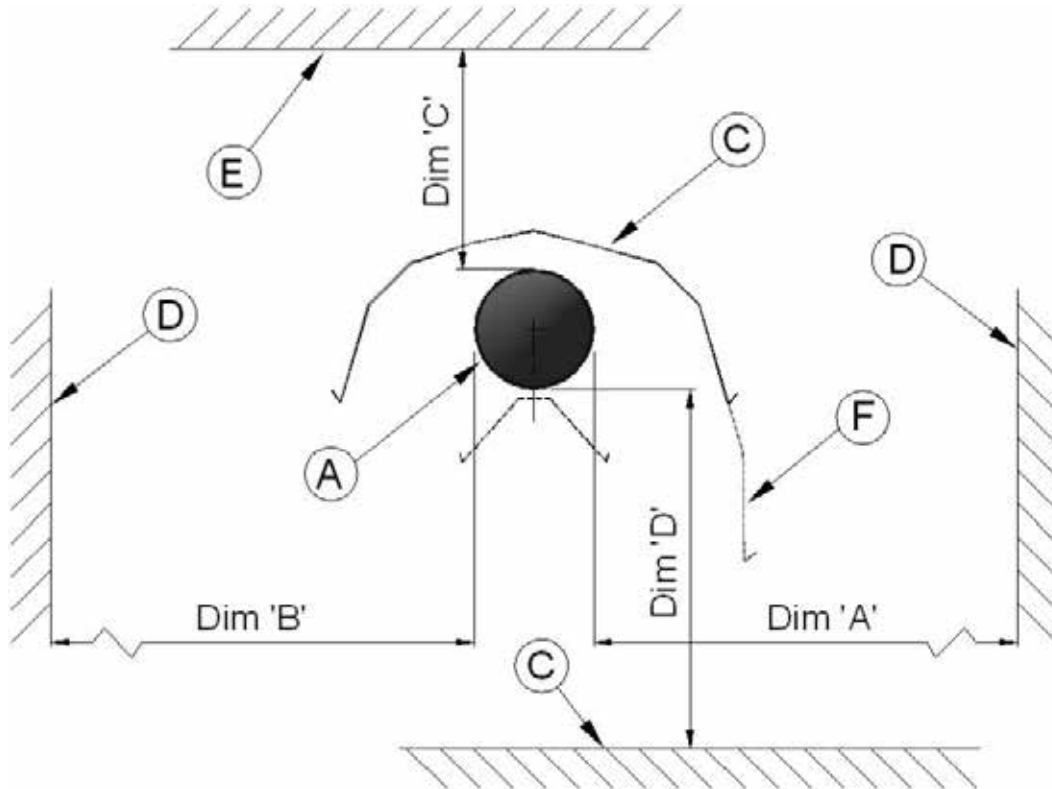

Distance from combustibles (distance from heat source that will produce a 50°C rise in temperature above ambient of a black surface)
 A Radiant tube; B Standard reflector; C Combustibile material underneath; D Combustibile material on side; E Combustibile material above; F Perimeter reflector;

Burner Model	NRV24M		NRV32M	
	End Vent	In-line	End Vent	In-line
Below tube				
Dim D - without undershield	1120	1250	1440	1700
Dim D - with undershield	760	850	760	850
Dim C - above tube	250	250	250	250
Horizontally				
Dim B - standard reflector	600	770	700	850
Dim A - perimeter reflector	305	450	305	510
Burner Model	NRV38M		NRV46M	
	End Vent	In-line	End Vent	In-line
Dim D - without undershield	1570	2100	1700	2100
Dim D - with undershield	785	1050	850	1050
Dim C - above tube	250	250	250	250
Horizontally				
Dim B - standard reflector	700	1000	700	1000
Dim A - perimeter reflector	305	600	305	600

1.10 Gas Connection and Supply

! Before installation, check that the local distribution conditions, nature of gas and pressure, and adjustment of the appliance are compatible.

! A competent or qualified engineer is required to either install a new gas meter to the service pipe or to check that the existing meter is adequate to deal with the rate of gas supply required.

! Installation pipes should be fitted in accordance with BS 6896, so that the supply pressure, as stated in Table 3 will be achieved. It is the responsibility of the competent engineer to ensure that other relevant Standards and Codes of Practice are complied with in the country of installation. Pipes of smaller size than the heater inlet gas connection must not be used. The complete installation must be tested for soundness as described in the country of installation.

! A gas isolation valve must be fitted immediately adjacent to each burner unit which, when closed, allow the complete burner unit to be disconnected for maintenance or repair.

i Take care when making a gas connection to the heater not to apply excessive turning force to the internal controls.

! A flexible hose is installed to allow safe linear expansion to each burner without creating undue stress on the gas supply pipe work. It is therefore important that a tested and certified hose assembly made to ISO 10380, supplied with ½" BSP female cone seat adapters, is installed as per these instructions.

! It is also important to ensure that expansion is taken up in the body of the flexible hose, and not on its attachment to the pipe work.

The cone seat adapter supplied on one end of the flexible gas hose provides a 'swivel' action, and must be fitted on the burner using a ½" BSP barrel nipple to provide ease of disconnection for future servicing.

i The installation layout described below is the only method recommended by the institute of gas engineers, the hose manufacturer, and Nortek Global HVAC (UK) Limited and must only be carried out by a qualified/competent gas engineer.

fig.3. Correct installation of flexible gas connection



Depending on the specific installation, the flexible gas hose may be routed to the gas cock at any of the following angles in relation to the burner:

Vertical (fig.a)
 45° angle (fig.b)
 90° angle (fig.c)
 Any other position in between these angles is acceptable.

Table 3 Gas Supply Pressures

Gas Category	G20	G31
Gas type	Natural Gas	Propane
Maximum supply pressure mbar	50	57.5
Minimum supply pressure mbar	17.5	25
Gas supply	20	37

! Care must be taken to observe the minimum pipe bend diameter (minimum 250mm, maximum 350mm) & pipe expansion distance (minimum 30mm, maximum 70mm) as shown opposite

! Maximum bend diameter for the hose is 450mm.

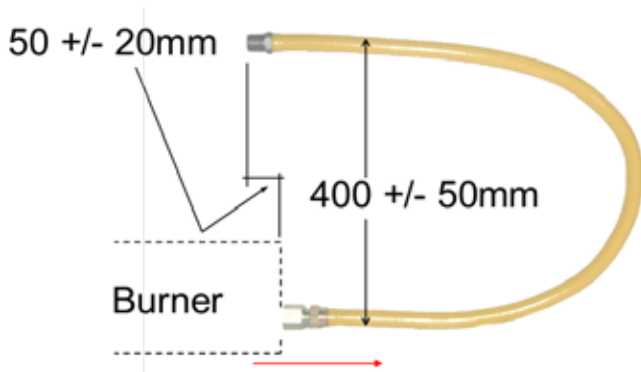

The correct installation as shown below will allow for approx 100mm of movement due to expansion

direction of expansion.



fig.d

The methods shown below are unacceptable, due to undue stress on the hose & fittings.

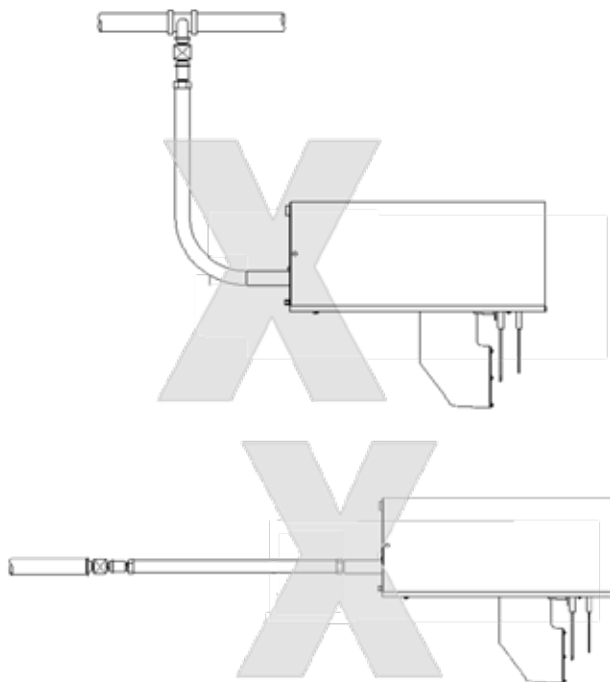

1.11 Electrical Connections

- * Standard burner 16W.
- * Current rating 0.05 amp per burner
- * Fuse: external 2 amp Slow Blow.

 Each component carrying an electrical supply must be earthed.

- * Supply to burners is 230V 50Hz single phase.
 - * Exhaust fans are three phase 415V 50Hz.*
 - * IP54 rated Inverter panel LRU's for B80/B160/B300 require a 230V single phase supply at 22A (B80/B160) or 30A (B300).
 - * IP54 rated Inverter panel LRU's for BH300 require a 4125V three phase supply at 30A.
 - * Standard LRU's require a 415V three phase supply at 25A (BH300 Non-inverter driven only).*
- * refer to individual site specifications.

All electrical work should be carried out to IEE standards by a competent electrician.

The electrical connection to the burner is made by means of a three pin plug-in-power connector. Live, neutral and earth connections should be made via a flexible supply cable to the power connector and routed clear of the heater or tubes.

The flexible supply cables to each burner should be of 0.5mm² minimum and comply with BS 6500. For fan and LRU supply, the wire size must be suitable for the current ratings as listed in Table 10.

The wires in the mains lead are coloured in accordance with the following code: Green & Yellow Earth; Blue Neutral; Brown Live.

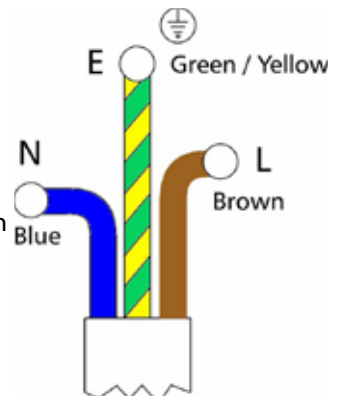

The method of connection to the electrical supply must facilitate complete isolation and should be via a fused double pole isolator having contact separation of at least 3mm on all poles and supplying the appliance only.

We recommend use of Nortek Global HVAC (UK) Limited approved controls. Please refer to SmartCom control manual for siting and installation details and figures 4.l and 4.m Where alternative controls are used, please refer to the manufactures instructions for their siting and installation details.

The controller shall have the means to allow the system to be turned off and on at least once in a 24hour period to facilitate a pressure switch check. The controller also requires the facility of a 0-10VDC output to modulate the system and MUST be programmed to provide 5 minutes high fire when there is a demand for heat before modulating the system.

Note: where Smartcom controllers are used only use those with software version 3.1 or higher.

Figure 4.a. Typical Burner Wiring Connections - single leg shown

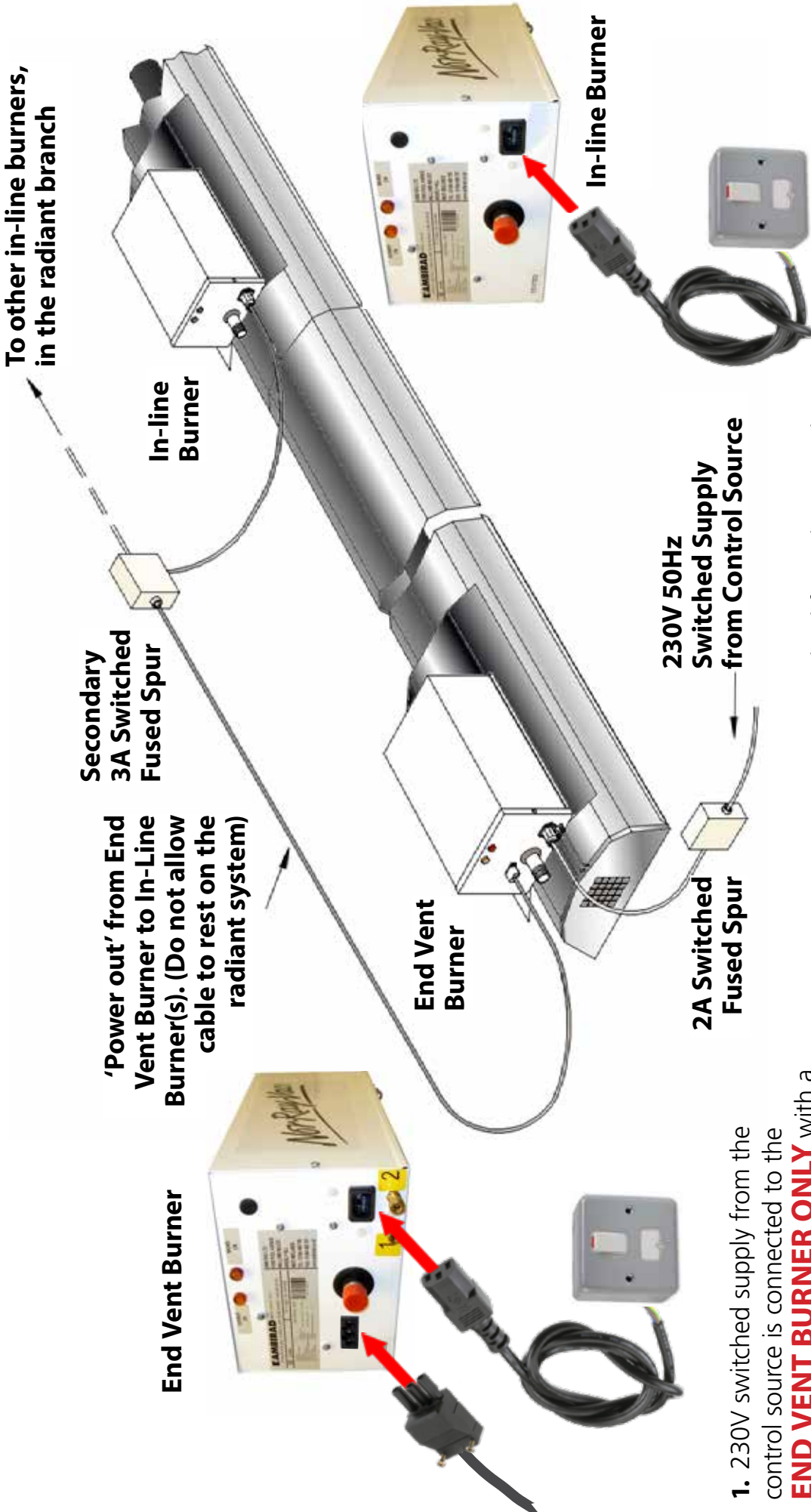

'Power out' from End Vent Burner to In-Line Burner(s). (Do not allow cable to rest on the radiant system)

Secondary 3A Switched Fused Spur

In-line Burner

To other in-line burners, in the radiant branch

End Vent Burner

2A Switched Fused Spur

230V 50Hz Switched Supply from Control Source

In-line Burner

1. 230V switched supply from the control source is connected to the **END VENT BURNER ONLY** with a mains lead via a 2A switched fused spur.
2. A 3 pin flat plug is wired in suitable 3 core cable and connected to the 'Power Out' socket of the **END VENT BURNER**. The cable is then terminated at a 2A switched fused spur adjacent to the **FIRST IN-LINE BURNER**.

3. Connect a mains lead from the secondary 2A switched fused spur to the **FIRST IN-LINE BURNER ONLY**. A suitable 3 core cable is then looped from this fused spur to a further 2A switched fused spur positioned adjacent to the **NEXT IN-LINE BURNER**. This burner is wired to the fused spur by a mains lead.
4. Repeat step 3 for any subsequent **IN-LINE BURNERS** within the same radiant branch only.

1.11.1.1 NRV 'M' system - Typical External Diagram

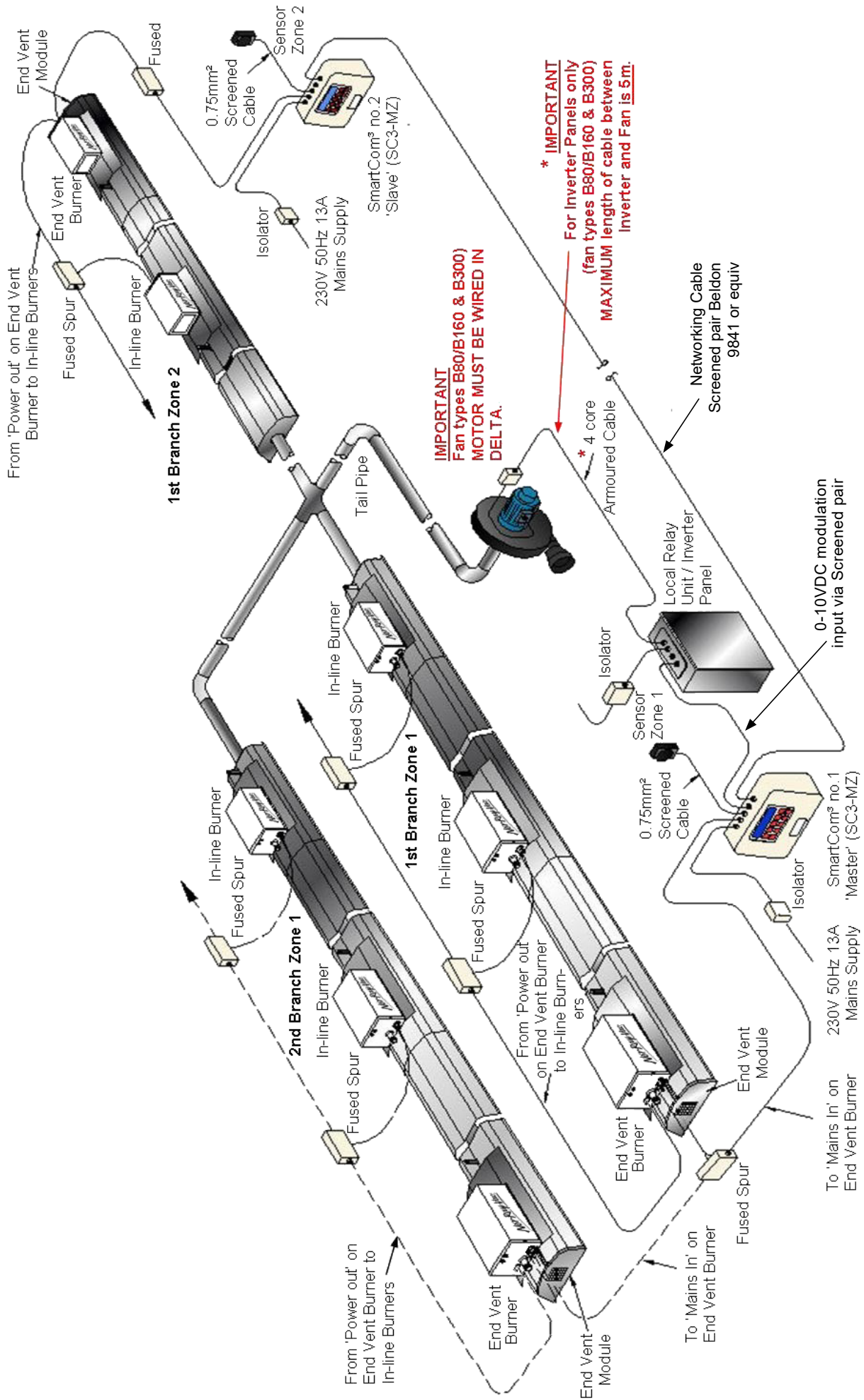

1.11.1.2 NRV 'M' system - Typical External Diagram - Independent Zonal Damper Modulating

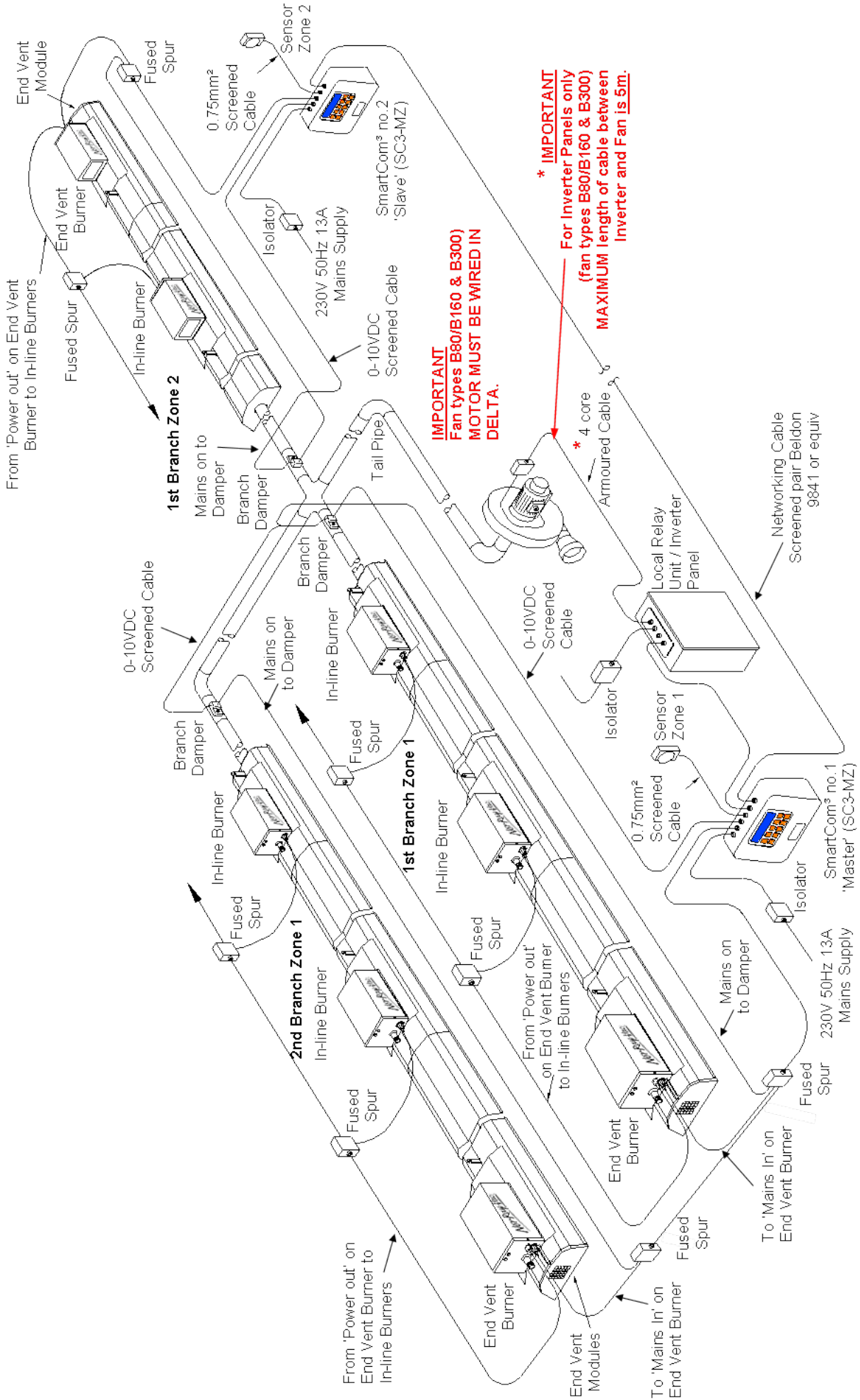

1.11.2 Wiring Details

Figure 4.c. NRV M internal wiring diagram - End Vent Burner (EV)

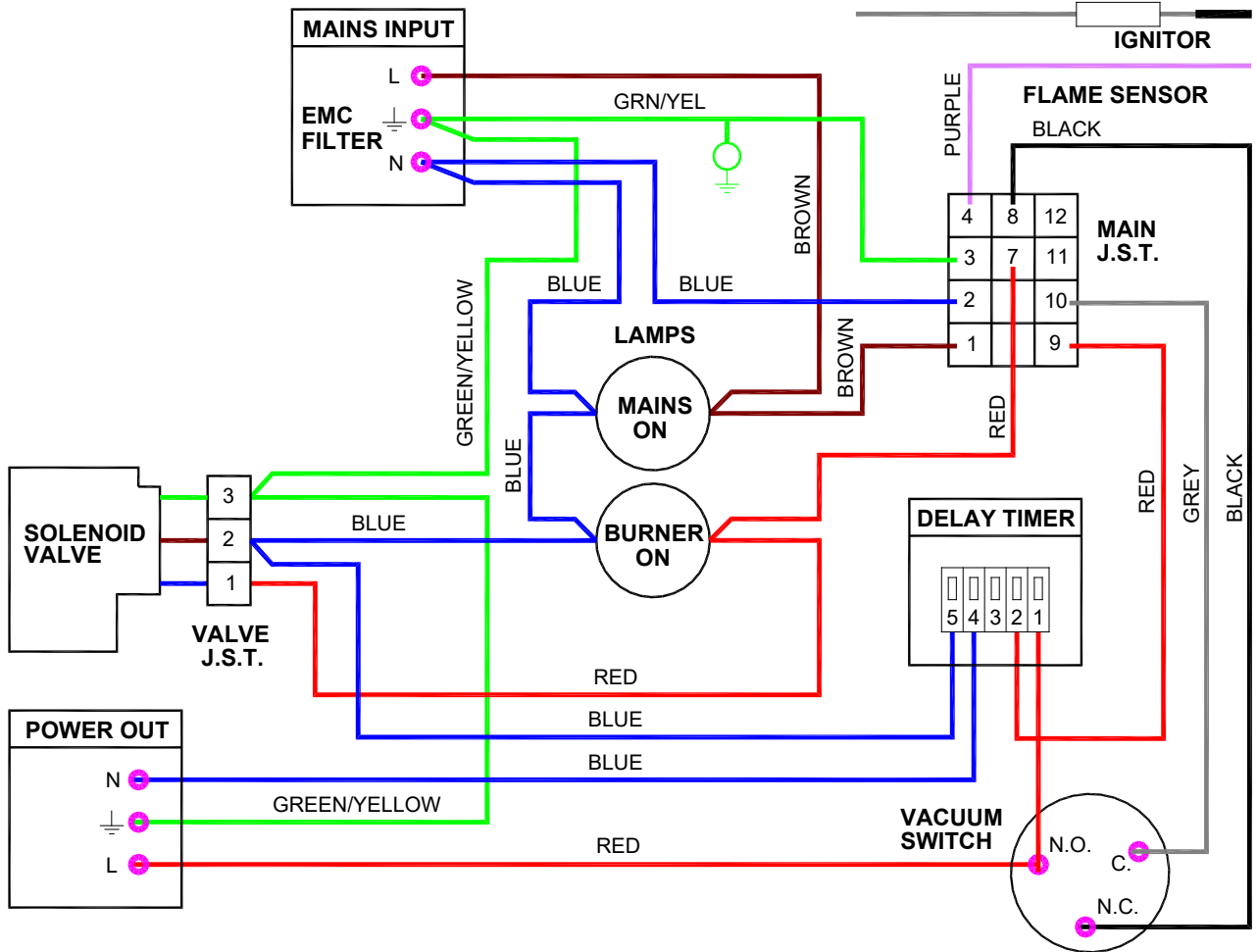

Figure 4.d. NRV M internal wiring diagram - In-line Burner (IL)

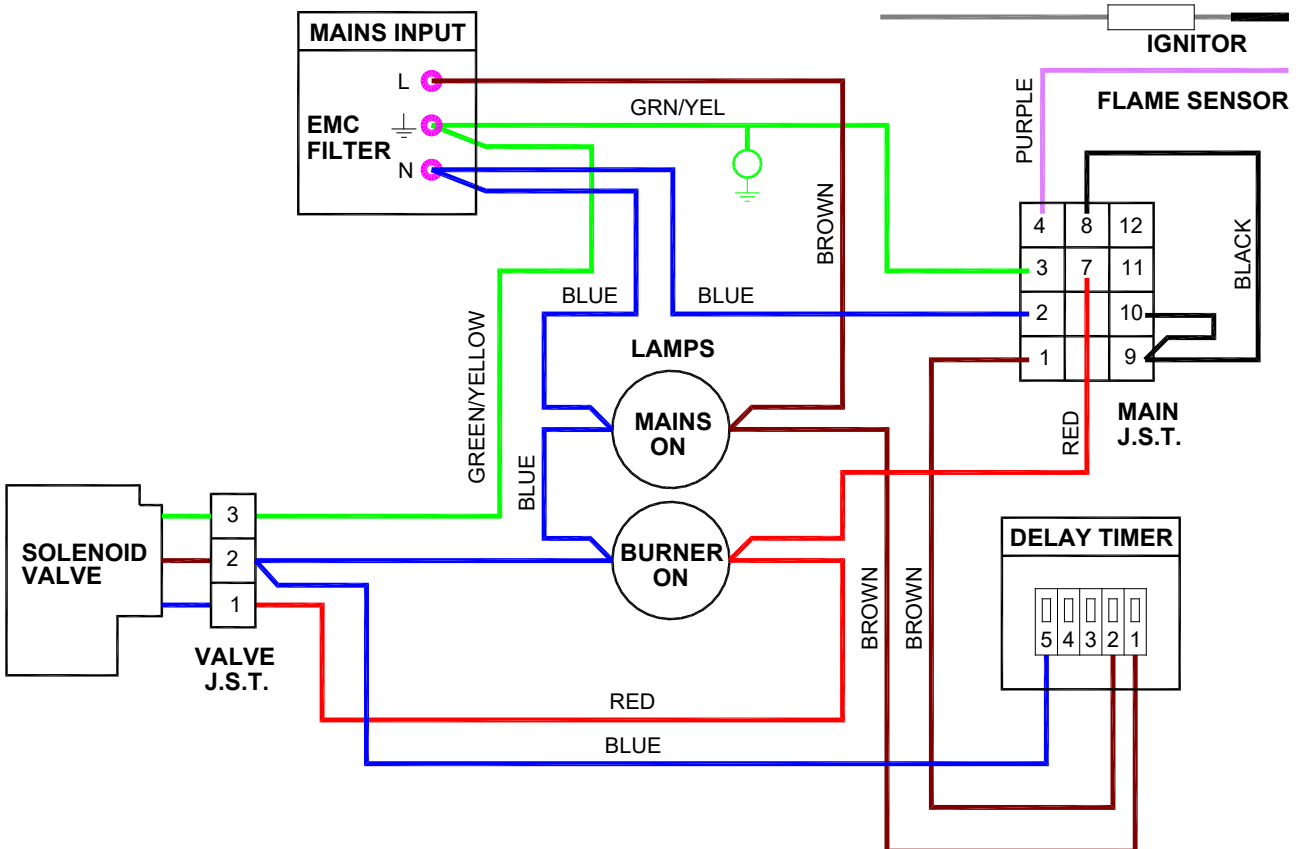

Figure 4.e. M internal wiring diagram - End Vent Burner c/w N/O or N/C volt free Lockout contacts

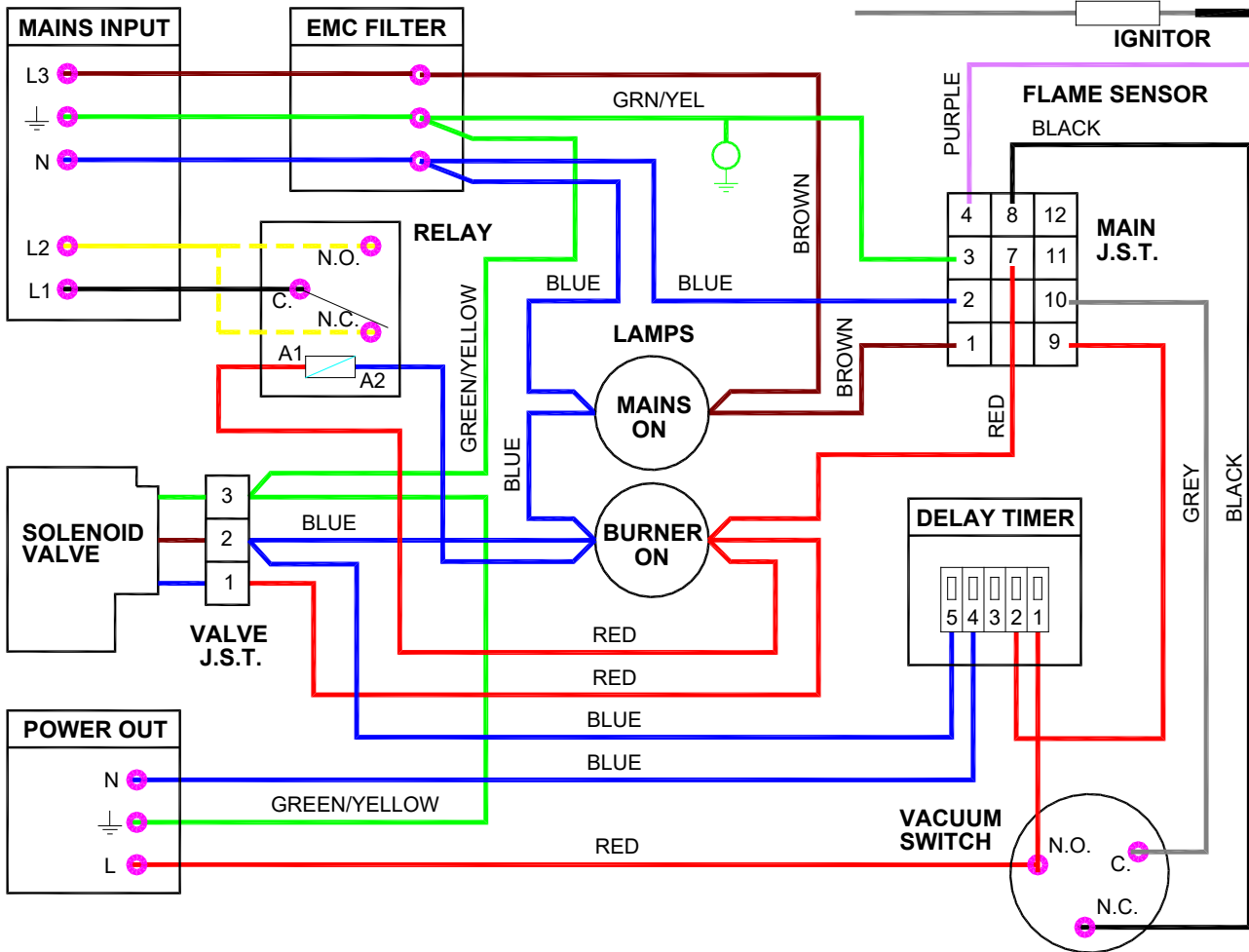

Figure 4.f. M internal wiring diagram - In-line Burner c/w N/O or N/C volt free Lockout contacts

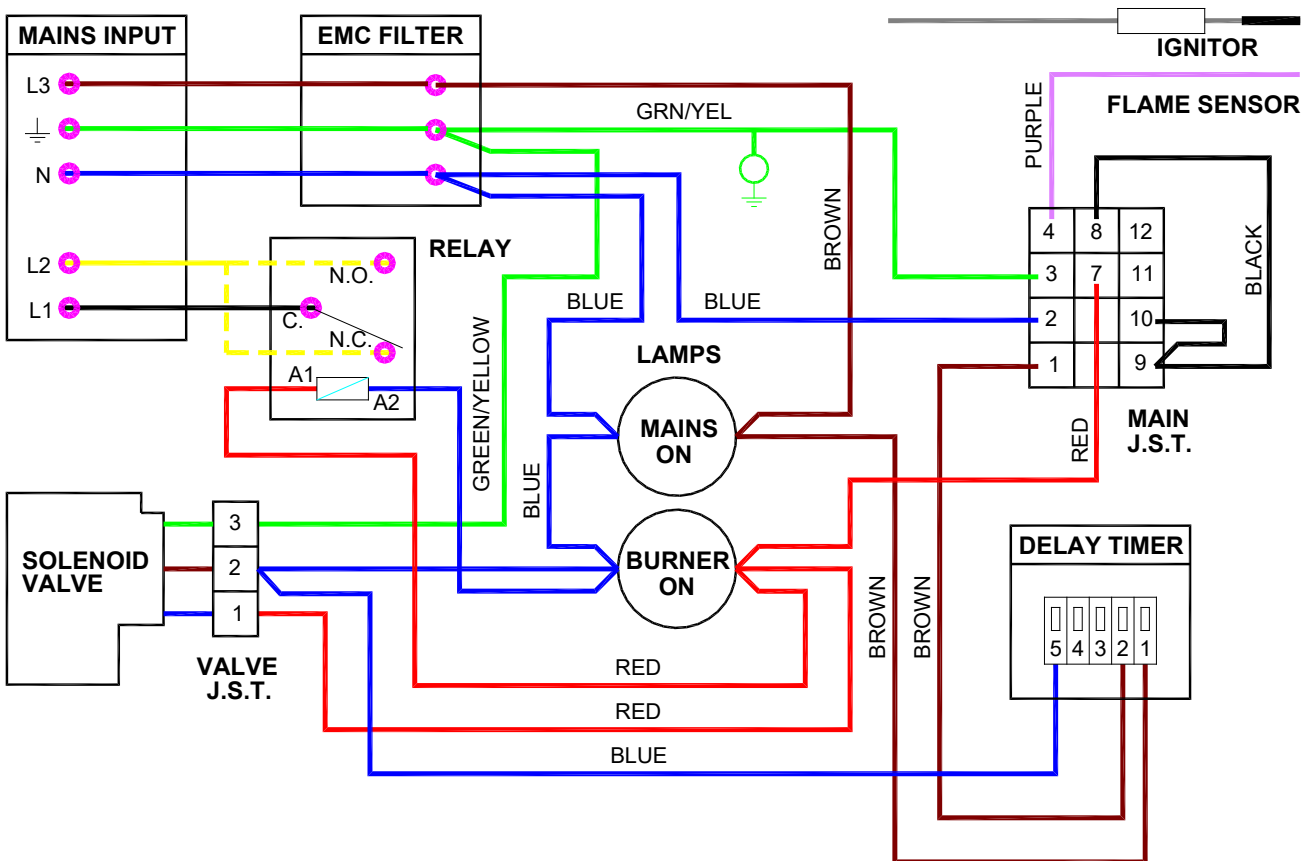

Figure 4.g. M internal wiring diagram - End Vent Burner c/w 3 way solenoid valve

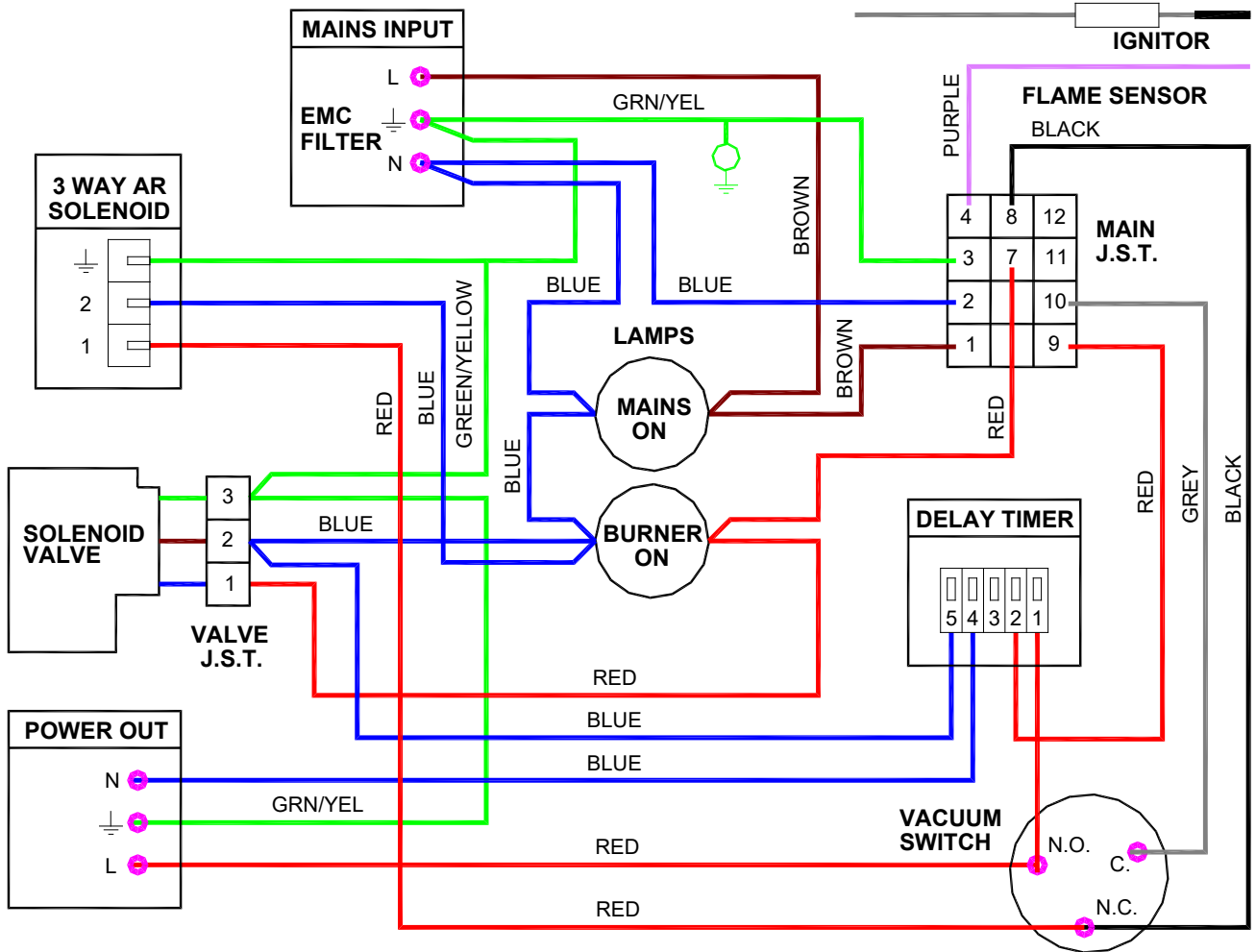

Figure 4.h. M internal wiring diagram - End Vent Burner c/w 3 way solenoid valve & N/O or N/C VF Lockout contacts

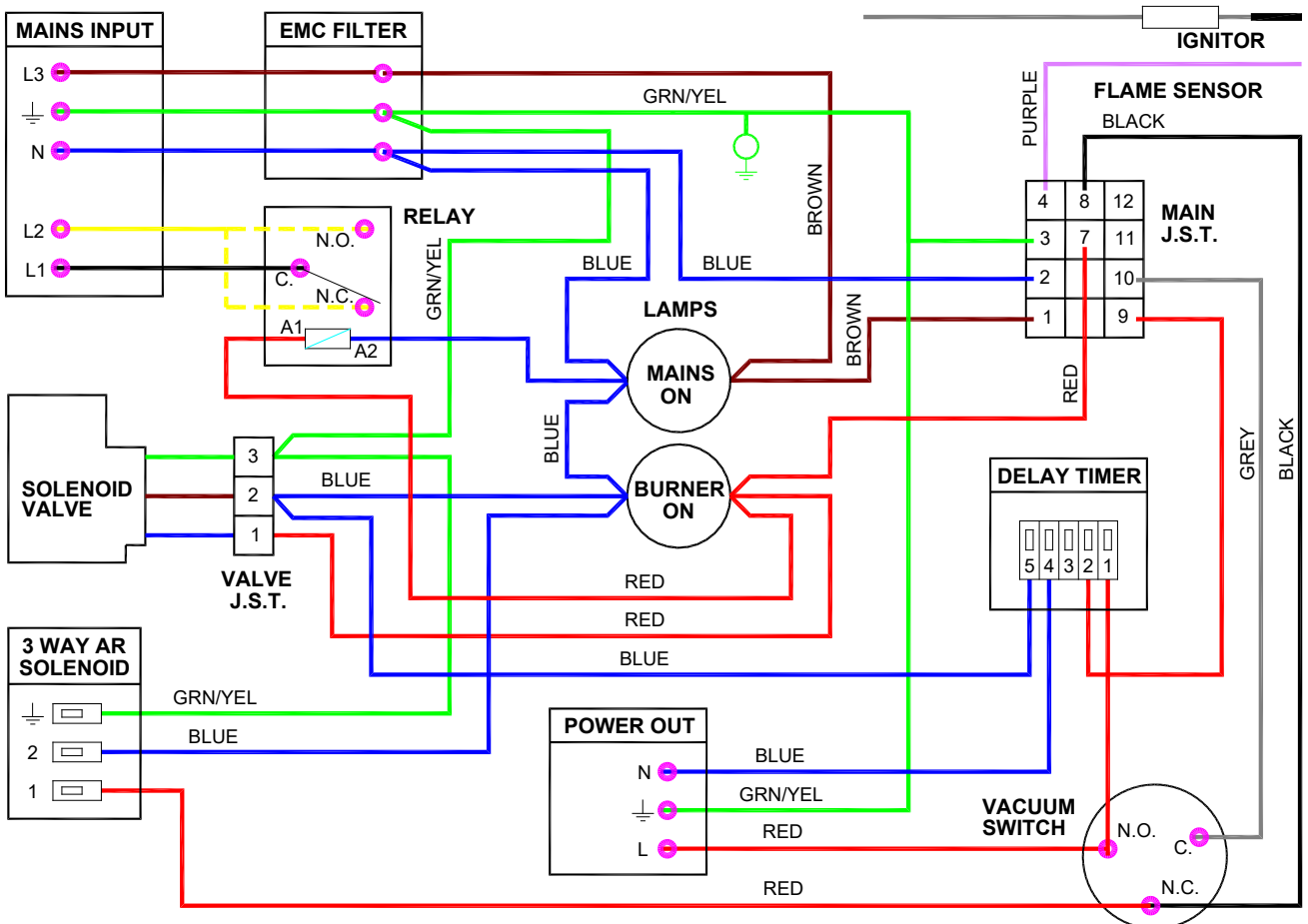

Figure 4.j. NRV Inverter Internal Wiring Diagram for B80, B160 and B300 three phase fans

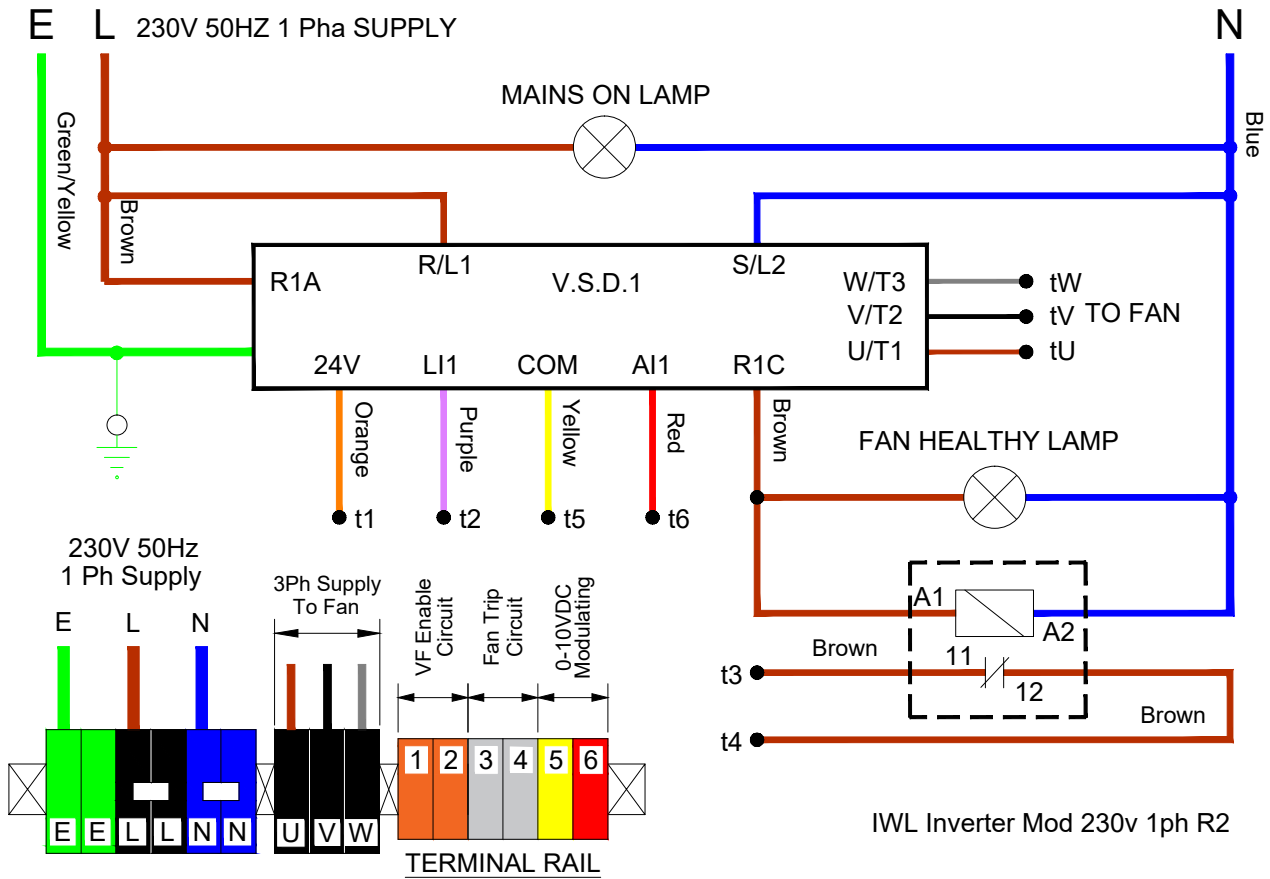

Figure 4.k. NRV Inverter Internal Wiring Diagram for BH300 three phase fans

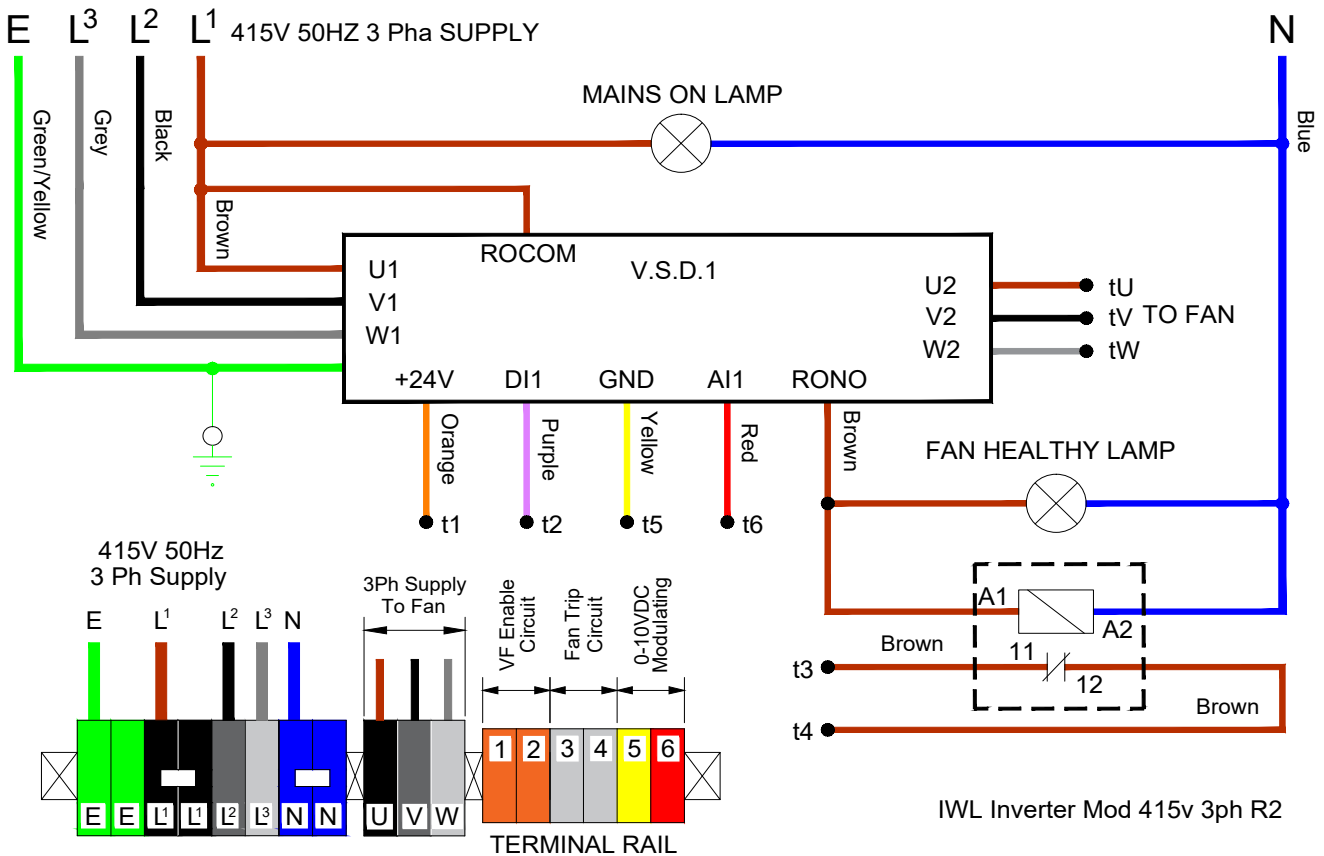
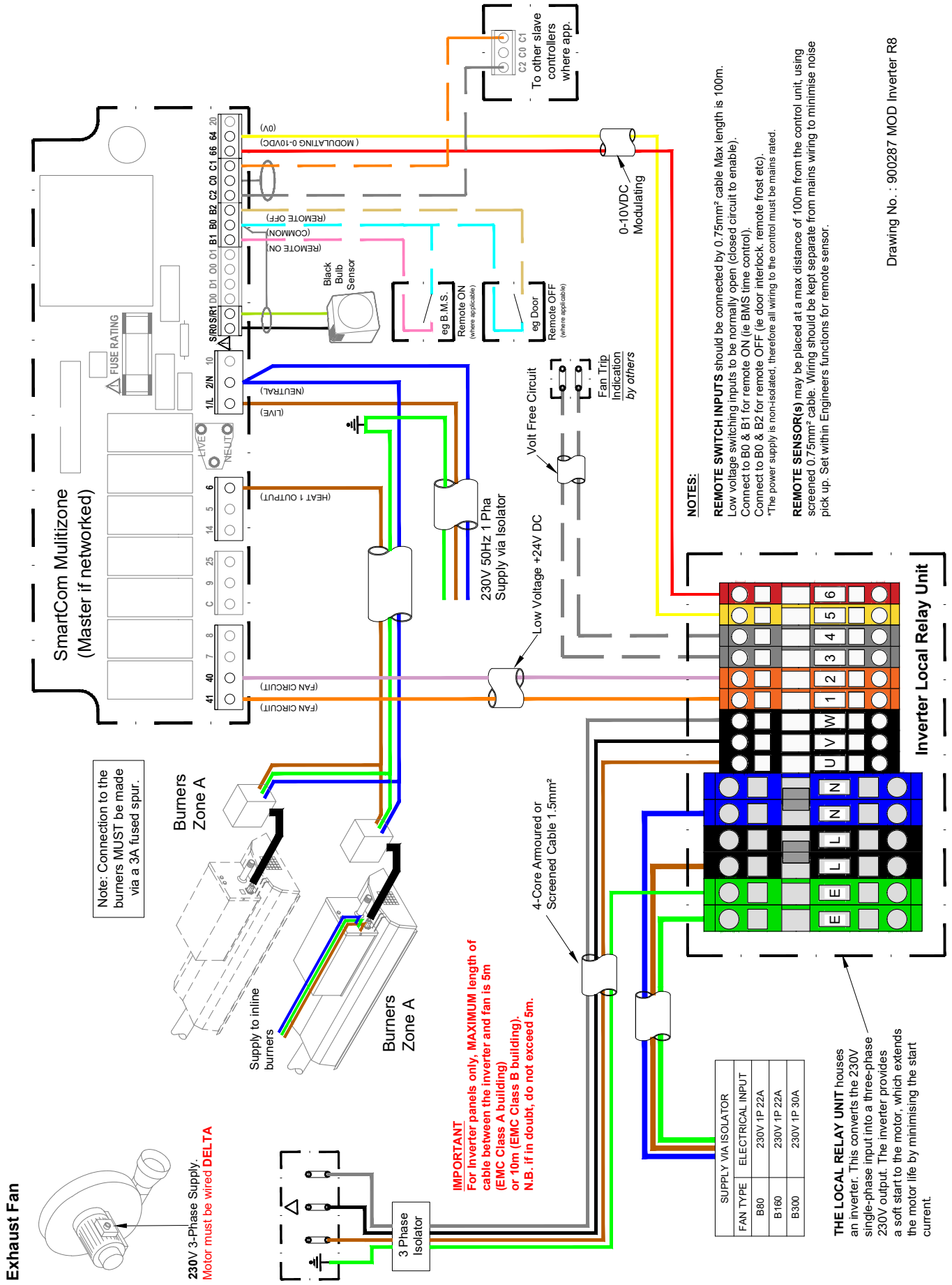

Figure 4.m. NRV M System Schematic interconnecting wiring. B80, B160 and B300 three phase fans. Modulating controlled by SmartCom3 via single phase inverter panel. (single zone shown)



Drawing No. : 900287 MOD Inverter R8

Figure 4.n. NRV M System Schematic interconnecting wiring. B80, B160 and B300 three phase fans. Modulating controlled by SmartCom3 and zonal branch dampers via single phase inverter panel. (1 zone shown)

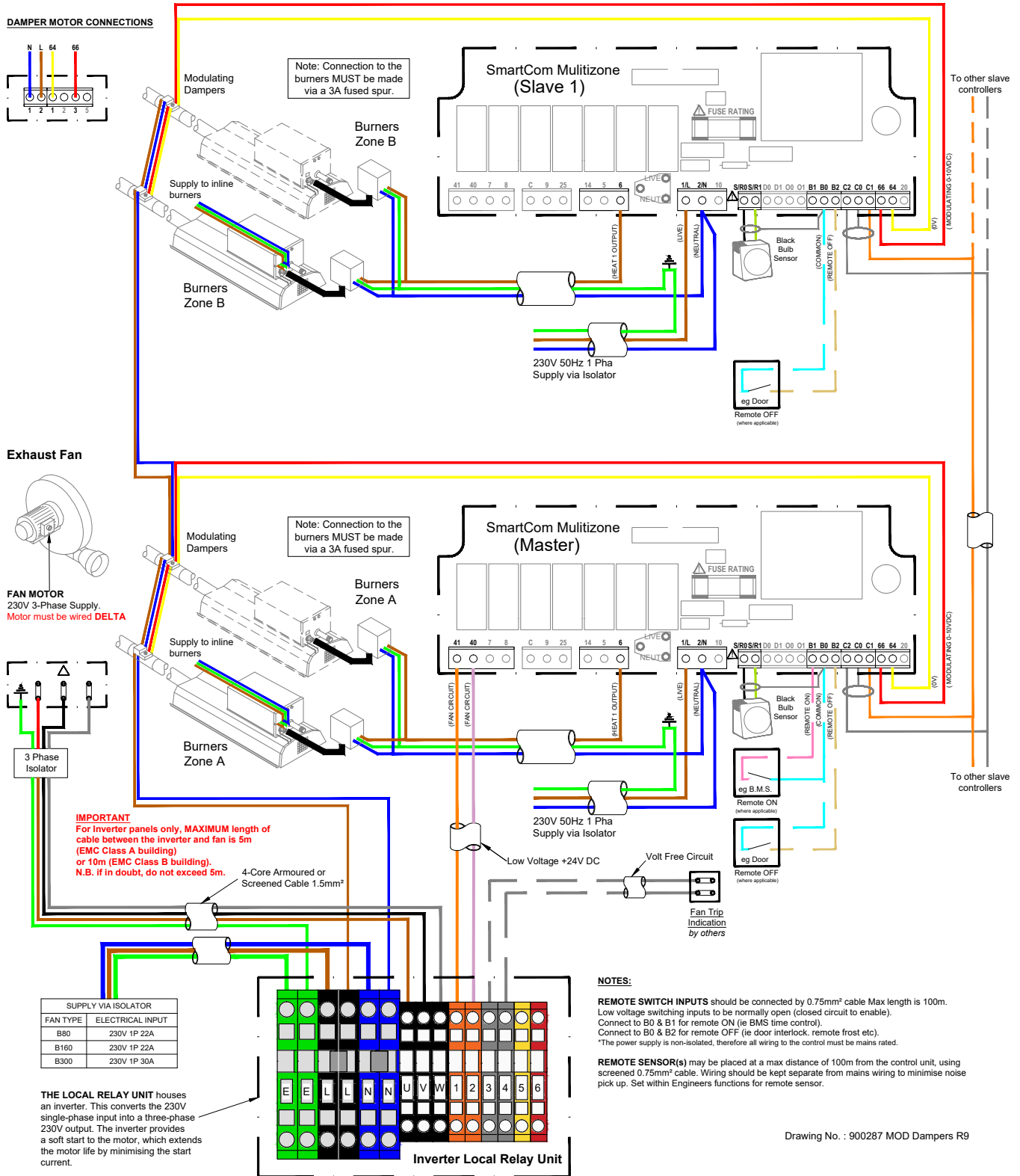
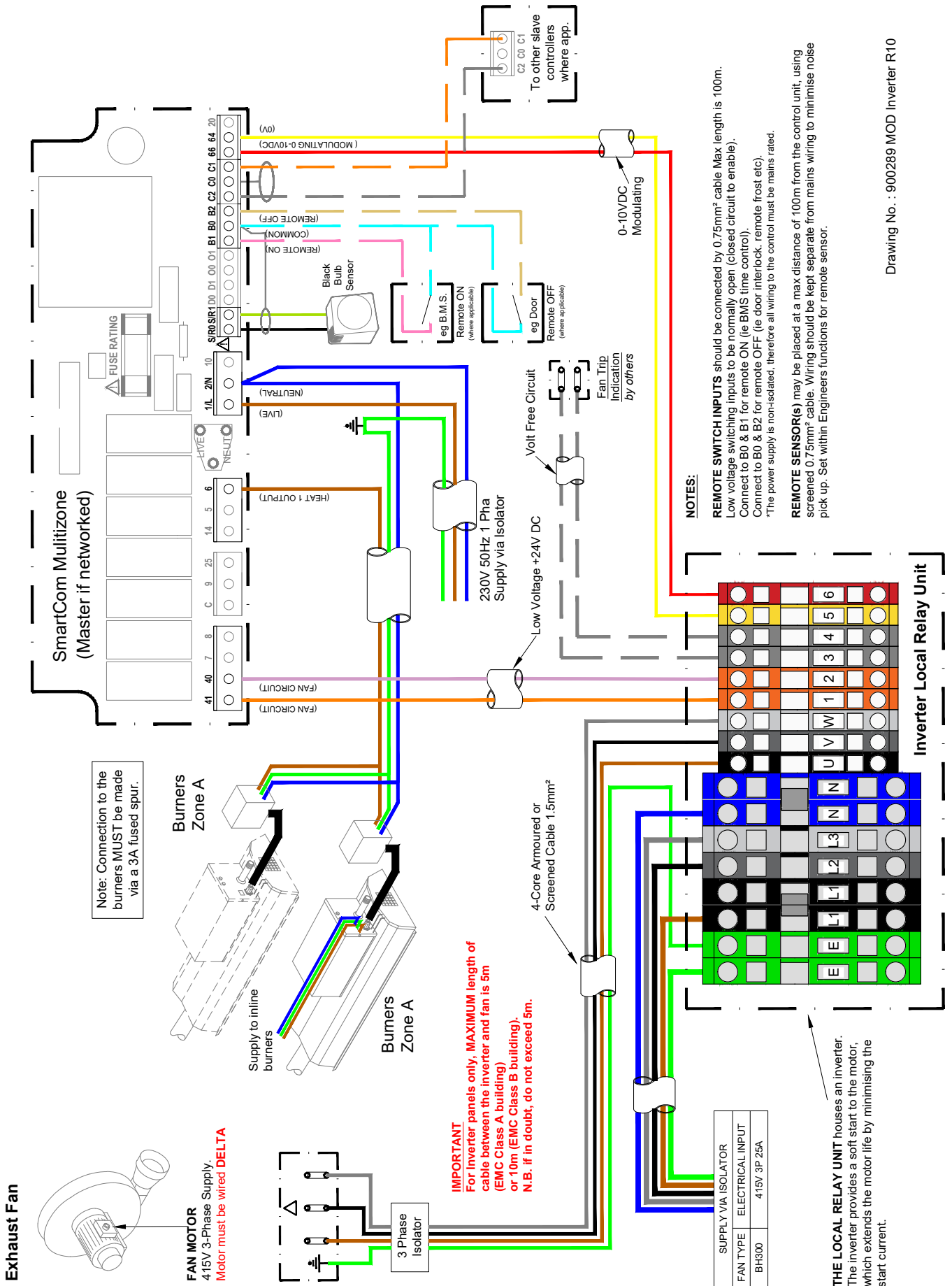
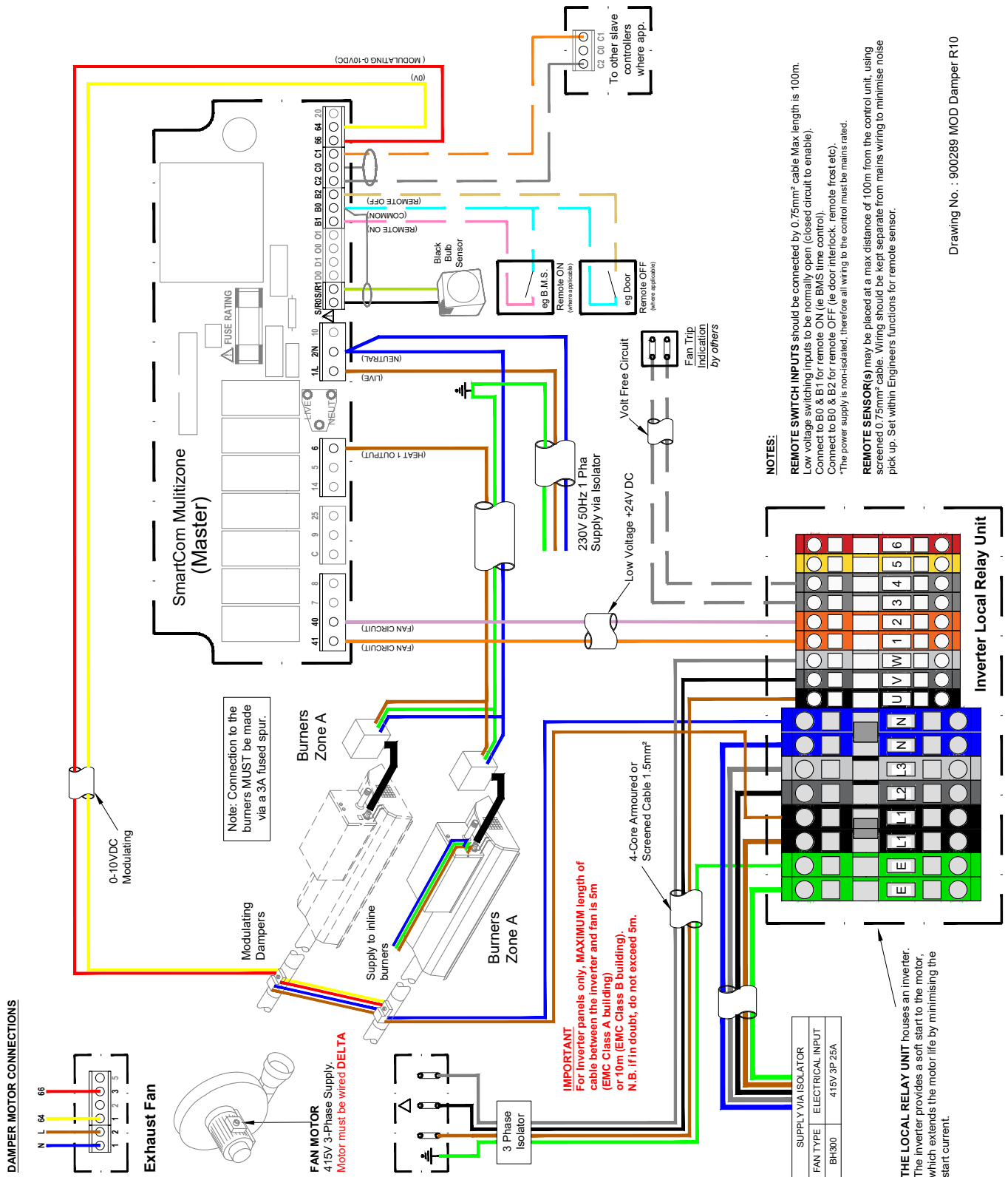

Figure 4.p. NRV M System Schematic interconnecting wiring. BH300 three phase fans. Modulating controlled by SmartCom3 via three phase inverter panel. (single zone shown)



Drawing No. : 900289 MOD Inverter R10

Figure 4.r. NRV M System Schematic interconnecting wiring. BH300 three phase fans. Modulating controlled by SmartCom3 and zonal branch dampers via three phase LRU panel. (1 zone shown)



Drawing No. : 900288 MOD Damper R10

Figure 4.s. NRV M System Schematic interconnecting wiring. BH300 three phase fans. Modulating controlled by SmartCom3 and fan damper via three phase LRU panel. (1 zone shown)

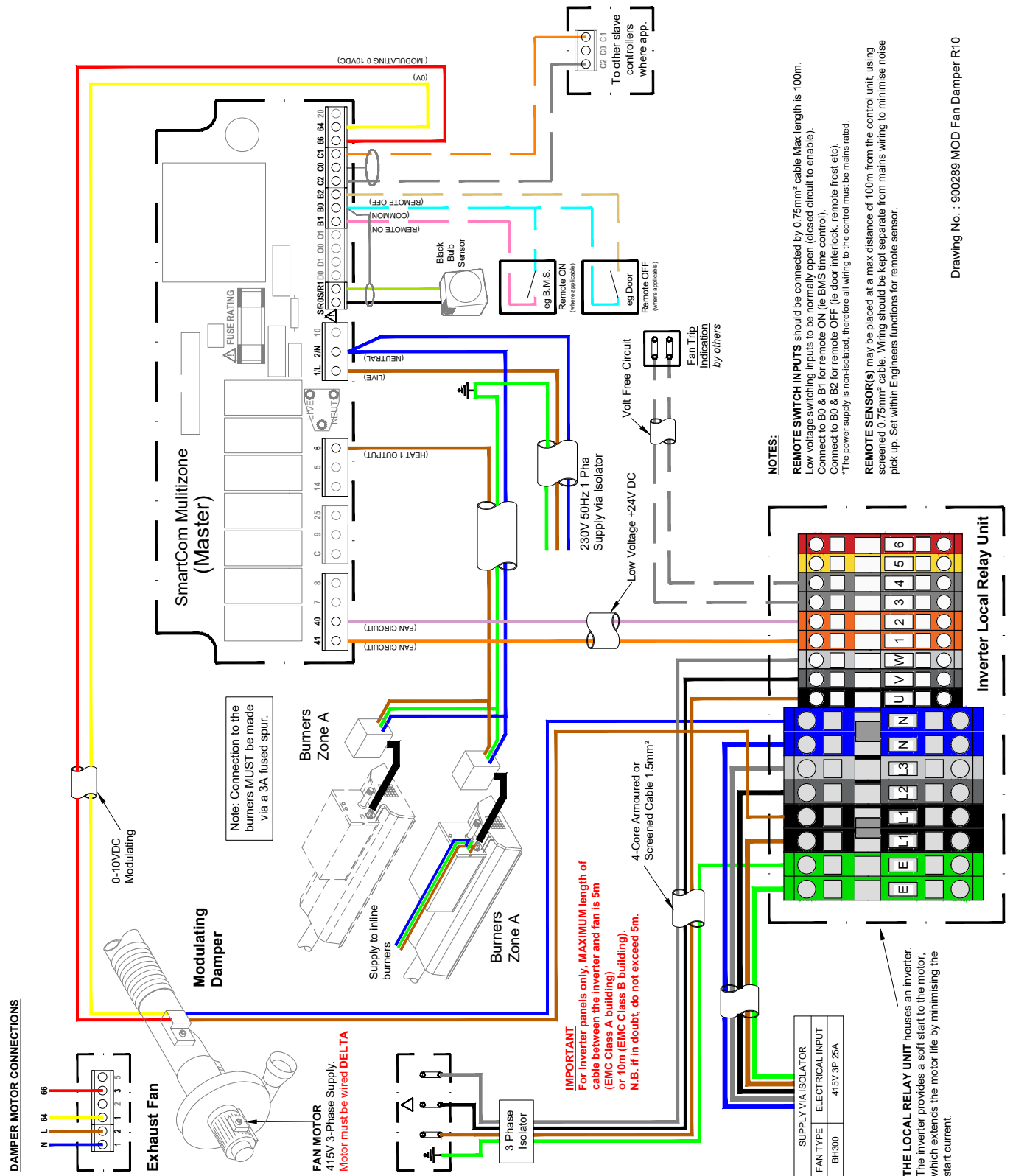

Drawing No. : 900289 MOD Fan Damper R10

Figure 4.t. Additional wiring for NRV M individual burner lockout

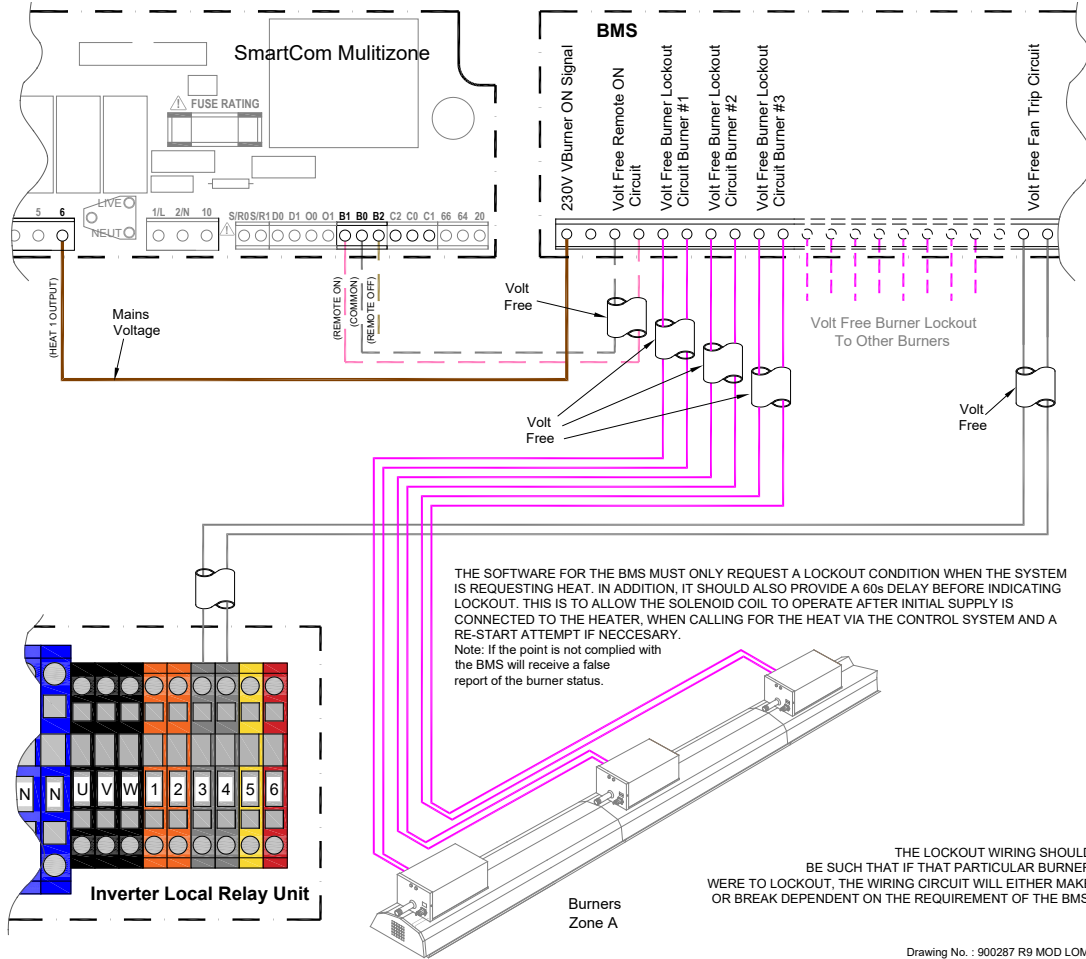
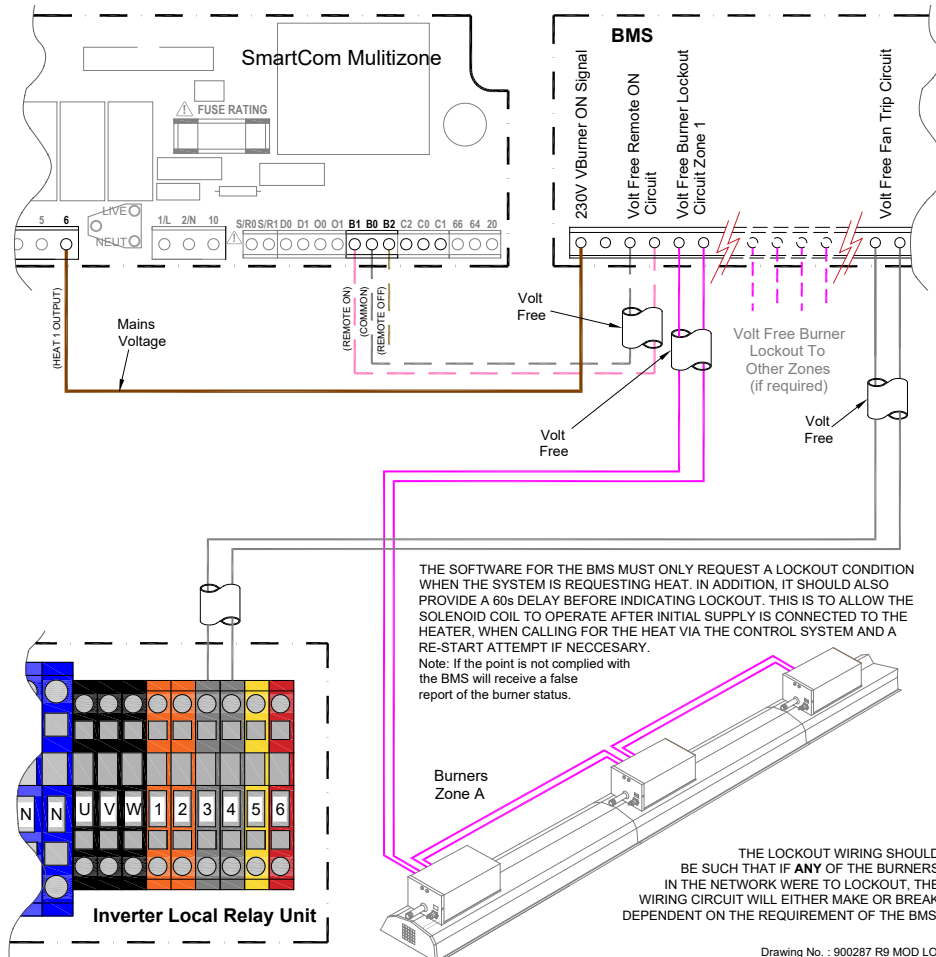

Figure 4.v. Additional wiring for NRV M zonal burner lockout



1.12 Ventilation Requirements

Nor-Ray-Vac heaters are installed as flued appliances in accordance with the relevant national requirements in the country of installation.

In buildings having an air change rate of less than 0.5 per hour, additional ventilation is required. For detailed information, please see BS6896 section 5.2.2.2.1

Natural Ventilation

Low level ventilation openings with a free area of at least $2\text{cm}^2/\text{kW}$ shall be provided. See BS6896 section 5.2.2.2.1.

1.13 Exhaust and Air Inlet - Options

fig5.a. Horizontal discharge

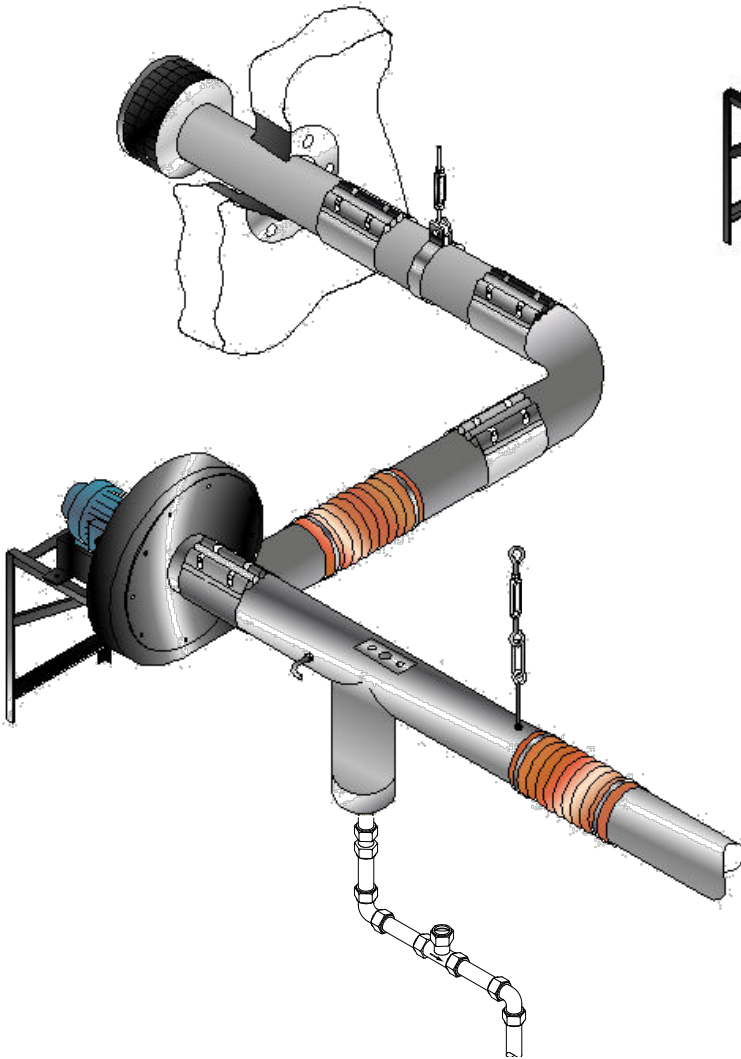
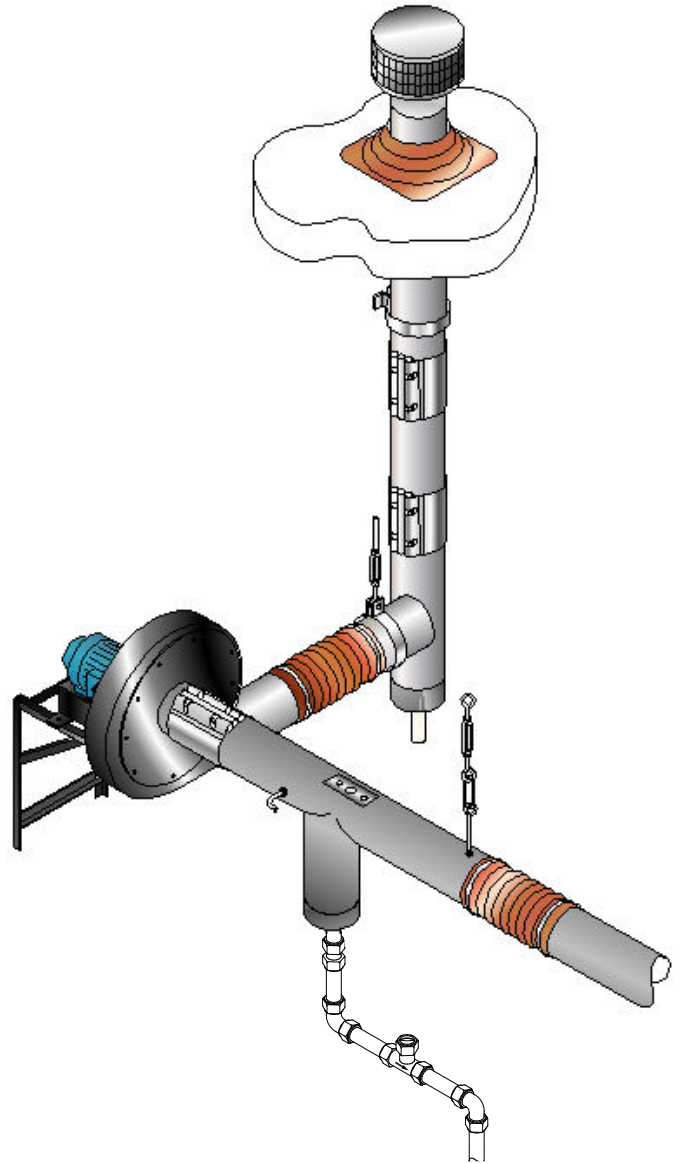

fig5.b. Vertical discharge



Considerations.

The vacuum fan must be located as shown in the layout drawing.

The vacuum fan must have a bottom horizontal discharge.

The fan should be fitted to the mounting platform which is fixed to the wall or building structure. Alternatively, the fan can be suspended from the roof structure, via drop rods (not supplied) and mounted on base frame. (Anti-vibration mountings are fitted between the fan and the mounting platform/base frame).

For full details of parts and installation, please refer to Booklet 2, Document Ref 700071

1.13.1 Ducted Air Inlet Considerations.

Heat resistant flexible tube is connected to the burner assembly ducted air adaptor and the EVM ducted air adaptor and connected to the air supply duct

The maximum length of 100mm diameter ductwork is 2m.

Ensure that the flexible supply duct does not drape over or touch the reflector.

ensure that the flexible ductwork is installed to allow for expansion of the heating system.

On a header duct, the main air supply header which is feeding the individual branch ducts and burner/end vent supply ducts must have a maximum pressure drop of 0.25 mbar (0.1in wg).

All joints and seams in the air supply system must be made air tight and a bird screen used at the inlet.

fig 5.c. Header Duct Connection

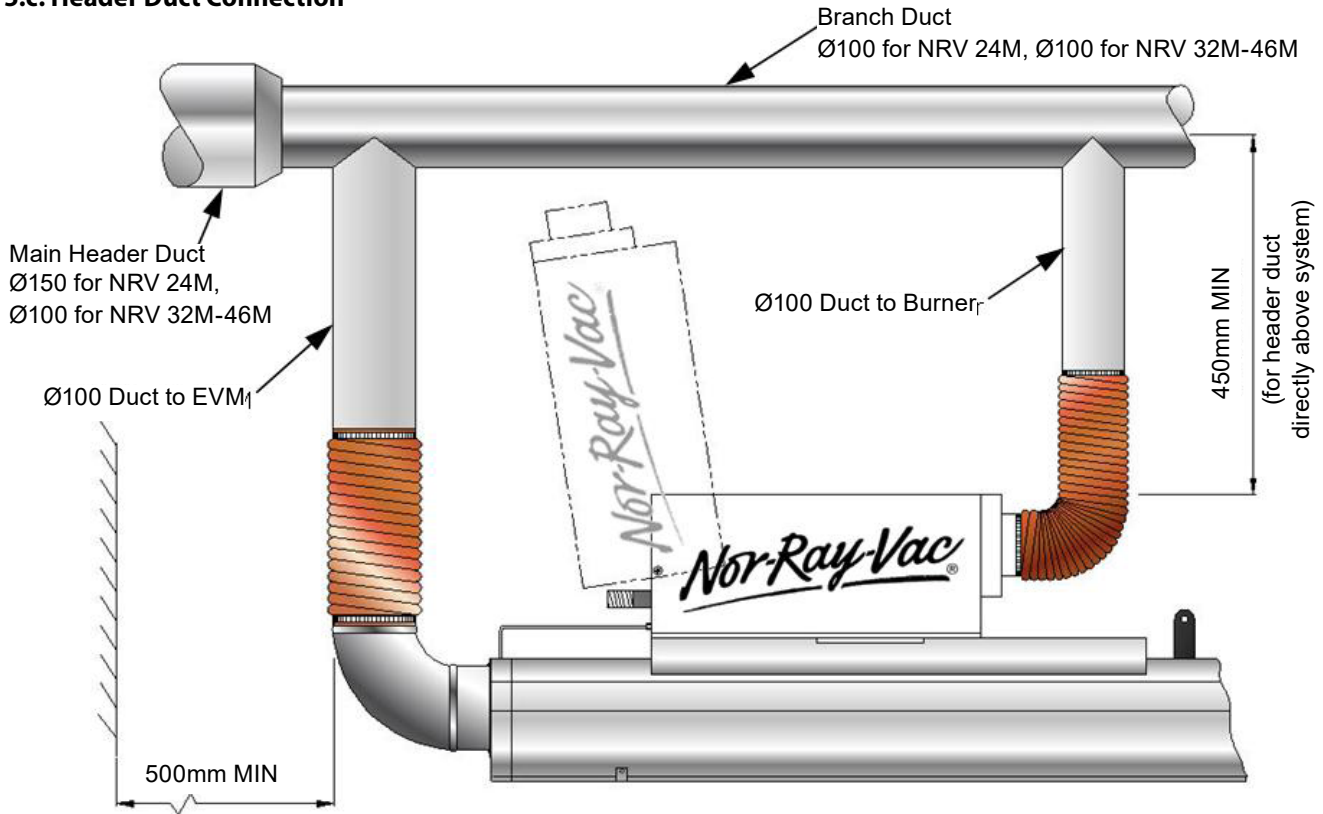
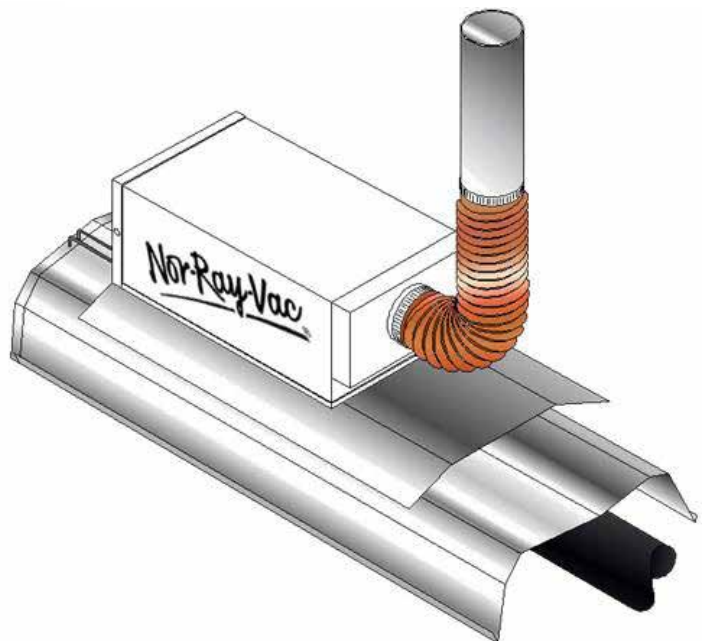
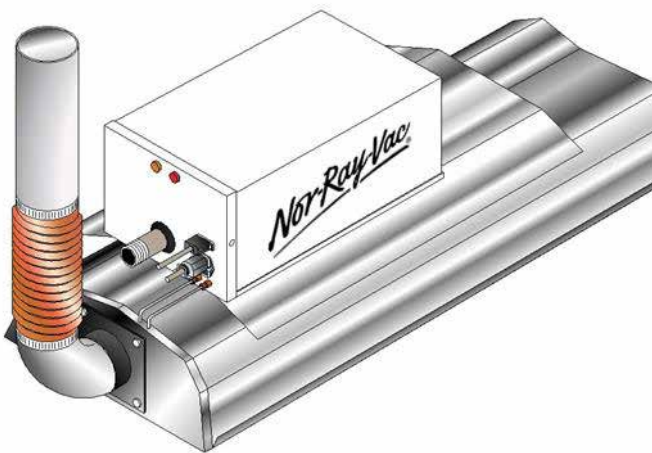
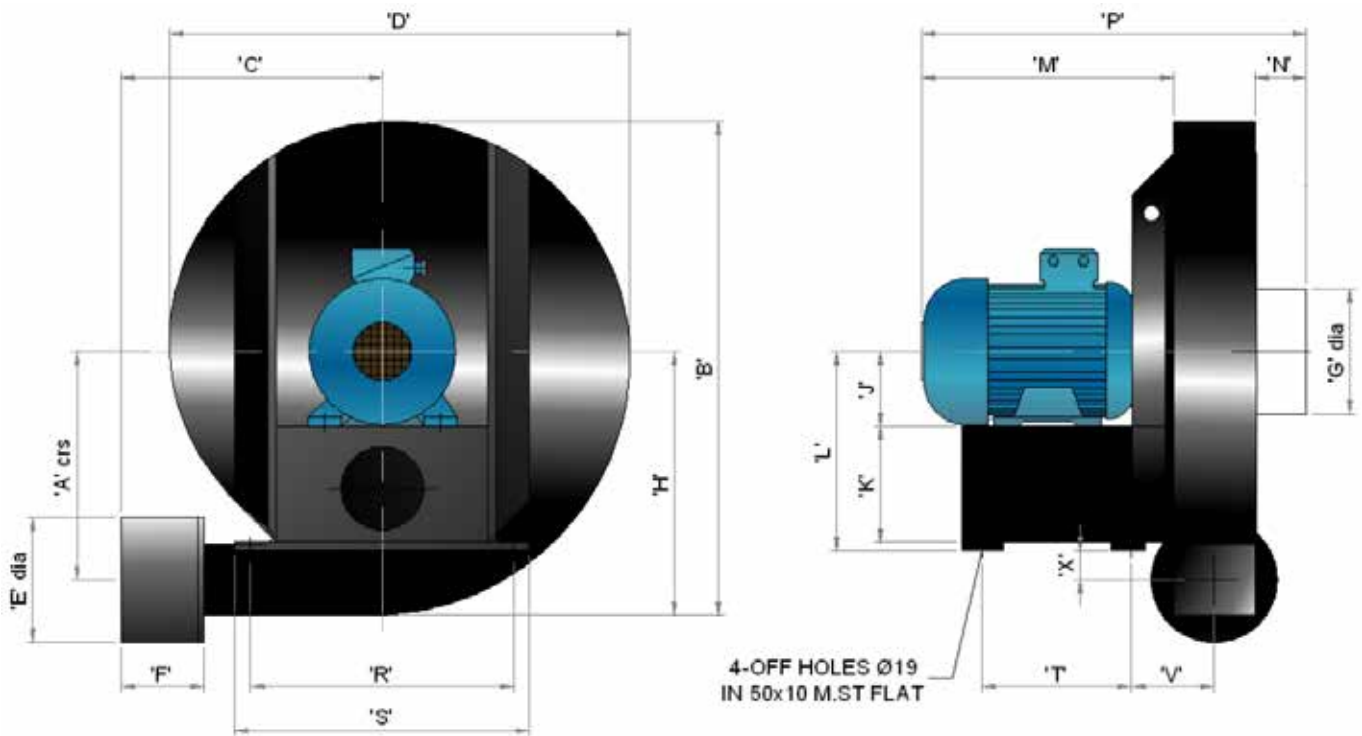

fig 5.d. End Vent Ducted Air Inlet Connection

fig 5.e. Burner Ducted Air Inlet Connection



1.14 Vacuum fan mounting details (Type 'B160' fan illustrated)



Fan Size	B80	B160	B300	BH300
A (crs)	216	276	286	324
B	595	595	625	704
C	305	308	330	352
D	580	555	575	650
E (Ø)	150	152	152	152
F	50	97	50	50
G (Ø)	150	150	150	148
H	295	318	340	380
J	80	90	90	110
K	150	140	140	120
L	240	240	240	240
M	309	303	341	404
N	50	62	157	157
P	421	463	616	680
R (crs)	318	318	318	318
S (crs)	356	356	3596	356
T	204	204	204	204
V	115	115	115	115
Z	21	36	46	84

1.15 Technical Details.

Tables 4a & b Burner Details

No of Injectors		1				
Gas Connection		½ in BSP Internal thread				
Burner current		0.05 (per burner)				
Electrical Voltage/Ph/Hz		230 volt 1 phase 50Hz				
Burner type		24M	32M	38M	46M	
Burner details						
G20 Natural Gas	Gas category		ii			
	Heat input (Gross) 100% rate Nat Gas G20	kW	24	32	38	46
	Heat input (Gross) 50% rate Nat Gas G20	kW	12	16	19	23
	Gas consumption 100% rate Nat Gas G20	m ³ /h	2.29	3.05	3.62	4.38
	Gas consumption 50% rate Nat Gas G20	m ³ /h	1.15	1.53	1.81	2.19
	Max Inlet pressure Nat Gas G20	mbar	50	50	50	50
	Min Inlet Pressure Nat Gas G20	mbar	17.5	17.5	17.5	17.5
	Hs Nat Gas G20	MJ/m ³	37.78	37.78	37.78	37.78
	Hi Nat Gas G20	MJ/m ³	34.02	34.02	34.02	34.02
	d Nat Gas G20		0.556	0.556	0.556	0.556
	Ws Nat Gas G20	MJ/m ³	50.72	50.72	50.72	50.72
	Wi Nat Gas G20	MJ/m ³	45.67	45.67	45.67	45.67
	Injector size Nat Gas G20	mm	4.9	5.4	5.8	6.3
	Injector Part No.		L100549	L100554	L100558	L100563
	Air shutter size Nat Gas G20	mm	19.5	22	24	26.5
Air shutter Part No.		L100320	L100314	L100316	L100318	
G31 Propane	Gas category		iii			
	Heat input (Gross) 100% rate Propane G31	kW	24	32	38	46
	Heat input (Gross) 50% rate Propane G31	kW	12	16	19	23
	Gas consumption 100% rate Propane G31	m ³ /h	0.90	1.21	1.43	1.73
	Gas consumption 50% rate Propane G31	m ³ /h	0.45	0.61	0.72	0.86
	Max Inlet pressure Propane G31	mbar	57.5	57.5	57.5	57.5
	Min Inlet Pressure Propane G31	mbar	25	25	25	25
	Hs Propane G31	MJ/m ³	95.65	95.65	95.65	95.65
	Hi Propane G31	MJ/m ³	88.00	88.00	88.00	88.00
	d Propane G31		1.55	1.55	1.55	1.55
	Ws Propane G31	MJ/m ³	76.84	76.84	76.84	76.84
	Wi Propane G31	MJ/m ³	70.69	70.69	70.69	70.69
	Injector size Propane G31	mm	4.0	4.4	4.8	5.2
	Injector Part No.		L100540	L100544	L100548	L100552
	Air shutter size Propane G31	mm	19.5	22	24	26.5
Air shutter Part No.		L100320	L100314	L100316	L100318	

Table 5. Heater Details

Burner type		24M	32M	38M	46M
Min distance between burners	m	9.4	14	18	23
Max distance between burners	m	13.1	18	23	27
Min distance between burner and fitting	m	5.0	6.0	7.0	8.0
Max tube temp	°C	450	480	480	480
Min mounting height	m	4.0	4.7	5.3	6.0
Max burners per branch		3	3	3	3

Table 6. Heater Noise

Burner type		24M	32M	38M	46M
Noise level @ 3m below In-Line BURNER	db(A)	37	tba	tba	tba
	NR±2	33	tba	tba	tba
Noise level @ 3m below EVM Burner	db(A)	tba	tba	tba	tba
	NR±2	tba	tba	tba	tba
Noise level @ 3m below EVM with silencer	db(A)	tba	36	tba	tba
	NR±2	tba	33	tba	tba
Noise level @ 3m below EVM Burner with Ducted Air	db(A)	tba	37	tba	tba
	NR±2	tba	34	tba	tba

Table 7. System Weights

* without burners or ducted air systems

Burner type		24M	32M	38M	46M
LR Burner	kg	8.3	8.3	8.3	8.3
Radiant branch*	kg/m	8.3	8.3	8.3	8.3
Radiant branch + Slimline grille*	kg/m	10.9	10.9	10.9	10.9
Radiant branch + Protective guard*	kg/m	10.0	10.0	10.0	10.0
4" Mild steel tail pipe	kg/m	5.5	5.5	5.5	5.5
4" Aluminum tail pipe	kg/m	0.9	0.9	0.9	0.9
6" Mild steel tail pipe	kg/m	10.6	10.6	10.6	10.6
6" Aluminium tail pipe	kg/m	1.3	1.3	1.3	1.3
Max / susp point @ EV position	kg	24.2	24.2	24.2	24.2

Table 8. Fan Details

Fan type		B80	B160	B300	BH300
Fan part number		201760	201761	201762	201763
Motor (TEE)		Q2E80M2D-KG-H	Q2E90L2C-KG-H	Q2E90L2D-KG-H	Q2E112M2C-KG-H
Power	kW	1.1	1.5	2.2	4.0
Supply to Fan	V/Hz/P	230-50/3	230-50/3	230-50/3	415-50/3
Run Current	A	4.24	5.6	8.14	7.7
Start Current	A	n/a	n/a	n/a	54
Speed	RPM	2850	2860	2840	2880
Wired	Inverter	Δ	Δ	Δ	Δ
	D.O.L.	∩	∩	∩	Δ
Flow rate @ 20°C	m ³ /h	368	736	1380	1380
Flow rate @ 150°C	m ³ /h	259	519	972	972
Pressure	mbar	29	29	29	42
Max Operating Temp.	°C	200	200	200	200
Weight	kg	45	52	58	75

Table 9. LRU Details

Fan type		B80	B160	B300	BH300	
LRU part number		900274	900088	900089	900632	900282
Inverter type	kW	1.5	1.5	2.2	4.0	STD LRU
Supply to LRU	V/Hz/P	230-50/1	230-50/1	230-50/1	415-50/3	415-50/3
Line Current	A	14.8	14.8	20.8	15	n/a
Motor Current	A	4.24	5.6	8.14	7.7	7.7
Fuse Rating	A	22	22	30	25	n/a
Acceleration Time	s	25	25	25	25	n/a
Deceleration Time	s	25	25	25	25	n/a

Table 10. Fan Noise Data

Fan type		B80	B160	B300	BH300
Noise level @ 3m below fan	db(A)	63	64	65	68
	NR±2	57	58	59	62
Noise level @ 3m below fan with motor muff	db(A)	62	63	64	66
	NR±2	56	57	58	60
Noise level @ 3m below in acoustic enclosure	db(A)	51	53	55	58
	NR±2	45	47	49	52
Flue horizontal/vertical @ 3m	db(A)	69	72	75	77
	NR±2	63	66	69	71
Flue horizontal/vertical @ 3m With exhaust silencer	db(A)	56	57	58	58
	NR±2	50	61	52	52

3. Commissioning Instructions.

 These appliances should be commissioned by a qualified engineer.

3.1 Tools Required.

The following tools and equipment are advisable to complete the tasks laid out in this manual.

 Suitable alternative tools may be used.

3.2 General



Leather Faced
Gloves



Various Pozidrive
Screwdrivers



Various Flat Head
Screwdrivers



Allen Key set



Adjustable Spanner
or 22, 26 & 27mm
Spanners



Manometer

 Under normal working conditions it is recommended that the Nor-Ray-Vac 'M' series system is regularly maintained to ensure long life and efficient operation.

Maintenance is required only once per year.

In dusty or dirty conditions more frequent maintenance is desirable. Servicing work must be carried out by a qualified gas service engineer.

Important

When maintaining or servicing the Nor-Ray-Vac 'M' series systems:

- * Never rest anything, especially ladders against heating system.
- * Isolate gas and electrical supplies before commencing any service work.

3.3 Commissioning Procedure

3.3.1 Start Up Checks

3.3.1.1 Check that the installation is to the design layout drawing and installed in accordance with the installation instructions.

3.3.1.2 Check installation electrically. Ensure that the vacuum fan, inverter, burners and control panel are wired correctly to diagrams provided.

3.3.1.3 Ensure that each burner is electrically disconnected at the plug/socket.

3.3.1.4 Set individual burner delay timer dip-switches (located in each burner) to required setting.

Refer to section 3.3.1.8

3.3.1.5 With the gas turned on, check the burner inlet pressure.

 The gas pressure at the burner inlet connection must not exceed:

50 mbar (20in wg) for Natural Gas G20 and 57.5 mbar (23in wg) for G31 Propane Gas.

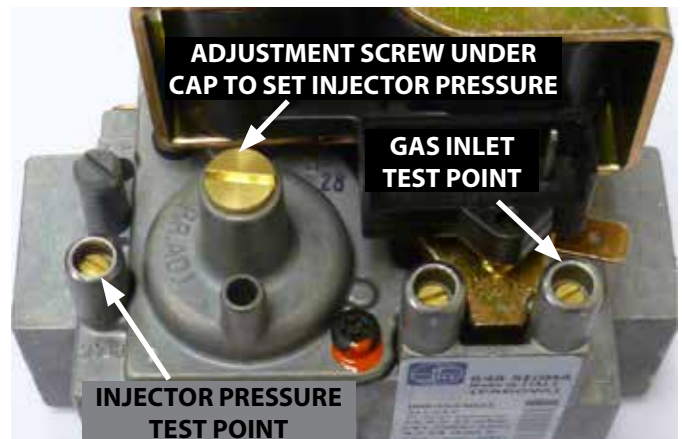

3.3.1.6 Start the vacuum fan.

 Note For various controllers/BMS systems it may be necessary to adjust the set point to above room temperature.

 For fans with an inverter panel, check that the display states "rdy" (ready).

3.3.1.7 Check for correct fan rotation.

3.3.1.8 Adjust the vacuum setting.

3.3.1.9 Burner Timer Dip-switch Adjustment

Each burner is fitted with an adjustable burner delay timer. The timer is adjusted using dip-switches located on top of the timer casing.

The dip-switches are labeled 1, 2, 3 and 4. These numbers correspond to the burner positions within the radiant branch.

The burner located nearest to the exhaust fan in that branch is noted as Burner 1, this is the case irrespective of how many other burners are in that branch.

The burner directly behind burner 1 is always noted as Burner 2, the burner directly behind Burner 2 is Burner 3 and so on finishing at the End Vent Burner.

Set the burner timer dip-switch.

For example, the timer on burner 1 is set by sliding the white dip-switch, positioned above the number 1, towards the number. The timer on burner 2 is set by sliding the white dip-switch, positioned above the number 2, towards the number.

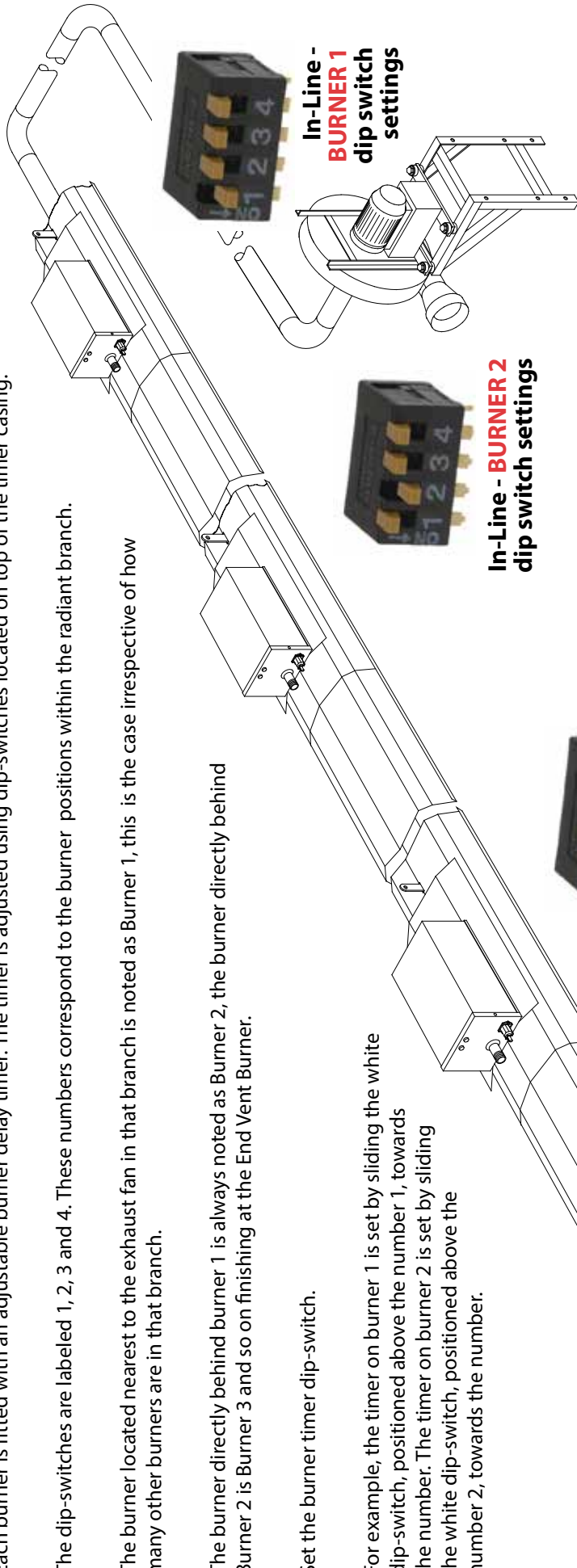

Table 11. Quantity of burners in-line

Individual Dip-switch position	Quantity of burners in-line				
	*1	*2	*3	*4	*5
1	1				
2	1	2			
3	1	2	3		
4	1	2	3	4	
5	1	1	2	3	4

To set dip-switch slide the white switch toward the numbers (1 - 4)

*Burner number within each radiant branch - lowest number closest to fan

The end vent vacuum is measured by removing the protection cap on the tee piece in the air impulse line on the end vent burner and connecting a manometer.



3.4 Inverter Driven Modulating Fans (B80, B160, B300 with Schneider inverter)

The use of an inverter allows the end vent suction to be adjusted by varying the output speed of the inverter within the local relay unit. This is achieved via a 0-10Vdc input direct to the inverter via an external control.

NOTE: Ensure the modulation input setting in the inverter functions has been adjusted accordingly.

3.4.1 Press the mode button 3 times until 'ConF' appears on the display.

3.4.2 Press the jog dial to enter. Rotate jog dial until 'A l It' is displayed. Press jog dial to enter.

3.4.3 Rotate jog dial until 'lOU' is displayed. Press jog dial to enter, causing the inverter to accept 0-10Vdc.

3.4.4 Ensure that electrical supply to the end vent modules and burners in each branch are connected.

3.4.5 Check that the fan and branch dampers are fully open and secure.

3.4.6 Ensure the controller is in a programmed ON function and above the actual room temperature.

3.4.7 After a 30s delay the fan should run and the inverter should be showing the motor frequency in the display.

3.4.8 Press the mode button 3 times until 'ConF' appears on the display.

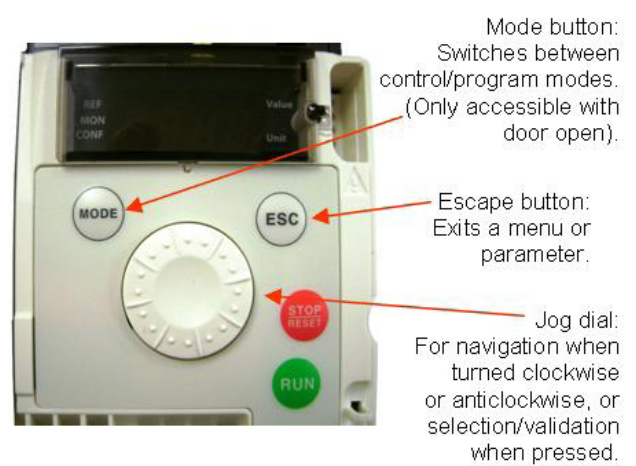

3.4.9 Press the jog dial to enter. Rotate jog dial until 'HSP' is displayed. Press jog dial to enter.

3.4.10 Rotate jog dial to adjust frequency. Press jog dial to enter new value, causing the inverter to change its speed.

3.4.11 Adjust the frequency until each burner has lit.

Frequency is usually between 35 and 50 (Hz)

3.4.12 Press the ESC button twice to return the inverter to the 'rdY' display.

3.4.13 Remove heat demand from the system and allow fan to halt.

3.4.14 Return heat demand to system. After a 30s delay the fan should run and a red neon should have illuminated on the rear of each burner.

3.4.15 If the dip-switches have been set correctly, the burner closest to the manifold (last on branch) should ignite first followed in order by every burner towards the end vent burner.

 Note: It may be necessary to temporarily break the union at a burner in order to purge the gas pipe of air.

3.4.16 Observe the ignition of ALL the burners. An amber neon should illuminate on the rear of the burner when the burner is lighting and remain if the burner has lit. If the burner fails to light, the amber neon will extinguish leaving only the red neon illuminated.

3.4.17 When the branch has been running for 30 minutes, check the end vent vacuum reading at the burner **FURTHEST AWAY**.

Re-adjust the frequency on the inverter as follows:

3.4.18 Press the mode button 3 times until 'ConF' appears on the display. Press the jog dial to enter.

3.4.19 Rotate jog dial until 'HSP' is displayed. Press jog dial to enter.

3.4.20 Rotate jog dial to adjust the frequency on the inverter until the high fire end vent suction is achieved (details of which are given in table 12). Press jog dial to enter new value.

3.4.21 Remove heat demand from system.

3.4.22 Rotate jog dial until 'LSP' is displayed. Press jog dial to enter.

3.4.23 Rotate jog dial to adjust the frequency on the inverter until the low fire end vent suction is achieved.

3.4.24 Return heat demand to system.

3.4.25 Proceed to the next radiant branch closer to the fan and check the end vent vacuum reading at high and low fire.

3.4.26 Adjust the branch damper (if necessary) located at the end of the branch to bring the vacuum readings in line with the normal operating figure shown in table 12. Ensure the damper is locked securely after adjustment.

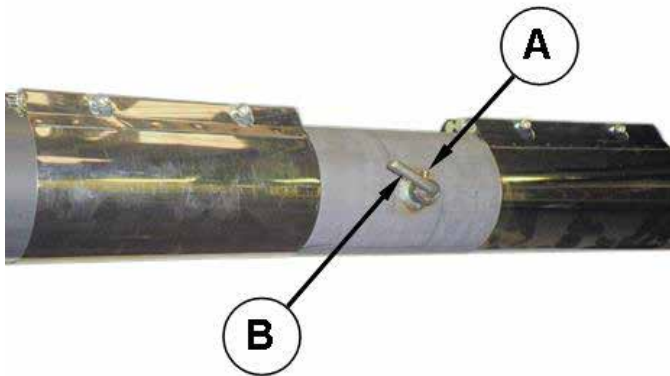

Adjustment instruction for branch damper.

1. Loosen grub screw (A).
2. Turn adjustment lever (B).
3. Position of damper blade is indicated by position of bent adjustment lever.
4. Tighten grub screw (A) to secure damper position.

3.4.27 Repeat procedure 3.4.26 for any further branches (where necessary), moving closer to the fan as each branch is completed.

The vacuum setting procedure is now complete.

3.5 Schneider Inverter Driven B80, B160, B300 Fan, Modulating Branch Damper (Zonal modulation)

In this method, the fan is driven by the inverter and adjusted to give the correct output for full fire.

Modulation is achieved by adjusting each branch damper via a 0-10Vdc input to the damper motor via an external control.

3.5.1 Ensure that electrical supplies to the end vent modules and burners in each branch are connected.

3.5.2 Check that the fan and branch dampers are fully open and secure.

3.5.3 Ensure the controller is in a programmed ON function and above the actual room temperature.

3.5.4 After a 30s delay the fan should run and the inverter should be showing the motor frequency in the display.

3.5.5 Press the mode button 3 times until 'ConF' appears on the display.

3.5.6 Press the jog dial to enter. Rotate jog dial until 'LSP' is displayed. Press jog dial to enter.

3.5.7 Rotate jog dial to adjust frequency. Press jog dial to enter new value, causing the inverter to change its speed.

3.5.8 Adjust the frequency until each burner has lit.

Frequency is usually between 35 and 50 (Hz)

3.5.9 Press the ESC button twice to return the inverter to the 'rdY' display.

3.5.10 Remove power to the system and allow fan to halt.

3.5.11 Return power to system. After a 30s delay the fan should run and a red neon should have illuminated on the rear of each burner.

3.5.12 If the dip-switches have been set correctly, the burner closest to the manifold (last on branch) should ignite first followed in order by every burner towards the end vent burner.

 Note: It may be necessary to temporarily break the union at a burner in order to purge the gas pipe of air.

FOLLOW INSTRUCTIONS ON P39 (3.8) FROM THIS POINT

3.6 Inverter Driven Modulating Fans (BH300 with ABB inverter)

The use of an inverter allows the end vent suction to be adjusted by varying the output speed of the inverter within the local relay unit. This is achieved via a 0-10Vdc input direct to the inverter via an external control.

NOTE: Ensure the modulation input setting in the inverter functions has been adjusted accordingly.

3.6.1 Ensure that electrical supplies to the end vent modules and burners in each branch are connected.

3.6.2 Check that the fan and branch dampers are fully open and secure.

3.6.3 Ensure the controller is in a programmed ON function and set to maximum temperature. (10V dc max from the controller).

3.6.4 After a 30s delay the fan should run and the inverter should be showing the motor frequency in the display.

3.6.5 Set the maximum motor speed parameter 2008 to a Hz value where all the burners light reliably.

Frequency is usually between 35 and 50 (Hz)

3.6.6 Press the '↵' button to return the inverter to the normal display.

3.6.7 Remove heat demand from the system and allow fan to halt.

3.6.8 Return heat demand to system. After a 30s delay the fan should run and a red neon should have illuminated on the rear of each burner.

3.6.9 If the dip-switches have been set correctly, the burner closest to the manifold (last on branch) should ignite first followed in order by every burner towards the end vent burner.

 Note: It may be necessary to temporarily break the union at a burner in order to purge the gas pipe of air.

3.6.10 Observe the ignition of ALL the burners. An amber neon should illuminate on the rear of the burner when the burner is lighting and remain if the burner has lit. If the burner fails to light, the amber neon will extinguish leaving only the red neon illuminated.

3.6.11 When the branch has been running for 30 minutes, check the end vent vacuum reading at the burner

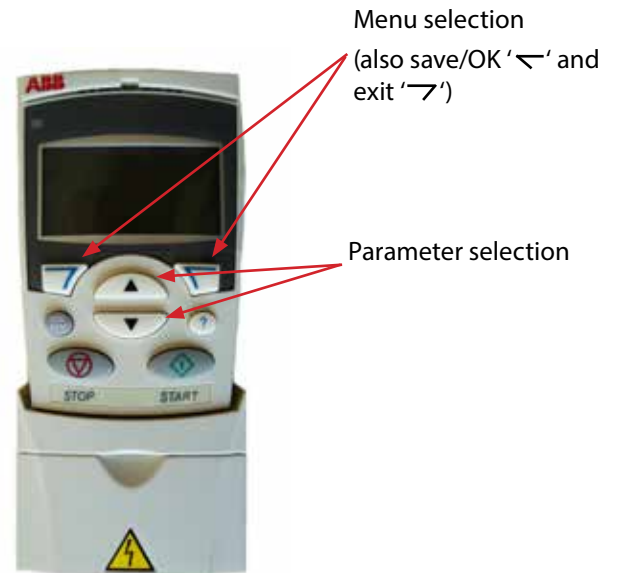

FURTHEST AWAY.

3.6.10 Re-adjust the frequency on the inverter (parameter 2008) until the high fire end vent suction is achieved (details of which are given in table 12)

3.6.11 Remove heat demand from controller.

3.6.12 Set the minimum motor speed parameter 2007 to adjust the frequency until the low fire end vent suction is achieved (details of which are given in table 12).

3.6.13 Reset controller to give heat demand.

3.6.14 Proceed to the next radiant branch closer to the fan and check the end vent vacuum reading at high and low fire.

3.6.15 Adjust the branch damper (if necessary) located at the end of the branch to bring the vacuum readings in line with the normal operating figure shown in table 12. Ensure the damper is locked securely after adjustment.

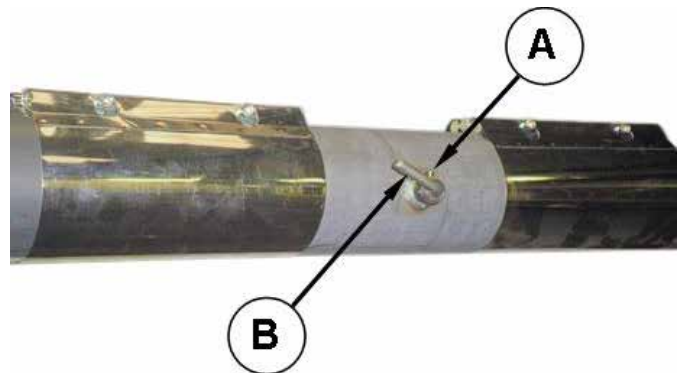

Adjustment instruction for branch damper.

1. Loosen grub screw (A).
2. Turn adjustment lever (B).
3. Position of damper blade is indicated by position of bent adjustment lever.

4. Tighten grub screw (A) to secure damper position.

FOLLOW INSTRUCTIONS ON P39 (3.8) FROM THIS POINT



3.6.16 Repeat procedure 3.6.14 for any further branches (where necessary), moving closer to the fan as each branch is completed. The vacuum setting procedure is now complete.

3.7 ABB Inverter Driven BH300 Fan, Modulating Branch Damper (Zonal modulation)

In this method, the fan is driven by the inverter and adjusted to give the correct output for full fire.

Modulation is achieved by adjusting each branch damper via a 0-10Vdc input to the damper motor via an external control.

3.7.1 Ensure that electrical supplies to the end vent modules and burners in each branch are connected.

3.7.2 Check that the fan and branch dampers are fully open and secure.

3.7.3 Ensure the controller is in a programmed ON function and above the actual room temperature.

3.7.4 After a 30s delay the fan should run and the inverter should be showing the motor frequency in the display.

3.7.5 Set the maximum motor speed parameter 2008 to a value where all the burners light.

Frequency is usually between 35 and 50 (Hz)

3.7.6 Press the '↵' button to return the inverter to the normal display.

3.7.7 Remove heat demand to the system and allow fan to halt.

3.7. Return power to system. After a 30s delay the fan should run and a red neon should have illuminated on the rear of each burner.

3.7.6 If the dip-switches have been set correctly, the burner closest to the manifold (last on branch) should ignite first followed in order by every burner towards the end vent burner.

Note: It may be necessary to temporarily break the union at a burner in order to purge the gas pipe of air.

3.8

3.8.1 Observe the ignition of ALL the burners. An amber neon should illuminate on the rear of the burner when the burner is lighting and remain if the burner has lit. If the burner fails to light, the amber neon will extinguish leaving only the red neon illuminated.

3.8.2 When the branch has been running for 30 minutes, remove the 0-10v signal from the damper and check the end vent vacuum reading at the burner **FURTHEST AWAY**.

3.8.3 Adjust the branch damper by engaging the manual override and rotating the damper spindle until the high fire end vent suction is achieved (details of which are given in table 12). Once the high fire is set, lock the maximum stop in place.

3.8.4 Adjust the branch damper again until the low fire end vent suction is achieved (details of which are given in table 12). Once the low fire is set, lock the minimum stop in place.

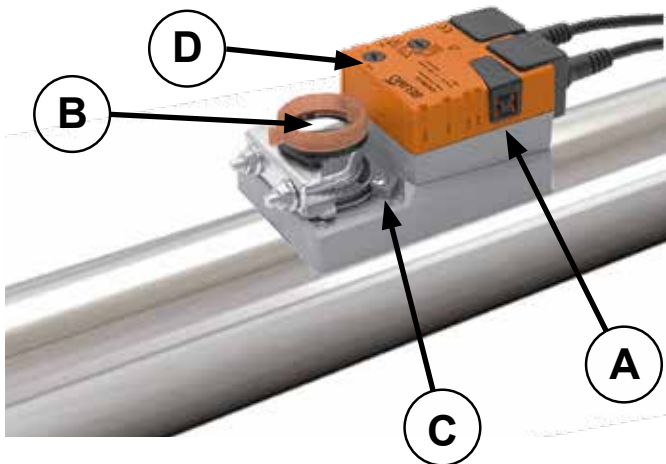

Modulation adjustment instruction for branch damper.

1. Engage manual override by pushing in black button (A).
2. Rotate spindle to achieve correct suction (B).
3. Lock stop in place (C) to secure damper position.
4. Repeat for low fire. Min stop not shown in photo
5. Check correct rotation is selected (D)

3.8.5 Proceed to the next radiant branch closer to the fan and commission in the same manner, observing the ignition sequence of the burners and amber neon's.

3.8.6 Check the end vent vacuum readings, adjusting where necessary.

3.8.7 Repeat procedure above for any further branches (where necessary), moving closer to the fan as each branch is completed.

3.8.8 Re-connect the 0-10Vdc input to the dampers. The vacuum setting procedure is now complete.

3.9 Non-Inverter Driven Fans, Modulating Branch Damper (Zonal modulation)

(fans controlled by NRV 'logic' driven LRU's with no inverter)

End vent vacuum settings are made firstly by means of adjusting the damper at the vacuum fan inlet, this brings the end vent with the lowest reading to the normal operating vacuum.

Modulation is achieved by adjusting each branch damper via a 0-10Vdc input to the damper motor via an external control.

Ensure that all dampers are locked after adjustment.

Ensure that each burner is electrically disconnected at the end vent module plug/socket.

3.9.1 Check vacuum fan inlet and branch dampers are fully open in the first instance and secure.

3.9.2 Ensure the controller is in a programmed ON and above the actual room temperature.

3.9.3 After a 30s delay the fan should run.

3.9.4 Working at the end vent burner **FURTHEST AWAY** from the fan, measure the vacuum pressure and adjust the fan inlet damper to obtain over 8.7 - 10 mbar (above 3.6in wg) **WHEN COLD**.

3.9.5 Remove heat demand from the system and allow fan to halt.

3.9.6 Ensure that each burner is electrically re-connected at the end vent module plug/socket.

3.9.7 Return heat demand to system. After a 30s delay the fan should run and a red neon should have illuminated on the rear of each burner.

3.9.8 If the dip-switches have been set correctly, the burner closest to the manifold (last on branch) should ignite first followed in order by every burner towards the end vent burner.



Note: It may be necessary to temporarily break the union at a burner in order to purge the gas pipe of air.

3.9.9 Observe the ignition of ALL the burners. An amber neon should illuminate on the rear of the burner when the burner is lighting and remain if the burner has lit. If the burner fails to light, the amber neon will extinguish leaving only the red neon illuminated.

3.9.10 When the branch has been running for 30 minutes, disconnect the 0-10V input to the dampers and check the end vent vacuum reading at the burner **FURTHEST AWAY**.

3.9.11 Adjust the branch damper by engaging the manual override and rotating the damper spindle until the high fire end vent suction is achieved (details of which are given in table 12). Once the high fire is set, lock the maximum stop in place.

3.9.12 Adjust the branch damper again until the low fire end vent suction is achieved (details of which are given in table 12). Once the low fire is set, lock the minimum stop in place.

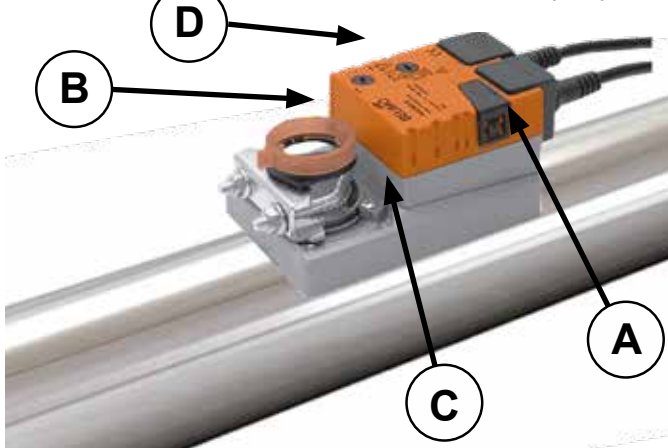

Modulation adjustment instruction for branch damper.

1. Engage manual override by pushing in black button (A).
2. Rotate spindle to achieve correct suction (B).
3. Lock stop in place (C) to secure damper position.
4. Repeat for low fire. Min stop not shown in photo
5. Check correct rotation is selected (D)

3.9.13 Proceed to the next radiant branch closer to the fan and commission in the same manner, observing the ignition sequence of the burners and amber neon's.

3.9.14 Check the end vent vacuum readings, adjusting where necessary.

3.9.15 Repeat procedure above for any further branches (where necessary), moving closer to the fan as each branch is completed.

3.9.16 Re-connect the 0-10Vdc input to the dampers. The vacuum setting procedure is now complete.

3.10 Non-Inverter Driven Fans, Modulating Fan Damper (System modulation)

(fans controlled by NRV 'logic' driven LRU's with no inverter)

End vent vacuum settings are made firstly by means of adjusting the damper at the vacuum fan inlet, this brings the end vent with the lowest reading to the normal operating vacuum.

Modulation is then achieved by adjusting this damper via a 0-10Vdc input to the damper motor via an external control.

Ensure that all dampers are locked after adjustment.

Ensure that each burner is electrically disconnected at the end vent module plug/socket.

3.10.1 Check vacuum fan inlet and branch dampers are fully open in the first instance and secure.

3.10.2 Ensure the controller is in a programmed ON and above the actual room temperature.

3.10.3 After a 30s delay the fan should run. disconnect the 0-10V input to the panel.

3.10.4 Working at the end vent burner **FURTHEST AWAY** from the fan, measure the vacuum pressure and adjust the fan inlet damper by engaging the manual override and rotating the damper spindle until the high fire end vent suction is achieved (details of which are given in the following table). Once the high fire is set, lock the maximum stop in place.

3.10.5 Adjust the fan inlet damper again until the low fire end vent suction is achieved (details of which are given in table 12). Once the low fire is set, lock the minimum stop in place.

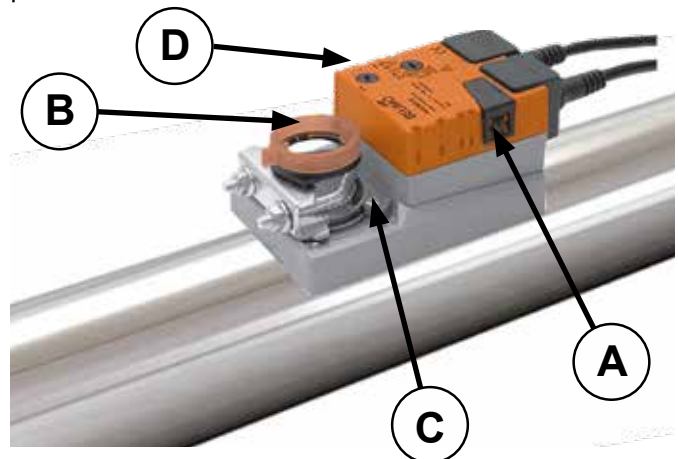

Modulation adjustment instruction for branch damper.

1. Engage manual override by pushing in black button (A).
2. Rotate spindle to achieve correct suction (B).
3. Lock stop in place (C) to secure damper position.
4. Repeat for low fire. Min stop not shown in photo.
5. Check correct rotation is selected (D)

3.10.6 Proceed to the next radiant branch closer to the fan and check the end vent vacuum reading.

3.10.7 Adjust the branch damper (if necessary) located at the end of the branch to bring the vacuum readings in line with the normal operating figure shown in the chart. Ensure the damper is locked securely after adjustment.

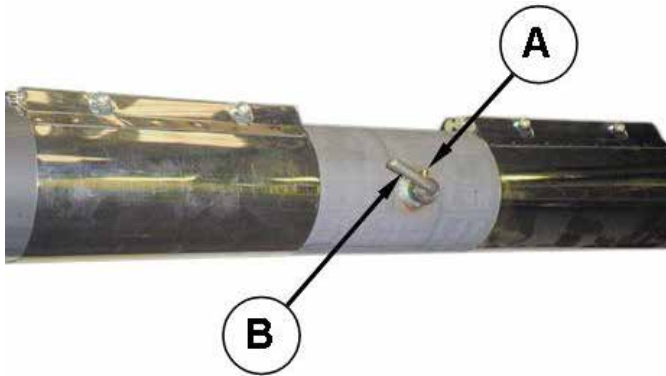

Adjustment instruction for branch damper.

1. Loosen grub screw (A).
2. Turn adjustment lever (B).
3. Position of damper blade is indicated by position of bent adjustment lever.
4. Tighten grub screw (A) to secure damper position.

3.10.8 Repeat for any further branches (where necessary), moving closer to the fan as each branch is completed.

3.10.9 Re-connect the 0-10Vdc input to the dampers. The vacuum setting procedure is now complete.

3.11 Final Commissioning.

3.11.1 Check that the burner injector pressures are **ZERO ± 0.25 mbar** (±0.1in wg). Adjust if necessary.

3.11.2 Check operation of thermostat controllers a number of times, allowing the burner ignition cycle to complete each time, checking that each burner relights.

3.11.3 With all burners firing check the inlet gas pressure at the burner furthest away from the gas supply. The min inlet pressure is 17.5mbar for G20 (Nat Gas), and 25mbar for G31 (Propane). The difference between gas pressure at the burner, with all the burners on and all the burners off should not be more than 2.5 mbar (1in wg).



3.11.4 Take gas consumption meter readings for each separate NRV system or building heated ensuring all other loads are off.

3.11.5 After the system has reached equilibrium: take the following measurements:

- a. The flue gas temperatures entering the vacuum fan. The flue gas sample point located on the vacuum fan tee is used.
- b. The surface temperature of the underside of the tube at the end of each radiant branch.
- c. The surface temperature of the underside of the tube at a point directly underneath each combustion chamber suspension lug.

3.11.6 With the system running, check that under all possible configurations of normal operation, the system functions in accordance with these instructions.

3.11.7 Reset thermostat controllers to required setting.

3.11.8 Complete service report sheet.

Table 12. End Vent Suction/Burner type	mbar HOT	Equivalent burner kW rating			
		24M	32M	38M	46M
@ HIGH fire rate 100%	6.25 mbar	23.0kW	32.0kW	38.0kW	46.0kW
@ 90% Low fire rate*	5.6 mbar	21.6kW	28.8kW	34.2kW	41.4kW
@ 80% Low fire rate*	4.3 mbar	19.2kW	25.6kW	30.4kW	36.8kW
@ 70% Low fire rate*	3.5 mbar	16.8kW	22.4kW	26.6kW	32.2kW
@ 60% Low fire rate*	2.4 mbar	14.4kW	19.2kW	22.8kW	27.6kW
@ MINIMUM LOW fire rate 50%*	1.5 mbar	12.0kW	16.0kW	19.0kW	23.0kW

* Note: Zonal modulation (individual branch damper systems) can have unique low fire rate at the end vents from the list above (50% - 90%). Full system modulation can only have ONE low fire rate from the above list for ALL end vents. In all cases, the high fire rate must be 100%

3.9.1 Typical Unequally Balanced System Layout Modulating controlled via single phase Inverter panel

Table 12. Equivalent burner kW rating

End Vent Suction	100%	mbar HOT	24M	32M	38M	46M
@ HIGH fire rate	32.0kW	6.25 mbar	23.0kW	32.0kW	38.0kW	46.0kW
@ 90% Low fire rate*	21.6kW	5.6 mbar	21.6kW	28.8kW	34.2kW	41.4kW
@ 80% Low fire rate*	19.2kW	4.3 mbar	19.2kW	25.6kW	30.4kW	36.8kW
@ 70% Low fire rate*	16.8kW	3.5 mbar	16.8kW	22.4kW	26.6kW	32.2kW
@ 60% Low fire rate*	14.4kW	2.4 mbar	14.4kW	19.2kW	22.8kW	27.6kW
@ 50% Low fire rate*	12.0kW	1.5 mbar	12.0kW	16.0kW	19.0kW	23.0kW

* Full system modulation can only have ONE low fire rate from the above list for ALL end vents. The high fire rate must be 100%

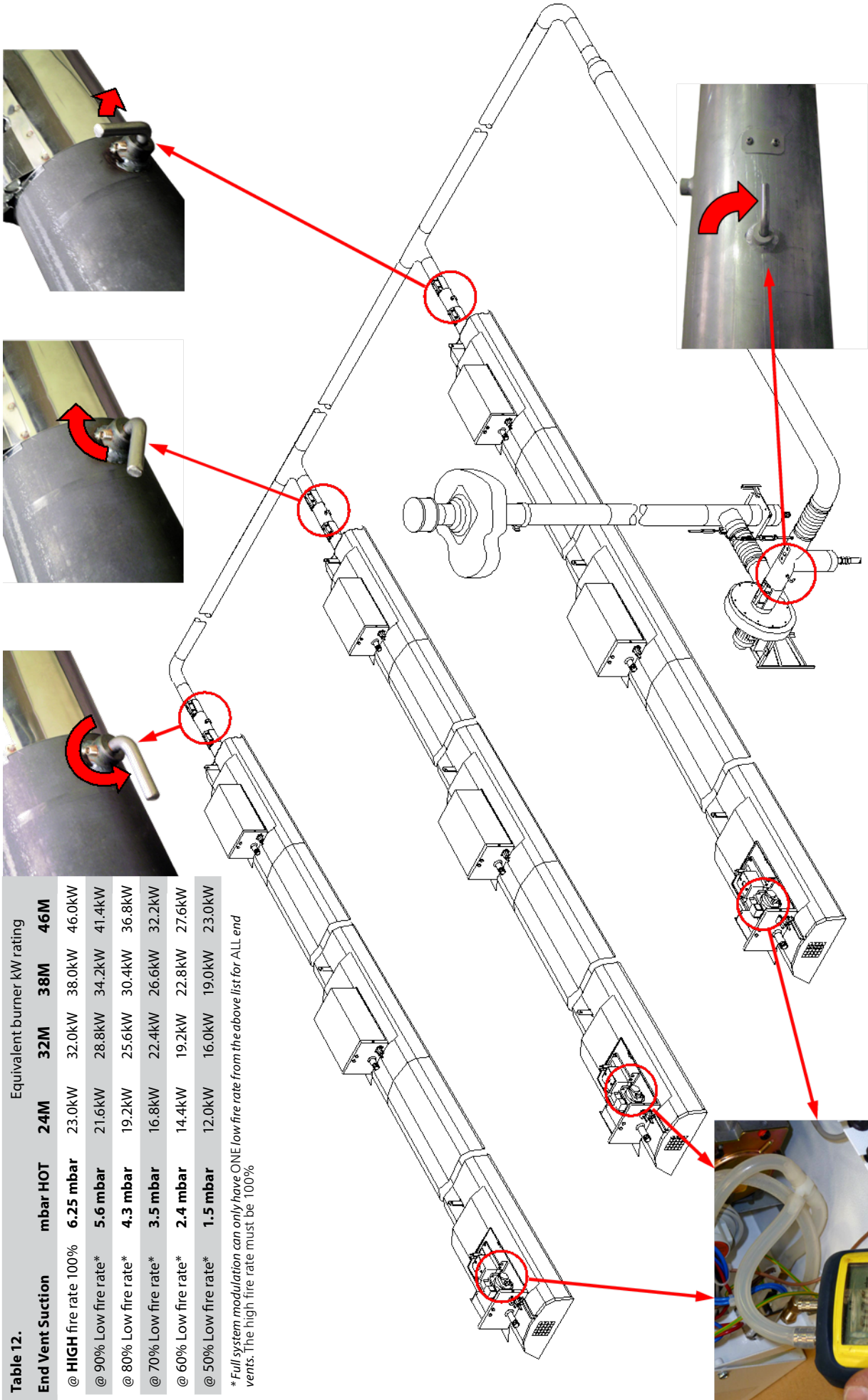

3.9.2 Typical Unequally Balanced System Layout Modulating controlled via zonal branch dampers.

Table 12. Equivalent burner kW rating

End Vent Suction	100%	mbar HOT	24M	32M	38M	46M
@ HIGH fire rate	6.25 mbar	23.0kW	32.0kW	38.0kW	46.0kW	46.0kW
@ 90% Low fire rate*	5.6 mbar	21.6kW	28.8kW	34.2kW	41.4kW	41.4kW
@ 80% Low fire rate*	4.3 mbar	19.2kW	25.6kW	30.4kW	36.8kW	36.8kW
@ 70% Low fire rate*	3.5 mbar	16.8kW	22.4kW	26.6kW	32.2kW	32.2kW
@ 60% Low fire rate*	2.4 mbar	14.4kW	19.2kW	22.8kW	27.6kW	27.6kW
@ 50% Low fire rate*	1.5 mbar	12.0kW	16.0kW	19.0kW	23.0kW	23.0kW

*Note: Zonal modulation (individual branch damper systems) can have unique low fire rate at the end vents from the list above (50% - 90%). The high fire rate must be 100%

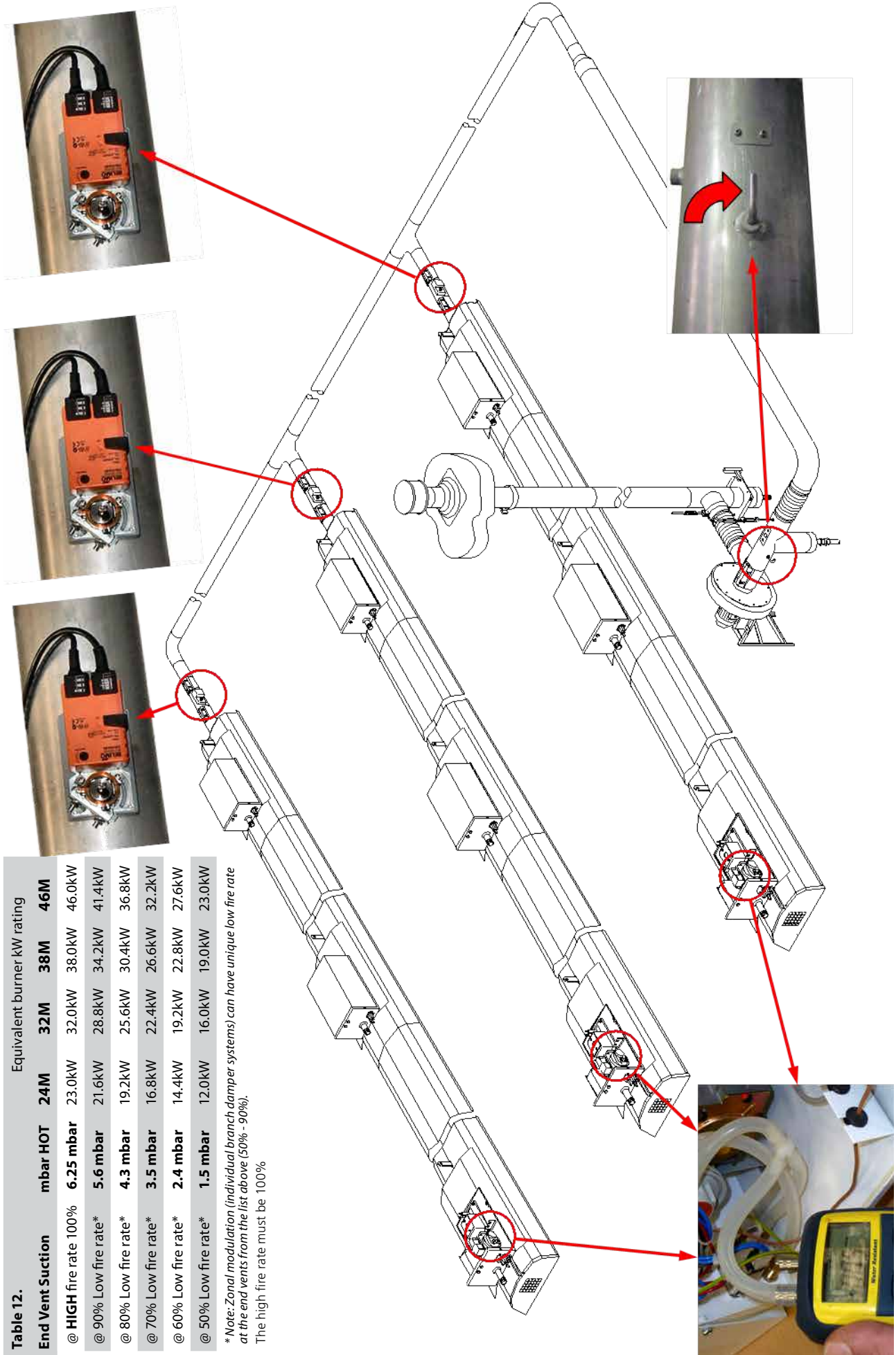

3.9.3 Typical Unequally Balanced System Layout Modulating controlled via system fan damper .

Table 12. Equivalent burner kW rating

End Vent Suction	mbar HOT	24M	32M	38M	46M
@ HIGH fire rate 100%	6.25 mbar	23.0kW	32.0kW	38.0kW	46.0kW
@ 90% Low fire rate*	5.6 mbar	21.6kW	28.8kW	34.2kW	41.4kW
@ 80% Low fire rate*	4.3 mbar	19.2kW	25.6kW	30.4kW	36.8kW
@ 70% Low fire rate*	3.5 mbar	16.8kW	22.4kW	26.6kW	32.2kW
@ 60% Low fire rate*	2.4 mbar	14.4kW	19.2kW	22.8kW	27.6kW
@ 50% Low fire rate*	1.5 mbar	12.0kW	16.0kW	19.0kW	23.0kW

* Full system modulation can only have ONE low fire rate from the above list for ALL end vents. The high fire rate must be 100%.

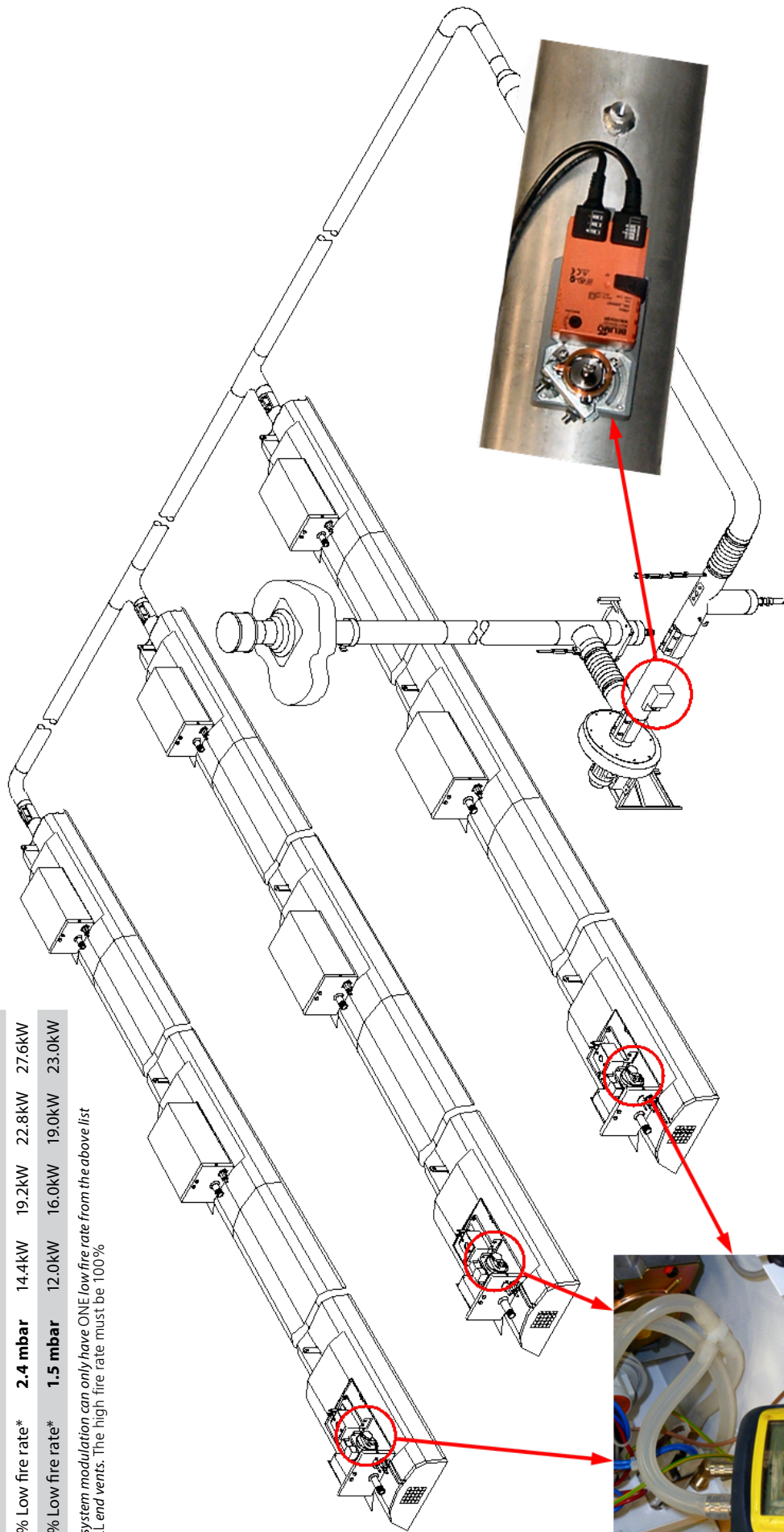

4. Servicing Instructions

 These appliances should be serviced annually by a competent person to ensure safe and efficient operation. In exceptional dusty or polluted conditions more frequent servicing may be required. The manufacturer offers a maintenance service. Details available on request.

4.1 Tools Required.

The following tools and equipment are advisable to complete the tasks laid out in this manual.

 Suitable alternative tools may be used.

4.2 Burner Exploded Views.

Figure 6.a. Burner Head



- 6 Burner head casting – L100103-SUB
- 7 Burner port insert – L100155
- 8 Flame retention grid – L100171
- 9 Air shutter plate - see selection chart
- 10 Burner jet - see selection chart
- 11 Electrode assembly – L100401
- 23 ½" plug – L100202
- 37 Set pin M4 x 6 – 5326-1

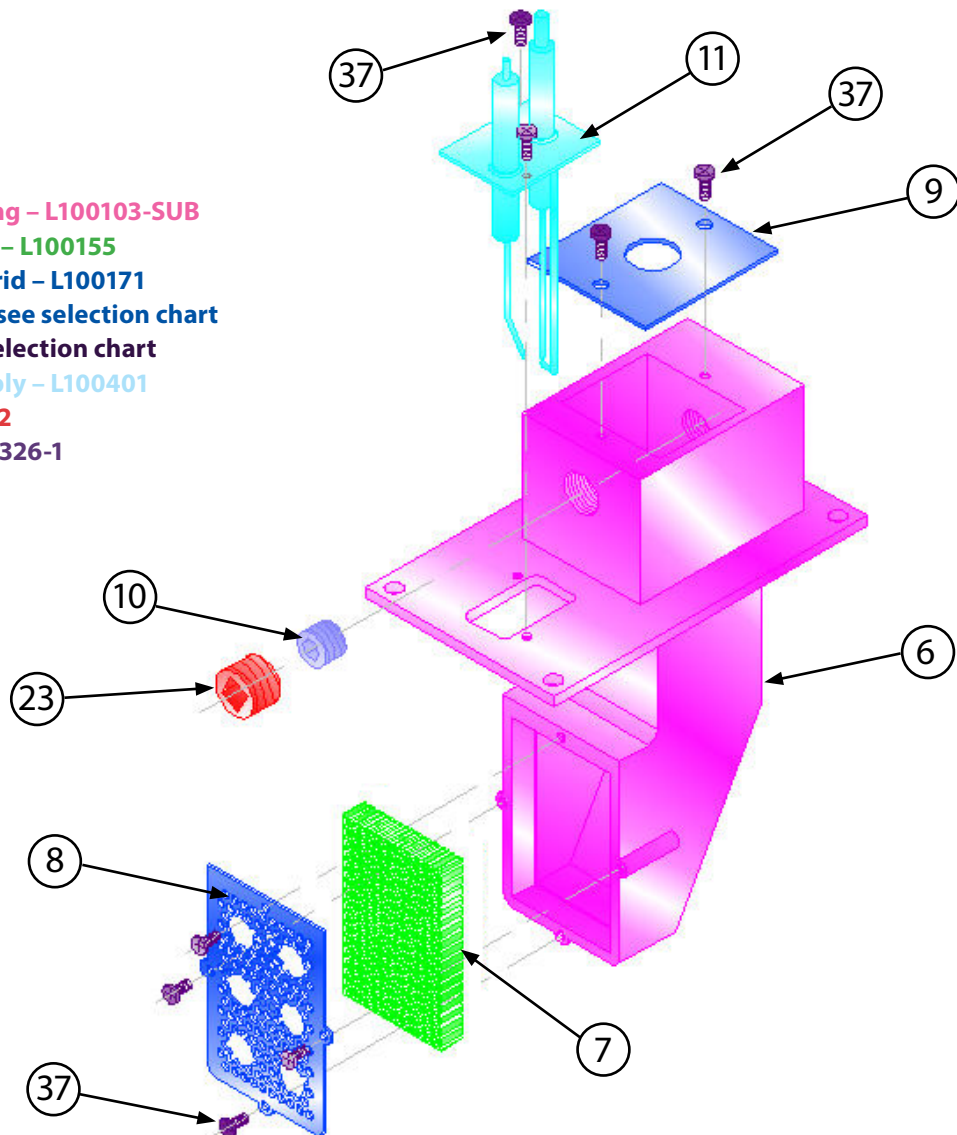
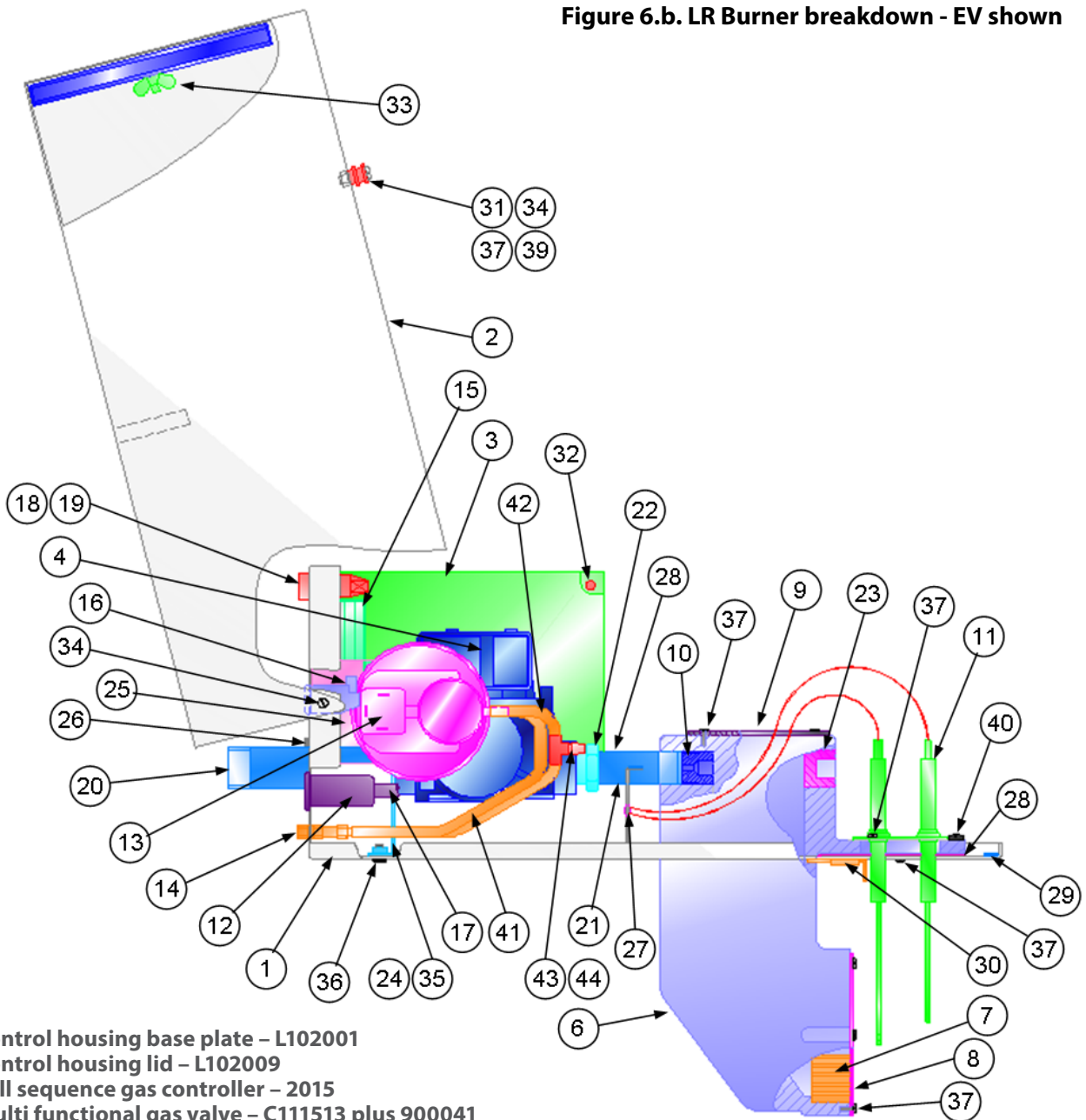

Figure 6.b. LR Burner breakdown - EV shown



- 1 Control housing base plate - L102001
- 2 Control housing lid - L102009
- 3 Full sequence gas controller - 2015
- 4 Multi functional gas valve - C111513 plus 900041
- 5 Air filter - L102013
- 6 Burner head casting - L100103-SUB
- 7 Burner port insert - L100155
- 8 Flame retention grid - L100171
- 9 Air shutter plate - see selection chart
- 10 Burner jet - see selection chart
- 11 Electrode assembly - L100401
- 12 Mains input filter - 201292
- Mains lead (not shown) - 2125
- 13 Air pressure switch (EV only) - 202861
- 14 Bulkhead compression fitting (EV only) - 202861
- 15 Delay timer - L102025-SUB
- 16 Inline Socket (EV only) - 3123-5
- Inline burner plug (EV only - not shown) - 3124
- 17 Wiring harness - E200067
- 18 Red neon light - 2180
- 19 Amber neon light - 2175
- 20 Gas inlet connection pipe 1/2" x 4" - 2360
- 21 Gas outlet inlet connection pipe 3/8" x 2 1/2" - 2314-1
- 22 1/2" x 3/8" reducing bush - 2320
- 23 1/2" plug - L100202
- 24 Valve mounting bracket - L102020
- 25 Pressure switch bracket - L200025

- 26 Grommet (gas supply) - B200500
- 27 Grommet (13mm) - 2878
- 28 Burner gasket - L102032
- 29 Silicone gasket - L102031
- 30 Slide latch - L100200
- 31 Latch clip - L100201
- 32 Push clip - C110714
- 33 Wing nut - C111700
- 34 Set pin M4 x 12 - 5325
- 35 Set pin M4 x 10 - 5314
- 36 Set pin M5 x 10 - 5363
- 37 Set pin M4 x 6 - 5326-1
- 38 Washer M4 - 5322
- 39 Nut M4 - 5315
- 40 Torque Screw - 201093
- 41 Silicone tubing (EV only) - L100180-SUB
- 42 Silicone tubing (EV only) - L100181-SUB
- 43 Plastic tee (EV only) - L104200
- 44 Tee cap (EV only) - L104201
- 45 Three way solenoid air valve (option) - 2197
- 46 Lockout relay - (option) 2104
- 47 Lockout relay base - (option) 2108

4.3 Vacuum fan

Inspect fan and flue ductwork for any contamination.

Inspect expansion joints for damage, replace if necessary.



4.4 Tubes

Inspect radiant tubes and fittings internally. If there is any appreciable build up of dust or deposits the tubes should be cleaned internally.



If corrosion is present replace as necessary.



Note It may be necessary to determine whether chlorinated hydrocarbons are being used by the client.

4.5 Tube couplers

Check for tightness.

Inspect for evidence of holes and cracks, replace if necessary.



4.6 Reflectors

Check for overlaps, re-adjust if necessary. The reflectors may be cleaned with a soft cloth and detergent in water.



4.7 Condensate trap

Inspect for dirt and scale, clean if necessary.



4.8 Igniter assembly (11)

Check ceramic visually for build up of carbon or cracks.

Check the spark distance and position of the electrodes relative to the burner head. Replace if necessary (see fig.7).



4.9 Burner head (6)

Check condition of burner head insert and flame retention grid.

Replace if necessary.



4.10 Filter (5)

Replace if dirty.



4.11 Combustion Chamber Viewing Window

Window should be clean and free from cracks.

Replace if necessary.



4.12 Flue System

Flue needs to be inspected and cleaned if necessary.



⚠ Re-Commissioning system after servicing (see section.3)

**Figure 7.
Burner Electrode Details**

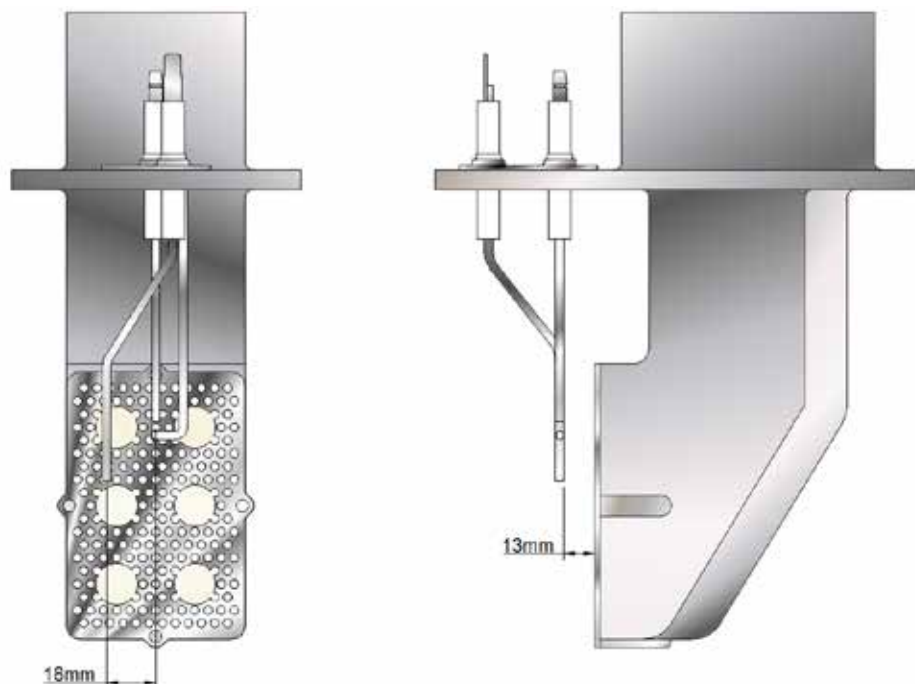

5. Spare Parts.

5.1 Required Spares

In order to aid troubleshooting and servicing, we recommend that the components shown thus (*) in this section should be stocked.

Note: Any spare part components that are not approved by Nortek Global HVAC (UK) Limited could invalidate the approval of the appliance and validity of the warranty.

Only use Smartcom controllers with software version 3.1 or higher.

Refer to fig.6b for parts location.

Item	Description	Part No.	Item	Description	Part No.
	Ignition Controller (3)*	2015		Pressure Switch (13)*	202861
	Gas Valve (4)* Twin Solenoid 220/240*	C111513		Amber Neon (19) (Burner On)	2175
	Valve Mini Harness	900041		Red Neon (18) (Mains On)	2180
	Mains Inlet Socket (12)	201292		Inline Burner Socket (16)	3123-5
	Igniter Assembly (11)*	L100401		Inline Burner Plug (16b)	3124
	Ignition HT Lead*	2243-1		Vacuum Test Nipple (43)	L104200
	Rectification Lead*	2125		Delay Timer (15)*	L102026
	Mains Input Cable (12b)	2125		Main Harness (17): End Vent In-line	E200067 E200068
	Burner Air Filter (5)*	L102013		Lockout Relay (46) (option)	2104
	Webber Valve (43) (option)	2197		Relay Base (47) (option)	2108

Item	Description	Part No.	Item	Description	Part No.
	Burner Gasket (27)*	L102032		Burner Head Assy (6)	L100102-SUB
	Ceramic Insert (7)	L100155		Flame Retention (8)	L100171
	Mica Window (52)	A523500		Sight Glass Cover (50)	A571202
	Window Gasket (51)	C110350		End Vent Module	EVM
	B80 Fan	201760		Inverters:	
	B160 Fan	201761		1.5kW B80/B160	900091
	B300 Fan	201762		2.2kW B300	900090
	BH300 Fan	201763		BH300 keypad	N1886* N1886-1*
	100mm (4") Tube Coupler	C112110		Contactor O'load BH300 DOL Only	6129 6131-7
	150mm (6") Tube Coupler	C112120		Fan Expansion Joint	7532
	Combustion Chamber	L101020-SUB		Jubilee Clip	7542
	Combustion Chamber Reflector	L105050		Suspension Bracket	C110500-SUB
	Standard Reflector	L105024		Reflector Support Bracket	L201008-SUB
				Speedlinks	6524

*Must be ordered together

5.2 NRV 'M' Injector/Air Shutter selection chart



Gas Type	Burner	Jet (10) size dia mm / Part No.	Shutter (9) size dia mm / Part no.	EVM Orifice Plate dia mm / Part no.
Natural Gas G20	24	4.9 / L100549	19.5 / L100320	24 / L104100
	32	5.4 / L100554	22 / L100314	27 / L104093
	38	5.8 / L100558	24 / L100316	32 / L104092
	46	6.3 / L100563	26.5 / L100318	- / -
Propane Gas G31	24	4.0 / L100540	19.5 / L100320	24 / L104100
	32	4.4 / L100544	22 / L100314	27 / L104093
	38	4.8 / L100548	24 / L100316	32 / L104092
	46	5.2 / L100552	26.5 / L100318	- / -

6. Fault Finding Guide.

Symptoms	Possible causes	Remedy
Vacuum fan is running but there is no power at burner. Neon lights are off.	Thermostat is satisfied.	Check to see that thermostat is calling for heat.
	No power at burner.	Check for 240V supply.
	Blown fuse in supply to heater.	Check and replace if necessary.
	End vent vacuum too low.	Vacuum at end vent should be 6.25 mbar (2.5in wg). Check for air leaks on burner.
	Air pressure switch on end vent burner not opening.	Check and replace if necessary.
	3 way air valve (if fitted) in end vent burner not opening.	Check and replace if necessary.
	No power out from end vent burner.	Check for loose or broken wire or faulty relay.
Red neon comes on but ignition sequence does not start and amber neon remains off.	Loose or broken leads to sequence gas controller.	Check and repair.
	Fault in full sequence gas controller.	Replace.
Red neon comes on. Amber neon comes on for ignition period; then amber neon goes off.	No ignition spark.	Check for loose or broken high tension lead to spark electrode. Check spark gap and position for spark electrode. Check ceramic is not cracked. Check for loose earth wire connection on sequence gas controller.
	Fault in full sequence gas controller.	Replace.
	Insufficient gas supply to burner.	Check service cock is open and gas pressure is available at inlet to gas valve.
	Gas solenoid valve not opening.	Check for loose or broken wires to the gas valve. Check for adequate end vent vacuum. Replace valve if necessary.
	Injector pressure not set at zero.	Check and adjust.
	Incorrect aeration.	Check that air shutter plate on mixing chamber is correctly positioned.
	Red neon comes on. Amber neon comes on for ignition period, burner lights for a short time and then goes out. Amber neon off.	Flame probe faulty or lead detached.
Fault in sequence gas controller.		Measure flame current. The minimum signal is 3µA (DC).
Polarity of line and neutral incorrect.		Check for correct polarity of the electrical supply.
Burner earth is poor.		Check and ensure burner is correctly earthed.
Full sequence gas controller faulty.		Replace.
Incorrect aeration.		Check that air shutter plate on mixing chamber is correctly positioned.
End vent vacuum too low (ie below 6.25 mbar (2.5in wg). Check section 3, commissioning for exact vacuum details.		Branch damper closed or broken.
	Fan rotation incorrect.	Reverse two phase wires on 3 phase motors.
	Fan speed wrong.	Check voltage at motor. Replace if necessary.
	Fan impeller loose or defective.	Tighten or replace if necessary.
	Restriction to fan inlet.	Clear restriction, repair flue duct.
	Air leaks into system via poor joints.	Replace defective tube couplers, gaskets or acoustic joints.
	Insufficient fall of system towards fan allowing condensate blockage.	Reinstate system fall.
	Non return valve sticking open on condensate trap assembly.	Clean valve or replace if damaged.

7. Replacing Parts.



7.1 Removal of burner assembly.

a: Disconnect electrical supply at burner mains inlet connection.

b: Turn-off gas supply at service cock and disconnect union.
b1 On EVM burners, remove the vacuum tubes by releasing the two compression fittings (14).

c: Release the slider latches (30) from the underside of the burner base plate (1).



d: Pull lid (2) apart and upwards from base (1). Lid is attached to back plate via 2 screws (34).

e: Remove lid by unscrewing set pins (34) from back of base plate.

f: Remove spark electrode assembly (11) (see section 7.6)

g: Release and remove the four set screws (40) from the combustion chamber flange.

Retain combustion chamber gasket (28).



h: Lift burner clear of combustion chamber and withdraw.

i: Remove the burner heat shield.

j: When replacing do so in the reverse order ensuring that the gasket between the burner heat shield and combustion chamber (28) is undamaged or replace if necessary.

k: Check for gas soundness.



7.2 Controller (3) Replacement

a: Disconnect electrical supply.

b: Release the slider latches (30) from the underside of the burner base plate.

c: Pull lid (2) apart and upwards from base (1).

d: Disconnect wiring loom connections from controller (3a).



e: Disconnect ignition wire from controller (3b)



f: Release three push clips (32) from controller fixing holes.

g: Remove controller (3)

h: Replace in reverse order.



7.3 Removal of Gas Valve (4).

a: Remove burner assembly from combustion chamber as detailed in 7.1.

b: Remove controller (3) as described in 7.2

c: Remove Igniter assembly (11) as detailed in 7.6

d: Disconnect earth cable from valve body.

e: Secure burner head (6) and unscrew gas inlet connection.

f: Remove burner casting securing set screws (37)



g: Remove valve bracket set screws (36) from the underside of burner base plate.

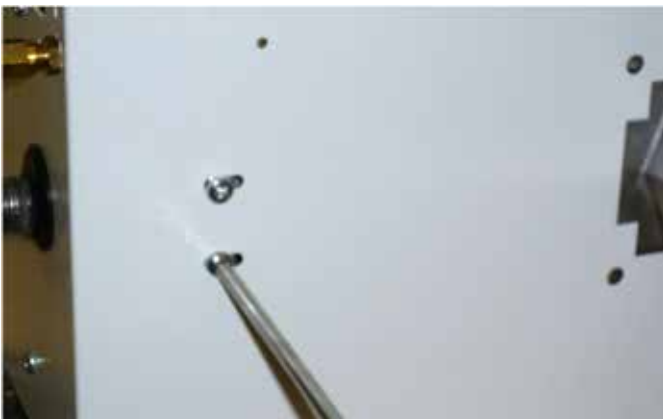

h: Withdraw burner head and valve assembly from base plate.

Retain burner gasket (28) for later.

j: Secure burner head (6) and unscrew gas valve (4).



k: Replace in reverse order.



7.4 Filter (5) Replacement.

a: Release the slider latches (30) from the underside of the burner base plate (1).

b: Pull lid (2) apart and upwards from base (1).

c: Unscrew wing nut fastener (33).



d: Slide filter (5) out of location brackets.

e: Replace in reverse order.



7.5 Pressure Switch (13) Replacement (EVM ONLY).

- a: Disconnect electrical supply.
- b: Release the slider latches (30) from the underside of the burner base plate.
- c: Pull lid (2) apart and upwards from base (1).
- d: Disconnect both silicone tubes (42 & 43) from pressure switch (noting positions).
- e: Disconnect three electrical cables from pressure switch (noting positions).
- f: Remove fixing screws and nuts from the pressure switch bracket and withdraw.
- g: Remove retaining screws from bracket to pressure switch and remove unit.



- h: Replace in reverse order.



7.6 Delay Timer (15) Replacement.

- a: Disconnect electrical supply.
- b: Release the slider latches (30) from the underside of the burner base plate.
- c: Pull lid (2) apart and upwards from base (1).
- d: Remove controller as described in section 7.2

- e: Disconnect electrical connections from the timer.

- f: Remove fixing screws from timer bracket and withdraw.



- g: Replace in reverse order.



7.6 Igniter Assembly (11) Replacement.

- a: Disconnect electrical supply.
- b: Release the slider latches (30) from the underside of the burner base plate.
- c: Pull lid (2) apart and upwards from base (1).
- d: Remove probe lead (46)
- e: Remove fixing screws (37) from electrode mounting flange (11).



- f: Carefully withdraw electrode assembly from burner - noting electrode orientation.

g: Replace in reverse order.



7.7 Injector (10) Replacement.

(See figure 6a)

a: Turn off gas and disconnect electrical supply.

b: Release the slider latches (30) from the underside of the burner base plate (1).

c: Pull lid (2) apart and upwards from base (1).

d: remove fixing screws (37) and air shutter plate (9) from top of burner casting.

e: Remove plug (23).



f: Unscrew brass jet (10) inside mixing chamber using 8mm allen key and withdraw through 1/2in BSP hole.

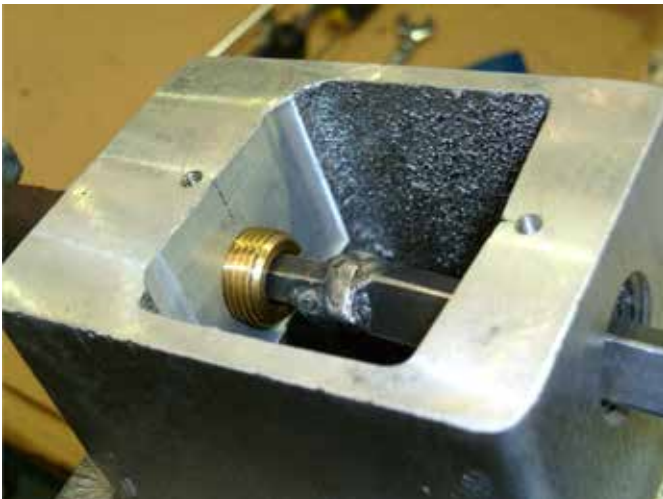

g: Replace in reverse order.



7.8 Combustion Chamber Viewing Window Replacement.

a: Turn off the system including the vacuum fan.



b: Unscrew dome nuts (53) remove spring washers (54). Remove sight glass cover (50), gasket (51) and mica window (52).

c: Replace in reverse order as shown ensuring components are re-assembled in correct order.



Notes

8. User & Operating Instructions.

8.1 To Start the Heater

1. Ensure that gas supply is turned on at each burner.
 2. Switch on electrical supply to heaters.
 3. Ensure that the following controls are correctly set i.e.;
- * Clock.
 - * Heater program.
 - * Required room temp.
4. The vacuum fan will operate and at the same time the red neon lights will illuminate at all burners. After 10 seconds the burners closest to the exhaust fan in each radiant branch will light, with both red and amber neons illuminated. After a further 25 seconds the next burner in line within each radiant branch will light and after a further 25 seconds the end vent burner will light.
 5. If the lighting up sequence fails and lockout occurs, press the lockout reset button (if available), or switch off the electrical supply and restart after 40 seconds. If lockout occurs three times consecutively switch off and isolate the gas and electricity supplies.

Contact the Nortek Global HVAC (UK) Limited Service department (details below).

8.2. To Switch Off Heater

1. Switch off electrical supply to the heater. The burner will stop and the fan will shut off.
2. If the heater is to be switched off for periods in excess of one week it is highly recommended that both the gas and the electrical supplies are turned off.

8.3. Routine Maintenance between Service Intervals

After ensuring that the heater is cold and mains electric isolated, cleaning of the reflectors with a soft cloth and a mild detergent (non solvent based cleaners only) in water can be undertaken.

Additional removal of dust from the radiant tubes, burner and heat exchanger can be undertaken.

8.4 Frequency of Servicing

The manufacturer recommends that to ensure continued efficient and safe operation of the appliance, the heater is serviced annually by a competent person e.g. every year in normal working conditions but in exceptional dusty or polluted conditions more frequent servicing may be required.

The manufacturer offers a maintenance service.

Details are available on request.

For Service requirements, please contact Nortek Global HVAC (UK) Limited (details below).

For further technical and service support visit our Support Information Database at www.s-i-d.co.uk



Note This notice must be fixed alongside the electrical service switch.



Nortek Global HVAC is a registered trademark of the Nortek Global HVAC limited. Because of the continuous product innovation, Nortek Global HVAC reserves the right to change product specification without due notice.

NORTEK GLOBAL HVAC (UK) LTD

Fens Pool Avenue
Brierley Hill
West Midlands DY5 1QA
United Kingdom
Tel +44 (0)1384 489700
Fax +44 (0)1384 489707
reznorsales@nortek.com
www.reznor.eu

This document replaces the previous manual, part no: Reznor, NRV, M Installation Manual, EN 2020-05, D301040 Iss C
Current full Part No. **Reznor, NRV, M Installation Manual, EN 2022-01, D301040 Iss D**