

AMBIENT, LPHW AND ELECTRIC HEATED GUARDIAN GB, GR AND GS COMMERCIAL AIR CURTAIN RANGE



INSTALLATION MANUAL



BS EN ISO 12100:2010 Safety of machinery.

BS EN 60204-1:2018 Safety of machinery. Electrical equipment of machines.

BS EN 55014-1:2017 Electromagnetic compatibility.

BS EN 60335-2-30:2009+A11:2012 Safety. Requirements for room heaters to the following European CE directives- 2006/95/EC - low voltage; 2014/30/EU - electromagnetic compatibility

Please read this document carefully before commencing installation, commissioning and/or servicing.
Leave it with the end user/site agent to be placed in their premises technical file after installation.

WARNING

Improper installation, adjustment, alteration, service or maintenance can cause property damage, injury or death.

All work must be carried out by appropriately qualified persons.

The manufacturer does not take any responsibility in the event of non-observance of the regulations concerning the connection of the apparatus causing a dangerous operation possibly resulting in damage to the apparatus and/or environment in which the unit is installed.

Contents

General Information (G)

Guardian air curtain range	4
General product information.....	4
Health and safety	4
Requirements	5
Clearance distances	5
Electrical	5
SmartElec controller	5
Important notice to installers	5
Using this manual	5

Technical Data (TD)

Technical data	6
Fuses	7
Dimensions. GS Surface mounted models	8
Clearance distances	8
Dimensions. GR Recessed models.....	9
Clearance distances	9
Dimensions. GB Bulkhead mounted models	10
Clearance distances	10
Program panel dimensions	11
Component layout	12
LPHW coil technical data	37

Installation (I)

Installation	13
Mounting	13
Electrical supply	13
Installation process	14
Suspending on threaded rods	15
Wall mounting bracket	15
Installation details - LPHW Only.....	16
Program panel	17
Standard and high capacity fan & heat settings	18
Fan speed setting	18
Ambient and LPHW model.....	18
Wiring diagrams	19
Installer wiring Ambient single phase	19
Protection	19
Installer wiring Electric heated three phase only	20
Protection	20
Installer wiring LPHW single phase	21
Protection	21
Optional wiring.....	22

Controller (C)

Networking.....	22
Air curtain addressing	22
Power-up manual reset	23
Ambient & LPHW models.....	23
Standard settings	23
Engineers settings.....	24

Door link settings.....	24
Link-group interlock.....	24
All controllers.....	24
External temperature	24
External temperature offset.....	24
Temperature limits	25
Air return & pipe cold sensors	25
Electric Heated models.....	25
Keypad display.....	25
Normal mode displays.....	25
Normal operation.....	25
OFF mode	25
Settings mode.....	25
Settings display	26
Setup configurations.....	26
Set fan speed.....	26
Set temperature.....	26
Networked air curtains.....	26
Engineer settings	26
Door link settings	26
Link-group lockout.....	27
External temperature	27
External temperature offset.....	28
Temperature limits	28
keypad sequences.....	28
Modbus protocol	29
Modbus address	29
Modbus function codes supported.....	29

Maintenance & servicing (MS)

Maintenance and servicing.....	31
Inlet foam filter replacement GS.....	31
Inlet foam filter replacement GR	32
Honeycomb outlet replacement	32

Fault Finding (FF)

Fault finding	33
General.....	33
Electrically heated units only.	33
Program panel	33
SmartElec fault codes.....	34

Spare Parts (SP)

Spare parts	35
General.....	35

Parts Replacement (PR)

Parts replacement	36
Control panel	36
Heating element	36
Fan deck.....	36

Guardian air curtain range

General product information

Models

- GS Surface mounted model
- GR Recessed mounted model
- GB Bulkhead mounted model

Three sizes

- 1000mm
- 1500mm
- 2000mm

Three variations

- Ambient (not heated)
- Electrically heated
- LPHW (low pressure hot water)

The new design allows for quick and easy access to the control panel and the installers terminal block, the GS range has two access panels on the 1000, three on the 1500 and four on the 2000. The GR has hinged access panels which can be removed with ease

Electric heated versions require a three phase (415v) electrical supply, whilst all other versions need a single phase (230v) supply

All units have fans capable of providing standard & high capacity air duties. Electric & LPHW also offer standard & high capacity heating outputs.

Units are designed for versatile installation, options of wall mounted, recessed within a false ceiling, fitted in a bulkhead, or on drop rods in front of glass fronted entrances.

A wall mounting bracket is available as an optional extra. Units can be mounted adjacent to each other to cover the full door opening across wider entrances.

All models are supplied with a program panel and 10m length of RJ45 communication cable. The program panel allows the user to control either a single air curtain, or a network of up to 16 air curtains.

Easy programming the end users simply select whether they require the heat on or off (not ambient models), the required fan setting (1,2 or 3 speed), and the outlet temperature setting

Options for BMS compatible via Modbus communication can be linked to optional external thermostat for proportional control in various set temperatures

Health and safety

Before installing, carefully read the instructions and follow the processes explained by the manufacturer

Check that the temperature ranges given and those of the location match. The appliance must be powered with a voltage corresponding to the value shown on the rating plate.

Ensure that anchoring points are suitable for the weight and loading of the product and if required, add suitable reinforcement to the anchoring points area.

Installing, programming, commissioning, and maintenance of these products must only be carried out by suitably qualified and trained technicians and in full compliance of all applicable regulations and current best practices.

Due consideration should be taken for workplace safety, risk assessments and waste disposal.

Any modification of the product may be hazardous and the manufacturer is not liable for any damage or injury caused by improper use

Requirements

Clearance distances

For installation and maintenance clearances, please see the information on page 8 for the GS models, page 9 for the GR models and page 10 for the GB models.

Electrical

For full electrical loadings, please refer to the technical data section on page 6 of this manual.

It is recommended that the electrical supply to the base unit in the air curtain is via an appropriate switched isolator, fitted in accordance with the regulations in force in the country of use and must be via a fused isolator having a contact separation of greater than 3mm in all poles.



For safety reasons a good earth connection must ALWAYS be made to the heater and control box.

SmartElec controller

Electric heated models have a supply requirement of 415V 3 phase, neutral and earth. Maximum cable inlet size is 10mm².

Program panel is wired to the control base unit via a RJ45 pre-wired cable.

Networked air curtain interconnects via a RJ45 pre-wired cable

Important notice to installers



Before installation, check the local distribution conditions, supply voltage and nature of water and pressure (LPHW), are compatible.



Installation, assembly, commissioning, service and maintenance procedures must be carried out only by suitable competent qualified persons. Unauthorised modifications to the appliance, or departure from the manufacturer's guidance on intended use, or installation contrary to the manufacturer's recommendations may constitute a hazard.

Note

To ignore the warning and caution notices, and to ignore the advice from the manufacturer on installation, commissioning, servicing, or use, will jeopardise any applicable warranty, such a situation could also compromise the safe and efficient running of the appliance itself, and thereby constitute a hazard.

Using this manual

Contained within the text of the manual, the symbols for 'Caution' and 'Warning' these are used to highlight certain points.



Caution is used when failure to follow or implement the instruction(s) can lead to premature failure or damage to the unit or its component parts.



Warning is used when failure to heed or implement the instruction(s) can lead to not only component damage, but also to a hazardous situation being created where there is a risk of personal injury.

Technical data

TD

Data	Fan speed	Unit	1000	1500	2000
All models					
Maximum door width	L, M, H	m	1.0	1.5	2.0
Maximum mounting height standard capacity	L, M	m	3.0		
Maximum mounting height high capacity	H	m	4.0		
Maximum air volume	L	m ³ /h	1150	1730	2300
	M	m ³ /h	1440	2270	2880
	H	m ³ /h	1800	2700	3600
Maximum velocity at 0 metre	L	m/s	6.4		
	M	m/s	8	8.4	8
	H	m/s	10	10.1	10
Maximum velocity at 1 metre	H	m/s	5.6	5.2	5.4
Maximum velocity at 2 metre	H	m/s	3.8	3.5	3.7
Maximum velocity at 3 metre	H	m/s	2.8	2.5	2.8
Motor power	L, M, H	W	365	530	730
Noise level @ 3m free field	L	dB(A)	52		
	M	dB(A)	55		
	H	dB(A)	59		
Program panel control wiring			RJ45 (pre-wired cable required)		
Cable terminal size			1.5mm ² MAX		
Electric Heated Models					
Electrical supply	L, M, H		415V 3 phase 50Hz		
Heating capacity - standard	L, M, H	kW	9	12	18
Heating capacity - high	L, M, H	kW	12	18	24
Total electrical load -per phase standard	L	A	13.7	18.3	27.4
	M	A	13.8	18.4	27.7
	H	A	13.8	18.5	27.8
Heat current per phase standard	L	A	12.53	16.78	25.08
	M	A	12.51	16.66	25.05
	H	A	12.44	16.53	25.00
Total electrical load -per phase high	L	A	17.9	26.6	35.7
	M	A	18.0	26.8	36.0
	H	A	18.0	27.0	36.2
Heat current per phase high	L	A	16.73	25.08	33.38
	M	A	16.71	25.06	33.35
	H	A	16.64	25.03	33.40
Temperature rise - Standard (No Jumpers 9/12/18kW)	L	°C	28	27	27
	M	°C	23	24	23
	H	°C	18	17	19
Temperature rise - High (Jumpers in 12/18/24kW)	L	°C	34	33	33
	M	°C	29	28	29
	H	°C	24	22	24
Weight	L, M, H	kg	34.5	52	64.5
External fuse size (D type MCB)	H	A	20	32	40

Ambient Models					
Electrical supply	L, M, H		230V single phase 50Hz		
Total electrical load	L	A	1.17	1.52	2.32
	M	A	1.29	1.74	2.65
	H	A	1.36	1.97	2.8
Weight	L, M, H	kg	32	48.5	60
External fuse size (D type MCB)	H	A	6		
LPHW Heated Models					
Electrical supply	L, M, H		230V single phase 50Hz		
Maximum heating capacity standard	L, M, H	kW	9	12	18
Maximum heating capacity high	L, M, H	kW	12	18	24
Total electrical load	L	A	1.17	1.52	2.32
	M	A	1.29	1.74	2.65
	H	A	1.36	1.97	2.8
Temperature Rise - Standard (9/12/18kW)	L	°C	28	27	27
	M	°C	23	24	23
	H	°C	18	17	19
Temperature Rise - High (12/18/24kW)	L	°C	34	33	33
	M	°C	29	28	29
	H	°C	24	22	24
Weight (incl water)	L, M, H	kg	38.5	58	72
External fuse size (D type MCB)	H	A	6		

Table 1 Technical data

Standard Capacity is the factory default. High Capacity is achieved by using the Jumpers provided in the installation pack, (see parts table on page 35) and additional information on standard and high capacity fan and heat settings on page 18, Standard = default heating capacity.

High = jumpers fitted in terminals 1a to 6a selectable by installer

LPHW kW ratings based upon a flow & return water temperature of 82/72°C

Fuses

All of the circuit boards in the Guardian air curtain range have a control fuse T1H which covers the fans. The electric model with the SmartElec board has two additional large fuses to protect the heating elements. F2 and F3

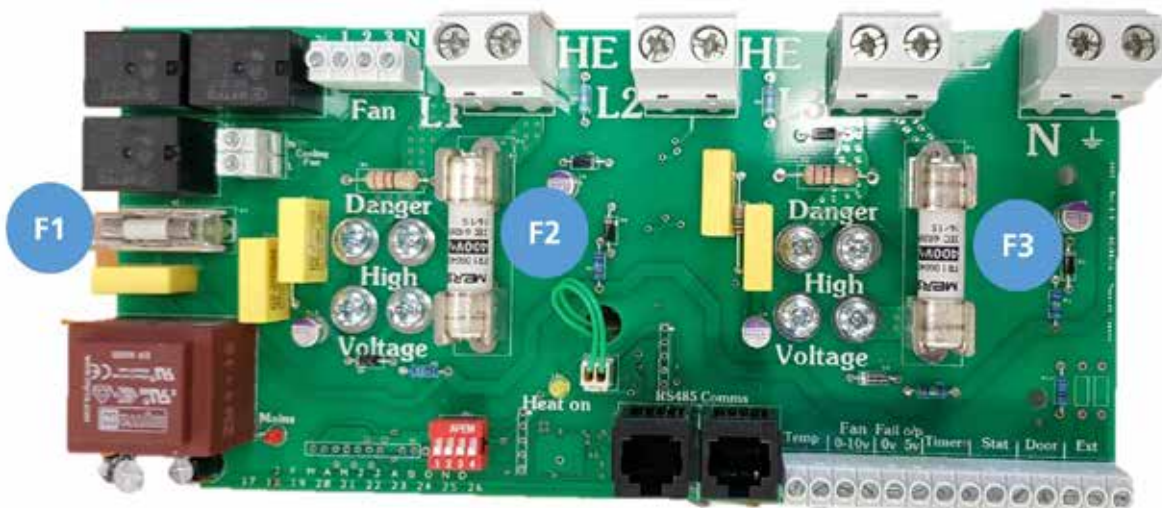

Figure 1 Fuse location electric model board shown

Dimensions. GS Surface mounted models

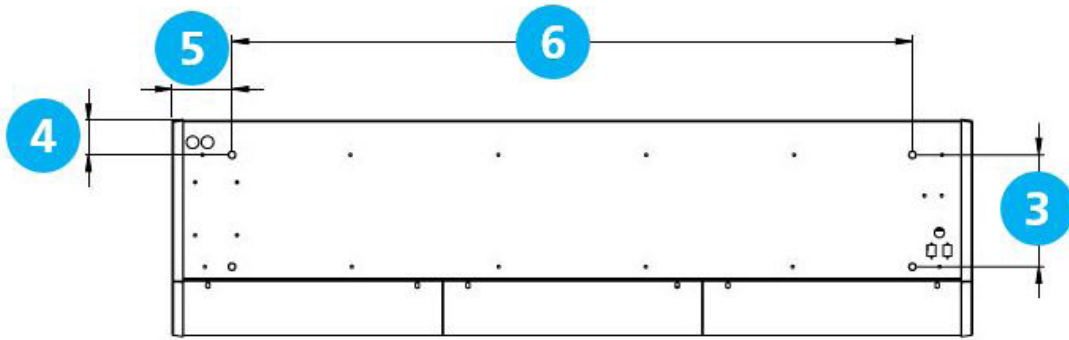

Figure 2 GS Top view

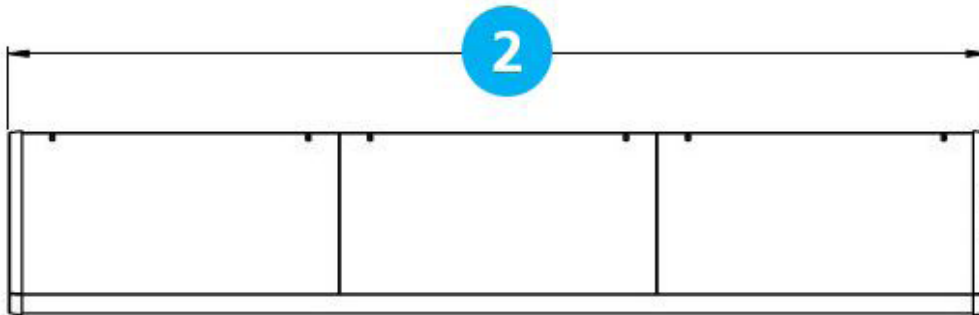

Figure 2.1 GS Front view



Figure 2.2 GS Bottom view

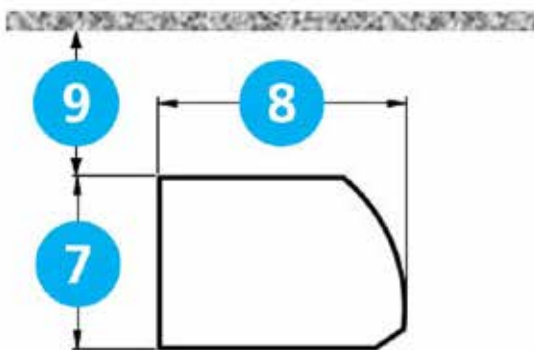

Figure 2.3 GS Side view

Reference	GS 1000	GS 1500	GS 2000
1	440		
2	1094	1620	2148
3	227		
4	70		
5	132	130	132
6	830	1360	1884
7	306		
8	440		
9	>100		

Table 2 GS dimensions

Clearance distances

It is recommended that a minimum clearance of 100mm is allowed around the top and front of the unit. The clearance allows for cable entry and prevents combustible surfaces overheating.

The minimum mounting height (floor to grille outlet) is 1.8m. The recommended maximum mounting height is 3m for standard fan setting & 4m for high

Dimensions. GR Recessed models

TD

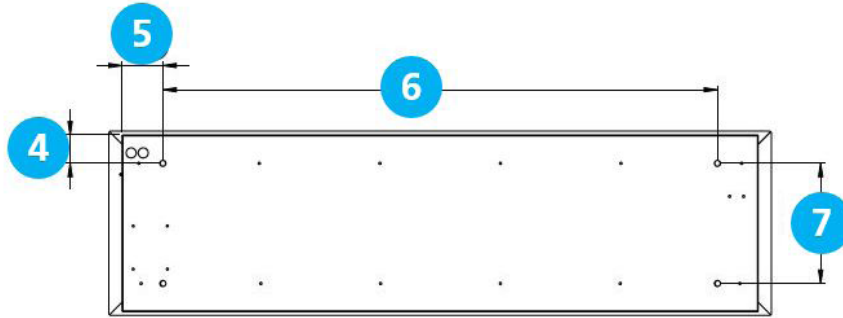

Figure 3 GR Top view

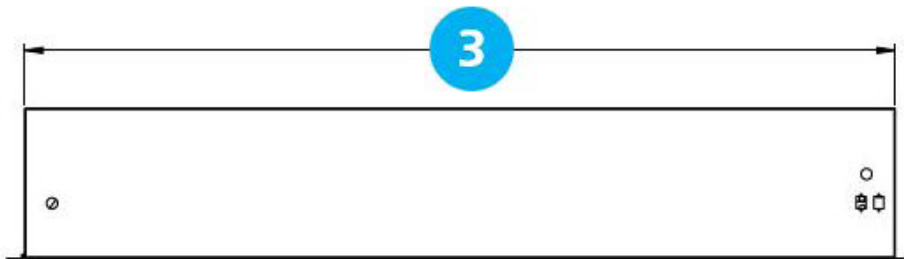

Figure 3.1 GR Front view

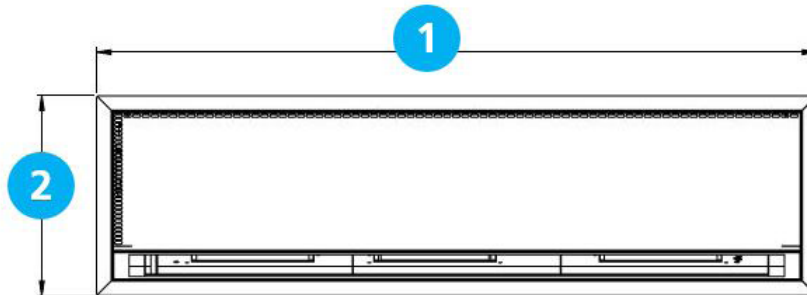

Figure 3.2 GR Bottom view

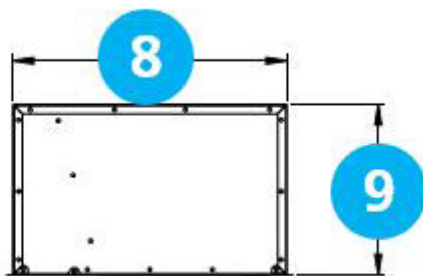

Figure 3.3 GR Side view

Reference	GR 1000	GR 1500	GR 2000
1	1125	1650	2177
2	457		
3	1060	1584	2111
4	70		
5	114	112	114
6	830	1360	1884
7	298		
8	438		
9	273		

Table 3 GR dimensions

Clearance distances

It is recommended that a minimum clearance of 100mm is allowed around the case. The clearance allows for cable entry and prevents combustible surfaces overheating.

The minimum mounting height (floor to grille outlet) is 1.8m. The recommended maximum mounting height is 3m for standard fan setting & 4m for high.

Dimensions. GB Bulkhead mounted models

TD

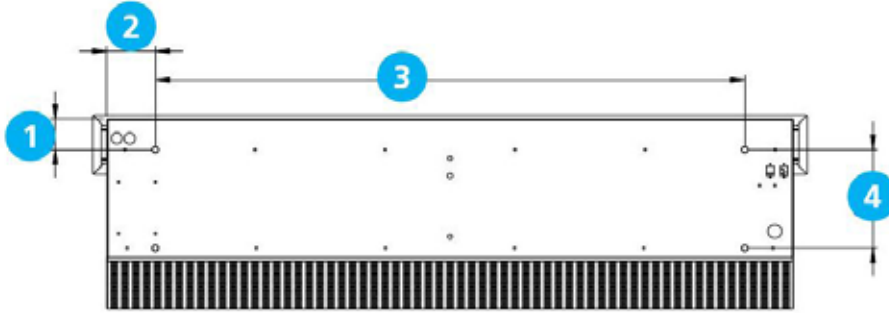

Figure 4 GB Top view

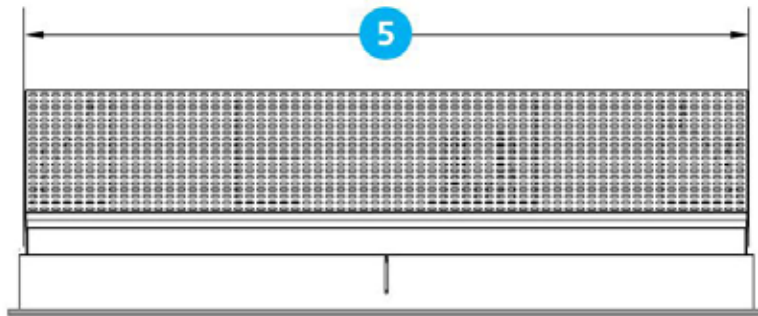

Figure 4.1 GB Front view

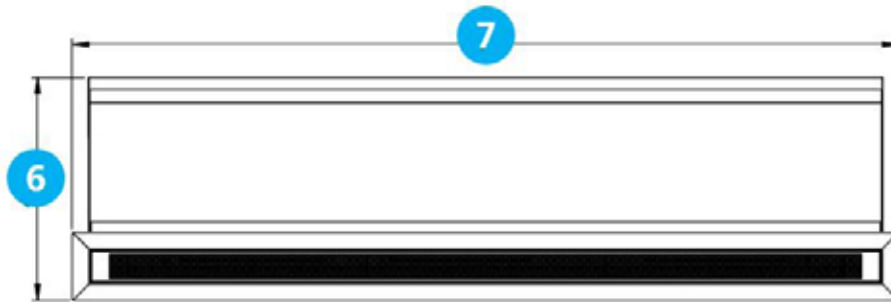

Figure 4.2 GB Bottom view

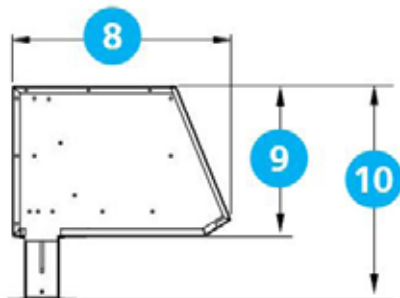

Figure 4.3 GB Side view

Reference	GB 1000	GB 1500	GB 2000
1		70	
2	114	112	114
3	830	1360	1884
4		226	
5	1060	1584	2111
6		448	
7	1125	1650	2177
8		436	
9		300	
10		427-487	

Table 4 GB Dimensions

Clearance distances

It is recommended that a minimum clearance of 100mm is allowed around the case. The clearance allows for cable entry and prevents combustible surfaces overheating.

The minimum mounting height (floor to grille outlet) is 1.8m. The recommended maximum mounting height is 3m for standard fan setting & 4m for high.

Program panel dimensions

The program panel is supplied with an industry standard plastic double surface mounted socket box. Alternatively, the program panel can be flush mounted using a customer supplied metal flush conduit box as shown in Figure 5.2



Figure 5 Surface mount box

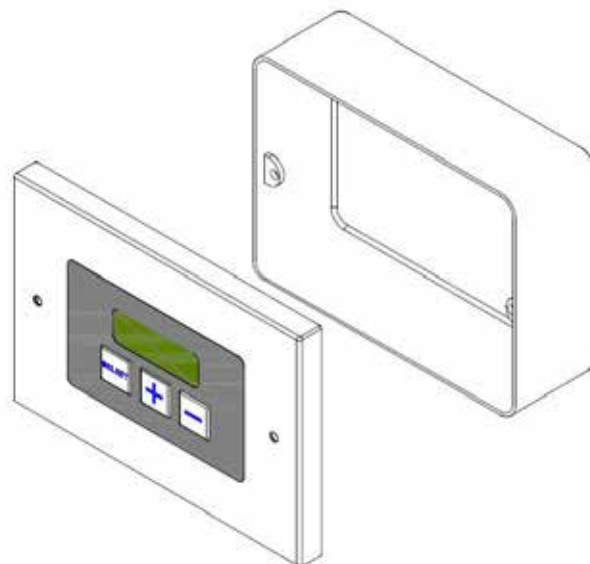

Figure 5.1 Flush mounting using metal conduit box (by others)

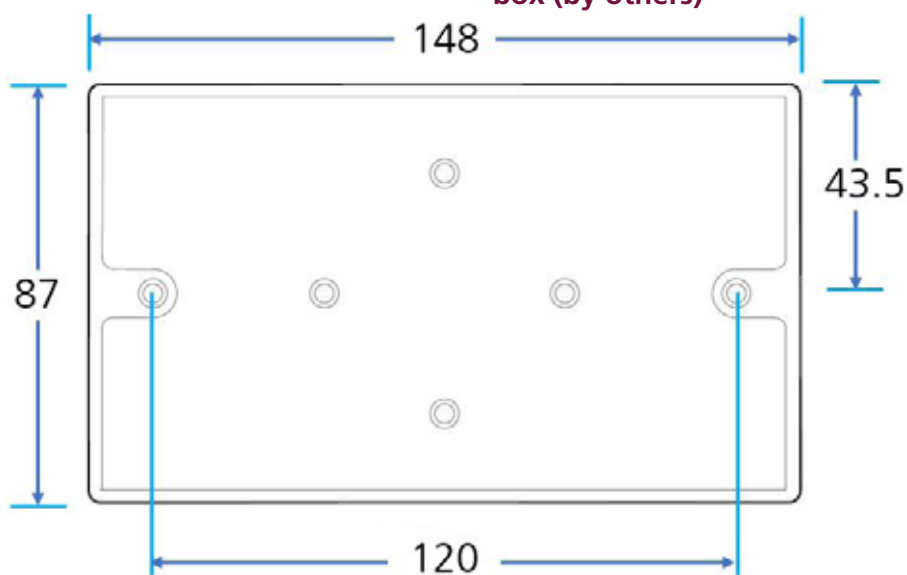

Figure 5.2 Surface mounting back box dimensions

Component layout

TD

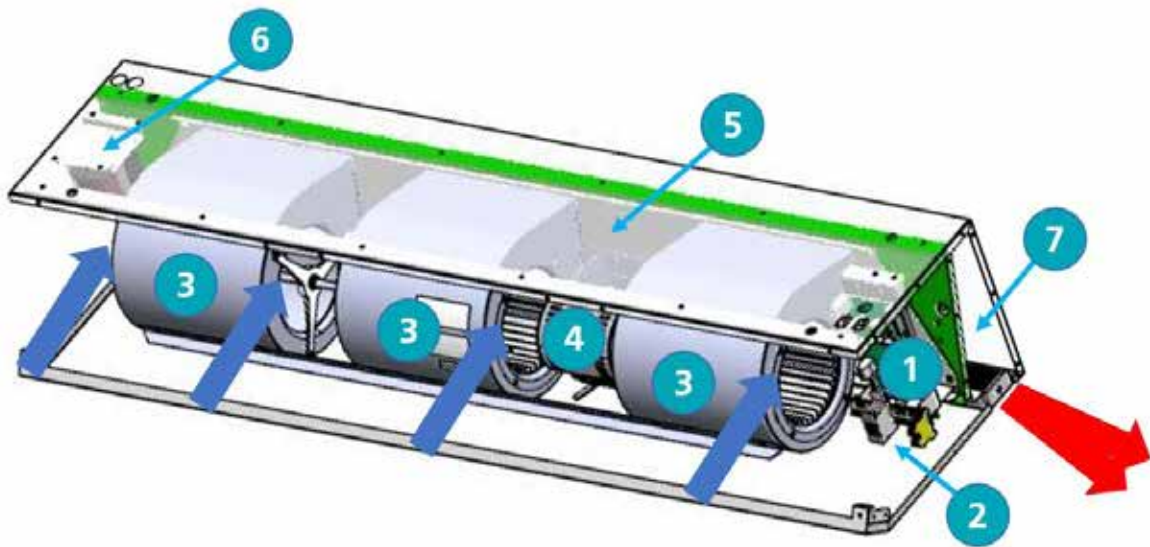

Figure 6 Component layout GS

Location	Component
1	Control panel
2	Installer terminal block
3	Fan
4	Fan motor
5	Fan deck
6	Resistor (1500 only)
7	Heating element

Table 5 GS & GR components

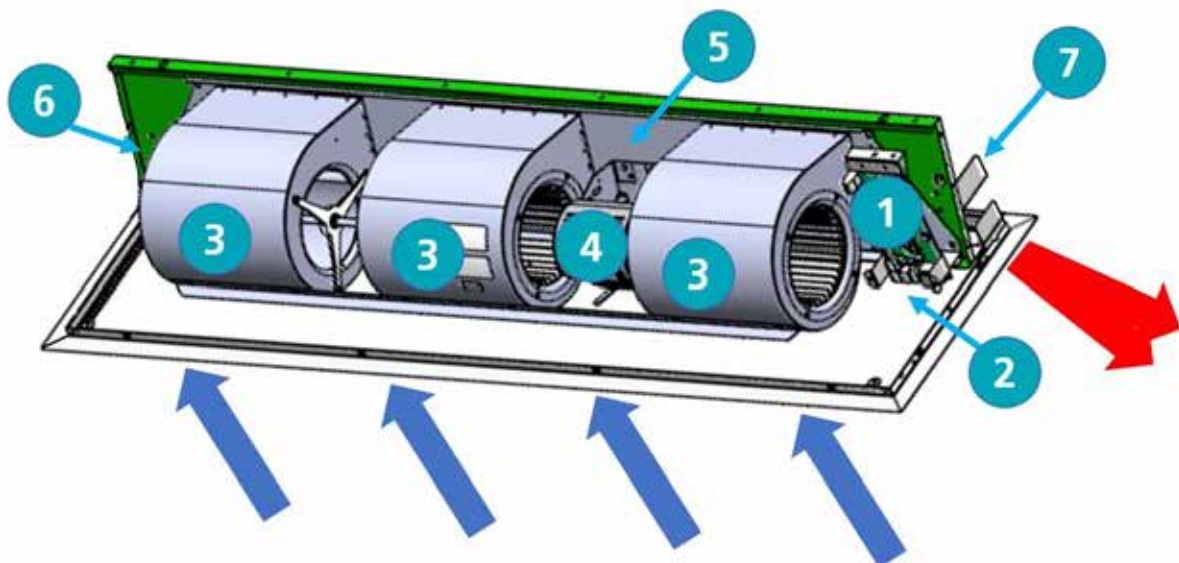

Figure 7 Component layout GR

Installation

Mounting

Guardian GS,GR and GB air curtain units are designed to be installed horizontally directly over the door opening on the inside of the building, against a wall or ceiling.



Care must be taken to allow complete free air movement into the inlet grilles of the unit to ensure the correct working operation of the air curtain. The honeycomb outlet should be as close to the top of the door as possible and can be angled towards the door from 0° to -5°. Ensure to cover the entire door width. See figure 8

Units can be mounted adjacent to each other to cover the full door opening across wider entrances.



The GS units are designed for surface mounting and should not be placed into a ceiling void, due to possible obstruction of airflow and difficulty in routine cleaning and maintenance. Use the GR for these types of applications



It is the sole responsibility of the installer to ensure that the points of attachment to the building are sound.



Verification with the consultant/ architect or owner of the building is recommended to ensure that a sound, stable installation can be achieved.

Electrical supply.

Electrically heated units require a connection to 3 phase 415V power supply only. Ambient and LPHW models require a connection to single phase 230/240V supply only.

Electrically heated models consume 9kW, 12kW, 18kW & 24kW at 415 Volts when switched to the full heat position depending on the model and capacity setting.

The appliance shall be connected to the supply via an appropriate a switched fused isolator, having a contact separation of greater than 3mm. See technical data for fuse rating on page 6

Once the covers have been removed, the installation engineers terminal block is located to the right hand side of the unit. This terminal block is used for the connection of the mains supply and additional controls, for example door switch. Wire in accordance to the appropriate unit diagrams in the wiring section, starting on page 19



For safety reasons, a sound earth connection must always be made to the unit before it is put in to use. The unit should be wired in accordance with IEE Regulations for the Electrical Equipment of Buildings.



The program panel is connected to the control panel (base unit) via a pre-wired RJ45 cable maximum length of 100m. (10m supplied as standard). It is recommended that this cable is run separately within its own trunking to avoid external interference.

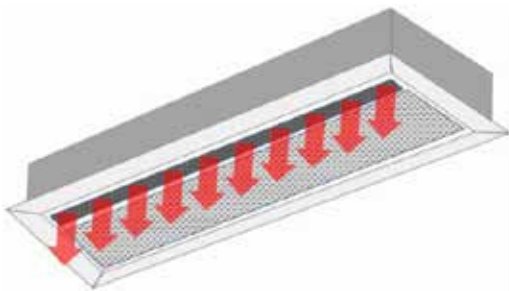

Figure 8 Honeycomb outlet position near to the door adjustable angle of 0 to -5°

Installation process

1. Remove all packaging and covers

Note All outer metal surfaces are covered by a protective plastic film, which must be removed before final fixing and operation of the unit.

2. GS units, Loosen (DO NOT REMOVE) the screws in the top of each front inlet cover [1] (see figure 9.1 and 10 dog bone slot) then slide the left cover to the left [2] which will allow the cover to slide under the end cap. This will allow the next cover to be pushed to the left [3] (see figure 9.1) allowing it to be released from the screw slot [4] by pulling forward and lifted upwards out of the lower groove in the case.
3. The first cover can then be pushed to the right to release it from the screw slot, (see figure 10) then pull forward and lift upwards to be removed. For additional covers fitted on the 1500 or 2000 units loosen the fixing screws and remove as with the previous covers.

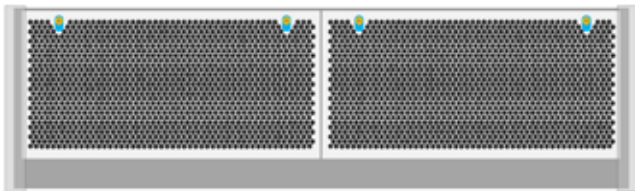

Figure 9 GS cover fixing point

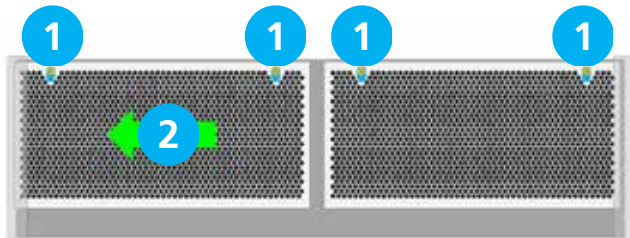

Figure 9.1 GS cover fixing point

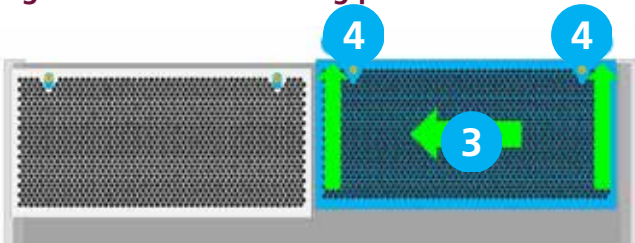

Figure 9.2 GS cover fixing point

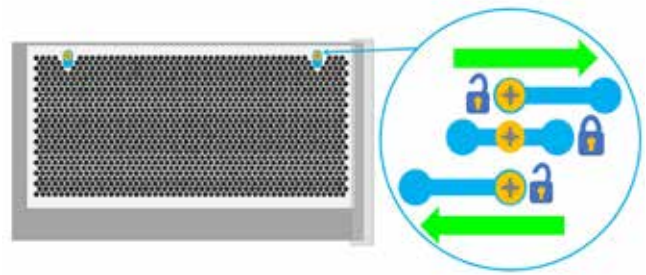

Figure 10 Dog bone screw fixing slot

4. On the GS units the lower cover can be removed by removing the two screws at the top of this cover and then pulled out of the tabs from the main case

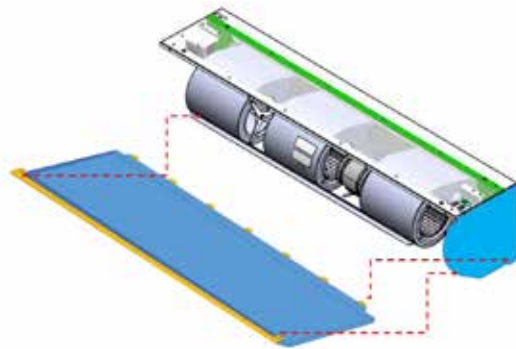

Figure 11 GS lower access panel

1. The GR has two captive screws in each panel, loosen these and hinge the panel down.
2. The panel can be removed completely by releasing the bolt hinges on either side of the panel (see figure 13).



Figure 12 GR cover fixing point

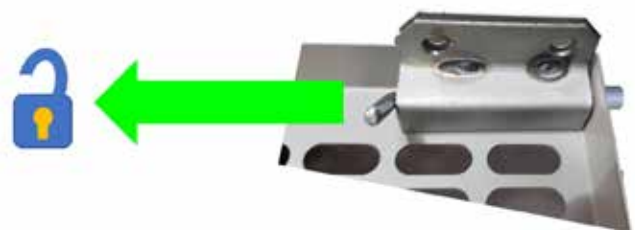

Figure 13 GR bolt hinge

Suspending on threaded rods

1. The product is installed using 4 x M10 threaded rods fitted into the fixing points in the top of casing.
2. The threaded rods must completely pass through the fixing points in the case without being too long to cause damage to products inside the case.
3. Ensure that the secure mounting point in the ceiling is capable of supporting the weight of the unit.
4. Lift the unit (using lifting equipment) onto threaded rods ceiling fixing point.

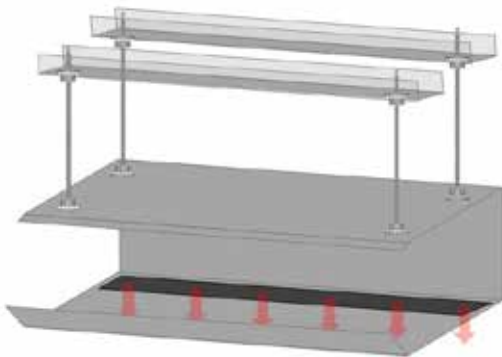

Figure 14 Suspending from threaded rods

5. Level the unit and tighten the fixing points. Carryout a final check to ensure the unit remains level
6. Holes are provided in the casing for cable entry. Choose the appropriate hole to suit the installation. Note the terminal connection block is located to the right of the unit.
7. Install the cable into the case using a suitable cable gland for size of cable
8. Two RJ45 ports are located in the case to connect the program panel and any other air curtains to be controlled
9. Adjust outlet to required angle to give desired performance and tighten outlet grille.
10. Fit the Program panel and commission the unit

Wall mounting bracket



Figure 15 Wall mounting bracket

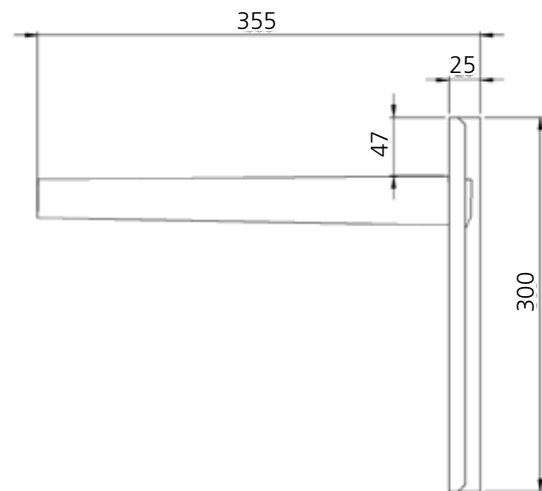

Figure 15.1 Side view

Figure 15.1 shows the overall dimensions of the wall bracket assembly.

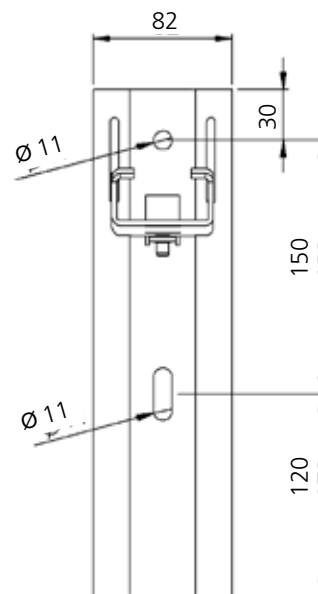

Figure 15.2 Front view

Figure 15.2 shows the dimensions of the bracket that is to be fixed to the wall, along with fixing positions. Please ensure that adequate fixings and wall structure are present to support the unit weight.

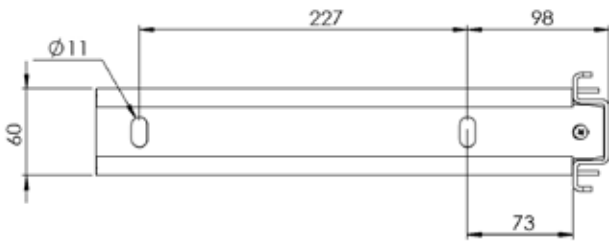

Figure 15.3 Mounting bracket top view

Figure 15.3 shows the dimensions of the bracket section that is to be fixed to the unit using 4 x M10 x 30mm 8.8 set screws, 4 x shake prove washers and 4 x flat washers. Use the four fixing points supplied in the casing

1. Using the details supplied with the bracket position the bracket against the wall at the desired mounting height and mark through the holes
2. Drill the wall then fix the brackets in position. Lift the chassis (using lifting gear if necessary) onto drop rods in the bracket
3. Ensure the unit is level and then tighten the fixing points with a final check to ensure the unit is level
4. Follow the instructions 6 to 10 of the drop rod mounting instructions grille.

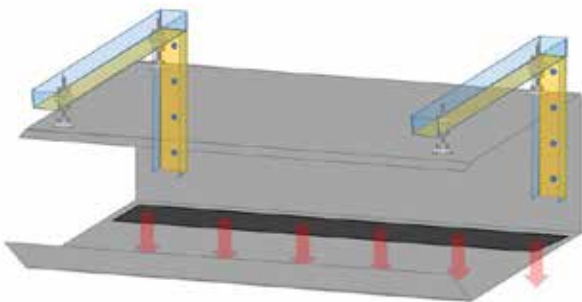

Figure 16 Mounting bracket option

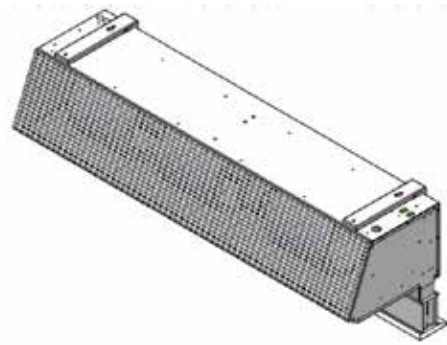

Figure 16.1 Mounting bracket fitted to GB unit

Installation details - LPHW Only

Installation of the LPHW unit is as described earlier. Once situated, access to the heating coil and controller base unit is via removal of the case front.

The LPHW copper tubing connections are 22mm outside diameter. Ensure correct water seal fittings are used. It is recommend to use a suitable water mains isolation valve to ease any maintenance.

The unit is handed for right hand pipe connection.

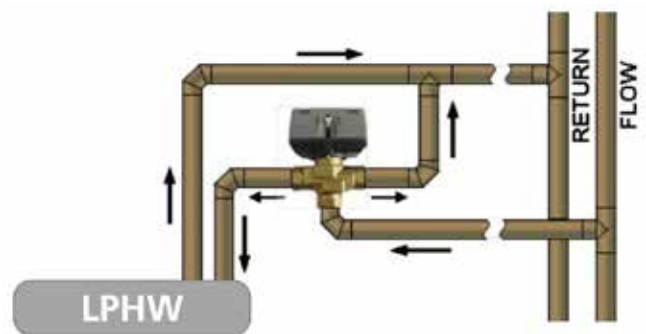

Figure 17 Typical schematic of a 3-port valve system.

Program panel

The program panel can be installed using the standard double surface box supplied with the program panel or recessed using a suitable flush mounted double conduit box. see "Figure 5.2 Surface mounting back box dimensions" on page 11 for details



Figure 18 Program panel

The program panel can be connected up to a maximum of 16 air curtains in one network.

For mains wiring refer to the wiring diagram relating to the model being used see "Wiring diagrams." on pages 19 to 21

The program panel is connected to the base unit in the air curtain via pre-wired RJ45 cable/plugs. These cables are available in 2, 10, 20, 30, 50 and 100m lengths. It is recommended that this control cable is run separately within its own trunking to avoid external interference.



Maximum cable run in any network must not exceed 100m in total including program panel cable.

Note: All air curtains connected within the network system will operate under the settings of the single program panel.

Any air curtain within the network can be connected with and respond to the following optional circuits:

- External switch (ie BMS enable) where required, to be volt free and wired in PARALLEL via normally open contacts to each terminal pair 'TIMER'. (Contacts closed to enable). Only air curtain(s) wired this way will respond to the enable signal.

- Door switches where required, to be volt free and wired to INDIVIDUAL base units via normally closed contacts to each terminal pair 'DOOR'. (Contacts open to enable door mode). Only air curtain(s) wired this way will respond to the door mode.
- An external sensor, where required, can be wired to INDIVIDUAL base units to each terminal pair 'EXT'. Only air curtain(s) wired this way will respond to the sensor setting.

Standard and high capacity fan and heat settings

All units are supplied as standard capacity
All units have fans capable of providing standard & high capacity air duties (speeds Medium and High) which are controlled via the program panel supplied with every unit.

Electrically heated units provide standard & high capacity heating outputs.
These settings can be quickly changed from standard to high capacity on site by the installation engineer.

Fan speed setting

On the Program panel during normal operation mode the display is dimmed.
Pressing the **SELECT** button, will put the panel into active mode. If no button is pressed for several seconds the display reverts to normal mode.
Once the display becomes illuminated press the **SELECT** button once.

Display shows the fan speed. (default is F0)

Press **+** to increase fan speed.

Press **-** to decrease fan speed.

Three speeds and an 'off' setting are available:

0 F1 = Speed 1 (Low)

0 F2 = Speed 2 (Medium-Standard)

0 F3 = Speed 3 (High)

0 F0 = Fan off



Ensure the supply cables are adequate for the higher loading with the high capacity settings of the fans. See technical data on page 6

Ambient and LPHW model

The Ambient models have no heat elements, and the LPHW models has a coil which the capacity cannot be controlled by the internal circuit board, therefore only the fan capacity can be changed to suit site requirements.

This is achieved by altering the fan speed setting in the program display.

Note: The LPHW heat output can be controlled via a 3rd party thermostat and valve connected to the heat network control system.

Electrically heated model

On the electrically heated models the fan capacity can be adjusted in the same as the ambient by setting the fan speed to F1, F2 or F3

The heat capacity can be changed by fitting the jumpers E1, E2 and E3 in to the installers terminal block 1a to 6a see wiring diagram on page 20

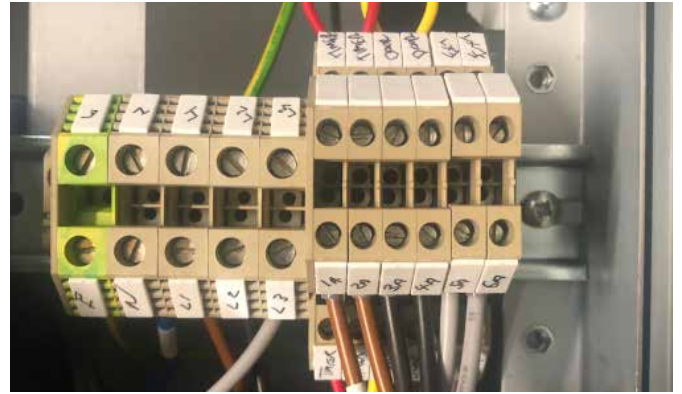

Figure 19 Heat capacity jumpers factory setting (no jumpers fitted)

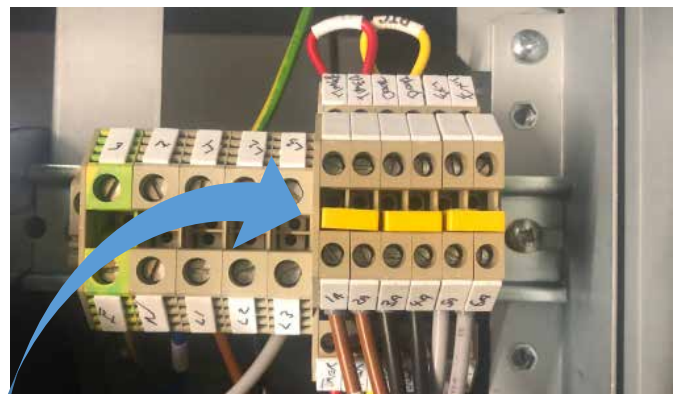

Figure 19.1 Heat capacity jumpers HIGH capacity (jumpers fitted)



Figure 19.2 Heat capacity jumper pack part number 1026901

Wiring diagrams.

NOTE External switch inputs (e.g. Timer) to be volt free and wired via normally open contacts to terminal pair marked e.g. 'timer' (contacts closed to enable). Remove relevant factory fitted jumper for any optional input.

Installer wiring - Ambient models, single phase

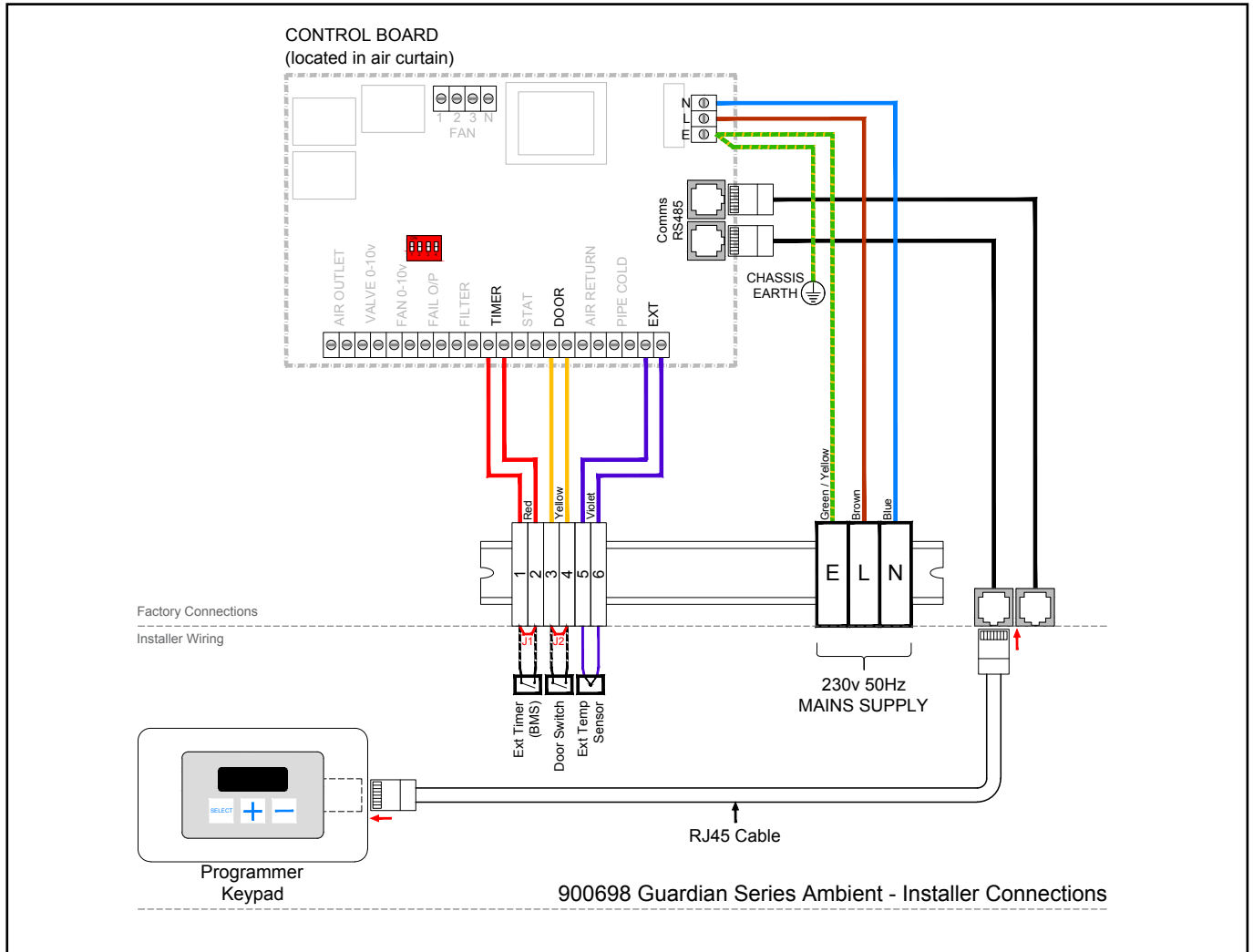

Figure 20 Wiring diagram ambient

Terminal	Description	Cable
N	Neutral	1.5mm ²
L1	Phase 1 (or 1 Phase supply)	
E	Mains earth	
Timer BMS (J1)	Optional external switch	
Door (J2)	Optional door contact	
Ext	Optional external sensor	
PCB Fuses	Rating (A)	
F1	T1H (slow blow)	

Table 6 Cable specification ambient

Protection

External circuit breaker with the appropriate rating should be installed for the protection of the installation.

Installer wiring - Electric heated models, three phase only

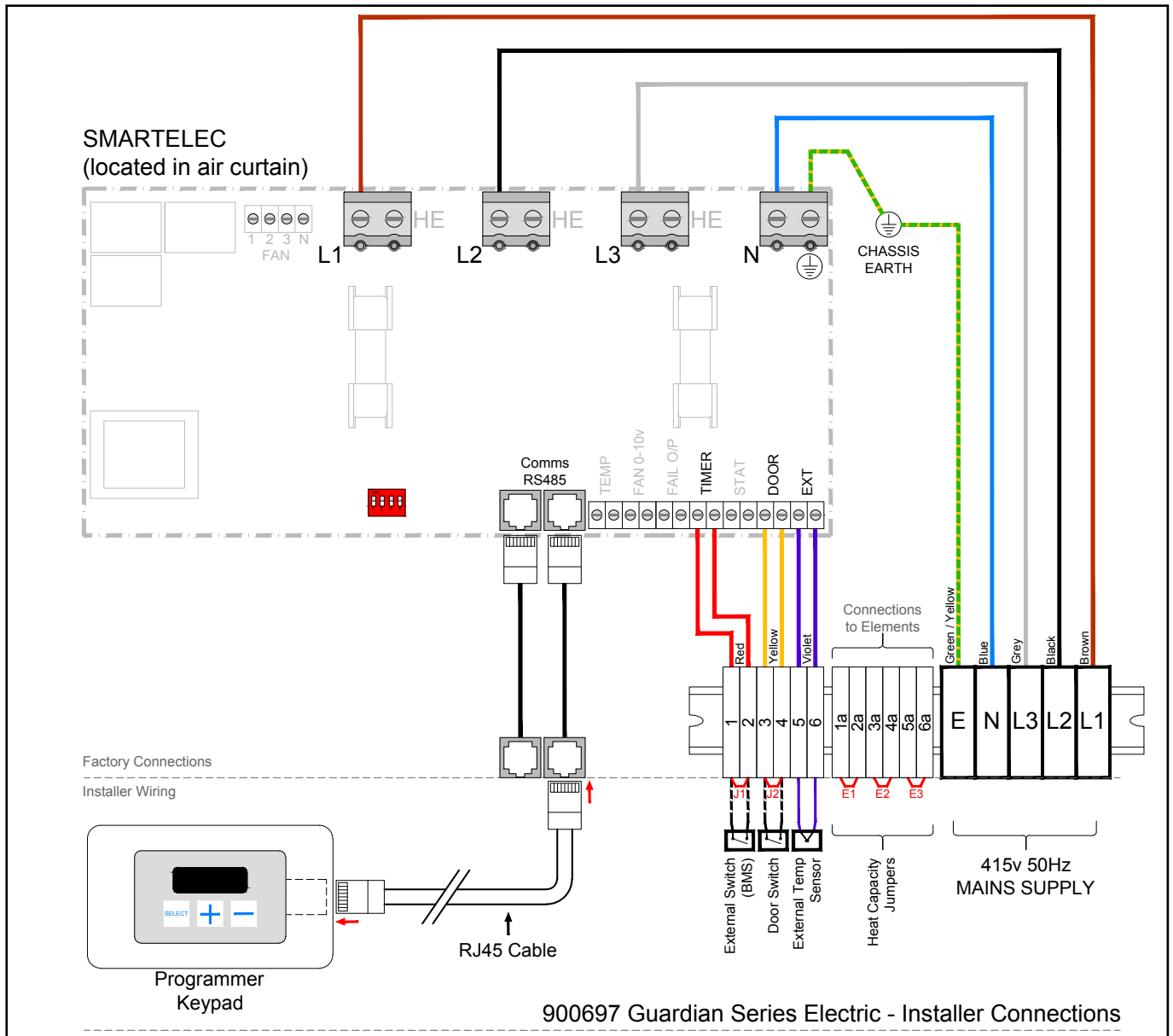

Figure 21 Wiring diagram electric heated

Terminal	Description	Cable
E	Mains earth	10mm ²
N	Neutral	
L1	Phase 1	
L2	Phase 2	
L3	Phase 3	
1a to 6a	Capacity jumpers see page 18	

Table 7 Cable specification electric heated

Protection

There are two high speed fuses on the base unit to protect the switching thyristors for the heater. An external circuit breaker with the appropriate rating should be installed for the protection of the installation

Terminal	Description	Cable
Timer/BMS (J1)	Optional external switch	1.5mm ²
Door (J2)	Optional door contact	
Ext	Optional external sensor	
Fail o/p	Fault output (0-5v)	
Fan	Optional 0-10v fan output	
Thermostat	Internal high limit thermostat	
PCB Fuses	Rating (A)	
F1	T1H (slow blow)	
F2 & F3	400v	

Table 7.1 Cable specification electric heated continued

Installer wiring LPHW heated models, single phase

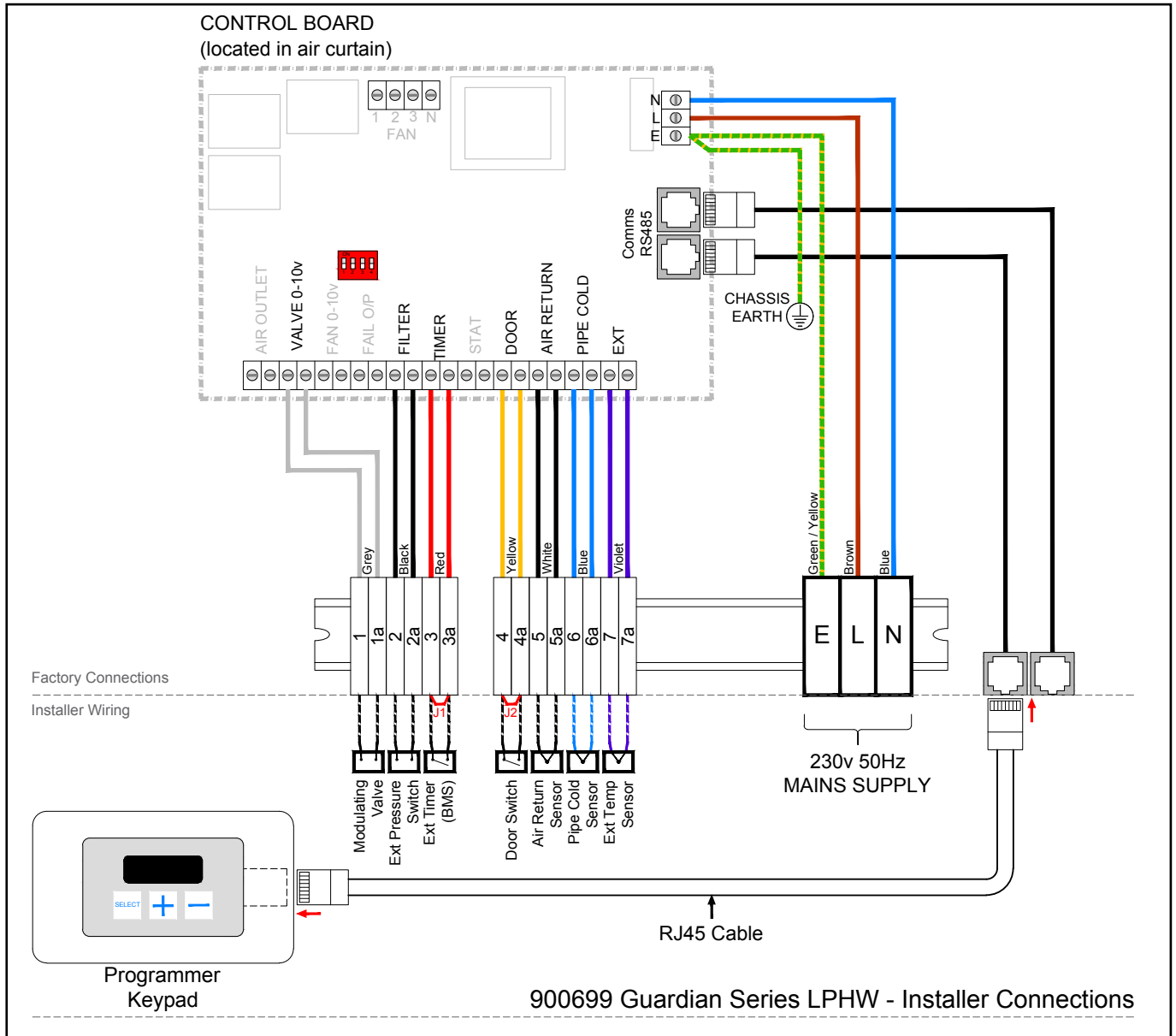

Figure 22 Wiring diagram LPHW heated

Terminal	Description	Cable
N	Neutral	1.5mm ²
L1	Live	
E	Earth	

Table 8 Cable specification LPHW heated

Protection

External circuit breaker with the appropriate rating should be installed for the protection of the installation.

Terminal	Description	Cable
Timer/BMS (J1)	Optional external switch	1.5mm ² maximum
Door (J2)	Optional door contact	
Ext	Optional external sensor	
Air return	Optional sensor	
Pipe cold	Optional sensor	
Fail o/p	Fault output (0-5v)	
Fan	Optional 0-10v fan output	
Valve	Optional 0-10v valve output	
Filter block	Optional filter blocked switch	
PCB fuses	Rating (A)	
F1	T1H (slow blow)	

Table 8.1 Cable specification LPHW heated

Optional wiring

At the Installers terminal block, remove the required jumper(s) and then wire in any external connections that are required.

External switch (i.e. BMS enable) to be volt free and wired via normally open contacts to terminal pair 'TIMER'. (Contacts closed to enable). Remove factory fitted jumper J1.

- Door switch to be volt free and wired via normally closed contacts to terminal pair 'DOOR'. (Contacts open to enable door mode). Remove factory fitted jumper J2.
- See adjustments and settings on page 25 for the program panel - Door link settings. Which provides an alternative fan speed and heat setting that is activated only when the door link is open circuit.
- An external sensor, where required, to be wired to INDIVIDUAL base units to each terminal pair 'EXT'. Only air curtain(s) wired this way will respond to the sensor setting.
- Refer to page 25 for the program panel- External temperature. if the factory supplied optional external temperature sensor is connected to the air curtain. If the external temperature is equal to the set temperature, all air curtains are turned off. The temperature must then drop to 3°C below the set temperature before the air curtains are turned back on.
- Protection. There are two high speed fuses on the electric model base unit to protect the switching thyristors for the heater. An external circuit breaker with the appropriate rating should be installed for the protection of the installation. See technical data for the correct MCB

CONTROLLER

Networking

The program panel is connected to the first air curtain via pre-wired RJ45 cable to the socket in the first air curtain housing. See figure 25 on page 23

Connect a second RJ45 cable in to the spare RJ45 socket of the first air curtain, and then take across to one of the RJ45 sockets in the second air curtain.

Further RJ45 cables can be used to connect more air curtains to the network, up to a maximum of 16 air

curtains can be linked to one program panel.

The RJ45 cable is 10m as standard however it is available in 2m, 20m, 30m, 50m and 100m lengths.



Maximum length 100m. (Total length of cable used between program panel and last air curtain in network).

It is recommended that this control cable is run separately within its own trunking if possible, to avoid external interference.

Note: All air curtains connected within the network system can be controlled under the user settings of the single program panel.

Air curtain addressing

All air curtains work on an address to communicate with the program panel and are supplied with a default address of '0'.

Where multiple air curtains exist in a network they must be re-addressed using a unique address (0-9/A-F). This is achieved using the 4 way DIP switch [2] mounted on the control panel base unit PCB



Figure 23 DIP switch position

The program panel will check all addresses on first power up and this is displayed as the first digit on the display (in a network set up, all addressees will be viewed in rotation).

Note: If any address is altered after initial power up or an air curtain removed after initial installation, the program panel will also retain the original address although unable to respond. To remove an unwanted address follow the details in Power-up manual reset.

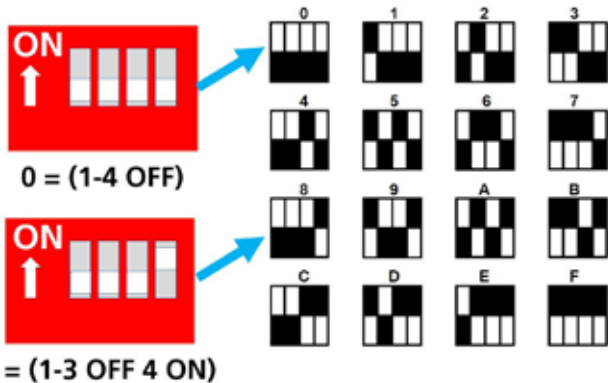

Figure 24 Air curtain address numbers.

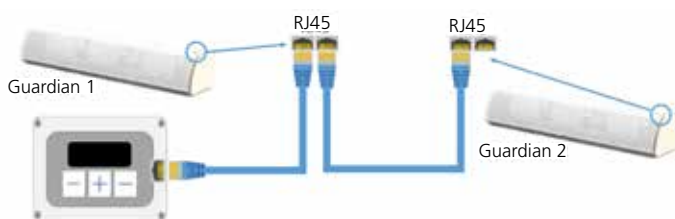

Figure 25 Wiring of 2 or more networked air curtains.

Power-up manual reset

The system can be reset by powering-up the panel whilst holding down the **SELECT** and **-** buttons.

The display shows the 'start' pattern but then goes blank.

Release the buttons where upon the display resumes and the system addressing commences, finding only those air curtains which are actually connected and working.

If **E ng** appears on the display, press and hold the **+** button for a few seconds then release. The display will then return to the normal mode

User Instructions

Keypad buttons



The buttons have the following functions:-

- SELECT** Press the select button to allow navigation.
- +** Press the + button to increase a setting.
- Press the - button to increase a setting.

Keypad display.

Operation - Ambient & LPHW Models Only

On first power up, the display will show and have the following default settings:



- F. 0 (no fan)
- H. 0 (no heat)
- 16 (°C. Heat set point)

If no Air Curtains are detected the display will show:



Note: Subsequent power ups will retain any entered settings in the display internal memory.

In normal operation the display will show for example:



'1' denotes the Air Curtain ADDRESS, and '27' the current outlet temperature.

If the display is delivering power it will then show



If an external temperature sensor is fitted, then the display will also show



Standard settings

Press the **SELECT** button. This will cause the display to brighten and display Air Curtain number and it's set point temperature.



Pressing the **SELECT** button again will show the fan setting eg.



Pressing the **SELECT** button again will display the heat setting eg.



Engineers settings

To turn on the engineers settings press and hold the **+** button until the display goes blank then press the **SELECT** button. The display unit will now display 'Eng' briefly.



This will disappear after a period of 10 minutes of inactivity on the keypad.

On pressing the **SELECT** button again, the display unit now works in the same way as standard for the fan and heat settings. The next press of **SELECT** will advance to the 'door link' settings if only one air curtain is connected, or 'link group interlocks' if more than one air curtain is connected.

Door link settings

Two settings are available for use when the door link circuit terminals are open circuit (PCB link removed). The first of these is displayed as:

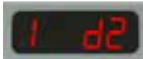

'1' is the Air Curtain address and 'd2' denotes fan speed 2.

Press the **+** or **-** buttons to increase/decrease the desired setting between d0, 1, 2, or 3.

The second is displayed as:



'1' is the address for the Air Curtain and 't1' denotes heat setting 1. Press the **+** or **-** buttons to increase/decrease the desired setting between t0, 1, 2 or 3. where 0 is heat off.

1 = 5°C

2 = 10°C

3 = 15°C

Pressing the **SELECT** button again advances to the link group interlock settings.

Link-group interlock

If more than one Air Curtain is connected to the display, then there are two sets of interlocks available to enable a

single Air Curtain in a group to be the 'master' controller based on links used.



'1' is the Air Curtain address and 'C0' is the default setting (no interlock set). Press the **+** or **-** buttons to increase/decrease the desired setting between C0, or 1-7 (see Table below). If the Air Curtain is set to eg.



This denotes that Air Curtain '1' is set to be the master for door and BMS interlocks. If interrogated all other Air Curtains will then display eg.



This denotes a unit that is not the master.

To set more than one interlock, add the appropriate numbers together, eg. 'C3' above works on timer and door interlocks.



If a controller is not the master, all three interlock links must be in place.

All controllers

"C" interlocks setting	Effect
1	Timer/BMS interlock
2	Door interlock
4	Thermostat interlock
"L interlocks setting	Effect
1	Not used
2	Not used
4	Block filter interlock

This setting can be accessed from the engineers settings whilst the external temperature indication is showing. This is displayed as:



This allows a single group of settings to be copied to all controllers in a network. Individual settings can still be used at a later date if required.

External temperature

Display will show eg:



This will only be displayed if there is an external sensor fitted, and shows the external sensor temperature set point. Once set the Air Curtain will turn off when it reaches the set point. The temperature then has to drop 3°C before the Air Curtain turns back on again.

External temperature offset

Display will show eg:



If the outside temperature falls to 0°C, this setting shows the temperature offset above zero. This will temporarily raise the temperature setting 6°C above the actual set point. Possible settings are 0-9 where 0 is off, if this function is not required.

Temperature limits

The next two displays eg:



These show the permissible upper and lower limits for setting the external temperature sensor set point. This is useful for allowing the end user limited control over this setting. The maximum (default 35°C) may be set anywhere between the current minimum and 50°C, and the minimum (default 16°C) may be set anywhere between 3°C and the current maximum.

Air return and pipe cold sensors

The readings from these sensors is not shown on the display, and unless both are connected there is no effect on the heating control. When both sensors are connected they operate as follows:

When the heating is first turned on the temperature readings from the sensors should be close together, two minutes later there should be a difference of at least 2°C. If there is no difference then the controller assumes that there is no flow, then turns the heating off.

Operation - Electric Heat Models Only

Keypad display.

Display	Meaning
- -	First power up
E rr	No air curtains found
0 25	Curtain address and temperature set point

Normal operation

During normal operation mode the display is dimmed.

Pressing the **SELECT** button, will put the panel into active mode. If no button is pressed for several seconds the display reverts to normal mode.

During normal operation the unit will display for example:



Where '0' is the curtain address, and '25' the temperature measured for the unit.

Where multiple air curtains exist in a network, the display scrolls through each unit in turn, changing approximately once every second.



If the air curtain is in operation and under heat demand, a 'decimal point' is shown after the air curtain address.

OFF mode

During normal operation, press and hold the **-** button for approximately two seconds. The display blanks until you release the button. The heating and fans are now turned off. Releasing the button in less than this time and the action has no effect.

Where multiple air curtains exist in a network, this action turns off all air curtains.

Settings mode

Active settings display

To enter the Settings mode press the **SELECT** button. This will illuminate the screen. Press the **SELECT** button till the desired setting is shown.

By pressing the **SELECT** button it will also advance to the next setting.

Note: If a setting has been altered by using the **+** or **-** buttons, it must be confirmed by pressing the **SELECT** button.



Settings display

Press the **SELECT** button to advance through the settings.

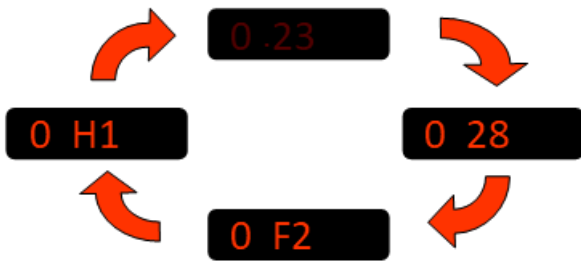

Where multiple air curtains exist in a network and controlled from a single keypad, these will be detected and displayed in turn, for example:



Any air curtain in the network can be accessed by pressing the **SELECT** button when its address appears on the display. The settings can then be accessed as previously described.

Setup configurations

Set fan speed

Once the display becomes illuminated press the **SELECT** button once. Display shows the fan speed.

Press **+** to increase fan speed.

Press **-** to decrease fan speed.

Three speeds and an 'off' setting are available:

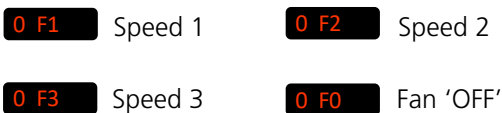

Set heat

Press the **SELECT** button again Display shows the heat setting.

Press **+** to set heat 'on'.

Press **-** to set heat 'off'.

If no button pressed for 2 seconds, display will revert to normal user. eg **0 25**

Set temperature

Press the **SELECT** button once to allow changes to be made.

Press **+** to increase temperature set point. Max 35°C

Press **-** to decrease temperature set point. Min 16°C

Display shows for example: **0 22**

Networked air curtains

Where multiple air curtains exist in a network and controlled from a single keypad, these will be detected and displayed in turn, for example:

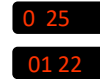

Any air curtain in the network can be accessed by pressing **SELECT** when its address appears on the display. The settings can then be changed as previously described.

Engineers settings

Other options are available in engineer's mode.

To access the engineers mode either: press and hold the **+** button for a few seconds until the display goes blank, then press **SELECT** briefly.

The display will show **E ng**

or

Power-up the system with the **SELECT** and **+** buttons pressed and release when the display goes blank **E ng** display will show

As in normal mode, Engineers set-up mode is started by pressing the **SELECT** button whereupon the display will illuminate. Advance through the normal modes, settings of temperature, fan and heat by pressing the **SELECT** button.

Pressing the **SELECT** button again advances to further options to allow other settings of the system. The engineers set-up options listed herewith depend upon various factors e.g. optional door switch, multiple air curtains etc.

Note: If a panel has never before been run, it automatically starts in engineer's mode when first powered-up.

Engineer's mode automatically self-clears after approximately 10 minutes of non-activity on the switches.

Door link settings

This provides an alternative fan speed and heat setting which is activated only when the door link is open circuit.

The fan speed is accessed by pressing the **SELECT** button until the display shows: **0 d0** Use the **+** and **-** buttons to change the setting.

Display	Meaning
0 d0	Fan off
0 d1	Fan speed 1
0 d2	Fan speed 2
0 d3	Fan speed 3

The temperature setting when the door link is open circuit, is accessed by pressing the **SELECT** button until the display shows 0 t0

Use the + and - buttons to alter the temperature value.

Display	Meaning
0 t0	Heat off
0 t1	5°C
0 t2	10°C
0 t3	15°C
0 t4	20°C
0 t5	25°C
0 t6	30°C
0 t7	35°C

Link-group interlock

If there is more than one air curtain, a group interlock option may be set. This provides an alternative fan speed and heat setting when activated by certain external connections on individual air curtains.

This function is accessed by pressing the **SELECT** button until the display shows 0 C0 (where '0' is the air curtain address to be used as a master unit for interlocks.) See table below for possible settings

Display	Meaning
0 C0	Default setting
0 C1 to 0 C7	Master setting range
1 C-	Other air curtains

All air curtains

Master setting	Function
1	Timer/BMS interlock
2	Door interlock
3	Timer/BMS/door interlock
4	Stat interlock
5	Timer/BMS/stat interlock
6	Stat/door interlock
7	Timer/BMS/stat/door interlock

This function is accessed by pressing the **SELECT** button until the display shows ≡ 25. Using this setting all air curtains in a network respond to the same settings. Settings for individual air curtains can still be changed if required.

External temperature

This is only displayed if the factory supplied, optional external temperature sensor is connected to the air curtain.

This function is accessed by pressing the **SELECT** button until the display shows 0 25. Use the + and - buttons to change the desired temperature setting.

If the external temperature is equal to the set temperature, all air curtains are turned off. The temperature must then drop to 3°C below the set temperature before the air curtains are turned back on.

Note: For multiple air curtains - more than one can have an external sensor connected. When this is the case the sensor values are displayed as an average. (If one external sensor goes faulty, the average is worked out from the remaining working ones).

External temperature offset

This function is accessed by pressing the **SELECT** button until the display shows **004**

This setting allows the temperature setpoint to be automatically increased as the external temperature falls to, or below, zero. For instance, a setting of 4 means a +4°C offset at 0°C. The maximum offset is 9°C. If this feature is not required the setting should be **000**

Note: When more than one air curtain is used, this feature will only work under the 'all controllers' setting.

C

Example with offset at 9

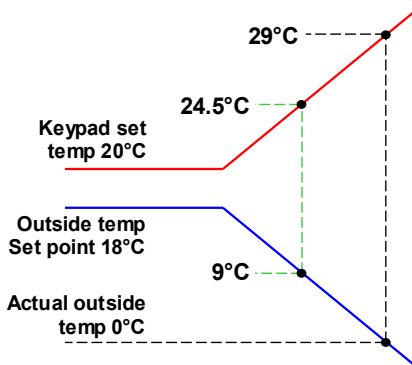

Temperature limits

This function is accessed by pressing the **SELECT** button until the display shows **35** and **16** respectively i.e. maximum and minimum set limits for set temperature.

Use the **+** and **-** buttons to change to the desired limit temperature settings.

The maximum (default 35°C) may be set anywhere between the current minimum and 50°C, and the minimum, (default 16°C) may be set anywhere between 3°C and the current maximum.

To exit the engineers mode press and hold the **SELECT** button for a few seconds.

Keypad sequences

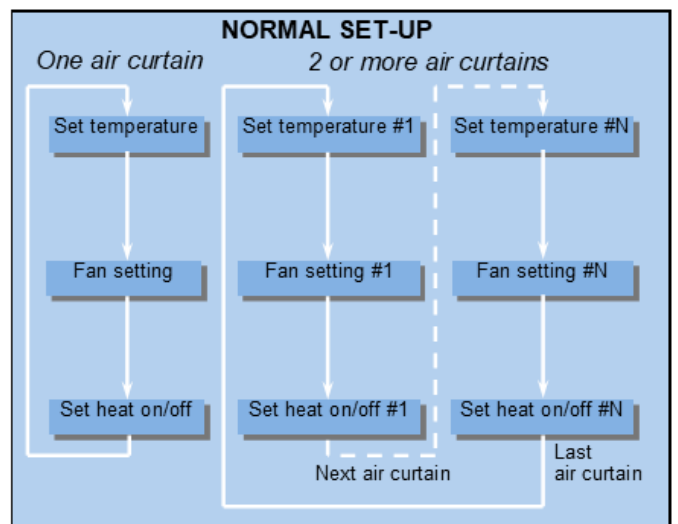
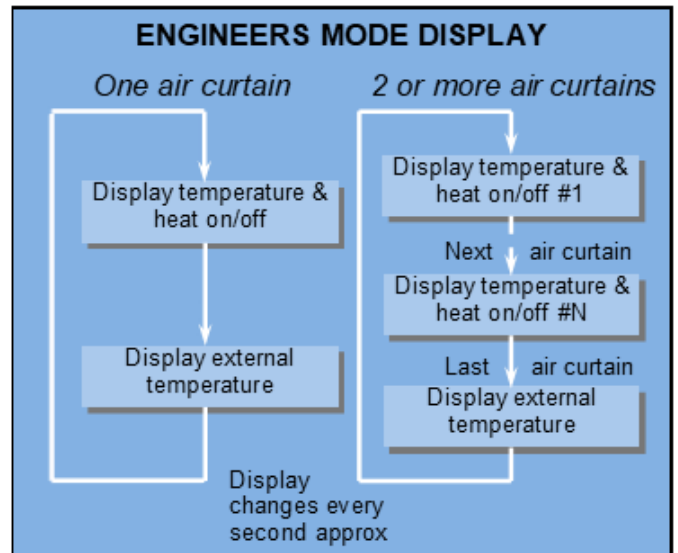
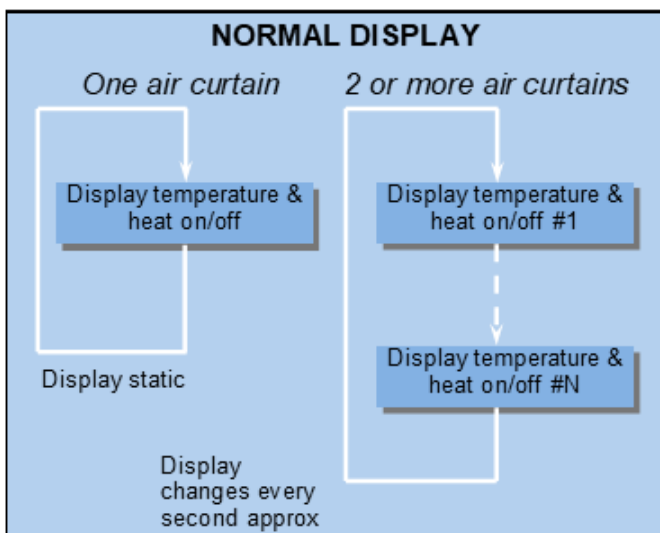

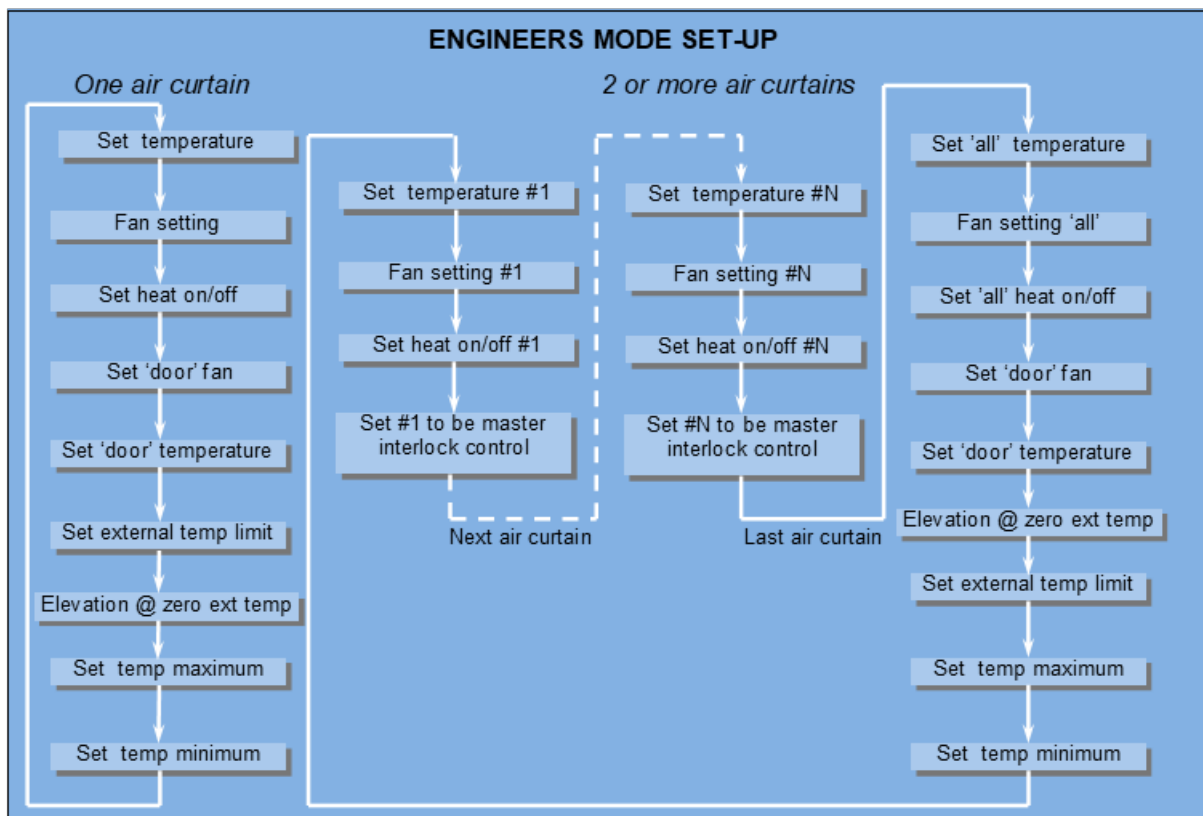

MODBUS Protocol

The modbus hardware is configured as follows:

- RS485 serial half-duplex interface
- 9600 baud
- 8 bits
- even parity / no parity (see below)
- 1 start bit
- 1 stop bit
- RTU mode

This means the same software will run in a standard panel driven display and also in modbus mode, but in a modbus installation only 8 maximum controllers may be supported.

Modbus address – the unit will respond to its own coded address as set by the bitswitches as follows: It will also respond to 'broadcast' mode 0.

Even parity settings (Bitswitch3 OFF)		No parity settings (Bitswitch3 ON)	
Modbus Address	Switch Setting	Modbus Address	Switch Setting
16	0	24	8
17	1	25	9
18	2	26	A
19	3	27	B
20	4	28	C
21	5	29	D
22	6	30	E
23	7	31	F

Modbus function codes supported

Codes	Descriptions	Range of arguments
01, 02	Read coils, read discrete inputs (equivalent)	Coils 1 to 24
03, 04	Read Holding registers, input registers (equivalent)	Registers 121 to 126
05	Write single coil	Coils 13 to 24
06	Write single register	Registers 125, 126

All other MODBUS function codes will generate exception code 01, function not recognised.

Function arguments — Registers			
0	Controller type	Read only	(undefined)
121	Heatsink	Read only	
122	System control temperature	Read only	
123	Outside air temperature	Read only	
124	Power ratio	Read only	
125	Set point temperature	Read/write	
126	Set point temperature on door down	Read/write	(always to nearest 5°C)
127	Hours run	Read only	(16 bit result)

Function arguments — Coils

Arguments which are outside the ranges for registers and coils in the lists below will cause exception code 02 error address out of range

1	Fan1	Read only	Set if fan 1 actually running
2	Fan2	Read only	Set if fan 2 actually running
3	Fan3	Read only	Set if fan 3 actually running
4	Timer_link	Read only	Set if timer link open circuit
5	Phase rotation	Read only	Arbitrary indication of phase
6	Stat_link	Read only	Set if thermostat link open circuit
7	Door_link	Read only	Set if door link open circuit
8	Status_heat	Read only	Set if heating elements on
9	Status_temp	Read only	Set if system temperature measurement fail
10	Status_hs	Read only	Set if heatsink temperature measurement fail
11	Status_ext	Read only	Set if external temperature measurement fail
12	Ext_exists	Read only	Set if external thermistor not fitted
13	Set_fan1	Read/write	Switch fan 1
14	Set_fan 2	Read/write	Switch fan 2
15	Set_fan 2	Read/write	Switch fan 2
16	Heat	Read/write	Switch heat demand on/off A
17	Timer_link_mask	Read/write	Set to force timer link open circuit operation
18	0	Read/write	May indicate fault condition if read returns '1'
19	Stat_link_mask	Read/write	Set to force thermostat link open circuit operation
20	Door_link_mask	Read/write	Set to force door link open circuit operation
21	Set_doorfan 1	Read/write	Switch fan 1 when door link open circuit
22	Set_doorfan 2	Read/write	Switch fan 2 when door link open circuit
23	Set_doorfan 3	Read/write	Switch fan 3 when door link open circuit
24	0		System reset (*)

(*) A read or write to this coil causes the addressed controller to execute a restart as if being powered up.

There is no response and the unit will not respond to further commands until approximately 1 second has elapsed.

Arguments which are outside the ranges for registers and coils in the lists above will cause exception code 02 error - address out of range.

C

Maintenance and servicing



Always ensure that the main external electricity supply is switched off and lock the switch (if fitted) before commencing any maintenance on this heater



To obtain the best results from the heater, it is essential to avoid the accumulation of dust and dirt within the unit on the air inlet and discharge grilles. For this reason, regular cleaning is necessary, paying particular attention to the removal of dirt build up on the fan assembly.

Cleaning of the fan is best carried out with a soft brush and vacuum cleaner

The product should be serviced annually, by a competent person.

- 1. GS units.** Loosen the two screws securing the inlet cover and slide towards the end cover, now loosen the two screws in the next panel and slide towards the first panel which will then allow this panel to be released and lifted out of the dog bone slot This panel can then be lifted out of the tabs at the bottom to fully release. see figure 9 on page 14
- 2. GR units** loosen the screws securing the inlet grille and hinge down, the grille can be removed by releasing the spring loaded bolt to either side. See figure 12 and 13 on page 14

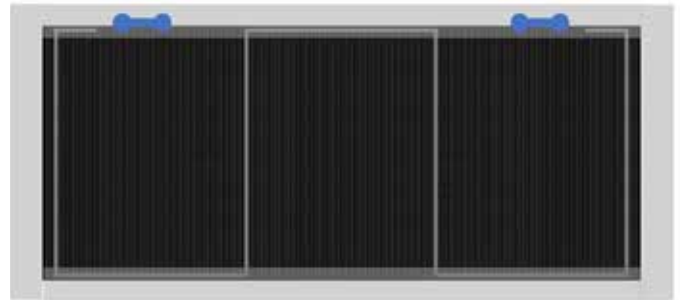

Figure 26 GR Inlet cover

- 3.** With a soft brush clean away any dust from the motor and elements.
- 4.** Check the security of all the components
- 5.** Check for any signs of deterioration and replace components as necessary

- 6.** Inspect the wiring for damage, chaffing of the outer case, damage cut or crushed and security in the terminals
- 7.** Check that the fuses are rated correctly.
- 8.** Clean the honeycomb outlet

Inlet foam filter replacement GS



MS

Figure 27 GS inlet foam retaining clip 1

- 1.** Remove and replace the foam inlet filter, by unhooking the leg of the clip and passing it through the dog bone hole in the frame, then release the remaining parts of the clip to allow the foam filter to be removed and replaced. Carefully refit the clip and ensure the foam is not creased and secure.

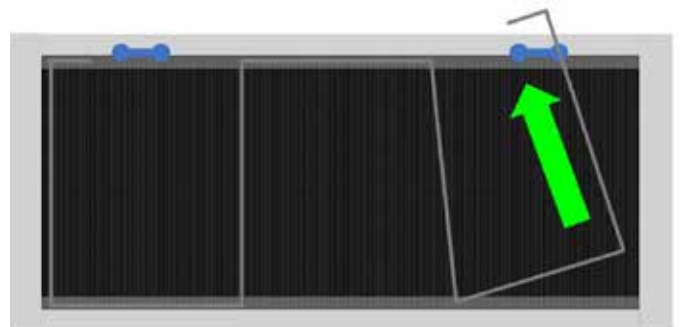

Figure 27.1 GS removing the inlet foam retaining clip

Inlet foam filter replacement GR

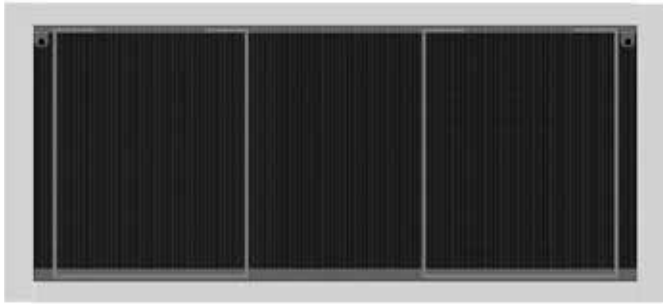

Figure 28 GR inlet foam retaining clip 1

MS

1. To remove the filter element of the GR units, select the clip from either end of the panel, push the outside leg of the retaining clip towards the centre of the filter/inlet grille which will release the clip out of the inlet grille frame, work along the clip releasing until the clip is fully out of the frame.
2. The filter element can now be removed and replaced with a new element reverse the procedure to refit and re-secure

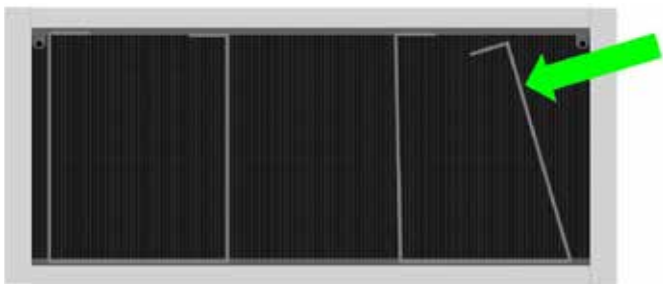

Figure 28.1 GR removing the inlet foam retaining clip

Honeycomb outlet replacement

To remove the honeycomb outlet, first remove the complete carrier. The carrier is secured at one end by a bolt and stud to the other end. Remove the end panel to access this fixing bolt and then release the carrier from the stud side, on the 2m models the centre support can be moved to one side to allow the stud side to be released

On the GS units peel back the tabs which retain the honeycomb outlet, remove the honeycomb media from the carrier and replace. Then fit the new honeycomb media into the carrier and push the tabs back over the honeycomb to secure

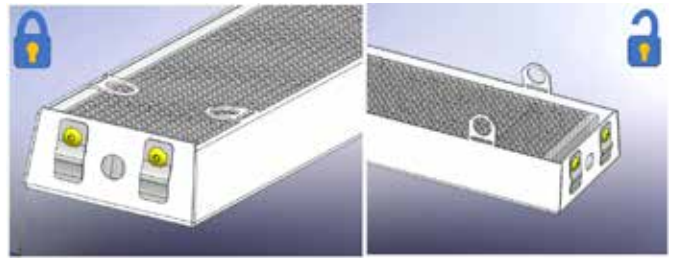

Figure 29 GS honeycomb retaining

On the GR units the tabs are part of a retaining plate, peel back the tabs which retain the honeycomb outlet remove the media from the carrier and replace. Then fit the new honeycomb media into the carrier and push the tabs back over the honeycomb to secure

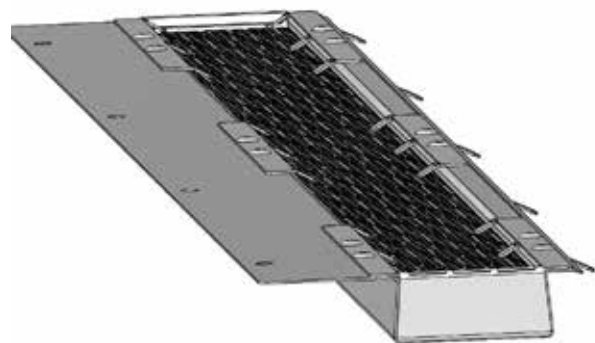

Figure 29.1 GR honeycomb retaining

Note the position of the temperature sensor from the right of the unit and ensure it does not get damaged, the cables will need to be disconnected from the control panel terminals TEMP, refit in the position given in figures 30 and table 9. (below)

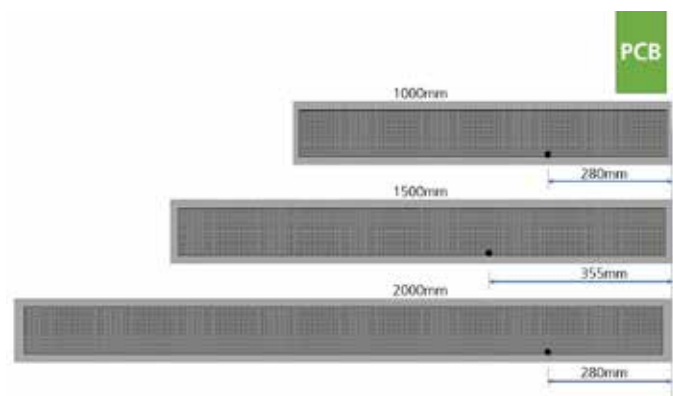

Figure 30 Temperature sensor position

Model length	Unit	Position from right
1 metre	mm	280
1.5 metre	mm	355
2 metre	mm	280

Table 9 Temperature sensor position

Fault finding.

General

All Air Curtains are fitted with fuse protection and motor thermal protection.

Other faults in relation to the element, motor and wiring should be identified using conventional fault-finding techniques.

In the event that electrical components are replaced, please ensure that electrical safety checks in accordance with the regulations in force in the country of use are undertaken.

Electric heated units only.

For the service engineer, please note that there is a thermal cut-out incorporated in the air curtain which needs to be manually reset. The cut-out is located near to the control panel, note 2m has two, with the second located near the centre of the fan deck.

Re-setting the thermal cut-out may help to identify the nature of the fault however we do not recommend re-setting without a thorough investigation into why the cut-out operated.



Figure 31 Thermal cut-out

Program panel.

The SmartElec3 circuit board within the electric heated models will communicate any potential faults to the program panel. Fault codes are displayed on the program panel as a code with a prefix "E" e.g. **0 E6**. The first number represents the air curtain

address.

For fault codes refer to SmartElec fault table on page 34

As the faults are mutually exclusive, the first error code displayed on the program panel will stay on until the fault has been cleared.

Apart from the communication failure fault **0 --** which could be due to a broken connection of the data link and the air curtain not found fault, **E rr** which could be due to incorrect addressing, all other faults will cause the base unit to switch off the heater output.

The SmartElec circuit board is protected from any short circuit of the air sensor **0 E1** or heat sink sensor **0 E4** as the error will cause the temperature to rise and trigger over temperature fault. **0 E1**

There are five basic checks to perform should 'X--' **0 --** appear on the program panel display. These are as follows:

- **Continuity:** Use a multimeter to check continuity between each end of the cable cores.
- **Short circuit:** Use a multimeter to check that there are no short circuits between any of the cable cores.
- **Plugs:** Check that the plugs are firmly seated in the circuit board sockets in both the program panel and on the circuit board .
- **Addressing:** (Network versions only). If two or more air curtains are networked, check that each base unit has a unique address as described in air curtain addressing on page 22.
- **Network cables:** Ensure that the total run of all cables in the network does not exceed 100m including the cable to the program panel.

If a program panel has never before been run, it automatically starts in engineer's mode when first powered-up. To exit this mode, press and hold the **+** Button.

Alternatively, the engineer's mode automatically self-clears after approximately 10 minutes of non-activity on the switches.

The system can be reset by powering-up the panel whilst holding down both the **SELECT** and **-** buttons.

The display shows the 'start' pattern but then goes blank.

FF

Release the buttons where upon the display resumes and the system addressing commences,

finding only those air curtains which are actually connected and working.

If **E n9** appears on the display, press and hold the **+** button for a few seconds then release. The display will then return to the normal mode.

SmartElec fault codes

= Air curtain address#_ _, #E1, #E2, #E5 and #E6 codes also apply to to standard controller.

Code	Description	Symptom	Possible cause	Remedy
# _ _	Communications failure	No control on unit	Bad data cable connection Damaged cable	Check data cables and plugs Replace damaged cable
# E1	Air sensor failed	Fan operating, no heat	Air sensor cable disconnected Air sensor broken	Check cable Replace air sensor
# E2	Air sensor temp too high	Fan operating, no heat	High ambient air temperature Incorrect motor or fan deck rotation Motor failure	Check ventilation Check rotation of the fan deck Check motor, replace if necessary
# E3	Heatsink too hot	Fan operating, no heat	High ambient air temp/faulty circuit board	Replace SmartElec circuit board
# E4	Heatsink sensor failure	Fan operating, no heat	Heatsink sensor wiring disconnected/faulty Heatsink sensor faulty	Check wiring Replace SmartElec circuit board
# E5	Ext. temp sensor failure	Unit runs but no external temperature control	External temperature sensor faulty	Repair faulty wiring Replace faulty sensor
# E6	Overheat stat open circuit	Fan operating, no heat	Overheat stat open circuit	Replace overheat thermostat

Table 10 SmartElec fault codes

Spare parts.

Note Any spare part components that are not approved by the manufacturer could invalidate the approval of the appliance and validity of the warranty.

General

Right hand & left hand is when viewed from inside of the building, looking at the unit into the door opening.



Figure 32 Handing of the unit

	Component	1000	1500	2000
Generic components				
Fan deck assembly		1026174	1026175	1026174 x 2
Program panel		108221-RJ45-1		
Resistor		n/a	1037491	n/a
Honeycomb core		1026068	1026078	1026068
Inlet cover assembly GS		1026849		
Inlet cover assembly GR		1026662	1026163	1026829
Inlet cover filter only GS		1026664		
Filter securing clip GS		1026910		
Inlet cover filter only GR		1026665	1026835	1026665
Filter securing clip GR		1026962		
End cap GS left hand		1026505		
End cap GS right hand		1026506		
Control fuse T1H		100535		
Ambient Models				
Control panel (base unit)		AC-AMBI-RJ45		
Electric Heat Models				
Electric heater element		1026146	1026145	1026146
Control panel (base unit)		SELEC3BU45		
Thermal cut out		900001		
Jumper pack (high and low capacity)		1026901		
Heating element fuse		900471		
LPHW Models				
Control panel (base unit)		AC-AMBI-RJ45		
LPHW coil		1026692	1026693	1026694



Table 11 Spare parts

Parts replacement.



Warning
Ensure electrical power is isolated from the product.

For access follow steps as stated in Installation Section on page 14

1. GS units, remove all of the front covers, remove the cover plate to access the control panel, installers terminal block, resistor (1500 only) and fan deck (motor and fans).
2. GR units, completely remove the inlet panel

Control panel



Make a note of the wiring at the control panel. Make a note of the dip switch settings

Make a note of the installer terminal block wiring

SP

1. Disconnect the wires from the control panel terminals including the earth connections which are bolted to the chassis.
2. Disconnect the installer terminal block assembly by removing the two screws securing the block bracket to the control panel mounting plate
3. Remove the control panel, this is secured by two screws in the control panel mounting bracket situated to the top of the bracket furthest away from the honey comb outlet grille.
4. With the control panel out of the unit disconnect the blue wire [1] from the temperature sensor, see figure 33 for the location. Unscrew the eight screws securing the control board to the heat sink and mounting plate and lift off
5. Replace the control board and reverse the steps remembering to reconnect the temperature sensor wire which goes through the hole in the PCB
6. Reverse the steps to install the new control panel

Set the dip switch [2] of figure 33 for the location and follow the networking address settings. For more information see page 22.

Heating element

1. Follow steps to remove the covers
2. Remove the fixing bolts holding the honey comb outlet grill assembly and remove this.
3. Make a note of the wiring at the control panel for the heating element and the temperature sensor

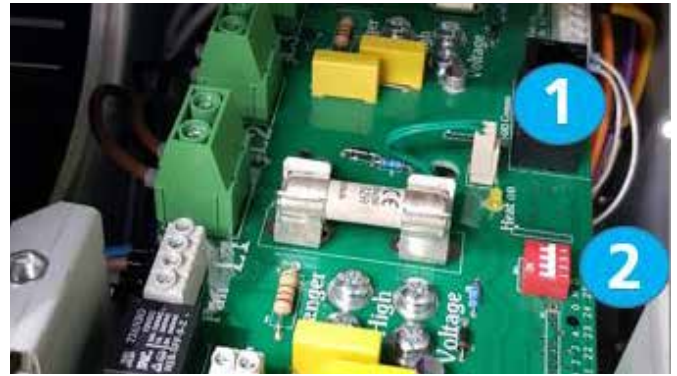

Figure 33 Control panel temperature sensor and dip switch location

4. Disconnect the wires at the heating element to the control panel
5. Remove the fixing bolts in the fan deck mounting plate which secures the heating element.
6. Remove the heating element
7. Make a note of the wiring to the heating element including all the jumper positions
8. Remove the wires and fit to the new element pass them through ready for connection to the control panel
9. Refit the heating element and reverse the steps to install the new heating element
10. Ensure the temperature sensor is refitted in the correct position and wired into the TEMP terminal of the control panel, see figure 30 and table 9 on page 32

Fan deck

1. Follow the steps to remove the covers and the control panel, complete with its mounting bracket as one of the fan deck securing nuts are under the control panel bracket.
2. With the control panel and bracket out of the unit disconnect the wire from the motor
3. Remove the wires to the thermal cut out sensor, (two sensors on the 2 metre units) and remove the thermal cut out.
4. Remove the four securing nuts, shake proof washer and flat washer that secure the fan deck.
5. Lift out the fan deck
6. Replace the deck and reverse the steps to install the new fan deck

LPHW Models - Water Coil Technical info



GS, GR & GB1000 Models		Flow/Return Temperature				
		82/71	80/70	70/60	60/50	50/40
Rating	kW	12.02	11.75	9.4	7.03	4.61
Temp. Rise	°C	14.2	13.9	11.1	8.3	5.4
Volumetric Fluid Flow	m³/h	1.0	1.0	0.8	0.6	0.4
Mass Fluid Flow	kg/h	938	1009	808	605	397
Fluid Velocity	m/s	1.66	1.79	1.42	1.06	0.69
Fluid Pressure Drop	kPa	13.13	14.99	10.41	6.46	3.19
Manifold Pressure Drop	kPa	1.39	1.6	1.04	0.6	0.27
Total Pressure Drop Fluid Side	kPa	14.52	16.58	11.45	7.05	3.45

GS, GR & GB1500 Models		Flow/Return Temperature				
		82/71	80/70	70/60	60/50	50/40
Rating	kW	18.93	18.48	14.9	11.3	7.67
Temp. Rise	°C	14.9	14.5	11.7	8.9	6
Volumetric Fluid Flow	m³/h	1.5	1.6	1.3	1	0.7
Mass Fluid Flow	kg/h	1477	1587	1281	973	661
Fluid Velocity	m/s	2.62	2.81	2.26	1.7	1.15
Fluid Pressure Drop	kPa	43.55	49.58	34.91	22.21	11.65
Manifold Pressure Drop	kPa	3.35	3.85	2.54	1.49	0.71
Total Pressure Drop Fluid Side	kPa	46.91	53.43	37.51	23.71	12.36

GS, GR & GB2000 Models		Flow/Return Temperature				
		82/71	80/70	70/60	60/50	50/40
Rating	kW	24.32	23.73	19.2	14.66	10.09
Temp. Rise	°C	14.4	14	11.3	8.7	6
Volumetric Fluid Flow	m³/h	1.9	2.1	1.7	1.3	0.9
Mass Fluid Flow	kg/h	1898	2037	1651	1262	869
Fluid Velocity	m/s	3.37	3.61	2.91	2.21	1.51
Fluid Pressure Drop	kPa	90.86	103.3	73.33	47.12	25.31
Manifold Pressure Drop	kPa	5.46	6.27	4.17	2.48	1.21
Total Pressure Drop Fluid Side	kPa	96.32	109.57	77.5	49.6	26.52



Nortek Global HVAC is a registered trademark of the Nortek Global HVAC limited. Because of the continuous product innovation, Nortek Global HVAC reserves the right to change product specification without due notice.

NORTEK GLOBAL HVAC (UK) LTD

Fens Pool Avenue
Brierley Hill
West Midlands DY5 1QA
United Kingdom
Tel +44 (0)1384 489250
Fax +44 (0)1384 489707
reznorsales@nortek.com
www.reznor.eu

This document replaces the previous, Manual Part No Reznor, Guardian GB GR and GS, Installation Manual, EN 2020-04, D301214 Iss A
Current full Part No. **Reznor, Guardian GB GR and GS, Installation Manual, EN 2020-06, D301214 Iss B**