

FLOOR STANDING HEATERS PK-N



PKA-N
PKE-N
EMS-N

CE



Installation,
use, and
maintenance instructions

Summary

1. GENERAL WARNINGS	3
2. SAFETY WARNINGS	3
2.1 Fuel	3
2.2 Gas Leaks	3
2.3 Power supply	4
2.4 Use	4
2.5 Packaging	4
2.6 Maintenance	4
2.7 Aeration	4
3. TYPE-TESTING AND APPROVAL CERTIFICATE.....	5
4. TECHNICAL FEATURES	6
4.1 Output vs. Efficiency % Diagrams.....	6
4.2 Technical Data Tables for PKA, PKE, and EMS.....	7
4.3 Technical Data Tables for PKA, PKE, and EMS ECA model type	9
4.4 Dimensions of Vertical Heaters Series PKA	11
4.5 Dimensions of Horizontal Heaters Series PKA	12
4.6 Dimensions of Vertical Heaters Series PKE.....	13
4.7 Dimensions of Horizontal Heaters Series PKE	14
4.8 Dimensions of Heaters Series EMS	15
4.9 Air Flow/Pressure Drop Charts for Heaters Series EMS-N.....	16
4.10 Technical Characteristics and Dimensions of Heaters Series POA	17
5. INSTRUCTIONS TO THE USER	18
5.1 Burner failure	18
6. INSTRUCTIONS TO THE INSTALLER	20
6.1 Electrical Wiring	20
6.2 Burner Control Wiring	20
6.3 Burner Wiring	21
6.4 POA Electrical Wiring	21
6.5 Thermostat Connection and Regulation	22
6.6 Burner Nozzle and Plate	23
6.6 Optional Components	24
7. INSTRUCTIONS TO THE SERVICE CENTRE	31
7.1 Electrical Components and Wiring Diagrams	31
7.2 Electrical Motor Wiring	40
7.3 First Start-up Check.....	41
8. COUPLING HEATERS-BURNERS.....	42

1. GENERAL WARNINGS

This Instruction Manual is an integral and essential part of the supply and shall be delivered to the user.

If the unit is sold or transferred to another owner, make sure that the manual follows it, so that the new installer/owner can read it.

Any manufacturer's liability (under contract provisions or otherwise) for damage to persons, animals, or objects resulting from wrong installation or misuse, and/or non compliance with the manufacturer's instructions, shall be expressly excluded. This unit is intended only and exclusively for the use for which it has been built. Any different, wrong, or unreasonable use is to be considered improper and therefore dangerous.

For unit installation, operation, and maintenance the user shall strictly follow instructions given in this manual.

Any installation, maintenance or servicing operations shall be performed only by authorized personnel, strictly complying to the instructions supplied in this manual.

The heater must be installed in compliance with existing laws and according to the manufacturer's instructions, by qualified personnel with specific technical knowledge in the heating field.

The unit is guaranteed according to the conditions specified in the warranty certificate.

The manufacturer certifies that the unit is built with state-of-the-art techniques and complies with UNI, UNI-CIG, CEI, and 90/396/CEE regulations on gas appliances.

2. SAFETY WARNINGS

The following symbol is used in this manual to draw the attention of the user:



Accident-prevention rules for the user and workers nearby

The following paragraphs contain safety rules relevant to installation room and aeration openings.

2.1 Fuel

A suitable burner must be mounted on the heater. Choose it according to the fuel to be used.

The burner must burn the fuel for which it has been built, which is specified on the plate and in the requirements section in the burner's manual.

In case of a gas burner, the gas supply pressure to the burner and the combustion head must fall within the range specified in the manual.

Before starting the heater, check that:

- Gas supply specifications match those on the heater data plate;
- Combustion air intake does not allow any obstructions of the air intake grid
- Internal and external sealing of the fuel supply system are tested in compliance with the law;
- Fuel type matches burner setting;
- The installation is correctly sized to match required flow and includes all safety and control devices required by the law;
- Gas pipes and air distribution ducts for canalized heaters have been properly cleaned;
- Fuel capacity adjustment matches equipment power rating;
- Fuel supply pressure matches the values on the data plate.

2.2 Gas Leaks

If you smell gas:

- Do not operate electrical switches, telephone or any other object or device that can cause sparks;
- Immediately open doors and windows to change the air in the room;
- Close gas valves;
- Ask for the intervention of **qualified personnel**.

2.3 Power supply

The heater must be properly connected to a safe grounding system, according to the law (CEI 64-8).

Warnings:

- Check the grounding system or have it checked by qualified personnel, if necessary.
- Make sure that power supply corresponds to the unit rated input shown on the data plate and in this manual.
- Do not exchange neutral with phase.
- The heater can be connected to power supply with a plug-socket only if this does not allow the exchange of phase with neutral.
- The system wire gauge and in particular the section of cables,

must be suitable for the unit rated input power shown on the data plate and in this manual.

- Do not pull electrical cables and keep them away from any sources of heat.

REMARK: A multipole switch with fuses and contact opening greater than 3 mm should be installed before the supply cable, in a visible and accessible position and nearer than 3 meters to the control board. Any installation or maintenance operation on the electrical system must be accomplished by qualified personnel.

2.4 Use

Children or inexperienced people shall not be allowed to use any electrical appliance and users shall adopt following precautions:

- do not touch the unit with wet or damp parts of the body and/or barefoot;
- do not leave the unit exposed to adverse weather conditions (rain, sunshine, etc.) unless the unit has been expressly designed to;
- do not use gas pipes to ground electrical appliances.
- do not wet the unit either with water or other liquids;
- do not put any objects on the unit;
- do not touch moving parts of the heater while it is working.

Do not touch hot surfaces of the heater. These parts, generally near the flame, become overheated during operation and remain hot even long after the burner has stopped.

If the unit is not used for a long time, open the main switch and close the manual cutoff valve on the fuel supply to the burner. If the unit is to be definitively stopped, do the following:

- have the main power supply disconnected by qualified personnel;
- close the manual cutoff valve on fuel supply and remove or seal the control wheel.

2.5 Packaging

Unpack the unit and make sure the contents have suffered no damage. In case of doubt, do not use the heater and contact the supplier. Dispose of packaging material (wooden crate, nails, fasteners, plastic bags, foamed polystyrene, etc.) according to national regulations.

2.6 Maintenance

Before any servicing or cleaning, disconnect power and gas supply.

In case of failure and/or improper operation, switch off the heater and do not attempt to repair it directly. Contact the Nordair-Niche Service Centre.

Use only original spare parts for repairs. Should the above mentioned instructions not be followed, the unit safety could be compromised and the warranty is invalidated.

2.7 Aeration

It is mandatory to properly and permanently aerate rooms where air heaters are installed. For instructions and regulations on this subject, refer to national laws and rules.

4. TECHNICAL FEATURES

There are three types of air heaters:

- PKA-N series - heaters with exchanger, fan group and control panel;
- PKE-N series - heaters with exchanger, fan group, control panel, and burner housing for outdoor installation;
- EMS series - heaters without fan group and control panel, equipped only with exchanger;

Each type of heater has been tested and approved for a specific duty and can be used at different ratings with different efficiency levels, according to the output. When choosing a model, please consider final use (heating, process plants, other), type of duty (season or continuous), and type of burner installed (on-off, two-stage or modulating).

For instance, if an output of 160 kW is required, you can choose among various models: 140N (88.5% efficiency), 190N (92% efficiency), and 250N (93.8% efficiency).

If a heater is dedicated to heating purposes only and uses an

on-off burner, model 190N is the most suitable. If a two-phase or modulating burner is installed, model 140N would be better (the burner and, therefore, the heater would work at maximum power for short periods). If the heater is used for process installation and works all year long, model 250N would probably be the best choice (higher cost would be balanced out by higher efficiency).

Operating curves of models PKA032 and PKA100N correspond to curves of models PKA035N and PKA120N, up to outputs of 32kW and 100kW.

4.1 Output vs. Efficiency % Diagrams

KG0100.EG.001

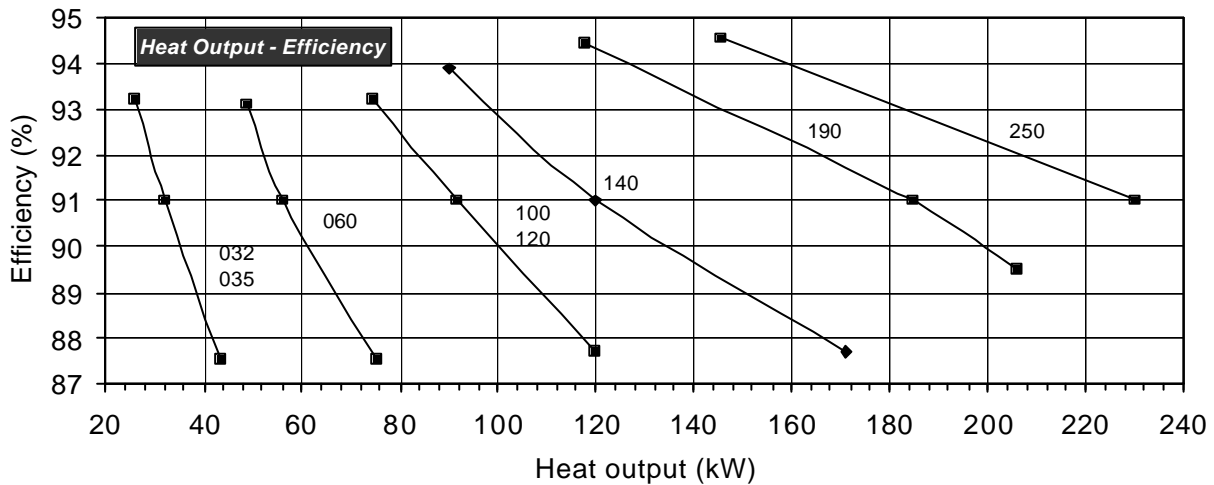

KG0100.EG.002

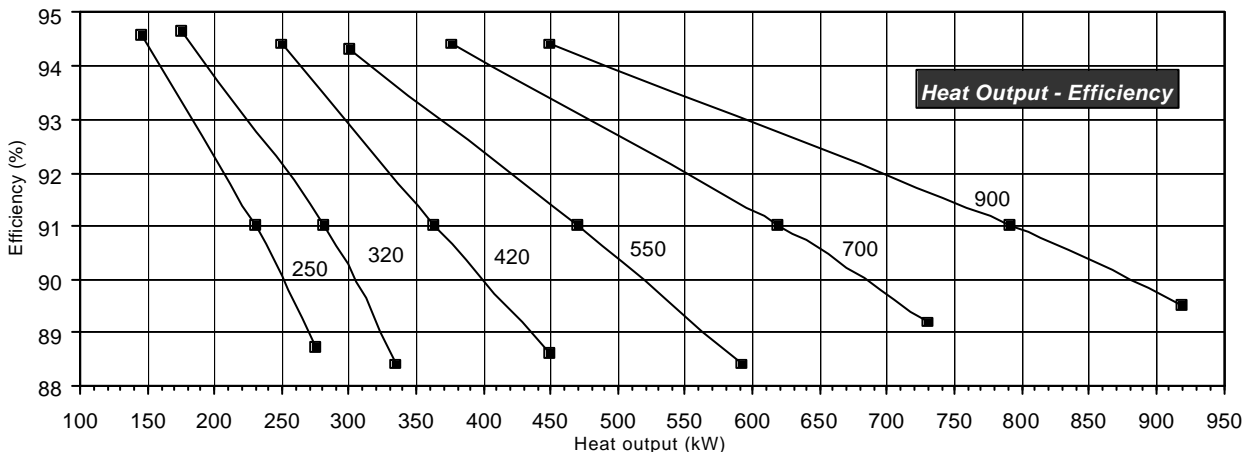

FLOOR STANDING HEATERS PK-N



4.2 Technical Data Tables for PKA, PKE, and EMS

Technical data for PKA and PKE models are the same.

Technical data for PKA and EMS models are the same up to the backpressure row, while data concerning air flow, prevalence and rating depend on the fan assembly.

Type		PKA032N		PKA035N		PKA060N		PKA100N		PKA120N	
		min.	max.	min.	max.	min.	max.	min.	max.	min.	max.
Heat Input	kW	28,0	34,8	28,0	49,5	50,3	86,0	80,0	110,7	80,0	137,0
Heat Output	kW	26,1	31,6	26,1	43,3	46,8	75,3	74,6	100,1	74,6	120,1
Efficiency	%	93,2%	90,8%	93,2%	87,5%	93,1%	87,5%	93,2%	90,4%	93,2%	87,7%
Backpressure	Pa	7	15	7	17	11	25	14	32	14	40
Air Flow 15°C	m ³ /h	2.700		2.700		5.000		7.300		7.300	
Air ΔT	°C	26,8	33,6	26,8	44,5	26,0	41,7	28,3	38,0	28,3	45,6
Static	Vers.00A	90		90		70		80		80	
Pressure	Vers.10A	150		150		120		150		150	
Available Pa	Vers.20A	-		-		240		270		270	
Power Supply	V	230/1~50		230/1~50		400/3N~50*		400/3N~50		400/3N~50	
Number of motors and power rating (kW)	Vers.00A	1x0,25		1x0,25		1x0,75		1x1,10		1x1,10	
	Vers.10A	1x0,56		1x0,50		1x1,10		1x1,50		1x1,50	
	Vers.20A	-		-		1x1,50		1x2,20		1x2,20	
Sound pressure dB(A) measured at 3 m.	Vers.00A	62		62		65		66		66	
	Vers.10A	63		63		66		69		69	
	Vers.20A	-		-		67		70		70	

Type		PKA140N		PKA190N		PKA250N		PKA320N		PKA420N	
		min.	max.	min.	max.	min.	max.	min.	max.	min.	max.
Heat Input	kW	96,0	195,0	125,0	230,0	154,0	310,0	185,0	380,0	260,0	508,0
Heat Output	kW	90,1	171,0	118,0	205,9	145,6	275,0	175,1	335,9	245,4	450,1
Efficiency	%	93,9%	87,7%	94,4%	89,5%	94,6%	88,7%	94,6%	88,4%	94,4%	88,6%
Backpressure	Pa	13	50	10	40	10	50	15	60	28	120
Air Flow 15°C	mc/h	10.500		14.000		18.000		23.000		30.500	
Air ΔT	°C	23,8	45,2	23,4	40,8	22,4	42,4	21,1	40,5	22,3	40,9
Static	Vers.00A	70		70		70		70		70	
Pressure	Vers.10A	140		150		130		210		180	
Available Pa	Vers.20A	280		230		250		320		270	
Power Supply	V	400/3N~50		400/3N~50		400/3N~50		400/3N~50		400/3N~50	
Number of motors and power rating (kW)	Vers.00A	1x3,00		1x3,00		2x2,20		2x2,20		2x4,00	
	Vers.10A	1x3,00		1x3,00		2x2,20		2x3,00		2x5,50**	
	Vers.20A	1x4,00		1x4,00		2x3,00		2x4,00		2x5,50**	
Sound pressure dB(A) measured at 3 m.	Vers.00A	65		68		68		68		72	
	Vers.10A	66		72		72		72		75	
	Vers.20A	68		74		74		76		77	

Type		PKA550N		PKA700N		PKA900N	
		min.	max.	min.	max.	min.	max.
Heat Input	kW	320,0	670,0	397,0	818,0	477,0	1028,0
Heat Output	kW	301,0	592,3	375,0	729,7	450,0	920,1
Efficiency	%	94,3%	88,4%	94,4%	89,2%	94,4%	89,5%
Backpressure	Pa	21	110	25	120	28	130
Air Flow 15°C	mc/h	40.000		54.000		68.500	
Air ΔT	°C	21,0	41,0	19,9	38,8	18,8	38,5
Static Pressure	Vers.00A	70		90		90	
Available Pa	Vers.10A	180		240		260	
Power Supply	Vers.20A	280		350		400	
Number of motors and power rating (kW)	V	400/3N~/50		400/3N~/50		400/3N~/50	
	Vers.00A	2x3,00		2x4,00		2x5,50**	
	Vers.10A	2x4,00		2x5,50**		2x7,50**	
	Vers.20A	2x5,50**		2x7,50**		2x11,00**	
Sound pressure dB(A) measured at 3 m.	Vers.00A	70		70		70	
	Vers.10A	72		72		72	
	Vers.20A	74		74		78	

FLOOR STANDING HEATERS PK-N



4.3 Technical Data Tables for PKA, PKE, and EMS ECA model type

THIS TABLE IS FOR U.K. MARKET ONLY.

Technical data for PKA and PKE models are the same.

Technical data for PKA and EMS models are the same up to the backpressure row, while data concerning air flow, prevalence and rating depend on the fan assembly

Type		PKA032N		PKA035N		PKA060N		PKA100N		PKA120N	
		min.	max.	min.	max.	min.	max.	min.	max.	min.	max.
Heat Input	kW	28,0	34,8	28,0	35,0	50,3	61,5	80,0	101,0	80,0	101,0
Heat Output	kW	26,1	31,6	26,1	31,9	46,8	56,0	74,6	91,9	74,6	91,9
Efficiency	%	93,2%	91,0%	93,2%	91,0%	93,1%	91,0%	93,2%	91,0%	93,2%	91,0%
Backpressure	Pa	7	15	7	17	11	25	14	32	14	40
Air Flow 15°C	m ³ /h	2.700		2.700		5.000		7.300		7.300	
Air ΔT	°C	26,8	33,6	26,8	33,8	26,0	32,1	28,3	36,1	28,3	36,1
Static	Vers.00A	90		90		70		80		80	
Pressure	Vers.10A	150		150		120		150		150	
Available Pa	Vers.20A	-		-		240		270		270	
Power Supply	V	230/1~50		230/1~50		400/3N~50*		400/3N~50		400/3N~50	
Number of motors	Vers.00A	1x0,25		1x0,25		1x0,75		1x1,10		1x1,10	
and power	Vers.10A	1x0,56		1x0,50		1x1,10		1x1,50		1x1,50	
rating (kW)	Vers.20A	-		-		1x1,50		1x2,20		1x2,20	
Sound pressure	Vers.00A	62		62		65		66		66	
dB(A)	Vers.10A	63		63		66		69		69	
measured at 3 m.	Vers.20A	-		-		67		70		70	

KG0100.ET.001

Type		PKA140N		PKA190N		PKA250N		PKA320N		PKA420N	
		min.	max.	min.	max.	min.	max.	min.	max.	min.	max.
Heat Input	kW	96,0	132,0	125,0	203,0	154,0	253,0	185,0	310,0	260,0	400,0
Heat Output	kW	90,1	120,1	118,0	184,7	145,6	230,2	175,1	282,1	245,4	364,0
Efficiency	%	93,9%	91,0%	94,4%	91,0%	94,6%	91,0%	94,6%	91,0%	94,4%	91,0%
Backpressure	Pa	13	50	10	40	10	50	15	60	28	120
Air Flow 15°C	mc/h	10.500		14.000		18.000		23.000		30.500	
Air ΔT	°C	23,8	32,8	23,4	37,8	22,4	36,7	21,1	35,8	22,3	34,2
Static	Vers.00A	70		70		70		70		70	
Pressure	Vers.10A	140		150		130		210		180	
Available Pa	Vers.20A	280		230		250		320		270	
Power Supply	V	400/3N~50		400/3N~50		400/3N~50		400/3N~50		400/3N~50	
Number of motors	Vers.00A	1x3,00		1x3,00		2x2,20		2x2,20		2x4,00	
and power	Vers.10A	1x3,00		1x3,00		2x2,20		2x3,00		2x5,50**	
rating (kW)	Vers.20A	1x4,00		1x4,00		2x3,00		2x4,00		2x5,50**	
Sound pressure	Vers.00A	65		68		68		68		72	
dB(A)	Vers.10A	66		72		72		72		75	
measured at 3 m.	Vers.20A	68		74		74		76		77	

KG0100.ET.002

* SINGLE-PHASE POWER SUPPLY FOR 00A MODEL

** STAR/DELTA START-UP

Type		PKA550N		PKA700N		PKA900N	
		min.	max.	min.	max.	min.	max.
Heat Input	kW	320,0	517,0	397,0	680,0	477,0	870,0
Heat Output	kW	301,0	470,5	375,0	618,8	450,0	791,7
Efficiency	%	94,3%	91,0%	94,4%	91,0%	94,4%	91,0%
Backpressure	Pa	21	110	25	120	28	130
Air Flow 15°C	mc/h	40.000		54.000		68.500	
Air ΔT	°C	21,0	33,7	19,9	32,8	18,8	33,1
Static	Vers.00A	70		90		90	
Pressure	Vers.10A	180		240		260	
Available Pa	Vers.20A	280		350		400	
Power Supply	V	400/3N~/50		400/3N~/50		400/3N~/50	
Number of motors	Vers.00A	2x3,00		2x4,00		2x5,50**	
and power	Vers.10A	2x4,00		2x5,50**		2x7,50**	
rating (kW)	Vers.20A	2x5,50**		2x7,50**		2x11,00**	
Sound pressure	Vers.00A	70		70		70	
dB(A)	Vers.10A	72		72		72	
measured at 3 m.	Vers.20A	74		74		78	

KG0100.ET.003

* SINGLE-PHASE POWER SUPPLY FOR 00A MODEL

** STAR/DELTA START-UP

FLOOR STANDING HEATERS PK-N

4.4 Dimensions of Vertical Heaters Series PKA

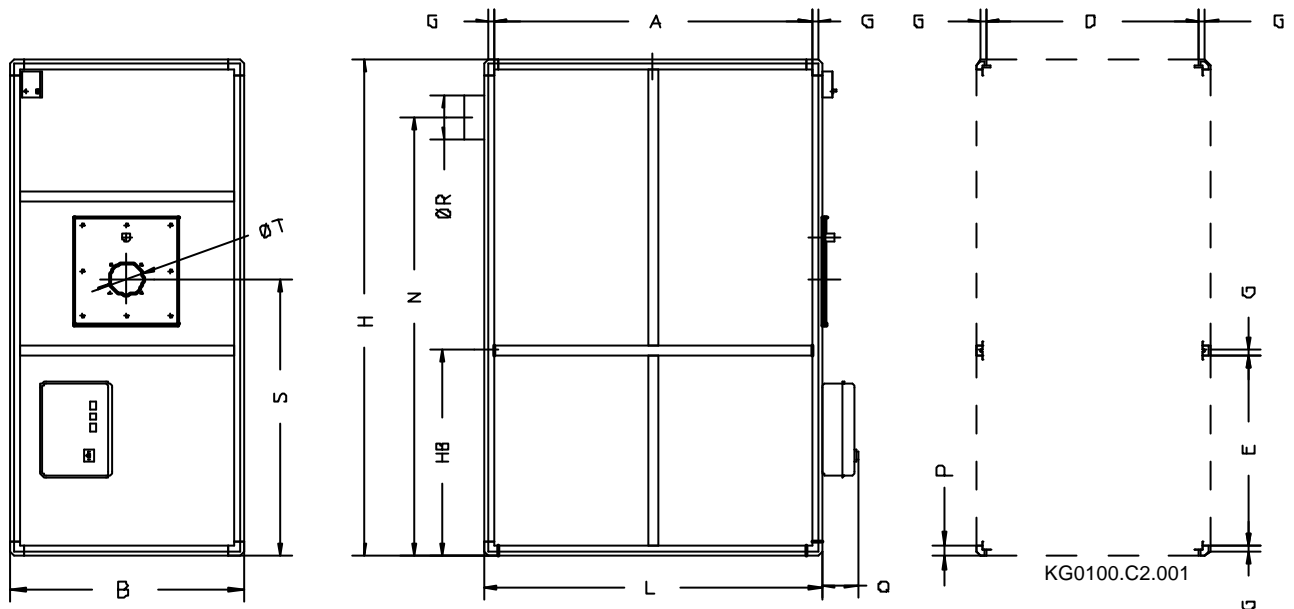

Type	Dimensions				Air Inlet		Air Outlet		Profile		Chimney		Burner		Weight Kg.
	L	B	H	Hb	A	E	A	D	P	G	N	ØR	S	ØT	
PKA032N-035N	750	530	1.490		670	590	670	450	40	25	1.208	120	860	135	116
PKA060N	995	700	1.680		915	650	915	620	40	25	1.417	150	940	135	174
PKA100N-120N	1.100	800	2.020		1.020	800	1.020	720	40	25	1.760	180	1.155	190	246
PKA140N	1.330	920	2.080		1.250	800	1.250	840	40	25	1.800	180	1.155	190	320
PKA190N	1.460	1.060	2.230		1.380	800	1.380	980	40	25	1.960	250	1.190	190	382
PKA250N	1.750	1.140	2.330		1.670	800	1.670	1.060	40	25	2.040	250	1.220	190	506
PKA320N	1.960	1.140	2.330		1.880	800	1.880	1.060	40	25	2.040	250	1.180	230	574
PKA420N	2.170	1.340	2.800	1.000	2.070	900	2.070	1.240	50	30	2.480	300	1.440	230	902
PKA550N	2.600	1.340	3.170	1.290	2.500	1.190	2.500	1.240	50	30	2.800	300	1.730	230	1.148
PKA700N	2.950	1.600	3.400	1.290	2.850	1.190	2.850	1.500	50	30	2.880	350	1.790	290	1.560
PKA900N	3.550	1.700	3.750	1.420	3.450	1.320	3.450	1.600	50	30	3.060	400	1.850	290	1.940

KG0100.ET.004

All supplied models up to 320 are monobloc (pre-installed burner housing); from model 420 onwards, heaters are split into a fan assembly and an exchanger group.

Standard air inlet is on the right hand side of the heater (front side is where the burner is mounted). Upon request, the installer and/or the manufacturer can move the grid on left side.

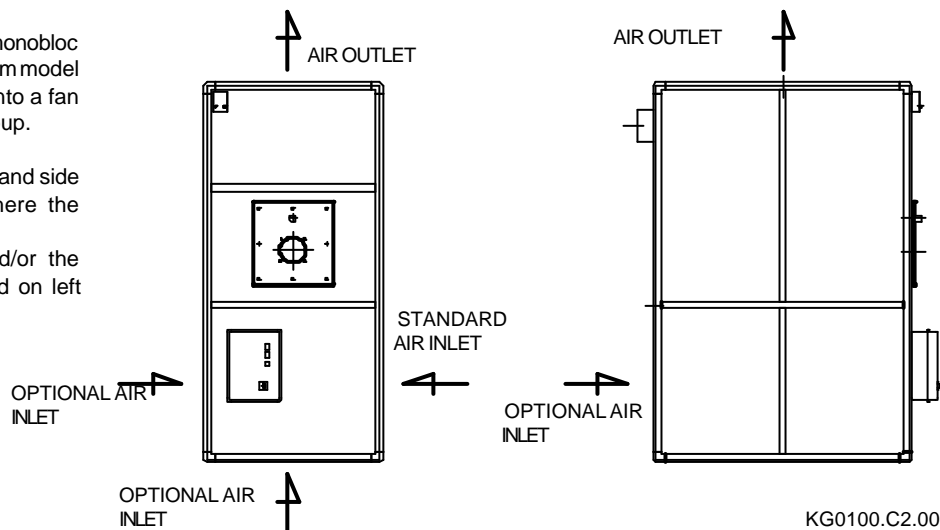

KG0100.C2.002

4.5 Dimensions of Horizontal Heaters Series PKA

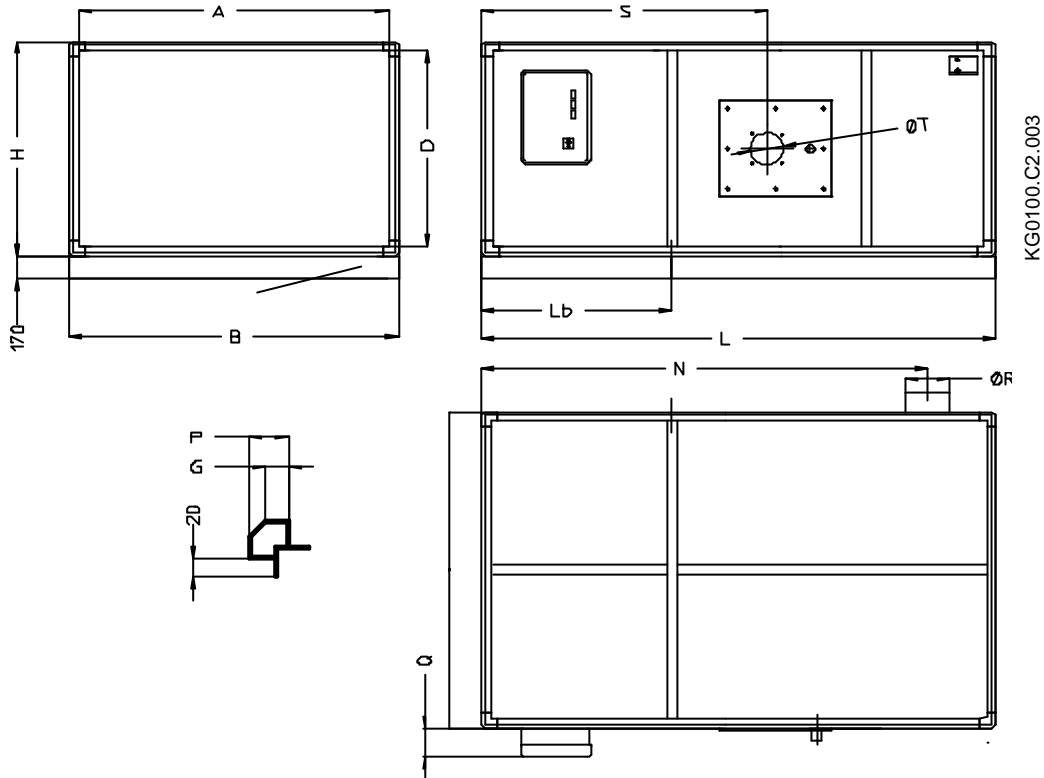

KG0100.C2.003

KG0100.EI.005

Type	Dimensions				Air Inlet		Air Outlet		Profile		Chimney		Burner		Weight Kg.
	B	H	L	Lb	A	E	A	D	P	G	N	Ø R	S	Ø T	
PKA032N-035N	750	530	1.490		670	590	670	450	40	25	1.208	120	860	135	116
PKA060N	995	700	1.680		915	650	915	620	40	25	1.417	150	940	135	174
PKA100N-120N	1.100	800	2.020		1.020	800	1.020	720	40	25	1.760	180	1.155	190	246
PKA140N	1.330	920	2.080		1.250	800	1.250	840	40	25	1.800	180	1.155	190	320
PKA190N	1.460	1.060	2.230		1.380	800	1.380	980	40	25	1.960	250	1.190	190	382
PKA250N	1.750	1.140	2.330		1.670	800	1.670	800	40	25	2.040	250	1.220	190	506
PKA320N	1.960	1.140	2.330		1.880	800	1.880	1.060	40	25	2.040	250	1.180	230	574
PKA420N	2.170	1.340	2.800	1.000	2.070	900	2.070	1.240	50	30	2.480	300	1.440	230	902
PKA550N	2.600	1.340	3.170	1.290	2.500	1.190	2.500	1.240	50	30	2.800	300	1.730	230	1.148
PKA700N	2.950	1.600	3.400	1.290	2.850	1.190	2.850	1.500	50	30	2.880	350	1.790	290	1.560
PKA900N	3.550	1.700	3.750	1.420	3.450	1.320	3.450	1.600	50	30	3.060	400	1.850	290	1.940

All supplied models up to 320 are monobloc (pre-installed burner housing); from model 420 onwards, heaters are split into a fan assembly and an exchanger group.

For horizontal heaters, please specify air flow direction: from left to right (as shown in figure below) or from right to left (front side is where the burner is mounted).

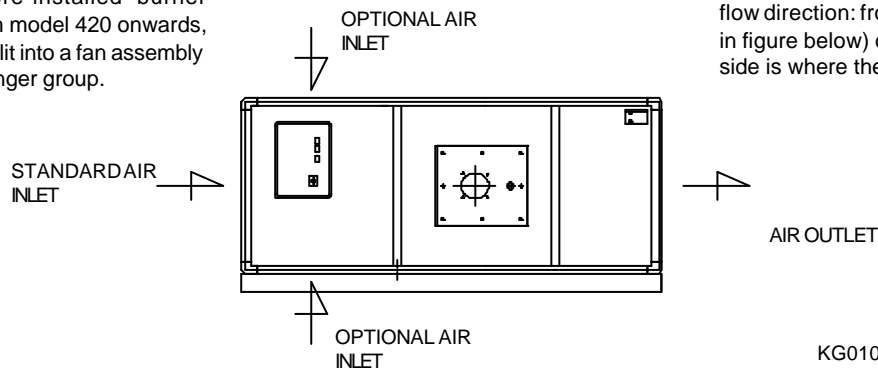

KG0100.C2.004

FLOOR STANDING HEATERS PK-N



4.6 Dimensions of Vertical Heaters Series PKE

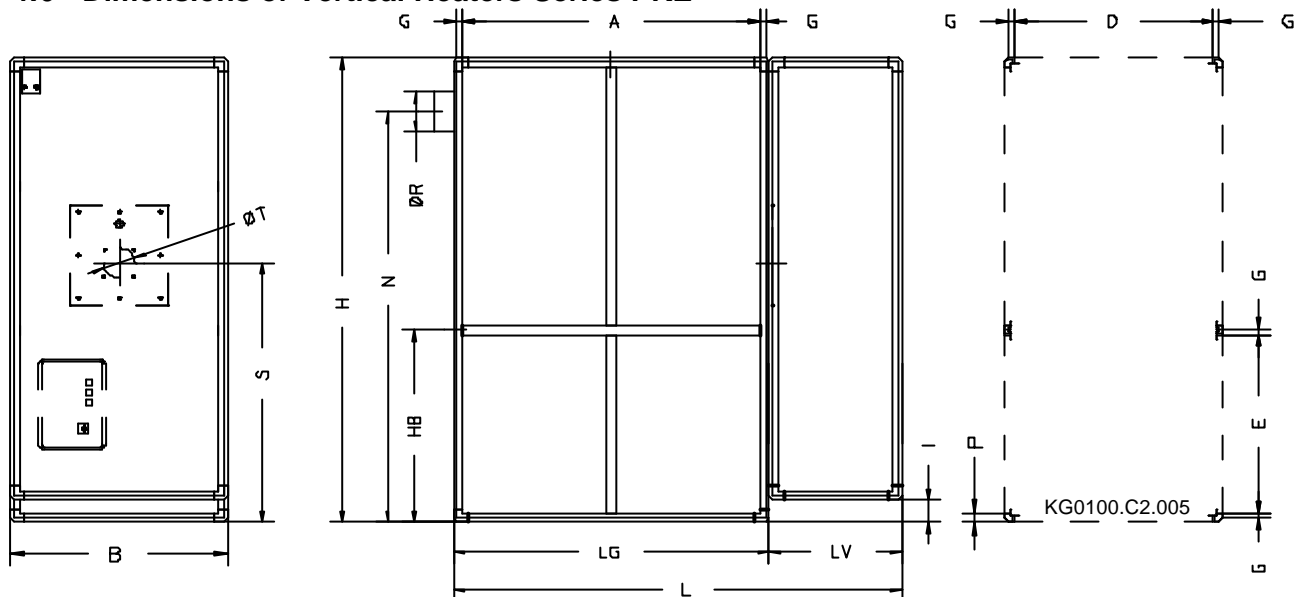

Type	Dimensions				Air Inlet		Air Outlet		Profile		Chimney		Burner		Burner Housing Weight			
	L	B	H	Hb	A	E	A	D	P	G	N	ØR	S	ØT	LG	LV	I	kg
PKE032N-035N	1.250	530	1.490	-	670	590	670	450	40	25	1.208	120	860	135	750	500	100	148
PKE060N	1.495	700	1.680	-	95	650	915	620	40	25	1.417	150	940	135	995	500	110	214
PKE100N-120N	1.600	800	2.020	-	1.020	800	1.020	720	40	25	1.760	180	1.190	135	1.100	500	150	292
PKE140N	1.930	920	2.080	-	1.250	800	1.250	840	40	25	1.800	180	1.155	190	1.330	600	60	378
PKE190N	2.190	1.060	2.230	-	1.380	800	1.380	980	40	25	1.960	250	1.190	190	1.460	730	150	460
PKE250N	2.550	1.140	2.330	-	1.670	800	1.670	1.060	40	25	2.040	250	1.220	190	1.750	800	100	592
PKE320N	2.760	1.140	2.330	-	1.880	800	1.880	1.060	40	25	2.040	250	1.180	230	1.960	800	100	660
PKE420N	3.070	1.340	2.800	1.000	2.070	900	2.070	1.240	50	25	2.480	300	1.440	230	2.170	900	200	1.006
PKE550N	3.500	1.340	3.170	1.290	2.500	1.190	2.500	1.240	50	25	2.800	300	1.730	230	2.600	900	200	1.284
PKE700N	3.950	1.600	3.400	1.290	2.850	1.190	2.850	1.500	50	25	2.880	350	1.790	290	2.950	1.000	200	1.710
PKE900N	4.550	1.700	3.750	1.420	3.450	1.320	3.450	1.600	50	25	3.060	400	1.850	290	3.550	1.000	200	2.110

All supplied models up to 320 are monobloc (pre-installed burner housing); from model 420 onwards, heaters are split into a fan assembly, an exchanger group, and a burner housing.

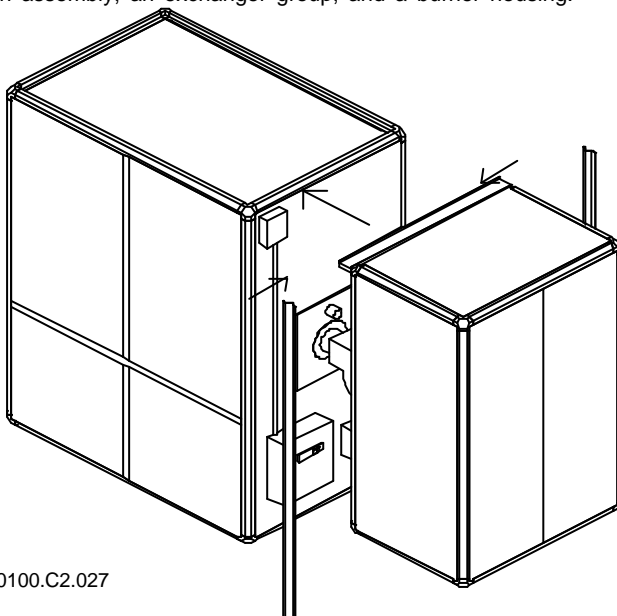

The picture in this page shows how to mount burner housing on PKE heaters. Follow these steps:

- lift up burner housing;
- lean upper support on the heater as well as side profiles, pre-assembled on the housing;
- fix support and profiles to the heater using supplied screws.

Then, in order to protect all internal parts (switchboard, burner, etc.) from water, seal any residual opening in joints with silicone.

KG0100.C2.027

4.7 Dimensions of Horizontal Heaters Series PKE

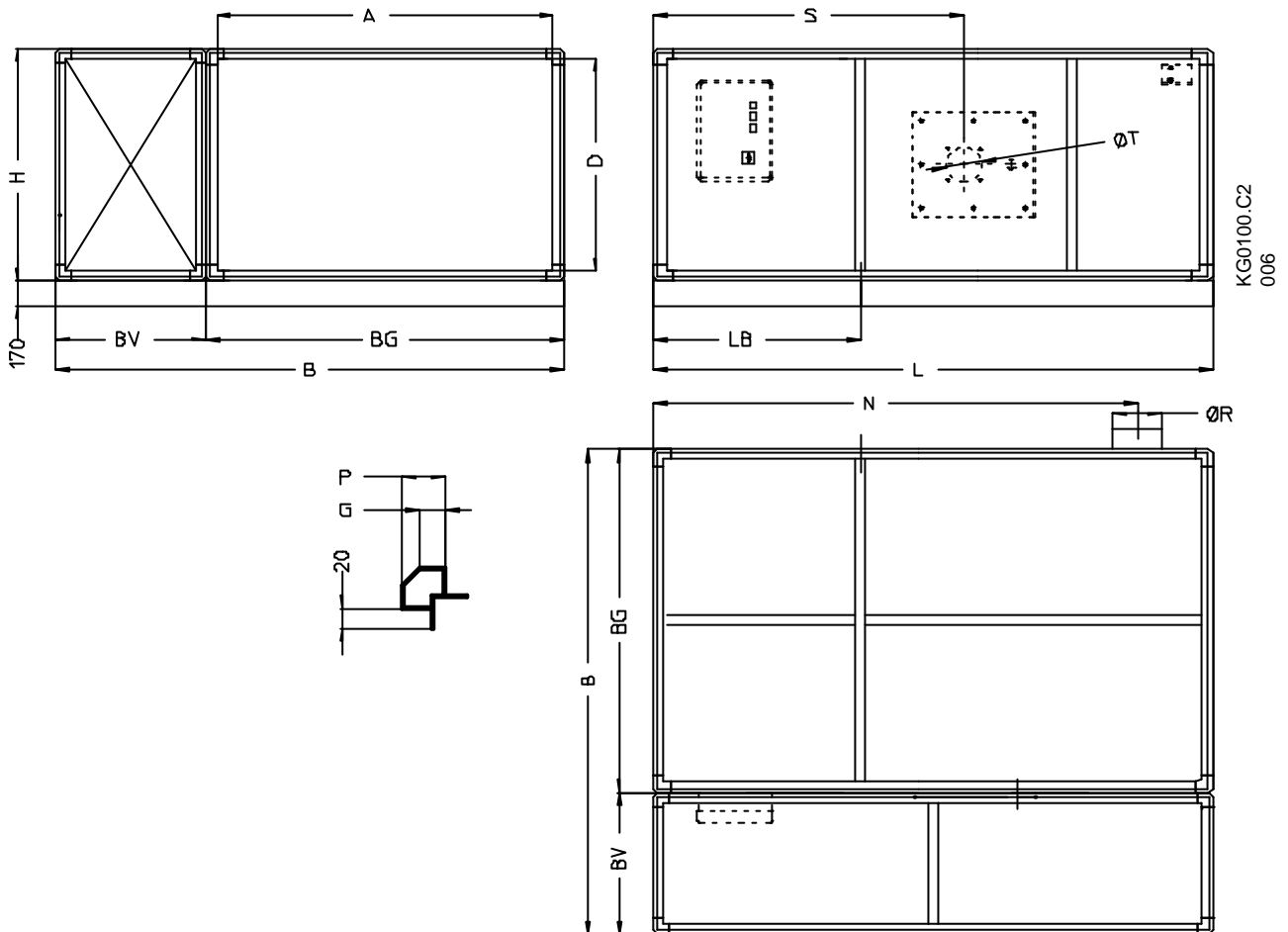

Type	Dimensions				Air Inlet		Air Outlet		Profile		Chimney		Burner		Burner Housing Weight		
	B	H	L	LB	A	D	A	D	P	G	N	ØR	S	ØT	BG	BV	KG
PKE032N-035N	1.250	530	1.490	-	670	590	670	450	40	25	1.208	120	860	135	750	500	148
PKE060N	1.495	700	1.680	-	915	650	915	620	40	25	1.417	150	940	135	995	500	214
PKE100N-120N	1.600	800	2.020	-	1.020	800	1.020	720	40	25	1.760	180	1.190	135	1.100	500	292
PKE140N	1.930	920	2.080	-	1.250	800	1.250	840	40	25	1.800	180	1.155	190	1.330	600	378
PKE190N	2.190	1.060	2.230	-	1.380	800	1.380	980	40	25	1.960	250	1.190	190	1.460	730	460
PKE250N	2.550	1.140	2.330	-	1.670	800	1.670	1.060	40	25	2.040	250	1.220	190	1.750	800	592
PKE320N	2.760	1.140	2.330	-	1.880	800	1.880	1.060	40	25	2.040	250	1.180	230	1.960	800	660
PKE420N	3.070	1.340	2.800	1.000	2.070	900	2.070	1.240	50	30	2.480	300	1.440	230	2.170	900	1.006
PKE550N	3.500	1.340	3.170	1.290	2.500	1.190	2.500	1.240	50	30	2.800	300	1.730	230	2.600	900	1.284
PKE700N	3.950	1.600	3.400	1.290	2.850	1.190	2.850	1.500	50	30	2.880	350	1.790	290	2.950	1.000	1.710
PKE900N	4.550	1.700	3.750	1.420	3.450	1.320	3.450	1.600	50	30	3.060	400	1.850	290	3.550	1.000	2.110

KG0100.ET.007

For horizontal heaters, you must specify air flow direction: from left to right (see picture code KG0100.C2.004 showing horizontal PKA) or from right to left (front side is where the burning is mounted).

All models up to 320 are supplied in one assembly (pre-installed burner housing); from model 420 onwards, heaters are supplied in three sections: fan assembly, exchanger group, and burner housing.

FLOOR STANDING HEATERS PK-N

4.8 Dimensions of Heaters Series EMS

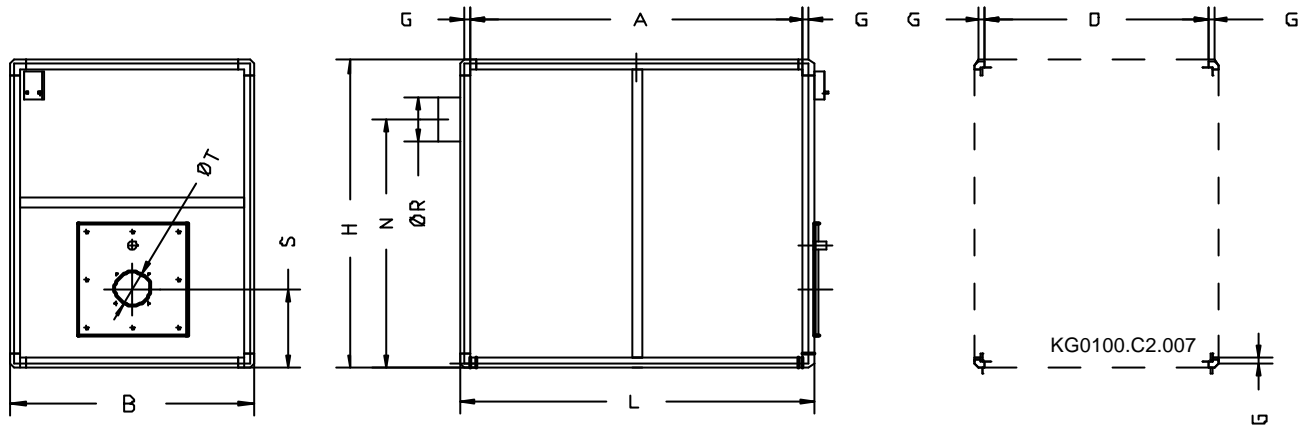

Type	Dimensions			Air inlet/outlet			Chimney		Burner		Weight kG
	L	B	H	A	D	G	N	ØR	S	ØT	
EMS032N-035N	750	530	860	670	450	40	577	120	230	135	70
EMS060N	995	700	990	915	620	40	727	150	248	135	100
EMS100N-120N	1.100	800	1.180	1.020	720	40	920	180	350	135	144
EMS140N	1.330	920	1.240	1.250	840	40	960	180	315	190	186
EMS190N	1.460	1.060	1.390	1.380	980	40	1.120	250	370	190	252
EMS250N	1.750	1.140	1.490	1.670	1.060	40	1.200	250	380	190	312
EMS320N	1.960	1.140	1.490	1.880	1.060	40	1.200	250	340	230	354
EMS420N	2.170	1.340	1.800	2.070	1.240	50	1.480	300	440	230	538
EMS550N	2.600	1.340	1.880	2.500	1.240	50	1.510	300	440	230	632
EMS700N	2.950	1.600	2.110	2.850	1.500	50	1.770	350	500	290	870
EMS900N	3.550	1.700	2.330	3.450	1.600	50	1.955	400	585	290	1.185

EMS-N modules are composed by an heat exchanger, a safety thermostat (limit), a fan thermostat, an aluminium frame covered by pre-painted sheet-zinc double-coating panels which provide thermal insulation.

Standard version can be connected to a duct system or leaned on a plenum for air delivery.

The module can be used either before or after the fan, on air inlet or outlet respectively.

Maximum air pressure in standard version is 400 Pa. However, versions with maximum air pressure of 2500 Pa can be manufactured upon request. Air flows and temperatures must match those of our heaters series PKA-N, with a tolerance of $\pm 10\%$. If the module is to be used at air flows and/or temperatures which differ from those indicated, it is necessary to consult Nordair-Niche staff.

An electrical switchboard and an air flow control device are supplied upon request. The control device operates directly on the burner. Versions with baseplate for floor installation are also available upon request .

LEFT-HAND AIR FLOW (EMS...-00ASX)

RIGHT-HAND AIR FLOW (EMS...-00ADX)

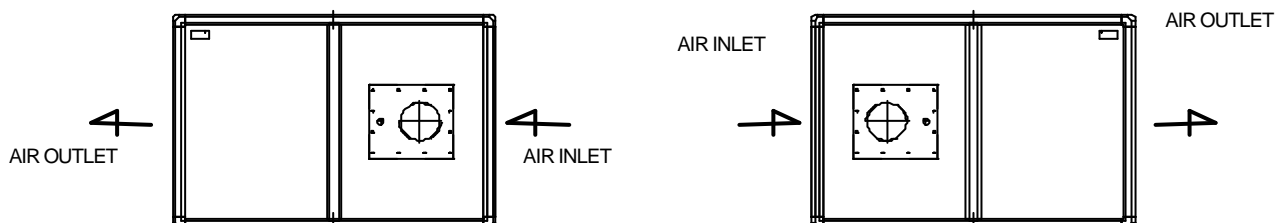

For horizontal installations, specify at order if air must flow rightwards or leftwards. This information is essential to correctly install the safety thermostat in the upper part of the heater. Codes: EMS...-00ASX for left-hand and EMS...-00ADX for right-hand air flow.

4.9 Air Flow/Pressure Drop Charts for Heaters Series EMS-N

KG0100EG003

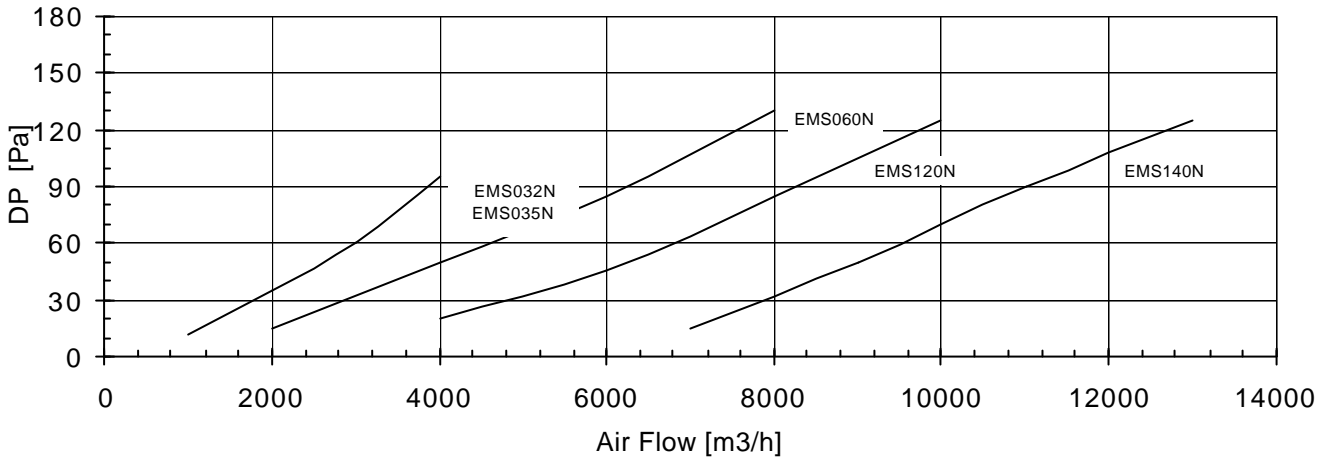

KG0100EG004

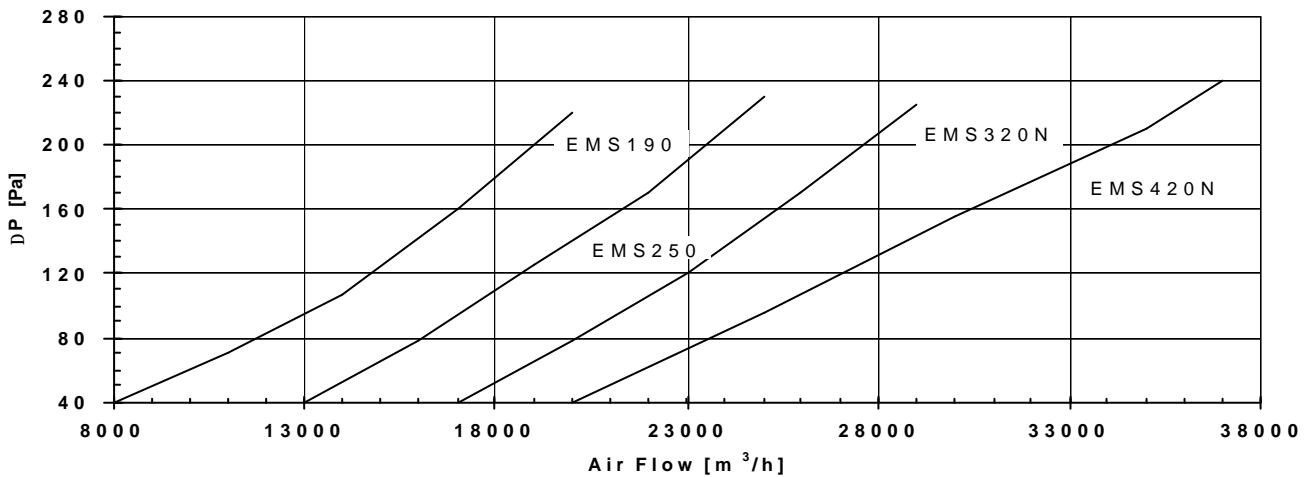

KG0100EG005

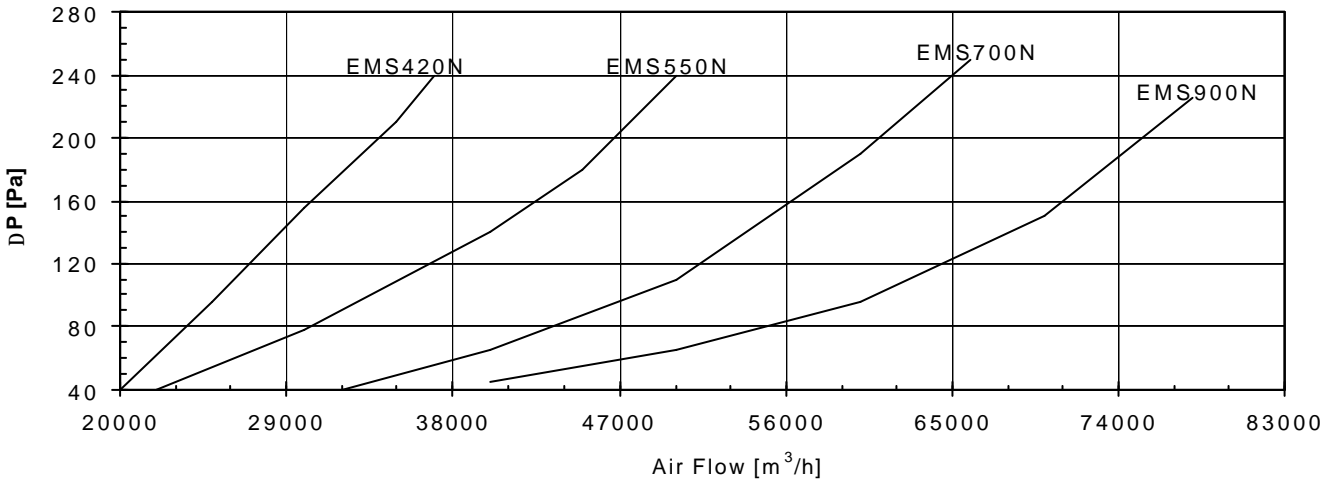

4.10 Technical Characteristics and Dimensions of Heaters Series P0A

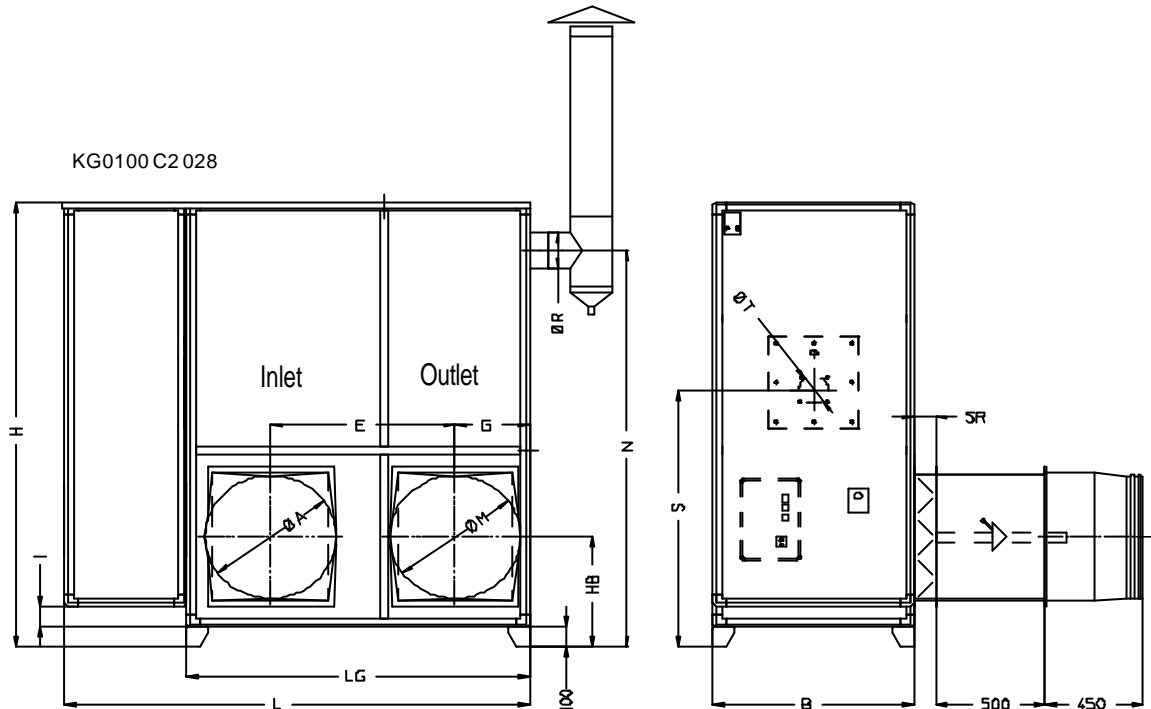

P0A Heater	Dimensions			Inlet and Outlet				Chimney		Burner		Weight kg			
	B	H	L	ØA	ØM	E	G	SR	HB	ØR	N		LG	S	I
PKE100N-120N	800	2120	1955	500	500	700	285	80	540	180	1860	1455	290	150	444
PKE140N	920	2180	2170	600	600	865	365	130	540	180	1900	1570	1235	60	524
PKE190N	1060	2330	2480	600	700	925	385	130	540	250	2060	1750	1290	150	648
PKE250N	1140	2430	2760	600	700	1110	410	130	540	250	2140	1960	1320	100	810
PKE320N	1140	2610	3110	900	900	1135	515	250	630	250	2320	2310	1460	100	992

KG0100.ET.013

Heaters series PKE-N-P0A have been designed for the heating of pressurized or self-supporting coverings in tennis courts, swimming pools, gymnasiums, and deposits.

Standard heaters include the following items:

- flue evacuation chimney (T joint, 1 meter straight pipe, cover, condensate-collecting plug);
- fire stop gates on air inlet and outlet, RE1120 with cabled microswitch;
- nozzles with square-round fittings;
- manually regulated gate for recirculation;
- restoration grid with gravity lock;
- electronic room thermostat connected to a probe in the air inlet duct;
- 100 millimetre supports.

Smoke-stop gate with manual reset is supplied upon request.

KG0100 ET 014

		PKE100N		PKE120N		PKE140N		PKE190N		PKE250N		PKE320N	
		min.	max.	min.	max.	min.	max.	min.	max.	min.	max.	min.	max.
Heat Input	kW	80.0	110.7	80.0	137.0	96.0	195.0	125.0	230.0	154.0	310.0	185.0	380.0
	kcal/h	68,800	95,202	68,800	117,820	82,560	167,700	107,500	197,800	132,440	266,600	159,100	326,800
Heat Output	kW	74.6	100.0	74.6	120.1	90.1	171.1	118.0	205.9	118.0	205.9	175.1	335.9
	kcal/h	64,156	86,000	64,156	103,286	77,486	147,146	101,480	177,074	101,480	177,074	150,586	288,874
Efficiency	%	93.3%	90.3%	93.3%	87.7%	93.9%	87.7%	94.4%	89.5%	76.6%	66.4%	94.6%	88.4%
Back pressure	Pa	14	32	14	40	13	50	10	40	10	50	15	60
Air Flow 15°C	m³/h	7,000		7,000		9,800		13,400		18,200		21,800	
Air ΔT	°C	29.6	39.6	29.6	47.6	23.8	45.2	23.4	40.8	22.4	42.4	21.1	40.5
Static pressure	Pa	300		300		300		300		300		300	
Power Supply	V-Hz	400/3N~/50		400/3N~/50		400/3N~/50		400/3N~/50		400/3N~/50		400/3N~/50	
Motor Power Rating	kW	3		3		4		4		7.5		7.5	

5. USER INSTRUCTIONS

IMPORTANT: Carefully read safety warnings on pages 3 and 4 as they provide all basic safety information.

Users can only regulate controls on the room thermostat (not supplied as standard).

Controls on standard electrical switchboard are the following:

- one main switch (IG),
- one summer/0/winter switch (C1)
- signal lights (L1, L2, and L3).

In any type of heater, L1 light indicates that the unit is electrically wired. In heaters with three-phase power supply, a L2 light shows that thermal relay is operating, while the third light (L3) indicates whether the heater is heating or is running in summer mode for ventilation. In models 032N, 035N, and 060N-00A, C2 switch allows the setting of ventilation speed (two speeds available).

To start the heater, turn main IG switch to 1 (ON), verify that L1 is lighted, and place C1 switch on desired operating mode (summer/0/winter).

In summer mode, only fans work to assure air circulation in the room.

In winter mode, the burner is turned on and fans are started when the temperature set on the thermostat (FAN) is reached. During regular operation, the burner and the fans operate continuously without stopping.

When the set room temperature is reached, the room thermostat stops the burner, while the fan keeps working till air temperature decreases below the value set on TR (FAN) thermostat.

To keep the fan working even when air is cold, press the white button PUSH MAN on the double thermostat.

During cooling, fans can be restarted to cool down the air inside the heater, possibly warmed up by the exchanger.

The burner is restarted upon request by the room thermostat. If no room thermostat is installed, the heater can be turned off turning to 0 (zero) the C1 switch. This operation does not cut power supply and allows fans to complete the cooling cycle of the exchanger. Operations of any kind on the heater must be postponed until the unit has completely cooled down and can be disconnected from power supply.

Do not turn off the burner by powering off the heater since the exchanger, if not properly cooled, will last much less.

The heater is also equipped with a manual reset STB (LIMIT) safety thermostat which stops the burner in case of anomalous overheating. Use the RESET command to reset the heater.

If the problem is not solved and the heater is not reset after the RESET command has been repeatedly presses, turn the IG switch on 0 (OFF) and contact your authorized Service Centre.

The safety thermostat activation is very rare and indicates an ill functioning in the unit due to various possible reasons: excessive heat output caused by incorrect setting of the burner, insufficient air flow caused by grid and/or air filter obstruction, wrong duct size, wrong direction of fan rotation, etc.

In order to maximize heater reliability and minimize running costs, it is essential to periodically maintain (once a year, in general) the heater and the burner. **Only authorized personnel can provide maintenance.**

If unusual noise is heard during heater or burner operation, immediately ask for technical assistance.

Any time you call for assistance, either for repairing or maintenance purposes, ask the technicians to draw a dated and signed report, and include it in the relevant file. If the heater is going to be turned off for a long time, turn the IG main switch to 0 (OFF) and lock the valve on fuel pipe.

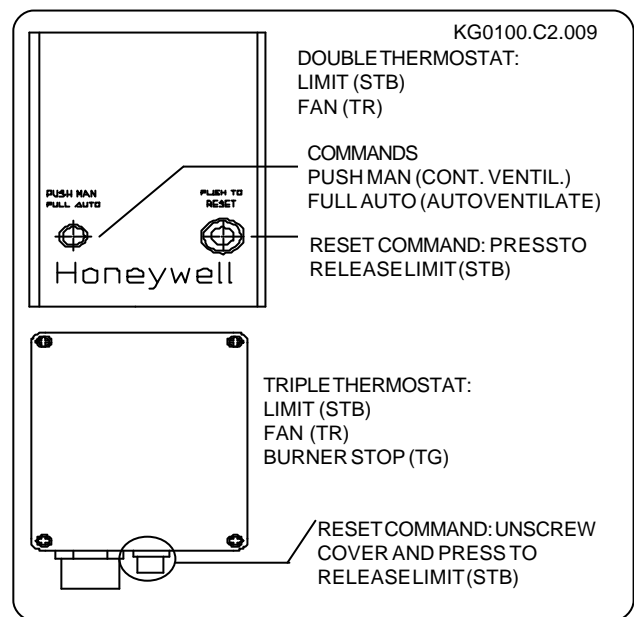

5.1 Burner failure

If the burner is damaged or does not work properly, do not attempt to repair it yourself. Unplug the unit from main supply and call for service.

The burner can only be repaired by qualified personnel from an authorized Service Centre. The non observance of these rules can compromise burner and heater safety.

FLOOR STANDING HEATERS PK-N

DOUBLE THERMOSTAT (STB/TR)
TRIPLE THERMOSTAT (STB/TR/TG)

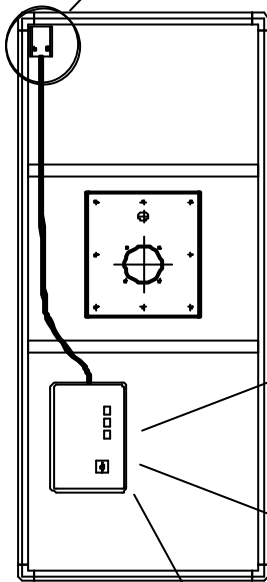

ELECTRICAL SWITCHBOARD FOR HEATERS
WITH 1 SINGLE-PHASE MOTOR
(FROM 032-00A TO 060N-00A)

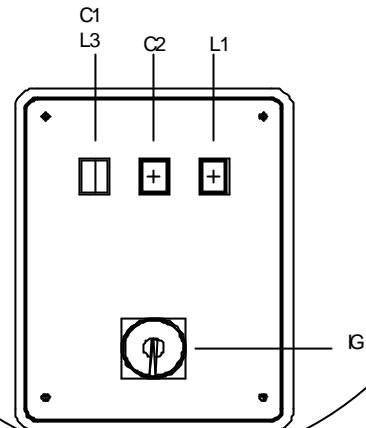

ELECTRICAL SWITCHBOARD FOR
HEATERS WITH 2 TRIPHASE MOTORS
(FROM 250N-00A TO 900N-20A)

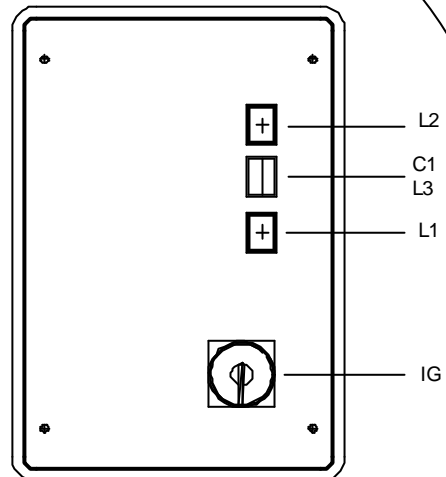
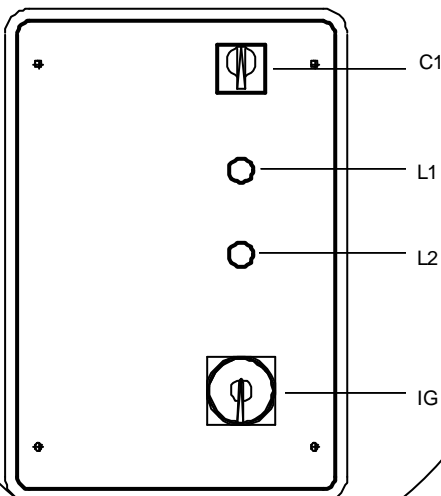

ELECTRICAL SWITCHBOARD FOR HEATERS
WITH 1 TRIPHASE MOTOR
(FROM 060N-10A TO 190N-20A)

LEGEND

- IG MAIN SWITCH
- C1 SUMMER/WINTER SWITCH
- C2 1ST/2ND SPEED SWITCH
- L1 LINE LIGHT
- L2 THERMAL RELAY LIGHT
- L3 WINTER OPERATION LIGHT

6. INSTRUCTIONS TO THE INSTALLER

6.1 Electrical Wiring

Electrical switchboards in PKA/E heaters, both single-phase and triphase, contain a door-lock main switch (IG) (see figure in this page).

Connect power supply directly to the switch using T1, T2, T3, and N (neutral) terminals for triphase line and T1 and N terminals for single-phase line.

Grounding wire (mandatory) must be connected to suitable terminal.

NOTE: To access terminals, unscrew the white cover on top of the switch. When you are finished, screw back protection cover.

IMPORTANT: Install a switch equipped with protection fuses before the heater switchboard, as required by the law.

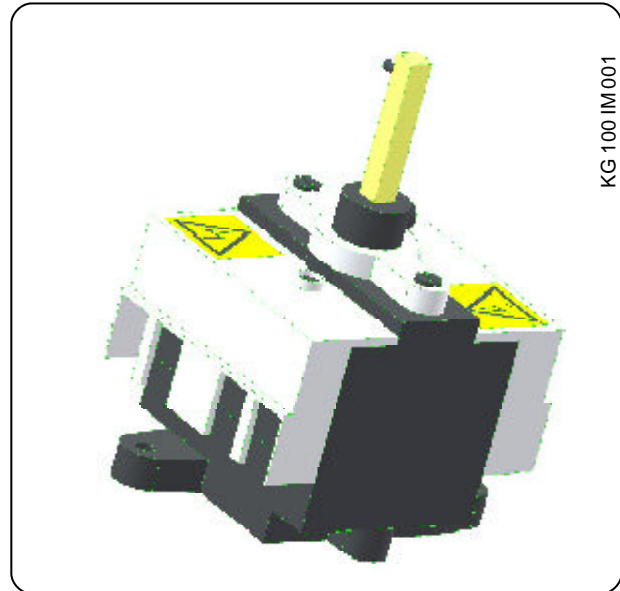

6.2 Burner Control Wiring

PKA/E heater switchboards contain terminals 1 to 4 for connecting burner controls.

Room Thermostat

Connect room thermostat to terminals 1 and 2. The burner is started only when room temperature decreases below set value.

Fire Stop Gates

Connect microswitch to terminals 3 and 4. When activated, they turn the burner off while the fan keeps working to cool down the exchanger using air emission gate. If the heater is installed outdoor and if the user requests that the fan is stopped with the burner, install a relay for powering off the heater.

Timer

Connect the timer to terminals 2 and 3. It starts up the burner at set times. A typical wiring scheme is shown in the figure in this page.

IMPORTANT: Preliminary removal of existing jumpers is required to connect different components, which must be connected in series.

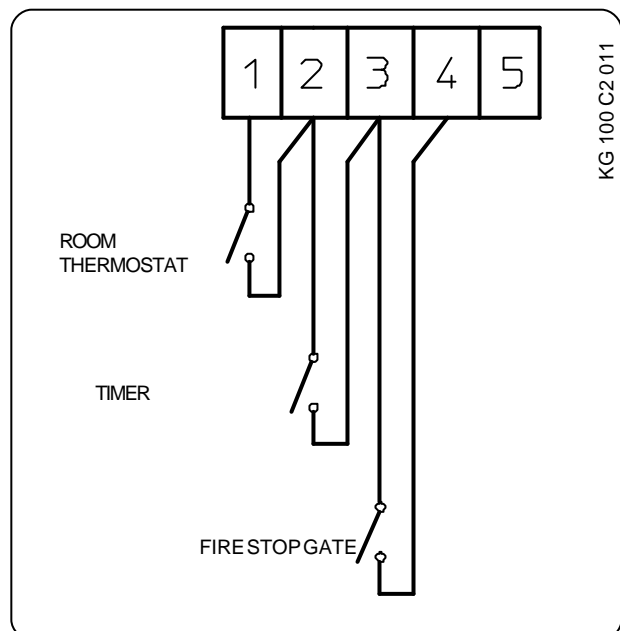

6.3 Burner Wiring

Connect the burner to suitable terminals in the switchboard as follows:

Models 032N to 190N (any versions but P0A)

Single-phase burner

230V supply from terminals L1-N.

Grounding from corresponding terminal.

Create a jumper for the thermostat series on the burner, if existing.

Controls on the heater are connected in series to burner supply.

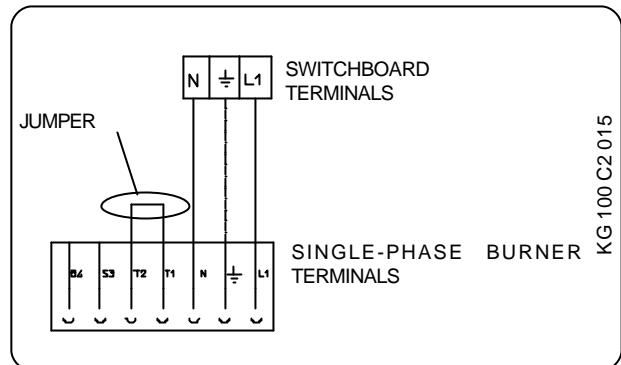

Models 250N to 900N (any versions but P0A)

Single-phase burner

230V supply from terminals L1-N.

Grounding from corresponding terminal.

Thermostat series from terminals T1 and T2.

Triphase burner

400V supply from terminals L1-L2-L3.

Neutral from terminal N.

Grounding from corresponding terminal.

Thermostat series from terminals T1 and T2.

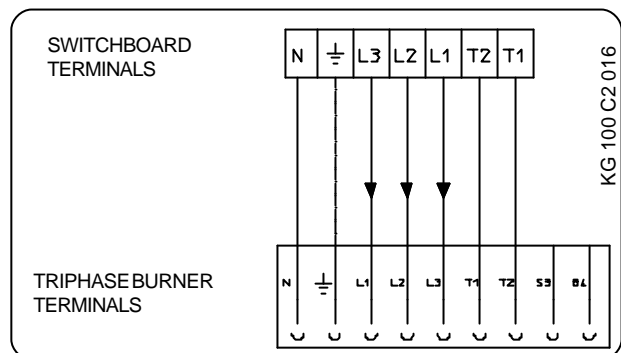

In models 250N to 900N it is mandatory to connect thermostat series from T1-T2 terminals in the heater to corresponding terminals in the burner.

DO NOT short-circuit burner terminals since this would exclude safety controls on the heater.

6.4 P0A Heater Wiring

In supplied P0A heaters all components are connected to the switchboard following the schemes shown in "Electrical Wiring" and "Burner controls" sections

Standard wired components are:

- Room thermostat TA.
- Fire stop gate MST1.
- Fire stop gate MST2.

Connect the timer, if present, in series to the room thermostat.

Note: The room thermostat, supplied with P0A heaters, is directly wired to auxiliary fuse FA.

P0A Burner Wiring (any models up to 320N)

Single-phase Burner

230V supply from terminals L1-N.

Grounding from corresponding terminal.

Create a jumper for the thermostat series on the burner, if existing.

Safety controls on the burner are connected in series to the burner power supply.

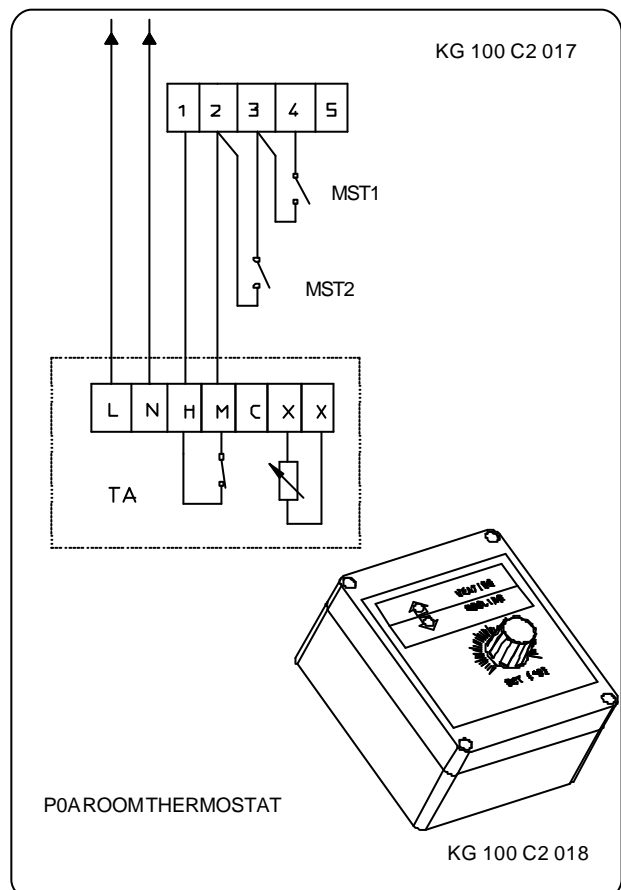

6.5 Thermostat Connection and Regulation

- Two types of thermostat groups are installed in PKA/E heaters:
- double thermostat group (TR+STB)
 - triple thermostat group (TR+TG+STB)

Heaters are certified with both thermostat groups. Triple thermostat group is presently installed on models up to PKA/E190N while higher models use double thermostat. STB thermostat (manual reset) stops the burner when the heat exchanger overheats. If this happens, reset the thermostat by pressing the release button, as explained in the user's section of this manual. TG thermostat is in series to STB thermostat and stops the burner when the temperature in the heater is higher than the set value. TR thermostat allows the fan to start only when air temperature reaches the set value. When the burner turns off, it allows the exchanger to cool down.

Double Thermostat

Adjust the thermostat using levers on the thermostat scale. Right-hand lever sets STB while central lever (to start the fan) and left-hand lever (to stop the fan) set FAN. The distance between the levers is the differential of FAN thermostat. Scale turns during operation to show the temperature measured by the thermostat.

Set the following temperatures:

- differential 30°C (stops the fan during cooling)
- TR (FAN) 45°C (starts the fan during heating)
- STB (LIMIT) 90°C for 032N-035N-060N
100°C for 100N-120N-140N-250N-320N
120°C for PK190-420-550-700-900

Triple thermostat

The following temperature values are set in the three thermostats assembled in the box:

- 40°C for TR
- 90°C for TG
- 100°C (fixed) for STB

To set different values for TR and TG thermostats, turn suitable screws.

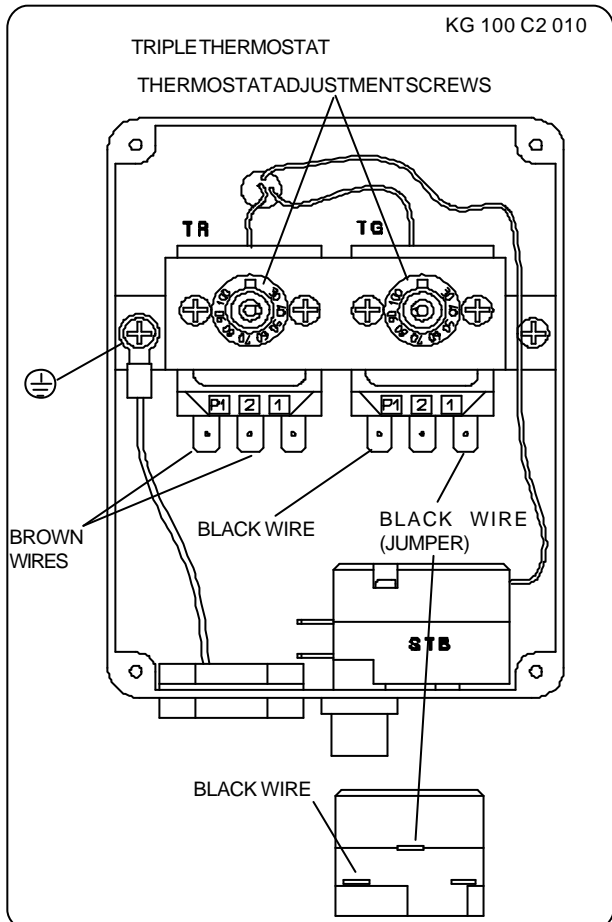
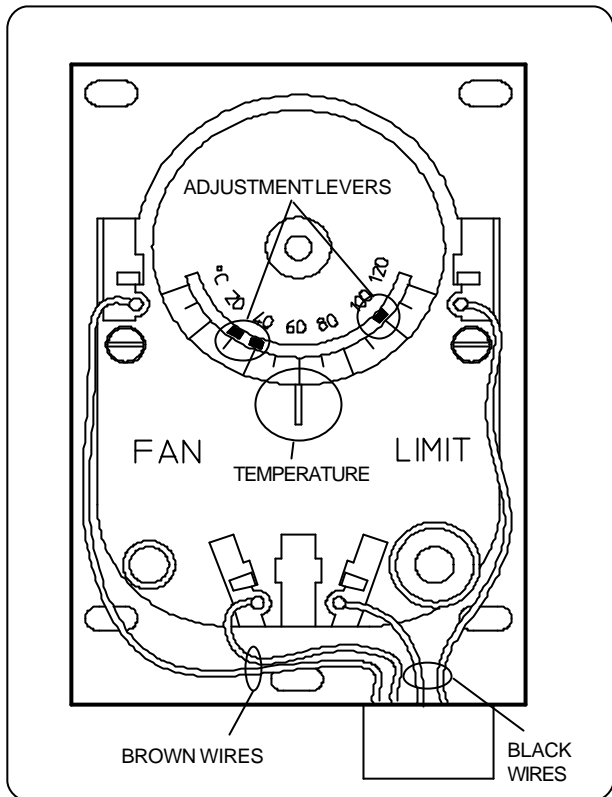

6.6 Burner Nozzle and Plate

Burner nozzle length must fall within the range indicated in column "X" of the table below.

Important: If nozzle is shorter than minimum "X" value, the heat exchanger could be damaged and the warranty cancelled.

The "ØT" value indicates maximum nozzle diameter for the

relevant type of burner. If the installed nozzle is longer, the heat exchanger must be changed at an extra cost.

If a Low NOx burner is going to be used (flue re-circulation outside combustion head), contact Nordair-Niche Service.

Series heaters are supplied with standard burner plates whose dimensions are shown in the table below. If holes in standard plate do not suit matching burner, different holes can be drilled in the plate upon request by specifying burner type and model.

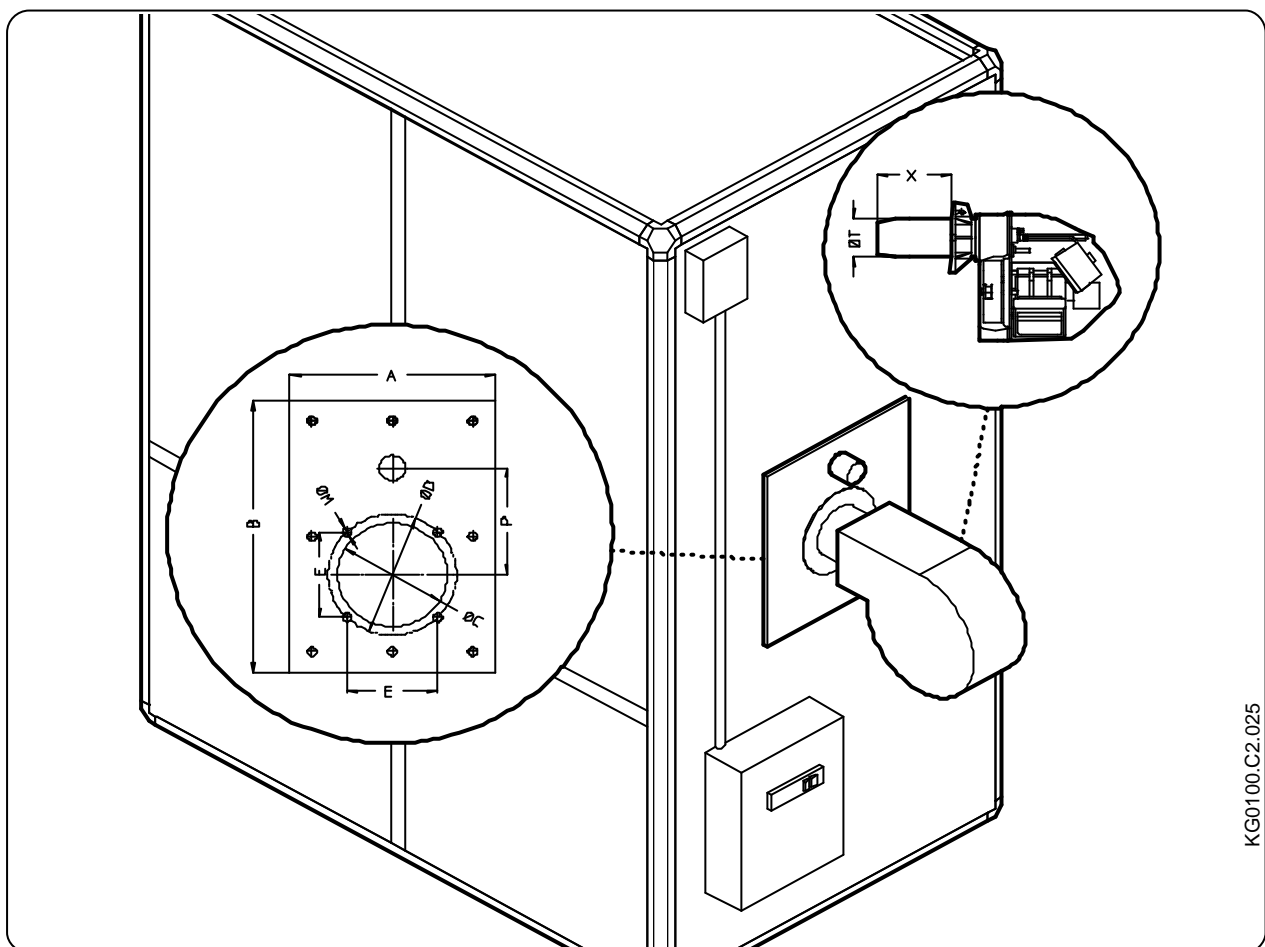

KG0100.C2.025

Type	X		ØT	P	A	B	ØC	ØD	ØM	E
	min [mm]	max [mm]	max [mm]							
032-035	150	220	135	150	270	382	115	170	M8	120
060-100-120	150	220	135	150	270	382	133	170	M8	120
140	270	350	190	175	414	454	140	175	M8	124
190-250	270	350	190	175	414	454	160	223	M8	158
320	270	350	230	230	464	484	160	223	M8	158
420-550	270	350	230	230	464	484	190	269	M8	190
700-900	350	480	290	280	560	590	210	325	M10	230

KG0100.ET.011

6.7 Optional Parts

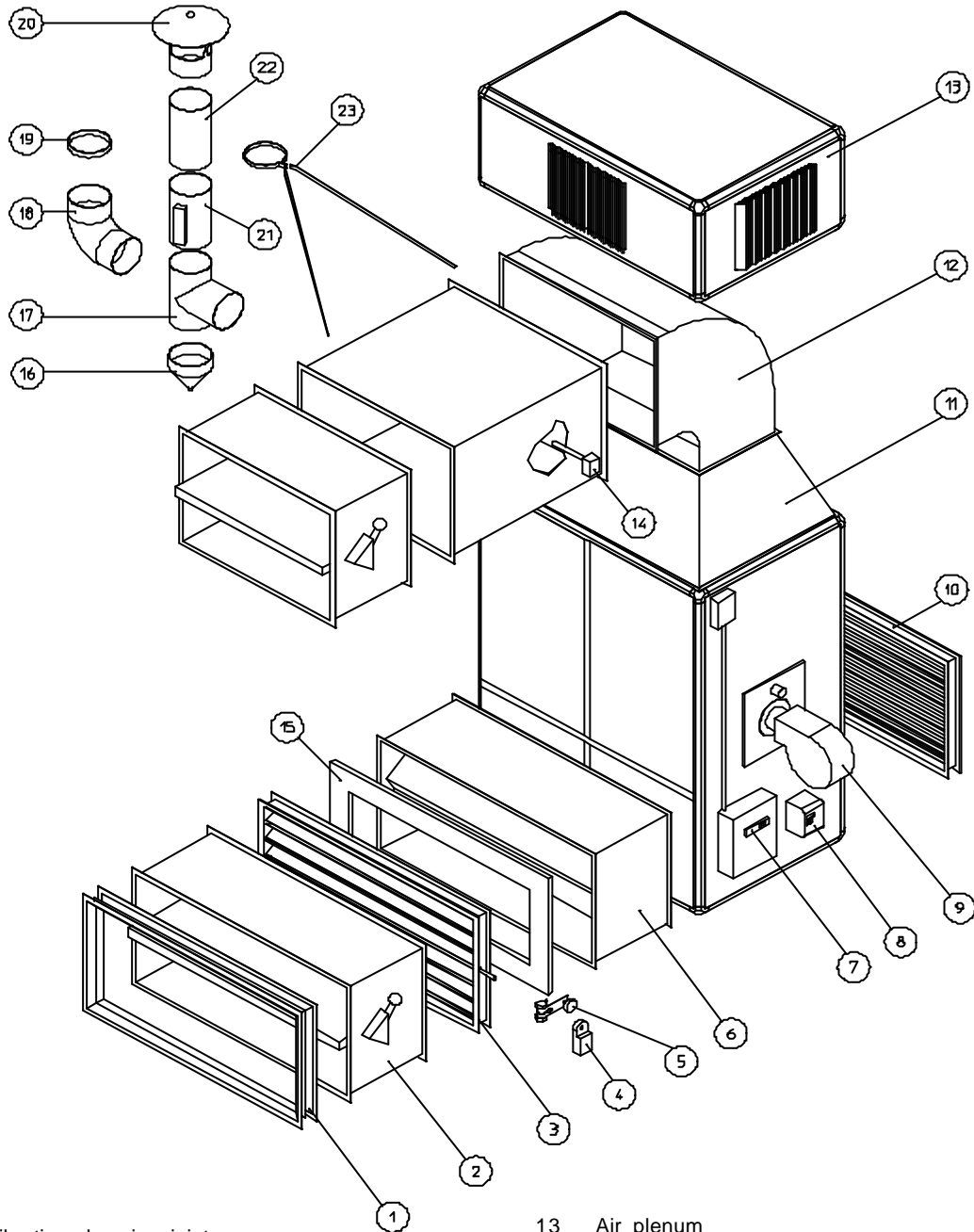

List

- | | | | |
|----|--|----|---|
| 1 | Vibration damping joint | 13 | Air plenum |
| 2 | Fire stop gate | 14 | Duct temperature probe |
| 3 | Regulation grid | 15 | Grid junction kit |
| 4 | Servomotor for grid | 16 | Condensate collector |
| 5 | Manual grid control | 17 | 90° T pipe |
| 6 | Filters | 18 | 90° bend |
| 7 | Two-phase burner control | 19 | Chimney ring |
| 8 | Control inverter for air flow/air pressure | 20 | Chimney cover |
| 9 | Burner | 21 | Flue inspection module |
| 10 | Rain protection grid | 22 | 1-meter straight pipe |
| 11 | Duct adapter (not included) | 23 | Tie-wire kit for mounting the chimney on the heater |
| 12 | Duct bend (not included) | 24 | Room temperature probe (not shown) |

KG0100.C2.022

Air Intake Accessories

The air filter, if required, is mounted directly to the heater frame, without adapters, following instructions in relevant paragraph.

The motor-driven air grid must be installed on the filter or heater using an adjustment kit.

The fire stop gate, if required, must be directly assembled on regulation grid. In some cases, as explained in relevant paragraph, a fitting (included) must be installed to allow fan rotation.

Fire stop gate requires an adjustment kit for direct installation on heater frame or air filter, too.

Install the vibration damping joint directly on the fire stop grid or on the air regulation grid.

If air is sucked in from outdoor, a rain protection grid with bird-stop screen is available. To mount the grid on heater frame, an adjustment kit is required. The regulation grid can be mounted in between the adjustment kit and the rain protection grid.

Air Outlet Accessories

The air plenum must be put over the heater without fixing it. See the relevant paragraph for information on number, dimensions and position of louvers.

If a duct system is to be used, the installer will take care of installing a bend or a junction to available ducts.

The table in the following page shows suggested bend/junction dimensions in order to assure a speed of 8-9 m/s in outlet duct. Comply to these dimensions if the user requests that fire-stop gates (available at Nordair-Niche) are installed on air inlet.

Regulation Accessories

Air regulation grid

The air grid supplied can be motor driven but no motor is enclosed. Available kits are as follows:

- manual operation kit;
- servomotor for on/off operation (230V);
- servomotor for modular operation 0-10 Vdc (24V).

See relevant paragraph for available models and codes.

Air temperature regulation

A digital electronic control is installed on the front panel of the electrical switchboard to monitor air temperature.

This control is equipped with a probe installed either in the room or in ducts, according to equipment type.

This control can be used only if a two-phase burner is installed.

Variable Air Flow

Motors with two polarities

Specific installations which require two different air flow values can use heaters with two-polarity motors having 4/6 or 4/8

poles, as required.

Pros and cons of motors with two polarities are the following:

- air flows are directly proportional to pole number ratio ($V_2=V_1*(n_2/n_1)$)
- prevalences are proportional to the square of pole number ratio ($H_{T2}=H_{T1}*(n_2/n_1)^2$)
- power absorbed is proportional to the cube of pole number ratio ($P_{V2}=P_{V1}*(n_2/n_1)^3$)

This implies high absorption levels by motors and structural changes to the heater frame (where necessary).

Inverter

Upon request, the heater can be equipped with a digital frequency static inverter to control and set fan operation and/or provide multiple rotation speeds.

This device assures the following advantages:

- Variable air flow: continuous speed regulation from a minimum to a maximum, depending on the input of a temperature or pressure probe, or other devices.
- In pressurized coverings: optimal internal pressure with the help of a wind speed detector, and reduces considerably power consumption.
- Allows up to seven set speeds.
- In installations where loss of pressure is unknown or difficult to calculate, it allows precise setting of the air flow during installation.
- Single-phase power supply of triphase units (up to 4kW motors).

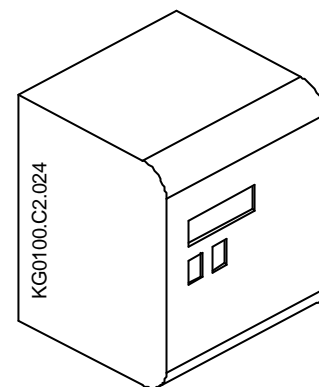

Chimney Accessories

Parts supplied for flue discharge are made of single-sheet stainless steel AISI316 and are suitable for indoor or outdoor installation.

Air Filter

Air filters in the price list allow air inlet from one side only. If air inlet must be from both sides in case of nonstandard installation, contact Nordair-Niche to have correct sizes .

Standard filter is made of modacrylic fibre, belongs to fire resistance class 1 (one), and can be used continuously up to max temperature of 80°C. Its weight efficiency is 84% (ASHRAE), which corresponds to class G3 (formerly EU3).

To regenerate filters, clean them as follows:

- in case of dry dust, shake, vacuum clean or blow the filter with compressed air. As an alternative, wash it with an air jet;
- in case of greasy dust, soak the filter into lukewarm water with mild detergent. Do not bush nor wring out filtering pads.

Filter loss (ΔP) is referred to clean filters and must be deducted from static pressure of the heater. Maximum loss of dirty filter can reach 400 Pa and would jeopardize heater operation. It is recommended to use a pressure switch which stops the heater whenever the set value is reached.

To clean the filter, remove it by unscrewing its fixing screws. Before doing this, make sure the heater is disconnected from power supply.

Three filter models are used, as shown in pictures in this page. To install the filter, remove the air intake screen on the heater. When installing aluminium-framed filter (fig. III), use supplied supports to fasten the filter to the frame.

Then, seal fissures with silicone. This is particularly necessary if the unit is installed outdoor.

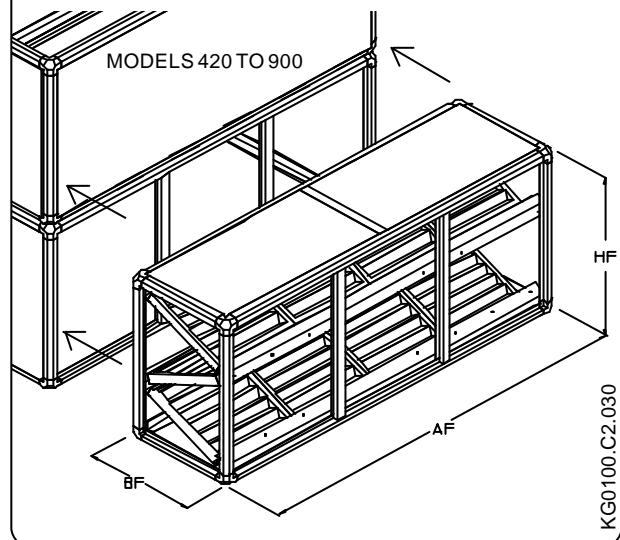
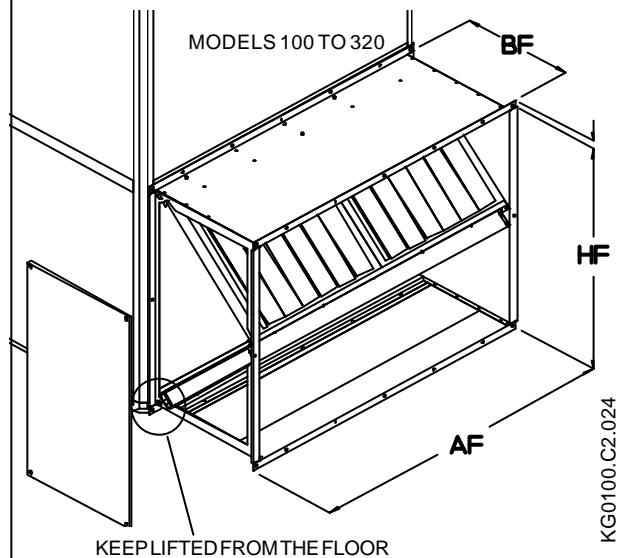
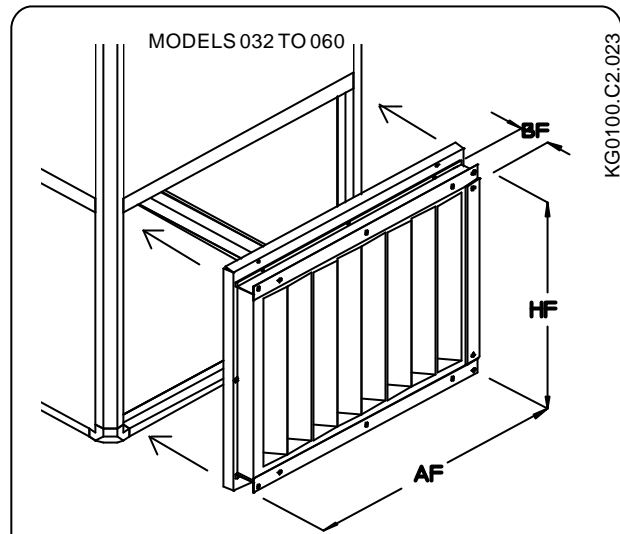

KG0100.ET.012

Type	Dimensions			D P Pa
	AF [mm]	HF [mm]	BF [mm]	
PKA032N-035N	625	500	60	47
PKA060N	800	625	60	61
PKA100N-120N	1070	850	420	35
PKA140N	1300	850	420	33
PKA190N	1430	850	420	75
PKA250N	1720	850	420	76
PKA320N	1930	850	420	81
PKA420N	2170	1000	630	57
PKA550N	2600	1290	630	53
PKA700N	2950	1290	720	63
PKA900N	3550	1420	720	67

FLOOR STANDING HEATERS PK-N

Vibration damping joint

If correctly installed on air inlet or outlet, the vibration damping joint absorbs vibrations produced by air ducts and therefore prevents their noisy transmission.

These joints are made of neoprene and metal and resist to temperatures of 100°C max. Their fire class is M2. The frame (mounting flange) is made of zincate steel.

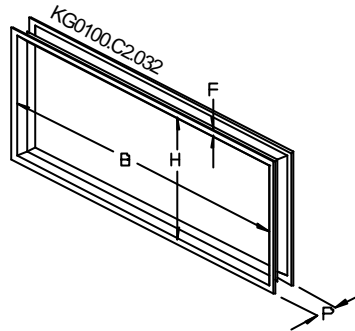

Type	Code	B	H	P	F
		[mm]	[mm]	[mm]	[mm]
32-35	G09887	450	410	150	25
60	G09907	600	510	150	25
100-120	G09917	800	610	150	25
140	G09927	1000	610	150	25
190	G09937	1200	710	150	25
250	G09947	1400	710	150	25
320	G09957	1500	810	150	25
420	G09967	1900	910	150	25
550	G09977	2000	1210	150	25
700	G09987	2600	2010	150	25
900	G09997	3000	1360	150	25

KG0100.ET.015

Regulation grid and motor-driven controls

Grids are made of zincate steel, are moved specularly thanks to lever systems and their control shaft (Ø 12) sticks out by 100 mm.

Use the grid joint kit to mount the grid on the heater or filter frame.

In addition to grids, manual controls or servomotors for motor-driven controls can be supplied upon request.

Two types of manual controls are available, depending on grid depth (100 or 150mm).

Servomotors differ according to operation (on-off or modulation) and available torque.

Type	Code	B	H	P	F
		[mm]	[mm]	[mm]	[mm]
32-35	G09884	450	410	100	40
60	G09904	600	510	100	40
100-120	G09914	800	610	100	40
140	G09924	1000	610	100	40
190	G09934	1200	710	100	40
250	G09944	1400	710	100	40
320	G09954	1500	810	100	40
420	G09964	1900	910	150	40
550	G09974	2000	1210	150	40
700	G09984	2600	1210	150	40
900	G09994	3000	1360	150	40

KG0100.ET.017

Type	Code	Description
032-320	G09901	Manual grid control P. 100mm
032-320	G07240	Modulating servomotor 0-10Vdc - 24Vac - 8Nm supply
032-320	G06642	ON-OFF servomotor - 230Vac - 8Nm supply
420-900	G09902	Manual grid control P. 150mm
420-900	G09980	Modulating servomotor 0-10Vdc - 24Vac - 18Nm supply
420-900	G07208	ON-OFF servomotor - 230Vac - 18Nm supply

KG0100.ET.019

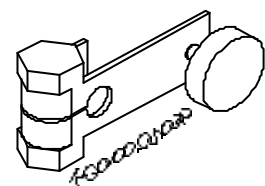
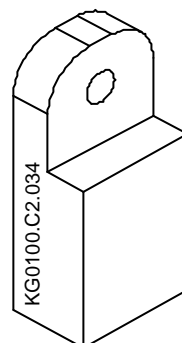
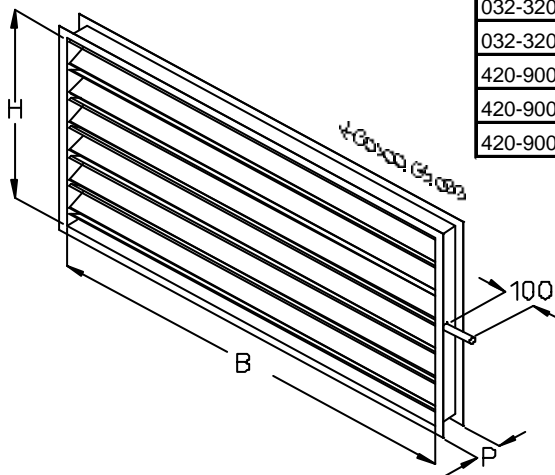

Rain protection grids

They are made of zincate steel and include a bird-stop screen. Mount them directly on regulation grids. To mount them on heater frame or on the filter, use the grid adapting kit.

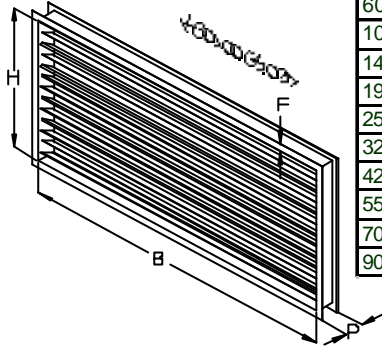

Type	Code	B	H	P	F
32-35	G09885	450	410	50	40
60	G09905	600	510	50	40
100-120	G09915	800	610	50	40
140	G09925	1000	610	50	40
190	G09935	1200	710	50	40
250	G09955	1400	710	50	40
320	G09955	1500	810	50	40
420	G09965	1900	910	50	40
550	G09975	2000	1210	50	40
700	G09985	2600	1210	85	40
900	G09995	3000	1360	85	40

KG0100.ET.018

Fire stop gates

Fire stop gates supplied are REI120 certified. Outer casing is made of 15/10mm zincate steel and plasterboard shutter is 48mm thick. A lever for manual reset, a fuse set at 72°C, a thermal cutout and a microswitch are provided. Fire resistance class is REI120.

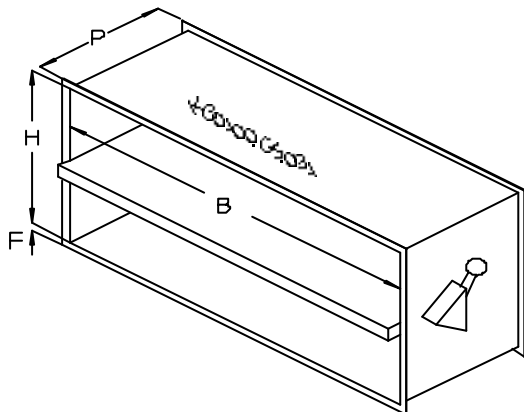

AIR INLET					
Type	Code	B	H	P	F
32-35	G09886	450	400	500	40
60	G09906	600	500	500	40
100-120	G09916	800	600	500	40
140	G09926	1000	600	500	40
190	G09936	1200	700	500	40
250	G09946	1400	700	500	40
320	G09956	1500	800	500	40

IN MANDATA					
Type	Code	B	H	P	F
32-35-60	G09886	450	400	500	40
100-120	G09906	600	500	500	40
140	G09916	800	600	500	40
190	G09926	1000	600	500	40
250	G09936	1200	700	500	40
320	G09946	1400	700	500	40
420	G09956	1500	800	500	40

KG0100.ET.016

Duct Bend

This section contains instructions to connect PKA and PKE heaters to our air outlet grids. Dimensions shown are referred to an air speed range of 8-9 m/s in the ducts. Shapes and dimensions can obviously differ from the ones shown. The table contains internal dimensions.

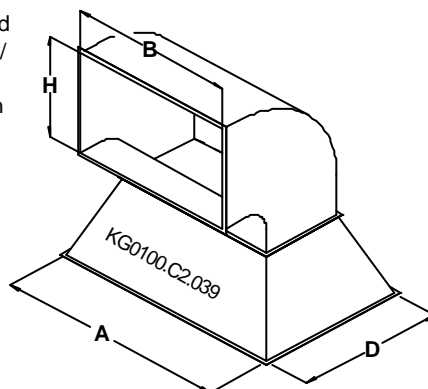

Type	Heater		Duct	
	A	D	B	H
PKA032N-035N	670	450	450	400
PKA060N	915	620	450	400
PKA100N-120N	1020	720	600	500
PKA140N	1250	840	800	600
PKA190N	1380	980	1000	600
PKA250N	1670	1060	1200	700
PKA320N	1880	1060	1400	700
PKA420N	2070	1240	1500	800

KG0100.ET.020

FLOOR STANDING HEATERS PK-N

Air Plenum

Air plenum is supplied with double deflection louvers, suitable both for industrial and commercial environments. Louvers assure high ranges of air flow and low pressure drop. They are made of aluminium (for models 032-035-060) and zincate steel (for remaining models). The distance between louvers is 25 or 50mm.

Standard plenums blow air on two short sides and one long side. Customized plenums can blow air on two long sides and one short side.

The tables below contain following columns:

- Code: it's the number to be quoted when ordering.
- Short side: number and dimensions of short side louvers.
- Long side: number and dimensions of long side louvers.
- H: total height of the plenum. Length and width are the same as the corresponding heater's.
- VK: outlet speed of the air when fin canting equals 0° (zero).

If canting is 22°, increase VK value by 16%, if canting is 45°, increase VK value by 30%. (Canting indicates horizontal angle for air blowing.)

- Range: distance (in meters) at which air is blown. The value refers to a residual velocity of 0,3 m/s. If canting angle is 22°, multiply range by 0,70; if angle is 45°, multiply by 0,52.

- ΔP: pressure drop at VK outlet speed (canting angle equal to 0°).

STANDARD - 2 SHORT SIDES - 1 LONG SIDE

PLENUM code	Short Side		Long Side		H mm	VK m/s	ir m	Rang Pa
	No.	Louver size	No.	Louver size				
PLXPKA035N	2	300x160	1	500x160	330	6.7	19	28
PLXPKA060N	2	500x160	1	600x160	330	7.9	22	41
PLXPKA100N	2	400x200	1	800x200	380	9.5	26	60
PLXPKA140N	2	500x300	1	800x300	480	7.7	21	38
PLXPKA190N	2	600x300	1	800x300	480	9.2	25	56
PLXPKA250N	2	600x300	2	600x300	480	9.9	27	66
PLXPKA320N	2	800x300	2	800x300	480	9.3	25	58
PLXPKA420N	2	800x400	2	800x400	630	9.1	25	55
PLXPKA550N	2	1000x400	3	600x400	630	10	27	68
PLXPKA700N	4	600x400	4	600x400	630	10.7	29	79
PLXPKA900N	4	800x400	4	600x400	630	11.8	32	98

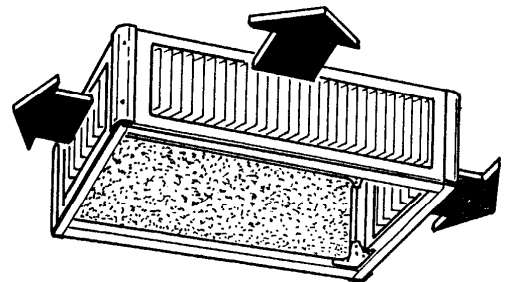

UPON REQUEST - 1 SHORT SIDE - 2 LONG SIDES

PLENUM code	Short Side		Long Side		H mm	VK m/s	ir m	Rang Pa
	No.	Louver size	No.	Louver size				
PLXPKA035N-1	1	300x160	2	500x160	330	5.6	16	19
PLXPKA060N-1	1	500x160	2	600x160	330	7.5	21	36
PLXPKA100N-1	1	400x200	2	800x200	380	7.5	21	36
PLXPKA140N-1	1	500x300	2	800x300	480	6.5	18	26
PLXPKA190N-1	1	600x300	2	800x300	480	8.3	23	45
PLXPKA250N-1	1	600x300	4	600x300	480	7.9	22	40
PLXPKA320N-1	1	800x300	4	800x300	480	7.5	21	36
PLXPKA420N-1	1	800x400	4	800x400	630	7.2	20	33
PLXPKA550N-1	1	1000x400	4	600x400	630	8.3	23	45
PLXPKA700N-1	2	600x400	8	600x400	630	8.6	24	48
PLXPKA900N-1	2	600x400	8	800x400	630	8.7	24	50

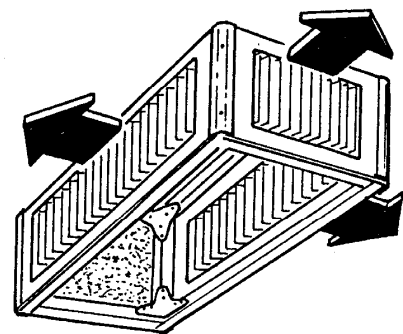

KG0100.ET.022

Chimney Components

Supplied chimneys are made of one-sheet stainless steel AISI 316.

Fasten components by rotating their groove-and-tongue ends. Rings are required only for chimneys longer than two meters. Silicone rubber seals are provided.

Running temperature is 400°C in vacuum dry or wet working conditions and 250°C in pressurized working conditions. Chimneys can work both in vacuum or in pressurized conditions. Maximum pressure is 1,000 Pa. Flue inspection module is 300 mm long and includes a thermometer.

Straight chimney (1 meter)

Model	Code	Ø [mm]
032N-035N	G04052-120	120
060N	G04052-150	150
100N-140N	G04052-180	180
190N-320N	G04052-250	250
420N-550N	G04052-300	300
700N	G04052-350	350
900N	G04052-400	400

Chimney ring

Model	Code	Ø [mm]
032N-035N	G04055-120	120
060N	G04055-150	150
100N-140N	G04055-180	180
190N-320N	G04055-250	250
420N-550N	G04055-300	300
700N	G04055-350	350
900N	G04055-400	400

90° bend

Model	Code	Ø [mm]
032N-035N	G04054-120	120
060N	G04054-150	150
100N-140N	G04054-180	180
190N-320N	G04054-250	250
420N-550N	G04054-300	300
700N	G04054-350	350
900N	G04054-400	400

T joint

Model	Code	Ø [mm]
032N-035N	G04050-120	120
060N	G04050-150	150
100N-140N	G04050-180	180
190N-320N	G04050-250	250
420N-550N	G04050-300	300
700N	G04050-350	350
900N	G04050-400	400

Condensate collector

Model	Code	Ø [mm]
032N-035N	G04051-120	120
060N	G04051-150	150
100N-140N	G04051-180	180
190N-320N	G04051-250	250
420N-550N	G04051-300	300
700N	G04051-350	350
900N	G04051-400	400

Conic rain shelter

Model	Code	Ø [mm]
032N-035N	G04053-120	120
060N	G04053-150	150
100N-140N	G04053-180	180
190N-320N	G04053-250	250
420N-550N	G04053-300	300
700N	G04053-350	350
900N	G04053-400	400

Tie-wire kit

Model	Code	Ø [mm]
032N-035N	G01822-120	120
060N	G01822-150	150
100N-140N	G01822-180	180
190N-320N	G01822-250	250
420N-550N	G01822-300	300

Flue inspection module

Model	Code	Ø [mm]
032N-035N	G04057-120	120
060N	G04057-150	150
100N-140N	G04057-180	180
190N-320N	G04057-250	250
420N-550N	G04057-300	300
700N	G04057-350	350
900N	G04057-400	400

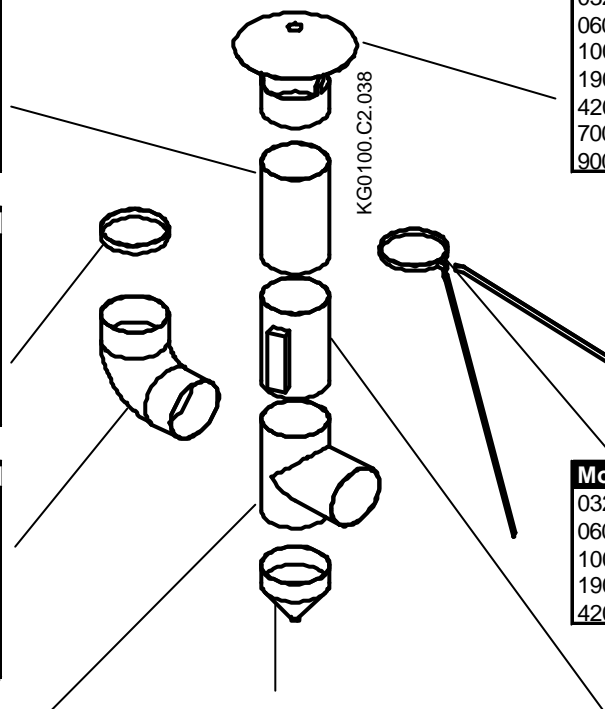

FLOOR STANDING HEATERS PK-N



7. INSTRUCTIONS TO THE SERVICE CENTRE

7.1 Electrical Components and Wiring Diagrams

Every switchboard has a protection level of IP54. PKE heaters components are the same as corresponding PKA heaters. Information in the following tables pertain to standard products.

KG0100.ET.0009

Heater Type	Electr. Wiring	Power Supply	Motor No.	Output [kW]	Power Absorbed [kW]	Current Absorbed [A]	Aux. Fuses [A]	Burner Fuses [A]	Motor Fuses [A]	Therm Relay [A]			
PKA032N-00A	JP0081	230V 50 Hz	1	0,245	0,400	3	6 gG						
PKA032N-10A				0,5	0,800	5,5	8 gG						
PKA035N-00A				0,245	0,400	3	6 gG						
PKA035N-10A				0,5	0,800	5,5	8 gG						
PKA060N-00A	JP0082	400V 50Hz	1	0,75	0,960	5,5	10 gG						
PKA060N-10A				11	1,47	2,85	6 gG	4 aM	2,0-3,3				
PKA060N-20A				15	1,97	3,7	6 gG	6 aM	3,0-5,0				
PKA100N-00A				11	1,47	2,85	6 gG	4 aM	2,0-3,3				
PKA100N-10A				15	1,97	3,7	6 gG	6 aM	3,0-5,0				
PKA100N-20A				22	2,77	5,3	6 gG	8 aM	4,5-7,5				
PKA120N-00A				11	1,47	2,85	6 gG	4 aM	2,0-3,3				
PKA120N-10A				15	1,97	3,7	6 gG	6 aM	3,0-5,0				
PKA120N-20A				22	2,77	5,3	6 gG	8 aM	4,5-7,5				
PKA140N-00A PKA140N-10A				3	3,72	7	6 gG	10 aM	4,5-7,5				
PKA140N-20A				4	4,86	9	6 gG	12 aM	6,0-10				
PKA190N-00A PKA190N-10A				3	3,72	7	6 gG	10 aM	4,5-7,5				
PKA190N-20A				4	4,86	9	6 gG	12 aM	6,0-10				
PKA060N-190N SPECIALI				5,5	6,8	11,9	6 gG	16 aM	9,0-15				
PKA250N-00A PKA250N-10A				JP0083	400V 50Hz	2	2,2	5,54	10,6	2 gG	10 gG	10 aM	4,5-7,5
PKA250N-20A							3	7,44	14	2 gG	10 gG	10 aM	6-10
PKA320N-00A	2,2	5,54	10,6				2 gG	10 gG	10 aM	4,5-7,5			
PKA320N-10A	3	7,44	14				2 gG	10 gG	10 aM	4,5-7,5			
PKA320N-20A PKA420N-00A	JP0084*	400V 50Hz	2	4	9,72	18	2 gG	10 gG	16 aM	6,0-10			
PKA420N-10A				5,5	8	23,8	2 gG	10 gG	16 aM	6,0-10			
PKA420N-20A	JP0083	400V 50Hz	2	7,5	17,5	32	2 gG	10 gG	20 aM	6,0-10			
PKA550N-00A				3	7,44	14	2 gG	10 gG	10 aM	4,5-7,5			
PKA550N-10A	JP0084*	400V 50Hz	2	4	9,72	18	2 gG	10 gG	16 aM	6,0-10			
PKA550N-20A				5,5	8	23,8	2 gG	10 gG	16 aM	6,0-10			
PKA700N-00A	JP0083	400V 50Hz	2	4	9,72	18	2 gG	10 gG	16 aM	6,0-10			
PKA700N-10A				5,5	8	23,8	2 gG	10 gG	16 aM	6,0-10			
PKA700N-20A	JP0084*	400V 50Hz	2	7,5	17,5	32	2 gG	10 gG	20 aM	6,0-10			
PKA900N-00A				7,5	17,5	32	2 gG	10 gG	20 aM	6,0-10			
PKA900N-10A	JP0084*	400V 50Hz	2	9,2	21,74	38	2 gG	10 gG	25 aM	9,0-15,0			
PKA900N-20A				11	25,6	45	2 gG	10 gG	25 aM	9,0-15,0			

* Star/delta motor startup

P0A Components

Heater Type	Electr. Wiring	Power Supply	Motor No.	Output [kW]	Power Absorbed [kW]	Current Absorbed [A]	Aux. Fuses [A]	Burner Fuses [A]	Motor Fuses [A]	Therm Relay [A]
PKE100N-P0A	JP0082	400V 50Hz	1	3	3,720	7	6 gG		10aM	4,5-7,5
PKE120N-P0A				4	4,860	9	12aM		6,0-10	
PKE140N-P0A				7,50	10,000	17,5	2gG	10gG	25aM	14-23
PKE190N-P0A										
PKE250N-P0A										
PKE320N-P0A										

fine

Diagram JP0081

Characteristics: 1 230V single-phase motor, 2 speeds, direct start-up, single-phase burner

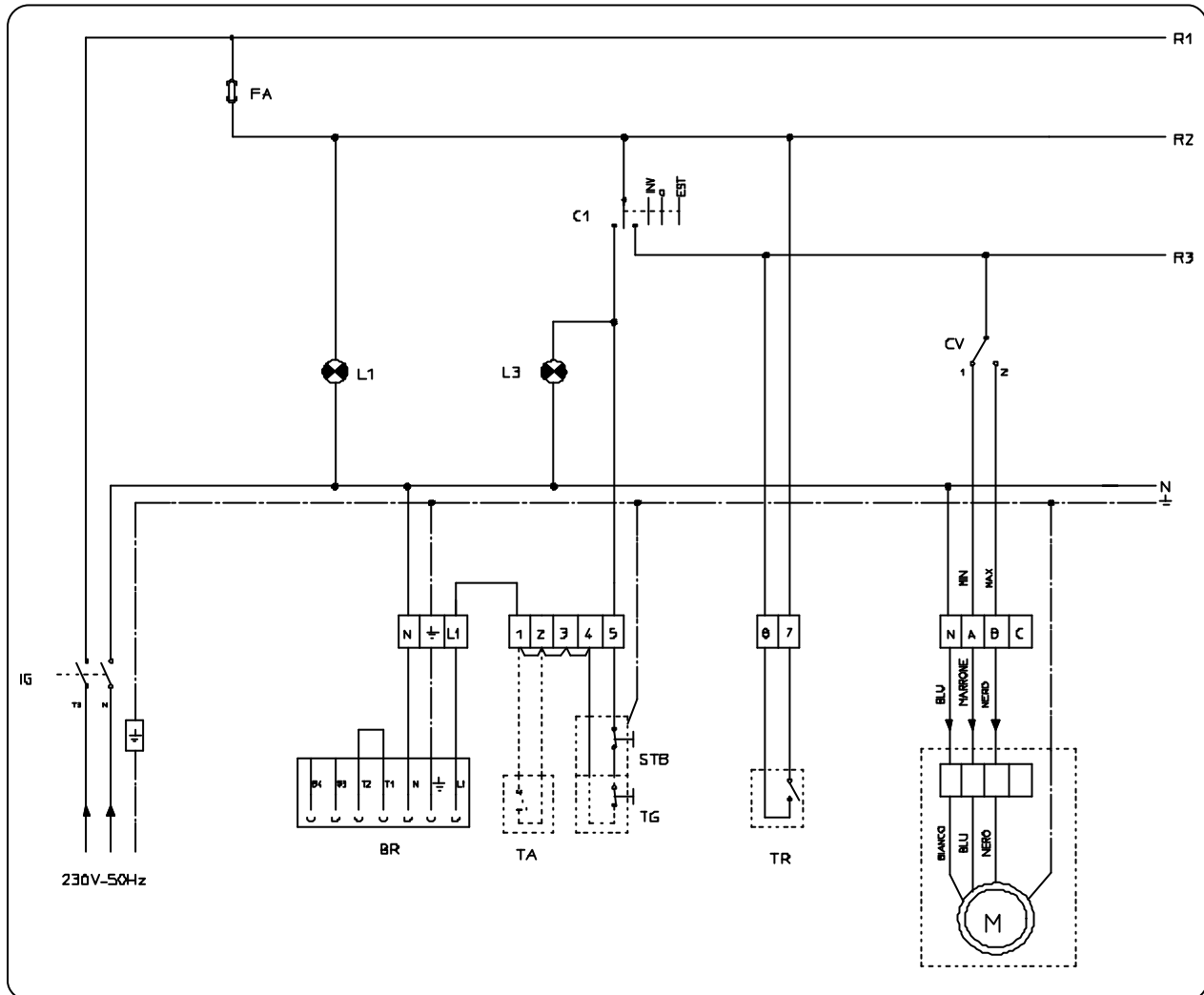

LEGEND

- M fan 230V/50Hz single-phase motor
- BR burner
- IG main switch
- C1 summer/winter switch
- STB limit thermostat
- TR fan thermostat
- TG burner stop thermostat
- FA fuse
- L1 line light
- L3 winter operation light
- CV fan speed switch
- TA room thermostat (optional)

KG100 C2 019

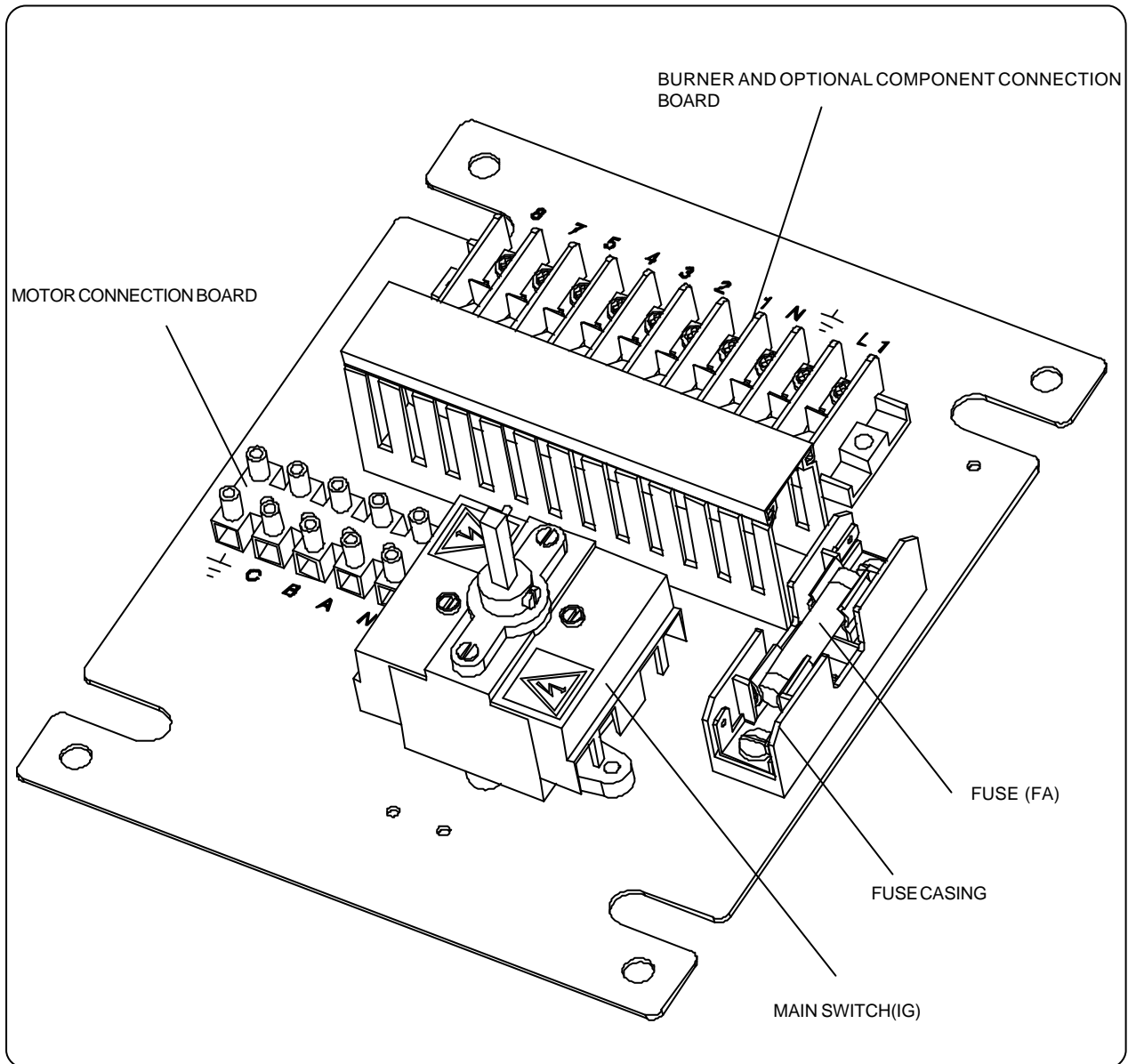
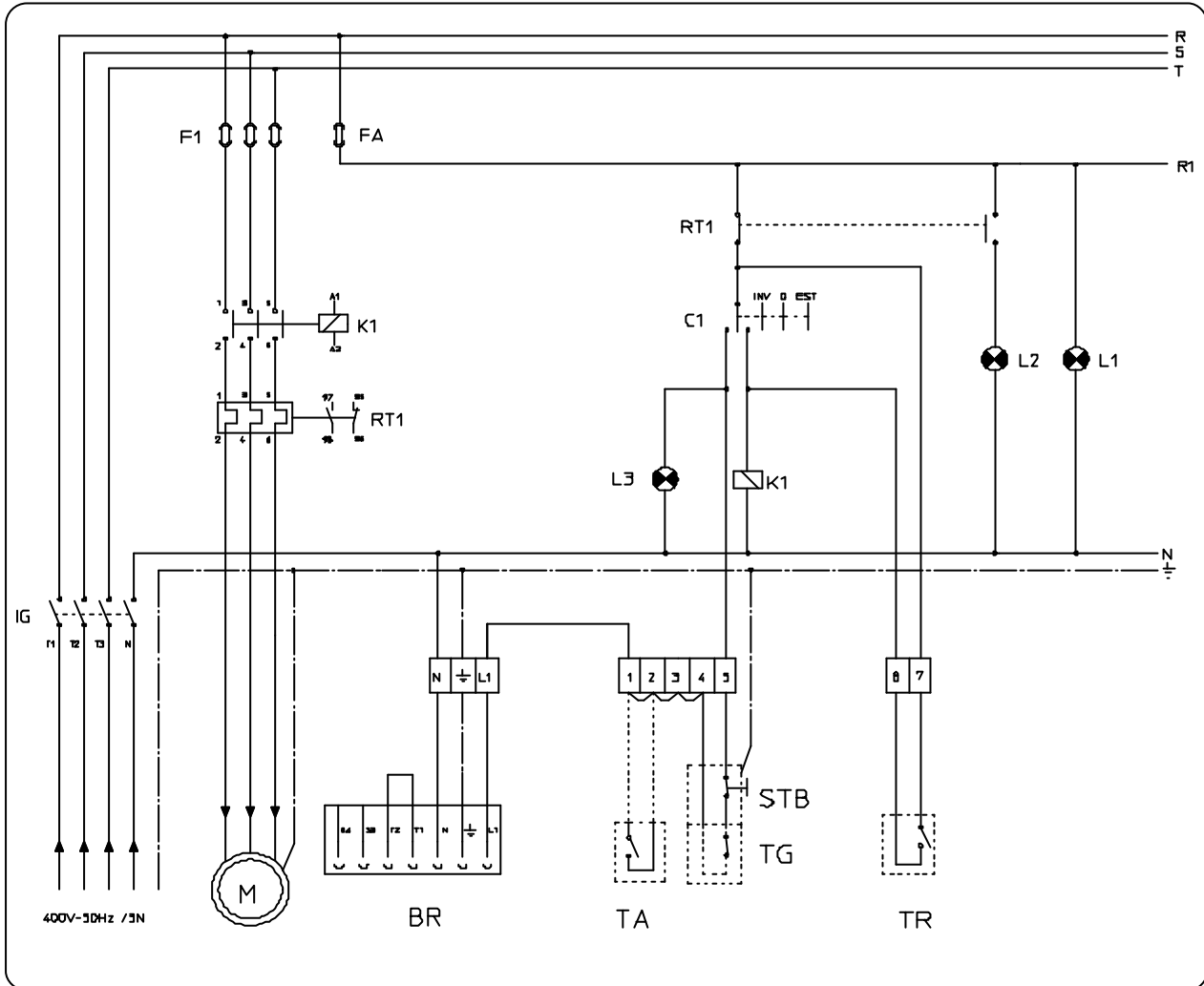

Diagram JP0082

Characteristics: 1 400V triphase motor, direct start-up, single-phase burner



LEGEND

- M fan 400V/50Hz triphase motor
- BR burner
- IG main switch
- C1 summer/0/winter switch
- STB limit thermostat
- TR fan thermostat
- TG burner stop thermostat
- FA auxiliary fuses
- F1 motor fuses
- L1 line light
- L2 thermal relay light
- L3 winter operation light
- K1 contactor (230V coil)
- RT1 motor thermal relay
- TA room thermostat (optional)

KG100 C2 020

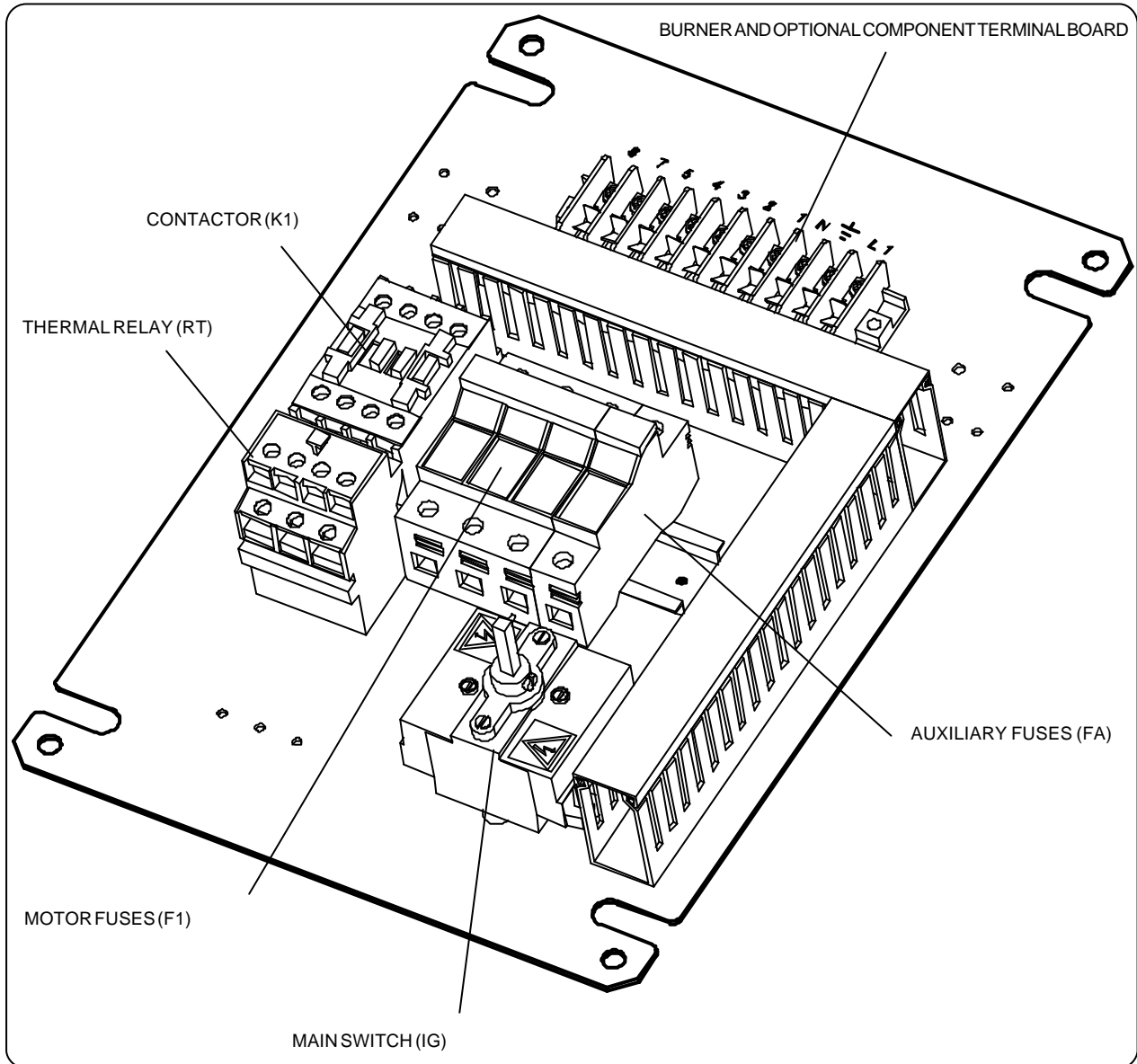
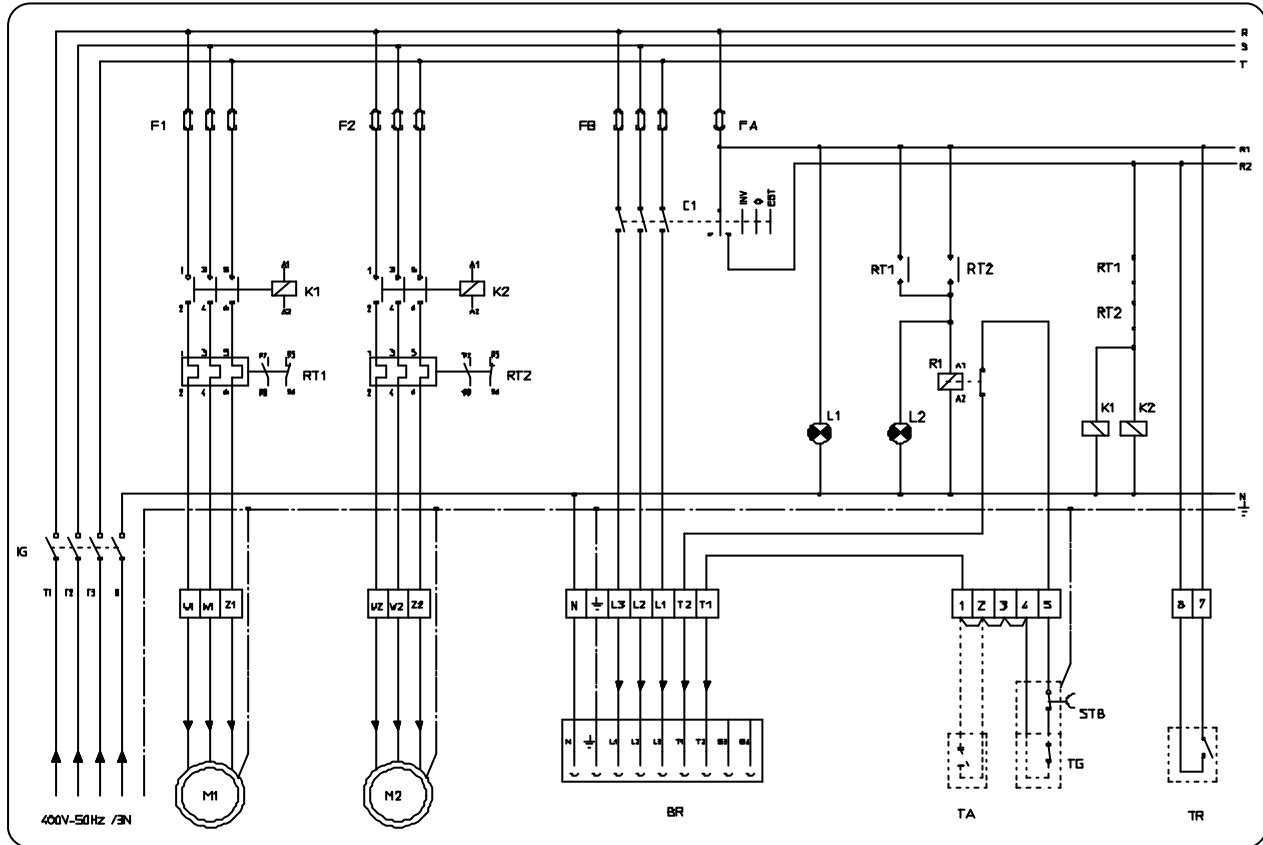

Diagram JP0083

Characteristics: 2 400V triphase motors, direct start-up, triphase/single-phase burner



LEGEND

- M fan 400V/50Hz triphase motor
- BR burner
- IG main switch
- C1 summer/0/winter switch
- STB limit thermostat
- TR fan thermostat
- TG burner stop thermostat
- FA auxiliary fuses
- F1 motor fuses
- FB burner fuses
- L1 line light
- L2 thermal relay light
- K1 contactor (230V coil)
- R1 relay (230V coil)
- RT1 motor thermal relay
- TA room thermostat (optional)

KG100 C2 021

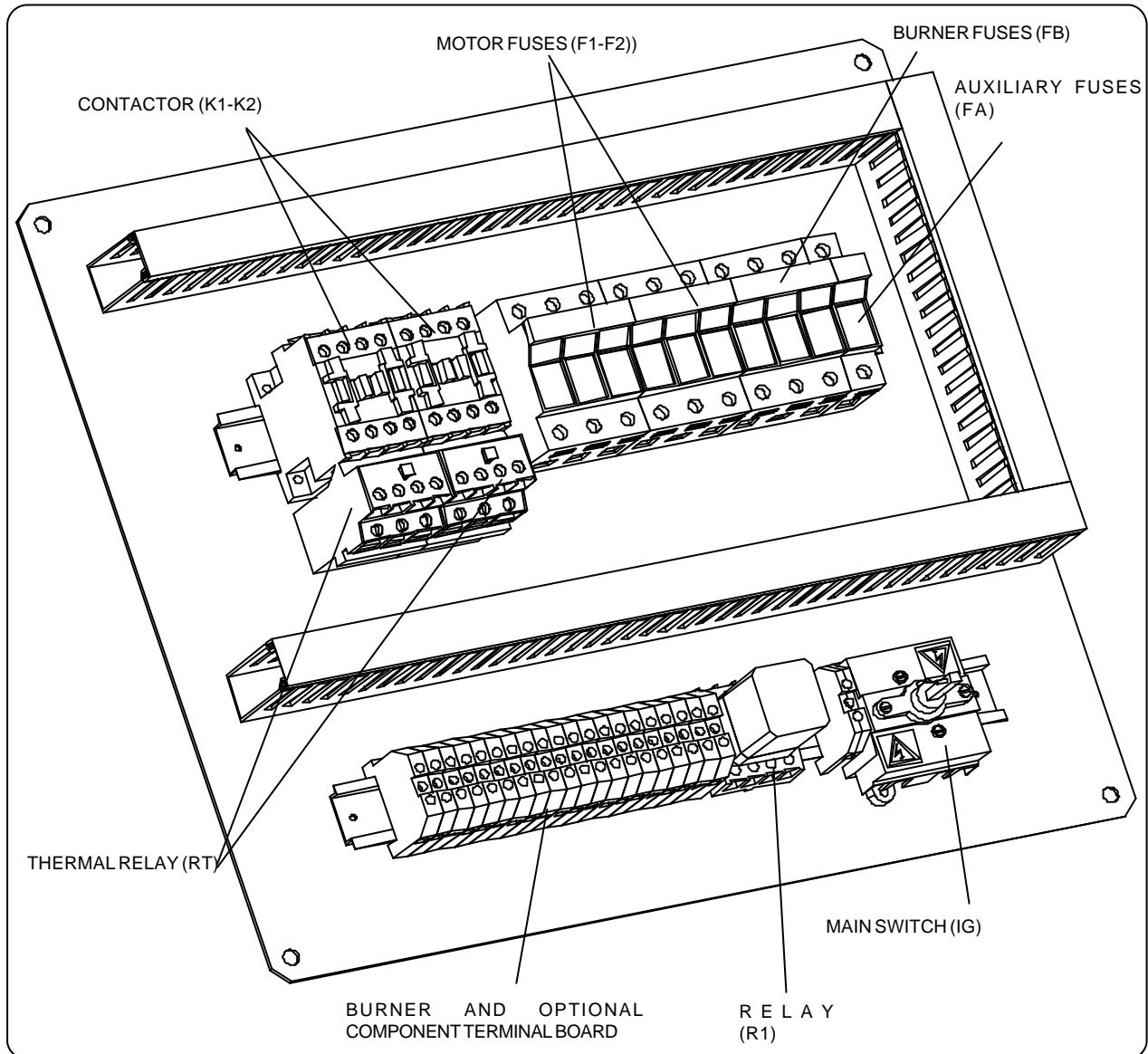
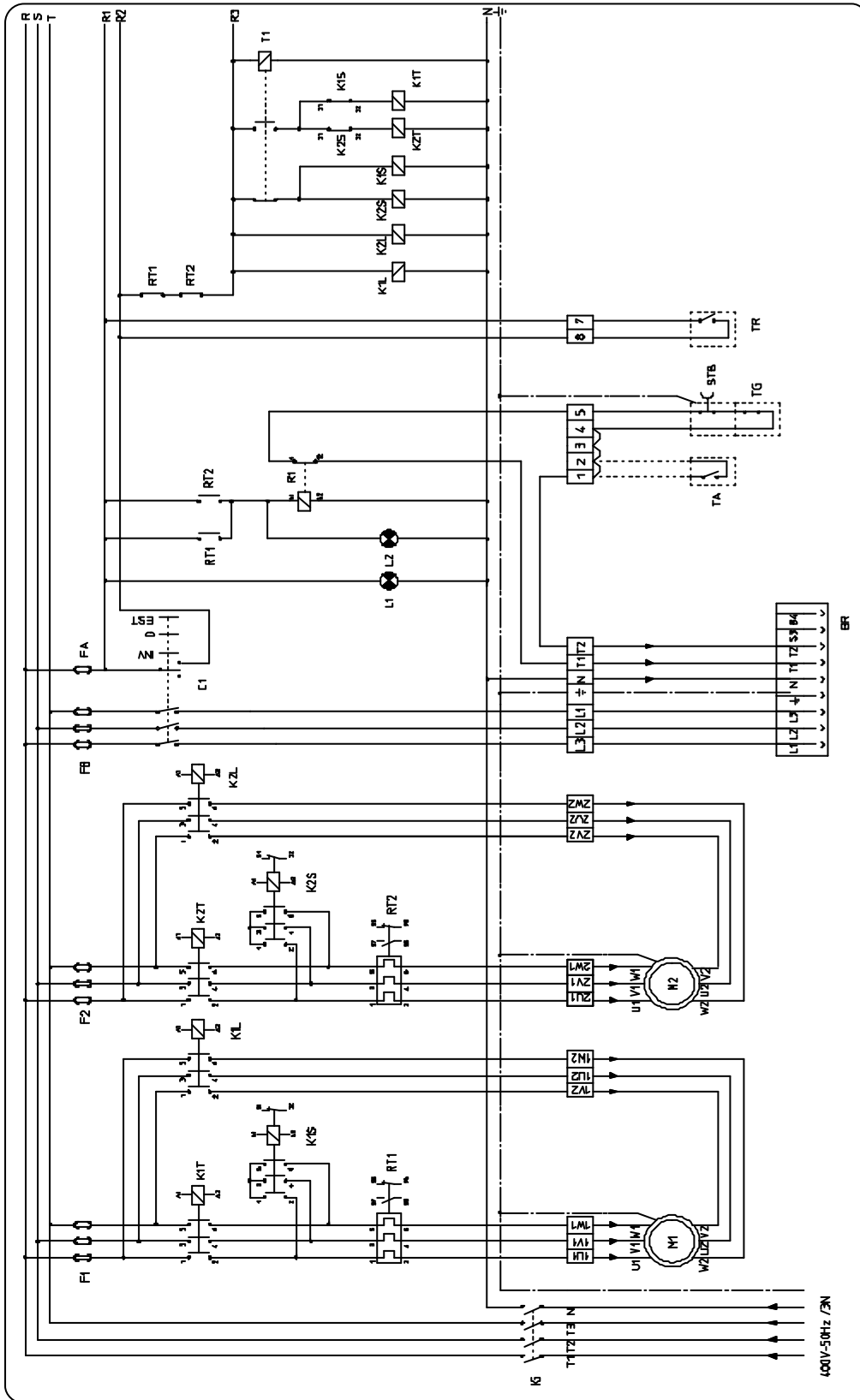

Diagram JP0084

Characteristics. 2 400V triphase motors, star/delta start-up, triphase/single-phase burner



LEGEND

- | | | | |
|----------|-------------------------------|----------|---|
| M1, M2 | fan 400V/50Hz triphase motors | K1S, K2S | contactors star connection (230V coil) |
| BR | burner | K1T, K2T | contactors delta connection (230V coil) |
| IG | main switch | R1 | relay (230V coil) |
| C1 | summer/O/winter switch | RT1, RT2 | motor thermal relay |
| STB | limit thermostat | T1 | timer (230V coil) |
| T | fan thermostat | TA | room thermostat |
| TG | burner stop thermostat | | |
| FA | auxiliary fuses | | |
| F1, F2 | motor fuses | | |
| FB | burner fuses | | |
| L1 | line light | | |
| L2 | thermal relay light | | |
| K1L, K2L | contactors (230V coil) | | |

KG100 C2 021

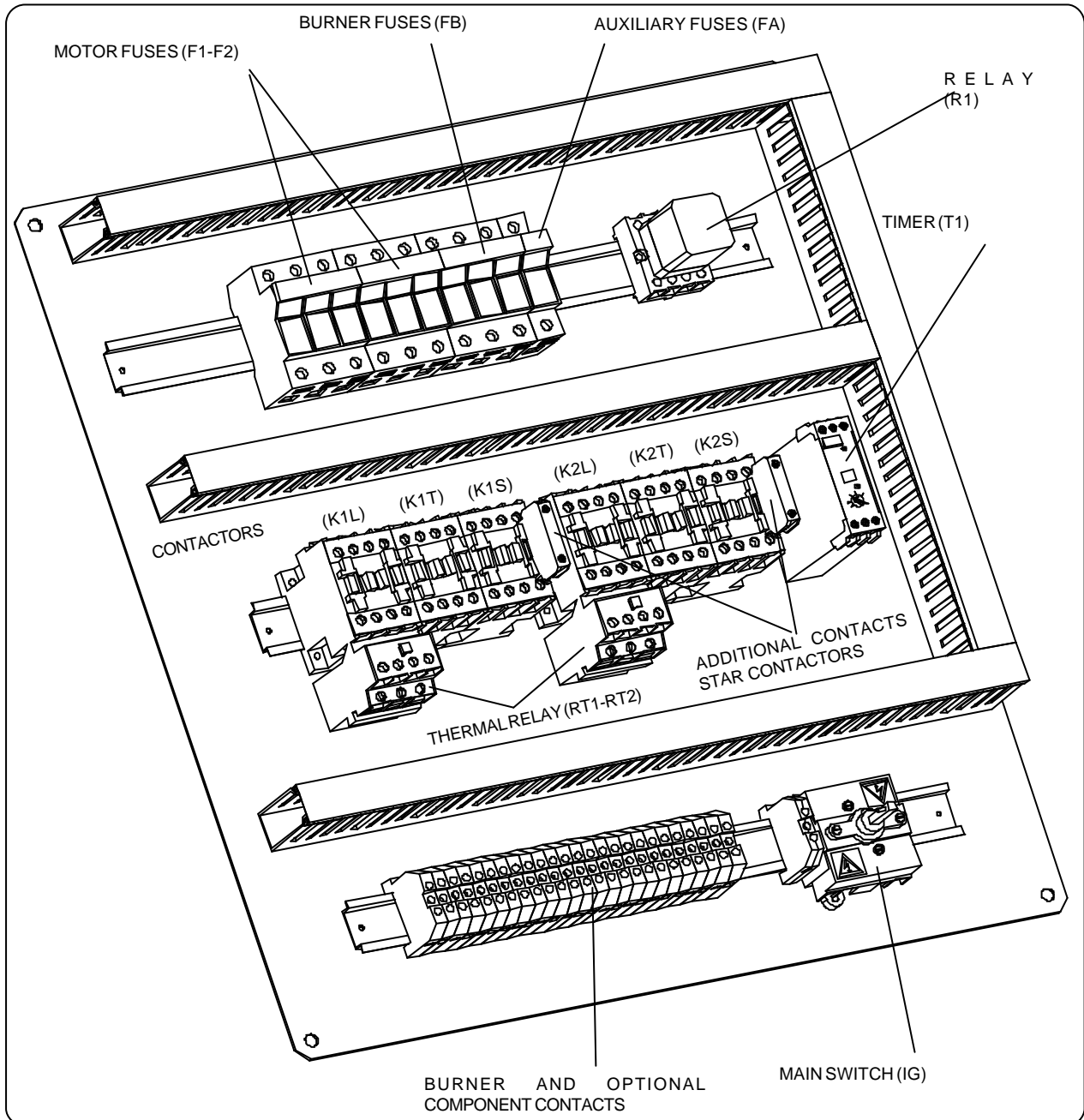

7.2 Electrical Motor Wiring

Motor wiring and testing on PKA/E heaters are accomplished before delivery. Therefore, it will only be necessary to wire a motor if it needs to be replaced. Wiring type depends on motor type (single-phase or triphase) and, in case of triphase motor, on type of start-up (direct or star-delta).

Single-phase Motor

Connection terminals are:

N (neutral),

A (for minimum rotation speed of the motor)

B (for maximum rotation speed of the motor)

NOTE: A third terminal C (not connected) is available for motor third speed. However, in standard switchboard, C2 switch does not allow three speeds.

IMPORTANT: Make sure that the motor to install is fully compatible to the one to replace. Contact Nordair-Niche Service for information.

NOTE: Wiring diagram table shows motor features and start-up type for each heater model.

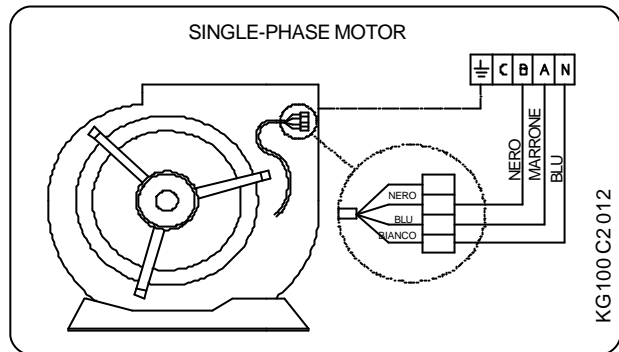

Triphase Motor, Direct Start-up

In units with only one motor, this is directly connected to the thermal relay.

In units with two motors, they are connected to terminals U1, W1, V1 and U2, W2, V2.

In both cases, motor grounding wire must be connected to the internal plaque of the switchboard using supplied screws.

IMPORTANT: Motors installed on direct start-up units can be 230/400V or 400/690V. The figure shows connection type according to the motor. If a 230/400V motor is used, star connection is required. If a 400/690 motor is used, delta connection will be necessary.

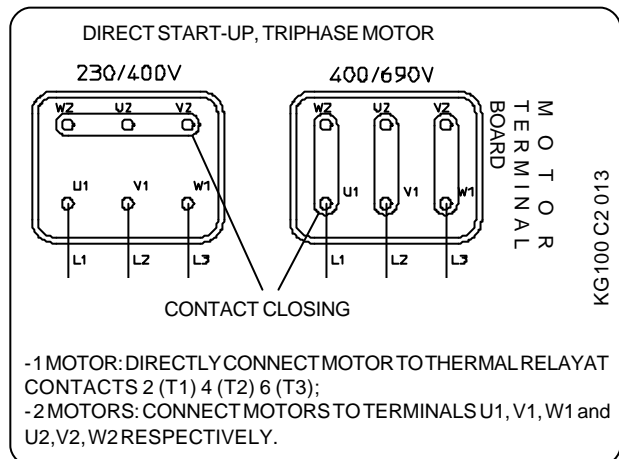

Triphase Motor, star/delta start up

All heaters that can use star/delta start-up, have two 400/690V motors. Motors of this type are equipped with 2 groups of terminals: U1,V1,W1 and U2,V2,W2. The figure shows motor wiring to terminals in the switchboard.

IMPORTANT: After a motor has been disconnected or replaced, DO CHECK fan rotation sense before restarting it.

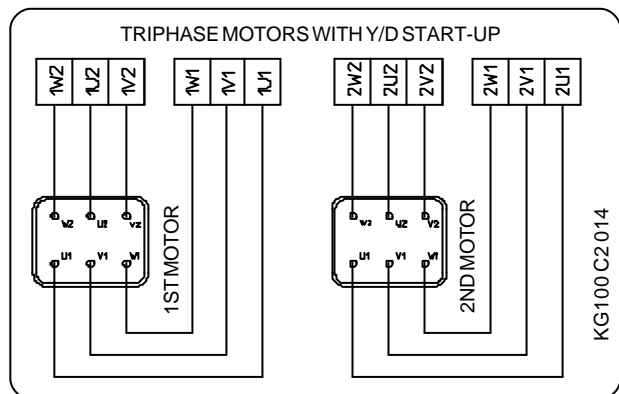

7.3 First Start-up Checking

Go through the following checklist during first start-up.

Combustion

Check:

- burner nozzle length
- fuel flow to the burner
- combustion parameters

Electrical components

Check:

- power supply
- rotation direction of fans
- motor absorption and air flow

Safety controls

Check:

- safety thermostat (STB+TG or LIMIT)
- fire stop gate microswitch (if installed)
- room thermostat
- fan thermostat (TR or FAN)

Combustion check

It is recommended to check that burner nozzle is suitable for use (see paragraph 6.6)

Check fuel flow:

- at the meter, for gas burners;
- using nozzle pressure/flow tables for gasoil.

If fuel flow cannot be measured, set the burner by checking combustion parameters.

Reference values for CO₂ content and, therefore, for O₂ excessive air for different types of fuel are listed below.

Natural gas	CO ₂ content	9,7% ± 0,2
G.L.P.	CO ₂ content	10,2% ± 0,2
Gas oil	CO ₂ content	12,5% ± 0,3

The CO₂ values reported can undoubtedly be improved without unburnt residue. However, it is better to keep an high level of excess air to balance possible operative changes in time.

Once the combustion is adjusted, check flue temperature to determine heat flow.

Rated flow is reached when net flue temperature ranges from 200°C to 220°C, maximum flow when flue temperature ranges from 270°C to 290°C and minimum flow when it ranges from 120 °C to 140°C.

If combustion efficiency is known and if CO₂ content is similar to the value shown before, use the diagrams on page 6 to find out the heat output assured by relevant efficiency level.

Electrical Components

Before powering the unit, check that power rating matches

requirements.

In units with triphase burner, check fan rotation direction. If the heater has two fans, make sure they both turn in the required direction.

Use a suitable snap-on ammeter to verify absorption rate for each motor. Where star/delta start-up is used, the test must be carried out before line contactor (KL).

The table on page 29 shows maximum absorption values for each heater and each motor.

An absorption rate 15% lower than max value means that air flow is lower than rated flow. To restore rated air flow, either increase fan revolution number by replacing one of the pulleys, or identify and remove losses in the air distribution system.

An absorption rate higher than rated value means that air circuit resistance is lower than expected. Therefore, to reach rated value, create limited pressure losses in order to decrease power absorption by the motors.

Safety Controls

Each heater and its relevant safety devices undergo electrical tests at the plant. However, proper operation of these devices depends on on-site electrical wiring.

Before starting the heater, check:

- Safety thermostat STB+TG or LIMIT

If double thermostat STB+TG is installed, it's enough to lower TG value until the burner turns off, then restore TG value. If LIMIT thermostat is installed, turn the crown clockwise till the right mark passes set reference, verify that the burner turns off, then release the crown that will automatically return to measured temperature value.

This test is mandatory on models above 190N since safety devices are installed on thermostat series, not on burner feeding as in lower models.

- Fire stop gates

If fire stop gates are installed on the unit, check that when the gate closes, the burner, and possibly the fan, turn off.

- Room thermostat

Check that the room thermostat and the timer turn off the burner but not the fan. The fan will stop after the heat exchanger has cooled down.

- TR or FAN thermostat

Make sure that the thermostat starts the fan in advance without activating the safety thermostat and that it doesn't allow cold air to blow from louvres when it's turned off.

8. COUPLING HEATERS-BURNERS

TYPE	NORDAIR-NICHE-THERMOVUR				BALTUR		CIB UNIGAS		
	Gasoil	kW max	Gas	kW max	Pgas mbar	gas	kW max	gas	kW max
PKA/E 032	LO0041-1L001		MG0041-1L151			SPARKGAS 3 BTG3		NG35	M-.TN.L.IT.A.0.15
PKA/E 035	LO0060-1L001		MG0041-1L151	35		SPARKGAS 3 BTG3		NG35	M-.TN.L.IT.A.0.15 35
PKA/E 060	LO0060-1L001 M0116-1L001	55	MG0075-1L101 MG0090-1L151 MG0120-1L201	60 80		BTG 6 BTG 11 BTG 11 P	50	NG70 NG90 S10	M-.TN.L.IT.A.0.10 60 M-.TN.L.IT.A.0.15 80 M-.TN.L.IT.A.0.20
PKA/E 100	M0116-1L001		MG0120-1L201 MG0140-2L201			BTG 11 SPARKGAS 20 BTG 11 P SPARKGAS 20 P	90 90	S10 S10	M-.TN.L.IT.A.0.20 M-.AB.L.IT.A.0.20
PKA/E 120	M0116-1L001 M0209-1L001	100	MG0120-1L201 MG0200-1L251 MG0140-2L201	100		SPARKGAS 20 SPARKGAS 20 P		S10 S18 S10	M-.TN.L.IT.A.0.20100 M-.TN.L.IT.A.0.25 M-.AB.L.IT.A.0.20
PKA/E 140	M0209-1L001		MG0200-1L251 MG0140-2L201 MG0200-2L251	120		SPARKGAS 20 SPARKGAS 20 P BGN 17 DSPGN	150	S18 S10 S18	M-.TN.L.IT.A.0.25 M-.AB.L.IT.A.0.20120 M-.AB.L.IT.A.0.25
PKA/E 190	M0209-1L001	180	MG0200-1L251 MG0200-2L251 MG0355-1L251 MG0355-PM321 MG0355-MM321	180 180		SPARKGAS 20 SPARKGAS 30 SPARKGAS 20 P SPARKGAS 30 P BGN 26 DSPGN	170 170	S18 S18 NG350 NG350 NG350	M-.TN.L.IT.A.0.25180 M-.AB.L.IT.A.0.25180 M-.TN.M.IT.A.0.25 M-.PR.M.IT.A.0.32 M-.MD.M.IT.A.0.32
PKA/E 250	LO0420-2M001	250	MG0200-1L251 MG0200-2L251 MG0355-1L251 MG0355-PM321 MG0355-MM321			SPARKGAS 30 SPARKGAS 30 P BGN 26 DSPGN BGN 34 DSPGN	230	NG350 NG350 NG350	M-.TN.M.IT.A.0.25 M-.PR.M.IT.A.0.32 M-.MD.M.IT.A.0.32
PKA/E 320	LO0420-2M001		MG0355-1L251 MG0355-PM321 MG0355-MM321 MG0420-1L251 MG0420-PM321 MG0420-MM321	310 310 310		SPARKGAS 30 SPARKGAS 35 P BGN 40 P BGN 40 DSPGN	310 310	NG350 NG350 NG350 NG400 NG400 NG400	M-.TN.M.IT.A.0.25110 M-.PR.M.IT.A.0.32110 M-.MD.M.IT.A.0.32110 M-.TN.M.IT.A.0.25 M-.PR.M.IT.A.0.32 M-.MD.M.IT.A.0.32
PKA/E 420	LO0420-2M001 LO0570-2L001 LO0570-ML001	370	MG0570-PL401 MG0570-ML401			BGN 40 P BGN 60 P BGN 40 DSPGN BGN 60 DSPGN	370 370	NG550 NG550	M-.PR.L.IT.A.0.40 M-.MD.L.IT.A.0.40
PKA/E 550	M0698-2L001 M0698-PL001 M0698-ML001		MG0570-PL401 MG0800-2L501 MG0570-ML401 MG0800-ML501	550 550		BGN 60 P BGN 60 DSPGN		NG550 P60 NG550 P60	M-.PR.L.IT.A.0.40550 M-.AB.L.IT.A.0.50 M-.MD.L.IT.A.0.40550 M-.MD.L.IT.A.0.50
PKA/E 700	M0698-2L001 M1047-2L001 M0698-PL001 M1047-PL001 M0698-ML001 M1047-ML001	640 640	MG0800-2L501 MG0970-2L501 MG0800-ML501 MG0970-ML501	650 650		BGN 60 P BGN 100 P BGN 60 DSPGN BGN 100 DSPGN	650 650	P60 P65 P60 P65	M-.AB.L.IT.A.0.50650 M-.AB.L.IT.A.0.50 M-.MD.L.IT.A.0.50650 M-.MD.L.IT.A.0.50
PKA/E 900	M1047-2L001 M1047-PL001 M1047-ML001		MG0970-2L501 MG0970-2L651 MG1200-2L501 MG1200-2L651 MG0970-ML501 MG0970-ML651 MG1200-ML501 MG1200-ML651	750 850 750 850	40 40	BGN 100 P BGN 120 P BGN 100 DSPGN BGN 120 DSPGN	880 880	P65 P65 P72 P72 P65 P65 P72 P72	M-.AB.L.IT.A.0.50750 M-.AB.L.IT.A.0.65850 M-.AB.L.IT.A.0.50 M-.AB.L.IT.A.0.65 M-.MD.L.IT.A.0.50750 M-.MD.L.IT.A.0.65850 M-.MD.L.IT.A.0.50 M-.MD.L.IT.A.0.65

FLOOR STANDING HEATERS PK-N

TYPE	CUENOD		ECOFLAM		FINTERM/JOANNES		LAMBORGHINI		RIELLO	
		kW max	gas	kW max	gas	kW max	gas	kW max	Riello gas	kW max
PKA/E 032	NC 4		AZUR 0		AZ 3		EM 3		BS 1	
	C3		AZUR 40						BS 1 D	
PKA/E 035	NC6	35	AZUR 40		AZ3	32	EM 3	32	BS 1	
	C5				AZ5		EM 6		BS 1 D	
PKA/E 060	C8	60	AZUR 60	60	AZ9	60	EM6	60	BS 2	
	C10		AZUR 80		AZ12		EM9		BS 2 D	
									EM9/2	
PKA/E 100										
	C10		BLU 120 P		AZ12		EM 16		BS 3	
			BLU 120 PAB				EM16/2		BS 3 D	
PKA/E 120										
	C10	100	BLU 120 P	100	AZ12	100	EM 16		BS 3	
	C14		BLU 170 P		AZ18		EM16/2		BS 3 D	
			BLU 170 PAB							
PKA/E 140										
	C14	130	BLU 170 P	140	AZ18	140	EM 16	140	BS 3	
	C20		BLU 250 P		G28		EM 26		BS 3 D	
			BLU 170 PAB	140	G28/2		EM 26 M			
			BLU 250 PAB				EM16/2	140		
							EM26/2			
							EM 26 M			
PKA/E 190										
	C20	170	BLU 250 P		G28		EM 26		BS 3	165
	C24		BLU 250 PAB		G28/2		EM 26/2		BS 4	
							EM 26/M		BS 3 D	165
									BS 4 D	
PKA/E 250										
	C28		BLU 350 P		GAS35		EM 35		BS 4	220
			BLU 350 PAB		GAS P45/2		EM 40/2		RS 28/1 tl	
					GAS P45/M		EM40/M		BS 4 D	220
									RS 28 LP tl	
									RS 28/M tl	
PKA/E 320										
	C28	290	BLU 350 P	300	GAS35	310	EM 35	280	RS 28/1 tl	280
	C34		BLU 500 P		GAS50		EM 40/2		RS 38/1 tl	
			BLU 350 PAB	300	GAS P45/2		55 PM/2	280	RS 28 LP tl	280
			BLU 500 PAB		GAS P45/M		EM40/M		RS 38 LP tl	
			MODULAIR	P40			55 PM/2	280	RS 28/M tl	280
							RS 38/M tl			
PKA/E 420										
	C34	380	BLU 500		GAS50		55 PM/2		RS 38/1 tl	400
	C70		BLU 500 PAB		GAS P45/2		55 PM/M		RS 38 LP tl	400
			MODULAIR	P40420	GAS P45/M				RS 50 LP tl	
			MODULAIR	P55					RS 38/M tl	400
PKA/E 550										
	C70		BLU 700 P		GAS P55/2		55 PM/2	490	RS 50 LP tl	530
			BLU 500 PAB	460	GAS P55/M		70 PM/2		RS 70 LP tl	
			BLU 700 PAB				55 PM/M	490	RS 50/M tl	530
			MODULAIR	P55			70 PM/M		RS 70/M tl	
PKA/E 700										
	C100		BLU 1000 PAB		GAS P75/2		70 PM/2	690	RS 70 LP tl	
			MODULAIR	P75	GAS P75/M		140 PM/2		RS 70/M tl	
							70 PM/M	690		
							140 PM/M			
PKA/E 900										
	C100	900	BLU 1000 PAB	880	GAS P100/2		140 PM/2		RS 100 LP tl	
	C120		BLU 1600 PAB		GAS P100/M		140 PM/M		RS 100/M tl	
			MODULAIR	P90						



Due to continuous product innovation, Nordair/Niche reserves the right to change product specification without due notice.

NORDAIR is a registered trademark of Ambi-Rad limited
NICHE is a registered trademark of Ambi-Rad limited

Nordair/Niche (Northern Office)

6-14 Bean Leach Road
Hazel Grove
Stockport
Cheshire
SK7 4LD
United Kingdom

Telephone 0161 482 7900
Facsimile 0161 482 7901
Email sales@nordair.co.uk
Website www.nordair.co.uk

Nordair/Niche (Southern Office)

Unit 4 Chilford Court
Braintree
Essex
CM7 2QS
United Kingdom

Telephone 01376 332200
Facsimile 01376 332201
Email sales@niche.ltd.uk
Website www.niche.ltd.uk



An Ambi-Rad Group company