

**Gas fired room sealed unit heaters
centrifugal**

**TECHNICAL INFORMATION, ASSEMBLY
INSTRUCTIONS, USE AND MAINTENANCE**

RS/UHC / UF RS/UHC-2 / 2UF

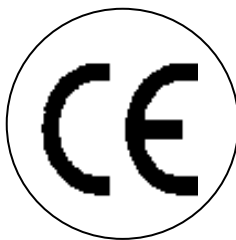
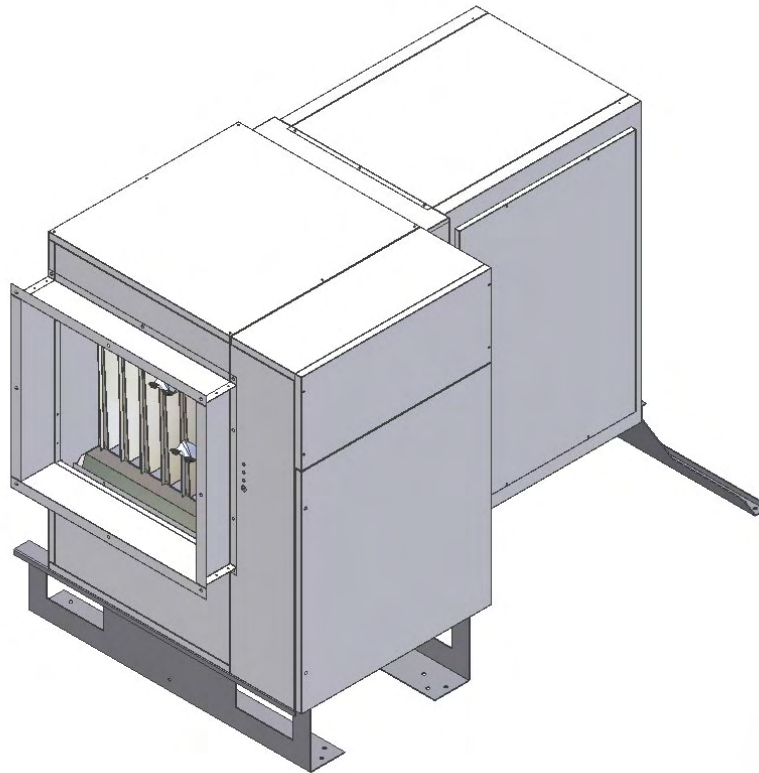

August 2003



BENSON

**BENSON HEATING
LUDLOW ROAD
KNIGHTON
POWYS,
LD71LP U.K.**

Benson Heating is a Division of
Benson Climate Systems Ltd

COMPLIANCE NOTICES

The Benson RS/UHC range of warm air heaters detailed herewith are manufactured for Benson Heating within the parameters of ISO 9002.

The Benson RS/UHC range has been independently tested and assessed, and has been found to meet the Essential Requirement of the following European Directives:

Gas appliance Directive (90/396/EEC)
 Machinery Directive (89/392/EEC) 91368/EEC 93/44/EEC 93/65/EEC
 Low Voltage Directive (73/23/EEC)
 Electromagnetic Compatibility Directive (98/336/EEC and 91/31/EEC)
 Product Liability Directive (65/374/EEC)

The manufacturer has taken reasonable and practical steps to ensure that Benson RS/UHC range of Heaters are safe and without risk when properly used. These heaters should therefore only be used in the manner and purpose for which they were intended, and in accordance with the recommendations detailed herewith. The heaters have been designed, manufactured, assembled, inspected, and tested, with safety and quality in mind, there are certain basic precautions which the installer and user should be aware of, and they are strongly advised to read the appropriate sections of the information pack accompanying the heater, prior to installation or use.

Benson Heating supports all new products being supplied to their customers with a comprehensive information pack; this clearly defines mandatory instructions for the safe installation, use, and maintenance, of the appliance(s).

Where proprietary items are incorporated into Benson Heating products, detailed information and instructions are also provided as part of the information pack.

It is the responsibility of the installer, owner, user, or hirer, of such products supplied by Benson Heating, to ensure that they are familiar with the appropriate information/manuals, supplied by the manufacturer, and that they are suitably aware of the purpose of the manuals and the safety instructions. In addition, operators must be suitably trained in the use of the appliance so as to ensure its continued safe and efficient use.

Benson Heating has a commitment to continuous improvement, and therefore reserves the right to amend or change the specification of the RS/UHC Heater range subject to agreement from The Notified Body.

Contained within the text of the manual, the words '**Caution**' and '**Warning**' are used to highlight certain points.

Caution is used when failure to follow or implement the instruction(s) can lead to premature failure or damage to the heater or its component parts.

Warning is used when failure to heed or implement the instruction(s) can lead to not only component damage, but also to a hazardous situation being created where there is a risk of personal injury.

RANGE

Notified Body PIN Reference is 0694BN3750

| Type | SINGLE STAGE | | | | TWO STAGE | | | |
|------|--------------|-------------|--------------|------------|-------------|------------|---------------|------------|
| | STANDARD | | UP RATED FAN | | STANDARD | | UP RATED FAN | |
| | Model | Code | Model | Code | Model | Code | Model | Code |
| 1 | RS/UHC80 | 3NIGBCR026 | RS/UHC80/UF | 3NIGBC1026 | RS/UHC80-2 | 3NIGB2A026 | RS/UHC80-2UF | 3NIGB22026 |
| 2 | RS/UHC105 | 3NIGBCR036 | RS/UHC105/UF | 3NIGBC1036 | RS/UHC105-2 | 3NIGB2A036 | RS/UHC105-2UF | 3NIGB22036 |
| 3 | RS/UHC140 | 3NIGBCR046 | RS/UHC140/UF | 3NIGBC1046 | RS/UHC140-2 | 3NIGB2A046 | RS/UHC140-2UF | 3NIGB22046 |
| 4 | RS/UHC200 | 3NIGBCR066 | RS/UHC200/UF | 3NIGBC6066 | RS/UHC200-2 | 3NIGB2B066 | RS/UHC200-2UF | 3NIGB23066 |
| 5 | RS/UHC260 | 3NIGBCR086 | RS/UHC260/UF | 3NIGBC6086 | RS/UHC260-2 | 3NIGB2B086 | RS/UHC260-2UF | 3NIGB23086 |
| 6 | RS/UHC325 | 3NIGBCR0106 | RS/UHC325/UF | 3NIGBC6106 | RS/UHC325-2 | 3NIGB2B106 | RS/UHC325-2UF | 3NIGB23106 |

VERSION SINGLE STAGE

The heater has a single stage gas valve, and a standard centrifugal fan. An optional uprated fan version is available for installations that require higher static pressures.

VERSION TWO STAGE

The heater has a two stage Hi /Lo gas valve, and a standard centrifugal fan. An optional uprated fan version is available for installations that require higher static pressures.

GUARANTEE

The heater is supplied with a 2 year warranty on all parts.

In addition to this there is also a 10 year time related warranty on the combustion chamber.

The warranty commences from the date of despatch from the manufacturer, and is subject to the terms detailed within the manufacturer 'conditions of business'.



The warranty may be invalidated if:

- a) The warranty registration/commissioning card has not been completed and returned to the manufacturer
- b) The installation is not in accordance with the general requirements of this manual
- c) The flue arrangement and air supply for the heater are not in accordance with the manufacturers recommendations, codes of practice, or similar standards
- d) Air flow through the heater is not in accordance with the manufacturers technical specifications
- e) Internal wiring on the heater has been tampered with or unauthorised service/repairs undertaken
- f) The main electrical supply input to the heater has been interrupted during the heating mode
- g) The heater has been subject to and affected by the ingress of water in any form
- h) The heater is not operated at the rating(s) laid down in the manufacturers technical specifications
- i) The heater has not been operated or used within the normal scope of its intended application
- j) The manufacturer's recommended minimum service requirements have not been complied with



All warranty claims must contain the following information to enable processing to take place;

- (1) Heater model
- (2) Heater serial number
- (3) Order reference/date of order, together with full installation details (name and address)
- (4) Details or symptoms of fault
- (5) Installers name and address.

Faulty parts must be returned to the manufacturer Spares Department, the address of which is provided on the rear cover of this manual. Any such parts will undergo inspection to verify the claim. Replacement parts supplied prior to this may be charged, and a credit supplied upon subsequent validation of the warranty claim. Consumable items are specifically not included within the scope of the warranty.



Notification is required immediately a fault is suspected. The manufacturer will not accept responsibility for any additional damage that has been caused, expense incurred, or consequential loss resulting from any failure of the heater(s).



Ensure that the heater is able to operate within the parameters shown on the data plate and the technical data within the manual.
Incorrect gas settings may lead to condensation within the combustion if too low, and overheating if too high both will cause damage to the heat exchanger.

Any reference made to Laws, Standards, Directives, Codes of Practice or other recommendations governing the application and installation of heating appliances and which may be referred to in Brochures, Specifications, Quotations, and Installation, Operation and Maintenance manuals is done so for information and guidance purposes only and should only be considered valid at the time of the publication. Manufacturer cannot be held responsible from any matters arising from the revision to or introduction of new Laws, Standards, Directives, Codes of Practice or other recommendations.

INDEX

GENERAL

| | | |
|----------------------------|-------|----|
| Description of equipment | page. | 5 |
| Identification | " | 6 |
| Description | " | 7 |
| Technical data | " | 9 |
| Wiring diagram | " | 10 |
| Remote control connections | " | 14 |

FOR THE USER

| | | |
|----------------------------------|---|----|
| Operation | " | 15 |
| Servicing | " | 15 |
| Heater indication lights | " | 16 |
| Receipt of product and transport | " | 16 |
| Dimension and weight | " | 17 |

FOR THE INSTALLER

| | | |
|--|---|----|
| Installation | " | 19 |
| Installation clearances | " | 20 |
| Examples of installation | " | 21 |
| Accessories | " | 22 |
| Gas connection | " | 23 |
| Flue and combustion options | " | 24 |
| Electrical control panel and circuit board | " | 28 |
| Electrical connections | " | 28 |

TECHNICAL ASSISTANCE SERVICE

| | | |
|--------------------------|---|----|
| Duct connection | " | 29 |
| Return air connections | " | 30 |
| Protection | " | 30 |
| Pre commissioning checks | " | 30 |
| Initial start up | " | 31 |
| Gas conversion | " | 32 |
| Thermostat | " | 34 |
| Fan | " | 35 |
| Control | " | 35 |
| Maintenance | " | 36 |
| Fault finding | " | 38 |

DESCRIPTION OF EQUIPMENT

Heat exchanger

- Stainless steel construction easily accessible for inspection and cleaning and maintenance operations.
- Patented exchange elements made in stainless steel modular sections with large surface area, trapezoidal in section with swirl impressions for which give thermal yields of over 90%. The exchange elements have no welded joints or seams near to the burner flame so as to avoid exposure of any weak points.

Flue outlet with integral flue venter to assist dispersal of combustion gasses.

External casing

Encloses all controls giving a good aesthetic appearance and streamlined look whilst allowing for easy inspection.

The casing consists of removable panels and also includes:

A burner compartment which is totally sealed off, with an inspection door;

Radiant heat insulation on the surfaces closest to the heat exchanger;

Outlet grille for directing the warm air.

Fan assembly

One or two centrifugal fans operated by a single electric motor via pulleys and belts the motor pulley is adjustable to give effective cooling of the combustion / heat exchanger.

The position of the fan(s) produce greater effective cooling of the combustion chamber, optimising the heat exchange and avoiding overheating.

An up rated fan is also available.

Control and protection equipment

This is electronic with ionisation flame detection and ignition controls.

The equipment controls and monitors the operation of the burner in the following sequence.

Checks the differential pressure switch operated by the flue venter is in the closed position and the flue venter is working;

Checks the air temperature of the combustion chamber (below 100°C)

Opens the gas solenoid valve;

Starts burner ignition;

Detects flame signal from flame probe and allows normal heater operation.

Failure in any of the above sequence will result in the control box shutting the gas valve and stopping the heater.

The Heater will go to lockout and can be only be reset manually by pressing the red light on the front of the equipment.

Gas solenoid valve

The multifunctional 1 stage gas valve (**Single Stage**) and 2 Stage gas valve (**Two Stage**) consists of:

- Safety solenoid valve
- A regulatory solenoid valve
- A pressure regulator
- A gas filter

Atmospheric multigas burner assembly

Consisting of:

- Galvanised steel manifold
- Visual monitoring aperture for the electrodes and flame observation
- 3 or 6 stainless steel burner bars
- Ignition and Detection electrodes

Note: the type 4-5-6 are equipped with two gas manifolds, each manifold has an ignition electrode.

Control and safety thermostat

The heater is controlled by three thermostats pre set to the following.

LM Limit thermostat (100°C)

Capillary type. Manual Reset

Act as a safety device and shuts down the burner if the heater goes to overheat. The yellow light will flash when in overheat. The LIMIT thermostat is reset by the removal of the plastic cap situated on the control panel inside the heater, and manually pressing the reset button, after first ensuring that the fault has been rectified. (calibrated at 100°C). Replace cap after resetting thermostat.

TR Regulatory thermostat (0 – 90°C)

Capillary type. Automatic reset.

The thermostat monitors the temperature of the airflow and will shut down the burner if the set level is exceeded (calibrated at 70°C). Once the fan has sufficiently cooled the heat exchanger, the burner will automatically relight. The yellow indication light will flash until the burner relights. If this fault persists the cause should be investigated.

SND Control probe (0 – 40°C)

Connected in series with the thermostat TR. The probe will start the fan when the temperature reaches 30°C (approximately 30 seconds from burner ignition). When the desired room temperature is reached and the burner shuts down, the probe will allow the fan to run for approximately 3-minutes until the heat exchanger has cooled sufficiently.

The probe also monitors the operation of the TR thermostat and if a fault is detected will change the yellow flashing light to a continuous on light. In addition to this the SND probe monitors the temperature of the return air and will switch off the fan prior to the 3-4 minute run on time if the heat exchanger has cooled sufficiently (this avoiding cold air flow from the heater).

Differential air pressure switch

This switch will shut the gas valve if the flue venter fails or there is an obstruction in the flue, or in the air inlet preventing the flue venter from operating.

Flue venter

This consists of a centrifugal fan which

is run by an electric motor with self-cooling rotor the cooling air is supplied through a duct pipe situated in the axial fan air flow.

Indication lights

These consist of three different coloured lights on the front of the heater:

- **Green light** – indicates normal working. Illuminates when the gas solenoid valve opens
- **Yellow light** – indicates the operation of the LM, TR and SND thermostat.
- **Red light** - to indicate lockout of the heater by the control circuit failure.
- **Reset button** to reset the lockout

Flue spigot

A flue spigot (100mm) is situated at the rear of the heater for connection of flue pipes.

Combustion air spigot

A combustion air spigot (100/150mm) with a safety mesh of less than 16 mm Ø on the rear of the heater allow for connection of combustion air pipe

IDENTIFICATION

! If the **TECHNICAL DATA** is lost or damaged ask Benson Technical Department for duplicate .
Check code and model is as data plate.

Position of data plate

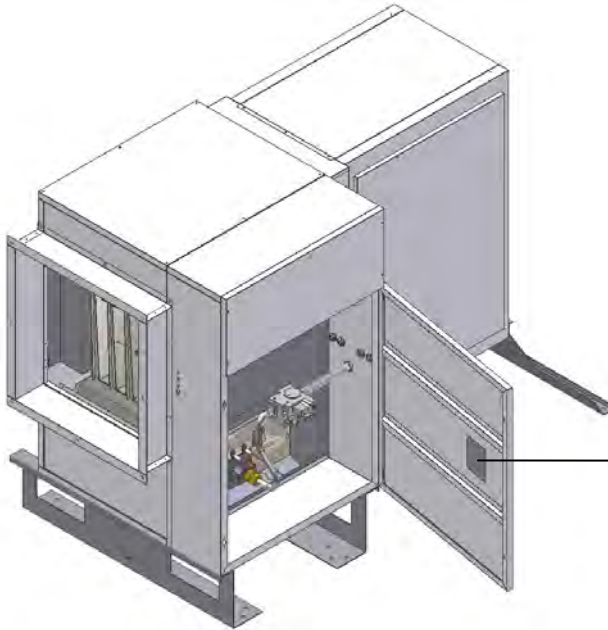

| | | | |
|---------------------|---|--|--|
| Manufacturer | | CE | |
| AIR HEATER | | | |
| Model | <input style="width: 100%;" type="text"/> | | |
| Serial Number | <input style="width: 100%;" type="text"/> | | |
| Country | <input style="width: 50%;" type="text"/> | PIN | <input style="width: 50%;" type="text"/> |
| Category | <input style="width: 50%;" type="text"/> | Code | <input style="width: 50%;" type="text"/> |
| Type | <input style="width: 50%;" type="text"/> | Year | <input style="width: 50%;" type="text"/> |
| Nominal Heat INPUT | | | kW |
| Nominal Heat OUTPUT | | | kW |
| Air Flow (+15°C) | | | m³/h |
| Electrical Supply | <input style="width: 100%;" type="text"/> | | |
| Electrical Power | | | W |
| Protection Rating | <input style="width: 100%;" type="text"/> | | |
| GAS TYPE | <input style="width: 25%;" type="text"/> | <input style="width: 25%;" type="text"/> | <input style="width: 25%;" type="text"/> |
| Supply Pressure | mbar | <input style="width: 25%;" type="text"/> | <input style="width: 25%;" type="text"/> |
| Head Pressure | mbar | <input style="width: 25%;" type="text"/> | <input style="width: 25%;" type="text"/> |
| Injector Diameter | mm | <input style="width: 25%;" type="text"/> | <input style="width: 25%;" type="text"/> |
| Gas Consumption | m³/h | <input style="width: 25%;" type="text"/> | <input style="width: 25%;" type="text"/> |

Packing label position

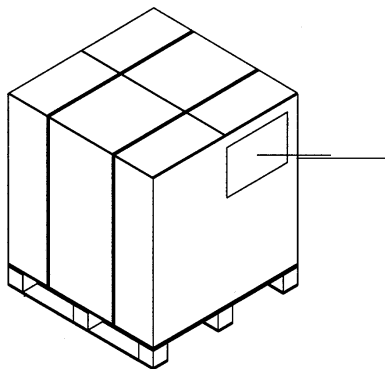

| |
|----------------------------|
| CE |
| Code Model Serial No |

DESCRIPTION

Type 1+4

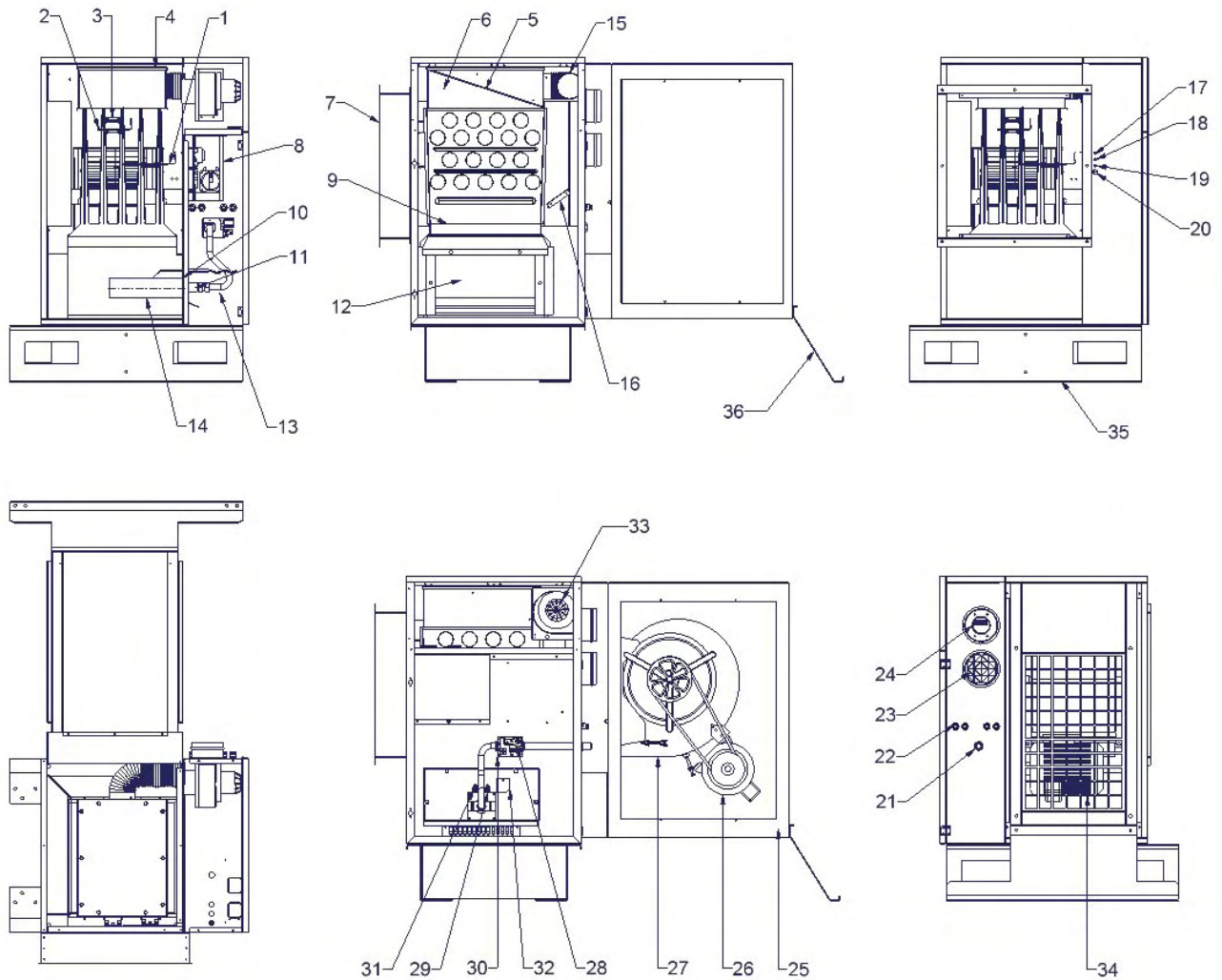

NOTE:

**Heaters type 1, 2, 3 have a single burner manifold.
Heaters type 4 have two burner manifolds**

- | | |
|--|---|
| <ul style="list-style-type: none"> 1. Regulation thermostat SND 2. FAN thermostat TR 3. LIMIT thermostat LM 4. Flue venter inspection door 5. Flue pipe 6. Flue manifold 7. Outlet Grille 8. Controls compartment 9. Heat exchanger 10. Burner plate insulation 11. Gas injector 12. Combustion chamber 13. Gas manifold 14. Burner bars | <ul style="list-style-type: none"> 15. Flue ducting 16. Deflector 17. Green power on light 18. Yellow limit indication light 19. Red light lockout indication 20. Lockout reset 21. Gas inlet connection 22. Electrical connections 23. Combustion intake air spigot 24. Flue spigot 25. Inlet casing 26. Fan Motor 27. Centrifugal Fan 28. Gas Solenoid valve 29. Ignition electrode 30. Gas pressure manifold test nipple 31. Flame detection electrode 32. Flame check aperture 33. Flue venter |
|--|---|

Type 5 and 6:

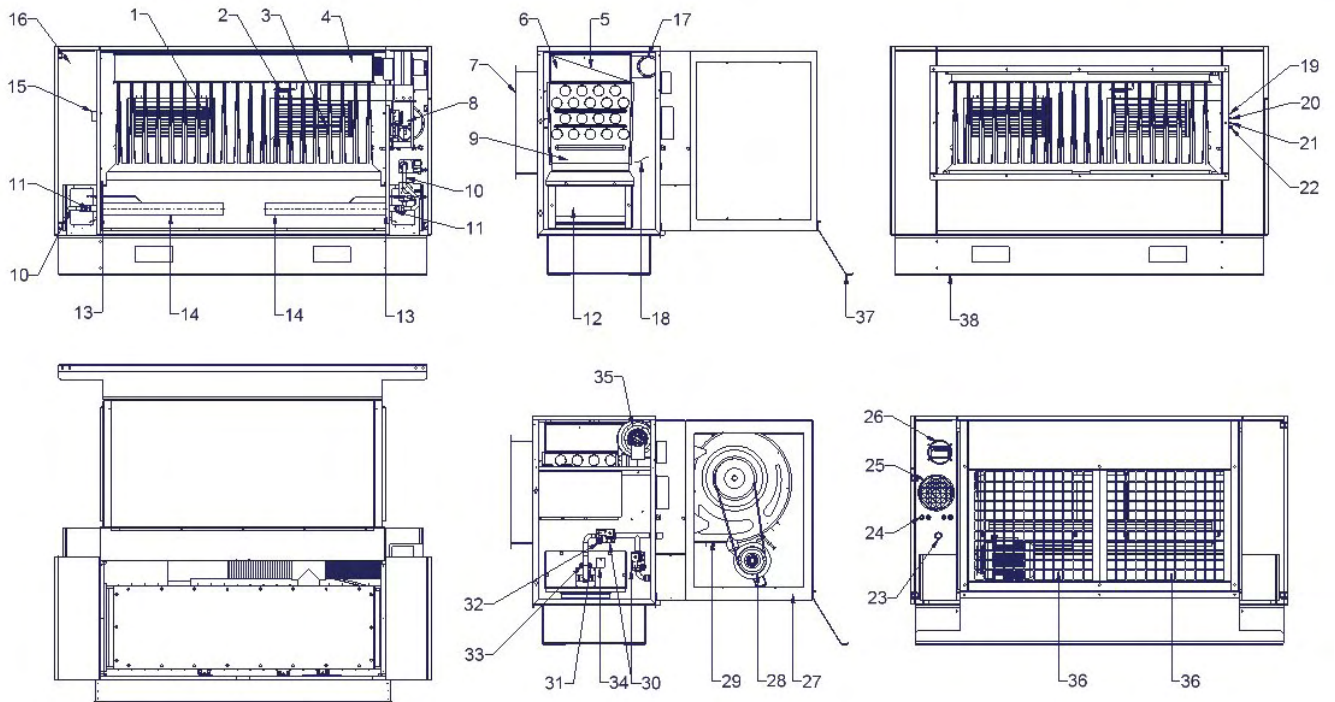

NOTE:

Heaters type 5 are supplied with 2 opposing burner manifolds
Heaters type 6 are supplied with 4 opposing burner manifolds

- | | |
|---|---|
| <ul style="list-style-type: none"> 1. Regulation thermostat 2. LIMIT thermostat 3. FAN thermostat 4. Flue venter inspection door 5. Flue pipe 6. Flue manifold 7. Outlet Grille 8. Controls Compartment 9. Heat exchanger 10. Gas manifold 11. Gas injector 12. Combustion chamber 13. Burner plate insulation 14. Burner tubes 15. Ignition transformer 16. Left burner casing 17. Flue ducting 18. Deflector 19. Green power light | <ul style="list-style-type: none"> 20. Yellow limit indication light 21. Red light lockout indication 22. Lockout reset 23. Gas inlet connection 24. Cable grips 25. Combustion intake air spigot 26. Flue spigot 27. Inlet casing 28. Fan Motor 29. Centrifugal Fan 30. Gas Solenoid valve (2 on type 5 and 6) 31. Ignition electrode 32. Gas pressure manifold test nipple 33. Flame detection electrode 34. Flame check aperture 35. Gas pressure manifold test nipple 36. Air inlet grille 37. Rear support 38. Base plate |
|---|---|

TECHNICAL DATA

| DESCRIPTION | TYPE | | | | | | UNIT |
|--|---|---------|---------|---------|---------|---------|--------------------|
| | 1 | 2 | 3 | 4 | 5 | 6 | |
| HEAT OUTPUT | 23,0 | 30,5 | 41,7 | 58,6 | 76,6 | 94,3 | KW |
| | 78.500 | 104.000 | 142.000 | 200.000 | 261.500 | 322.000 | Btu |
| HEAT INPUT | 25.4 | 33.8 | 46.3 | 65.0 | 85.0 | 104.7 | KW |
| (Nett) | 86.000 | 115.000 | 158.000 | 224.000 | 290.000 | 357.000 | Btu |
| EFFICIENCY | 90,1 | 90,2 | 90,1 | 90,1 | 90,1 | 90,1 | % |
| AIR FLOW +15°C | 1.820 | 2.920 | 4.130 | 5.900 | 7.900 | 8.750 | Nm ³ /h |
| MAX AIR OFF (ΔT) | 37 | 31 | 30 | 30 | 29 | 32 | °K |
| HEAT INPUT MIN (two stage) | 15,8 | 21,0 | 28,8 | 40,5 | 52,9 | 65,2 | KW |
| MIN AIR OFF (ΔT) (two stage) | 25 | 21 | 20 | 20 | 20 | 22 | °K |
| STATIC PRESSURE (standard) | 200 | | | | | | Pa |
| STATIC PRESSURE (uprated) | 500 | 450 | 440 | 470 | 440 | 500 | Pa |
| THERMOSTAT CALIBRATION | | | | | | | |
| - TR (auto reset) | 70 | | | | | | °C |
| - LM (manual reset) | 100 | | | | | | °C |
| - SND (auto reset) | 70 | | | | | | °C |
| FAN OPERATION | | | | | | | |
| - Fan on | 30 | | | | | | sec |
| - Fan off | 3 | | | | | | min' |
| Air pressure switch setting | 0,85 | 0,90 | 0,85 | 1,95 | 0,40 | 0,70 | mBar |
| Maximum flue resistancel | 70 | 70 | 70 | 70 | 160 | 115 | Pa |
| CENTRIFUGAL FAN | | | | | | | |
| - Type | AT 10-8 | AT 12-9 | AT12-12 | AT 12-9 | AT12-12 | AT12-12 | |
| - Number | 1 | 1 | 1 | 2 | 2 | 2 | N° |
| ELECTRICAL SUPPLY | 230V | 230V | 230V | 400V 3N | 400V 3N | 400V 3N | 50Hz ~ |
| RATED INPUT (standard motor) | 0,5 | 0,5 | 0,5 | 0,750 | 1,100 | 1,500 | KW |
| RATED INPUT (up rated motor) | 0,5 | 0,75 | 1,1 | 1,5 | 2,2 | 3,0 | KW |
| RUNNING CURRENT MAX(standard motor) | 3,7 | 3,7 | 4,0 | 2,0 | 2,8 | 3,6 | A |
| RUNNING CURRENT MAX (up rated motor) | 4,0 | 4,7 | 7,5 | 3,6 | 5,0 | 6,5 | A |
| ELECTRICAL PROTECTION | 40 | | | | | | IP |
| GAS CATEGORY | II _{2H3B/P} | | | | | | |
| INSTALLATION TYPES | B ₂₂ – C ₁₂ – C ₃₂ | | | | | | |
| OPERATIONAL LIMITS | | | | | | | |
| - Temperature | -15 / +40 | | | | | | °C |
| - Relative humidity (non condensing) | 70 | | | | | | % |
| WEIGHT (standard) | 122 | 133 | 156 | 200 | 267 | 311 | Kg |
| WEIGHT (up rated) | 122 | 135 | 159 | 204 | 274 | 318 | Kg |
| NATURAL GAS G20 | | | | | | | |
| - Number of injectors | 1 | 1 | 1 | 2 | 2 | 4 | N° |
| - Diameter of injectors | 410 | 480 | 555 | 500 | 540 | 450 | mm/100 |
| - Inlet pressure | 20 | | | | | | mBar |
| - Head pressure max | 13,0 | 13,0 | 13,0 | 10,0 | 13,0 | 10,5 | mBar |
| - Head pressure (two stage) | 7,0 | 6,5 | 6,5 | 7,0 | 6,5 | 5,0 | mBar |
| - Consumption max ⁽¹⁾ | 2,55 | 3,39 | 4,65 | 6,52 | 8,53 | 10,51 | Nm ³ /h |
| - Consumption min ⁽¹⁾ (two stage) | 1,79 | 2,38 | 3,25 | 4,57 | 5,97 | 7,36 | Nm ³ /h |
| PROPANE GAS G31 | | | | | | | |
| - Maximum gas head pressure | 35,0 | 35,5 | 35,5 | 34,5 | 35,5 | 34,5 | mBar |
| - Minimum gas head pressure (two stage) | 18,0 | 18,5 | 18,0 | 18,0 | 18,0 | 18,5 | mBar |
| - Consumption max ⁽²⁾ | 0,98 | 1,30 | 1,78 | 2,50 | 3,27 | 4,03 | Nm ³ /h |
| | 1,97 | 2,63 | 3,60 | 5,05 | 6,60 | 8,13 | Kg/h |
| | 3,88 | 5,16 | 7,07 | 9,92 | 12,97 | 15,98 | Litri/h |
| - Consumption min ⁽²⁾ (two stage) | 0,68 | 0,91 | 1,25 | 1,75 | 2,29 | 2,82 | Nm ³ /h |
| | 1,38 | 1,84 | 2,52 | 3,53 | 4,62 | 5,69 | Kg/h |
| | 2,72 | 3,62 | 4,94 | 6,04 | 9,08 | 11,19 | Litri/h |
| Mass products of combustion max | 0,0139 | 0,0185 | 0,0253 | 0,0356 | 0,0465 | 0,0573 | kg/s |

- (1) References:
 Atmospheric pressure 1013 mBar
 Gas temperature 15°C
- (2) Atmospheric pressure 1013mBar

WIRING DIAGRAM

Schematic layout:

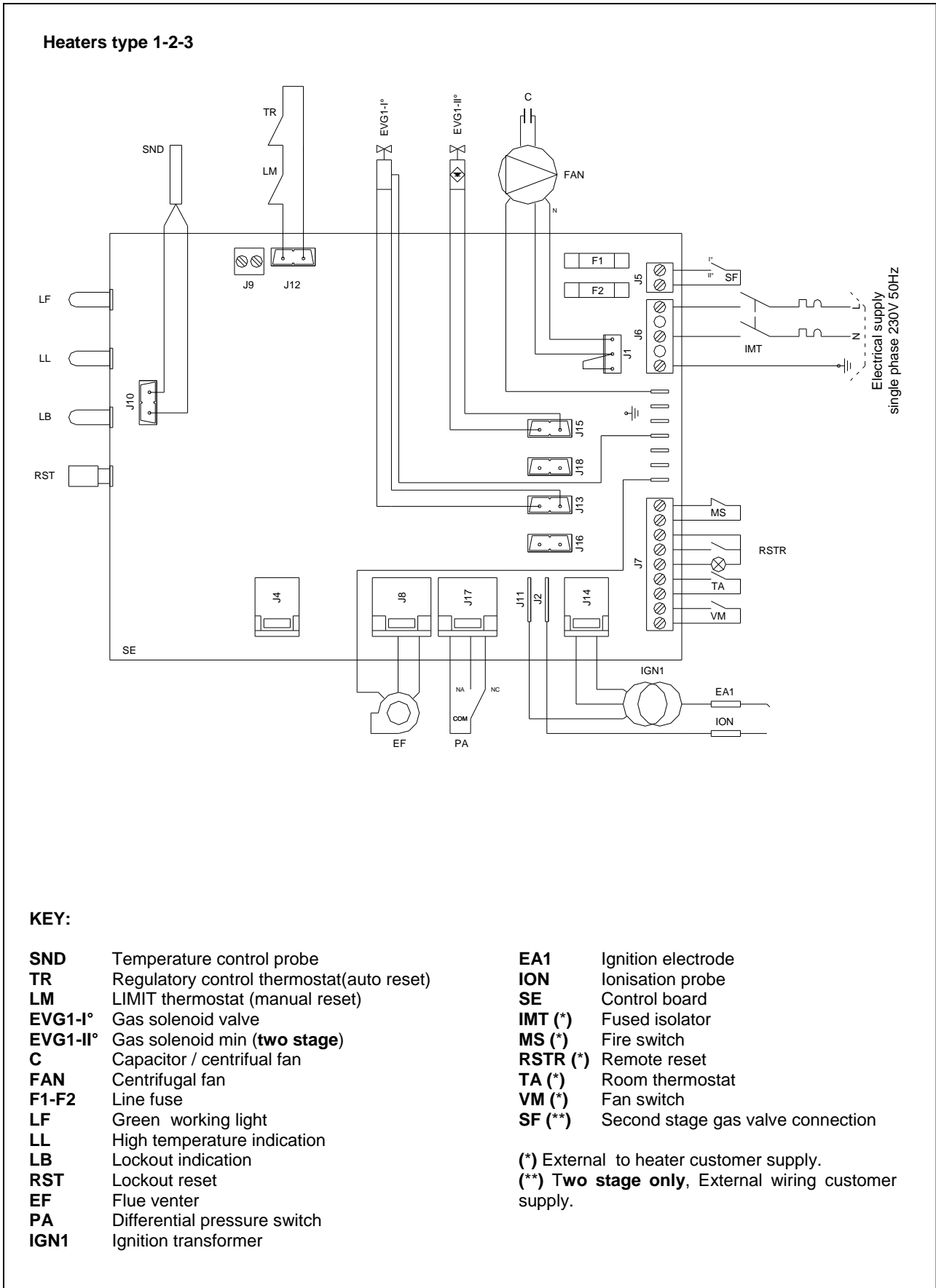

Heater type 2-3 up rated fan

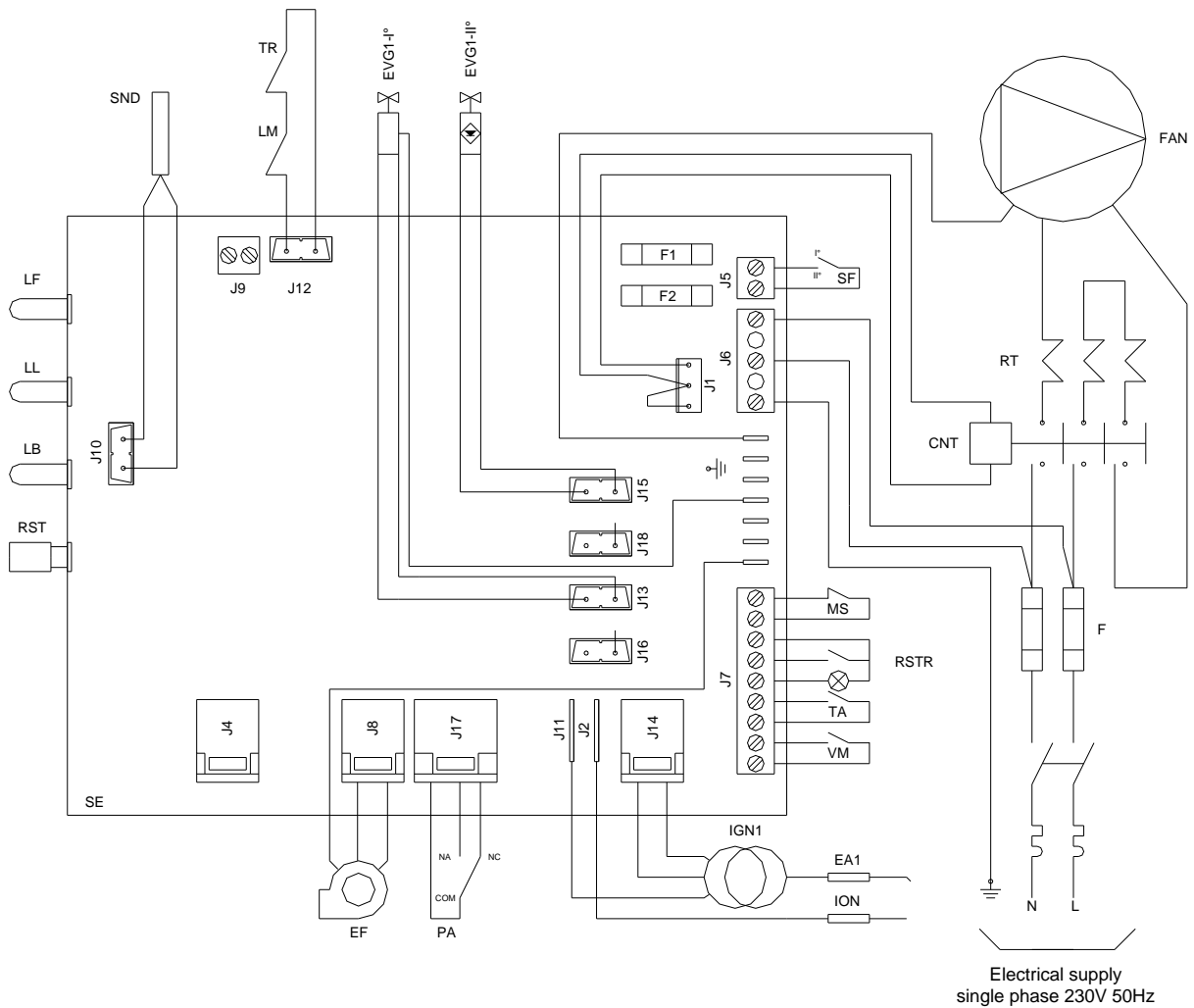

KEY:

| | |
|-----------------|---|
| SND | Temperature control probe |
| TR | Regulatory control thermostat(auto reset) |
| LM | LIMIT thermostat (manual reset) |
| EVG1-I° | Gas solenoid valve |
| EVG1-II° | Gas solenoid min (two stage) |
| C | Capacitor / centrifugal fan |
| FAN | Centrifugal fan |
| F1-F2 | Line fuse |
| LF | Green working light |
| LL | High temperature indication |
| LB | Lockout indication |
| RST | Lockout reset |
| EF | Flue venter |
| PA | Differential pressure switch |
| IGN1 | Ignition transformer |
| EA1 | Ignition electrode |

| | |
|-----------------|-----------------------------------|
| ION | Ionisation probe |
| SE | Control panel |
| RT | Relay fan motor |
| CNT | Fan contactor |
| F | Line fuse |
| IMT (*) | Fused isolator |
| MS (*) | Fire switch |
| RSTR (*) | Remote reset |
| TA (*) | Room thermostat |
| VM (*) | Fan switch |
| SF (**) | Second stage gas valve connection |

(*) External to heater customer supply.

(**) **Two stage only**, External wiring customer supply.

Heater type 4

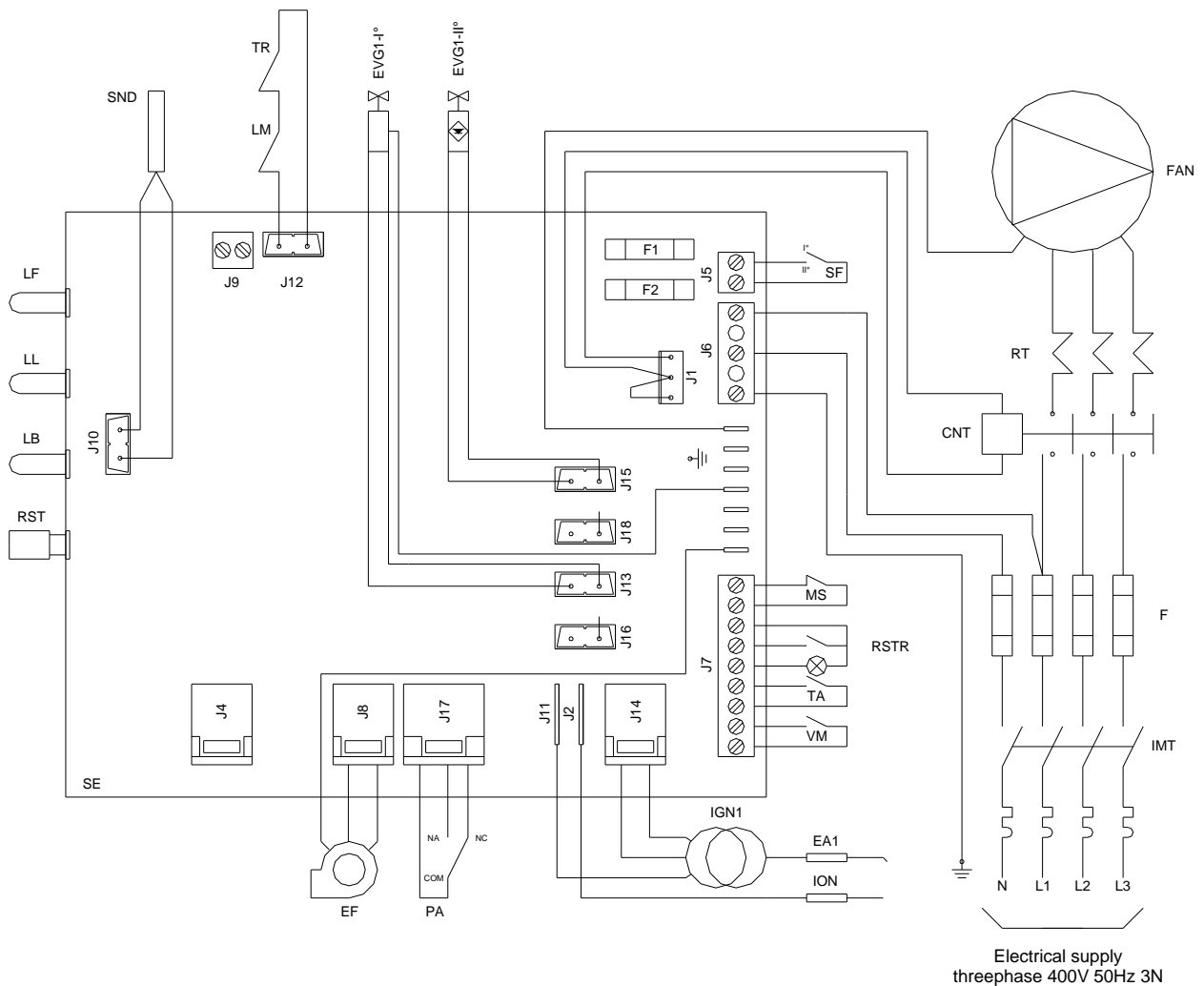

KEY:

| | |
|-----------------|---|
| SND | Temperature control probe |
| TR | Regulatory control thermostat(auto reset) |
| LM | LIMIT thermostat (manual reset) |
| EVG1-I° | Gas solenoid valve |
| EVG1-II° | Gas solenoid min (two stage) |
| C | Capacitor / centrifual fan |
| FAN | Centrifugal fan |
| F1-F2 | Control fuse |
| LF | Green working light |
| LL | High temperature indication |
| LB | Lockout indication |
| RST | Lockout reset |
| EF | Flue venter |
| PA | Differential pressure switch |
| IGN1 | Ignition transformer |
| EA1 | Ignition electrode |

| | |
|-----------------|-----------------------------------|
| ION | Ionisation probe |
| SE | Control panel |
| RT | Relay fan motor |
| CNT | Contactor fan motor |
| F | Line fuse |
| IMT (*) | Fused isolator |
| MS (*) | Fire switch |
| RSTR (*) | Remote reset |
| TA (*) | Room thermostat |
| VM (*) | Fan switch |
| SF (**) | Second stage gas valve connection |

(*) External to heater customer supply.

(**) **Two stage only**, External wiring customer supply.

Heaters type 5-6

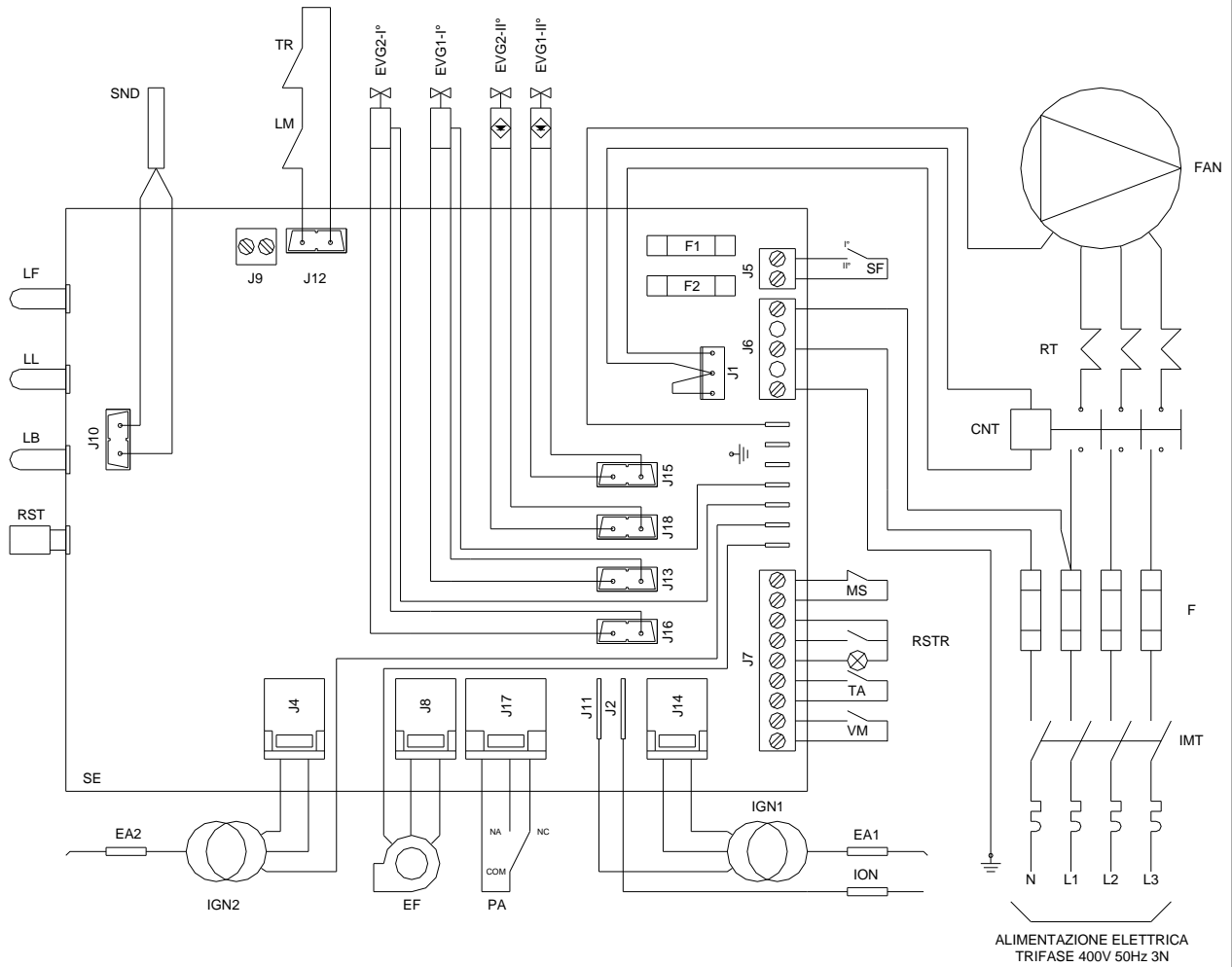

KEY:

| | |
|-----------------|---|
| SND | Temperature control probe |
| TR | Regulatory control thermostat(auto reset) |
| LM | LIMIT thermostat(manual reset) |
| EVG1-I° | Gas solenoid valve 1 |
| EVG2-I° | Gas solenoid valve 2 |
| EVG1-II° | Gas solenoid min 1. (two stage) |
| EVG2-II° | Gas solenoid min2(two stage) |
| FAN | Centrifugal fan |
| F1-F2 | Control fuse |
| LF | Green working light |
| LL | High temperature indication |
| LB | Lockout indication |
| RST | Lockout reset |
| EF | Flue venter |
| PA | Differential pressure switch |
| IGN1 | Ignition transformer 1 |
| IGN2 | Ignition transformer 2 |

| | |
|-----------------|-----------------------------------|
| EA1 | Ignition electrode 1 |
| EA2 | Ignition electrode 2 |
| ION | Ionisation probe |
| SE | Control panel |
| RT | Relay fan motor |
| CNT | Contactor fan motor |
| F | Line fuses |
| IMT (*) | Fused isolator |
| MS (*) | Fire switch |
| RSTR (*) | Remote reset |
| TA (*) | Room thermostat |
| VM (*) | Fan switch |
| SF (**) | Second stage gas valve connection |

(*) External to heater customer supply.

(**) **Two stage only**, External wiring customer supply.

REMOTE CONTROL CONNECTIONS

Connection to CP2A

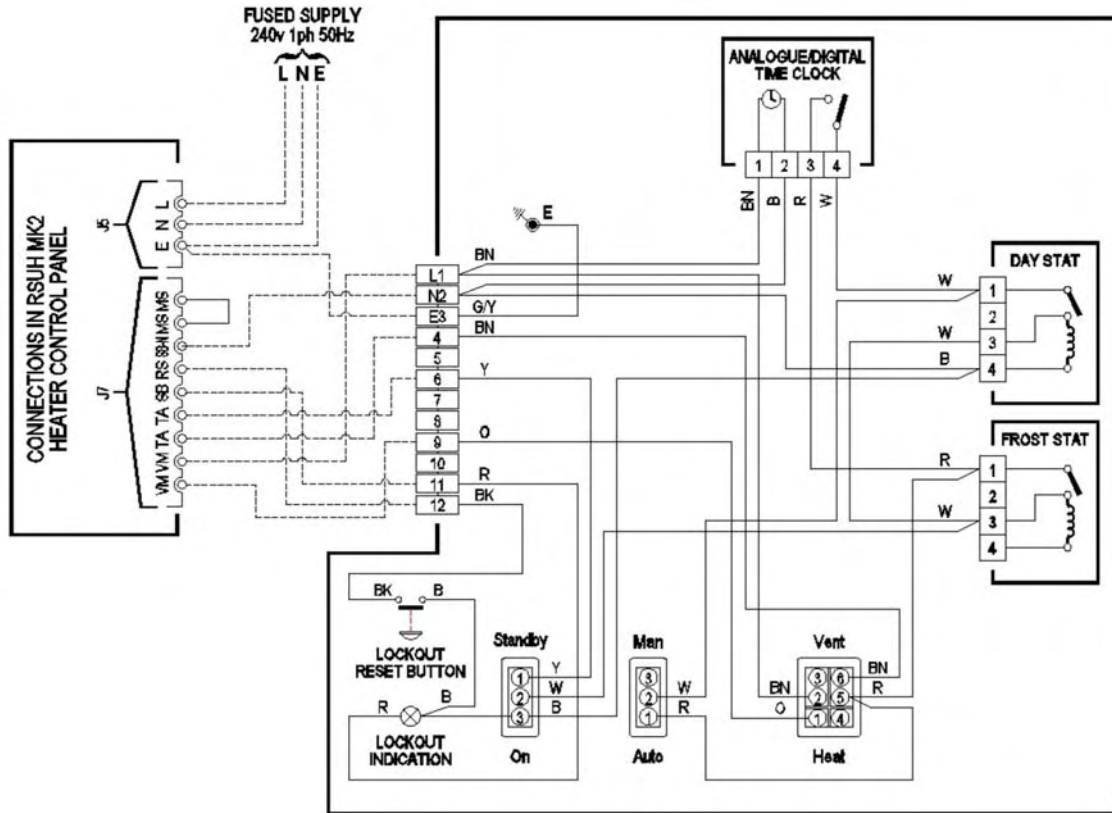

Key:

- | | |
|----------|-----------|
| B Blue | M Magenta |
| BK Black | O Orange |
| BN Brown | P Purple |
| GR Grey | R Red |
| G Green | W White |
| K Pink | Y Yellow |

This wiring to be completed by the installer

! READ THE INSTRUCTION MANUAL BEFORE PROCEEDING WITH THE INSTALLATION

! INCORRECT WIRING WILL DAMAGE THE ELECTRICAL CONTROL PANEL

! THIS HEATER IS NEUTRALLY SWITCHED ENSURE THE WIRING IS CORRECT TO THE DIAGRAMS PROVIDED

OPERATION

To switch ON the heater

- Switch the fused isolator switch ON (supply customer)
- Switch the heater ON/OFF selector to "ON"
- Turn the thermostat to the desired temperature
- The heater will start automatically

To switch OFF the heater

- Turn the thermostat to its lowest temperature setting or alternatively switch the heater ON/OFF selector switch to OFF
- The burner will switch off but the fan will continue to operate for 3 to 4 minutes to cool the combustion chamber before stopping
- Finally switch the fused isolator to OFF

To switch ON fan only

- Switch the fused isolator to ON
- Set ON/STANDBY switch to ON
- Set VENT/HEAT switch to VENT position
- The fan only will run

VERSION SINGLE STAGE

In the single stage version the heater has a standard maximum heat output and a fixed air flow capacity the heater can be operated manually via a switch or automatically by a remote thermostat.

VERSION TWO STAGE

In the two stage version the heater has a two stage high low gas valve and can be operated in either high fire or low fire but with a fixed air flow capacity the heater can be operated manually via a switch or automatically via a remote thermostat.

To switch OFF fan

- Set ON/STANDBY switch to STANDBY

Stop

- Turn the selector switch to STOP

IF HEATER IS TO BE SWITCHED OFF FOR A LONG PERIOD

- Set ON/STANDBY switch to STANDBY
- Isolate at mains electrical supply
- Isolate the gas supply



WARNING! UNLESS IN AN EMERGENCY

Never stop the heater by switching off at the mains isolator. The residual heat accumulated in the heat exchanger may trigger the LIMIT safety device resulting in the need to reset manually.

If this is repeated it will damage the heat exchanger and will invalidate the warranty on the heater.

SERVICING

- Switch the fused isolator switch ON (supply)
- Turn the thermostat to its lowest temperature setting or alternatively switch the heater ON/OFF
- The burner will switch off but the fan will continue to operate for 3 to 4 minutes to cool the heater.

WARNING!

It is a requirement that only qualified personnel are allowed to carry out installation commissioning or servicing. In addition only spare parts recommended by the manufacturer may be fitted, and the installer should provide a list of recommended spare parts that are available through the manufacturer or his agent.

Before commencing any maintenance or servicing work the heater must be shut down and allowed to cool, and have the gas and electric supplies to it turned off at the supply cock and isolator respectively.

Always test for gas soundness after completing any service work particularly if this has necessitated the removal and / or replacement of gas carrying components

It is advisable that routine inspections are carried out on a frequent basis, servicing must also be carried out regularly, and in accordance with the manufacturers recommendations i.e. at a maximum interval of one year. In certain applications the frequency of servicing will have to be increased, this to a large extent is governed by the working environment, and both the manufacturer and the installer will be able to offer further advice.

A safe working platform giving good access to the heater is required.

Clean all accessible surfaces including the outside of the heat exchanger by removal of the fan assembly and the louvres. Check for panel damage and that all fasteners are present and secure.

Visually check all electrical wiring for signs of damage, possibly through contact with hot surfaces, check conduit for signs of chaffing and for security. Check all terminals are secure and free from escaped / stray conductor strands

CLEAN EXTERNAL PANELS

This cleaning should only be carried out with damp cloths with soap and water. In If there are stubborn stains dampen The cloth with a 50% mixture of water and white spirit.

After cleaning dry the surfaces carefully.

CLEANING

Filters should be cleaned regularly as required.

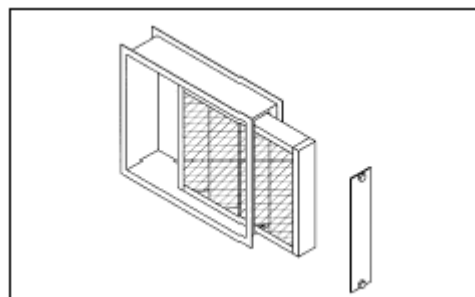

HEATER INDICATOR LIGHTS

If a fault should occur with the heater the lights situated at the right hand side of the heater will be illuminated indicating the fault

- **Red Lockout indication (1).**

This will be illuminated if the heater has gone to lockout due to the loss of flame sensing by the flame probe situated in the burner assembly in order to reset the heater the RESET Button (2) should be pressed (if fitted with remote controls the remote reset button will reset this switch).

- **Yellow overheat indication (3).**

This will be illuminated if the heater has exceeded the temperature set on the thermostat. The thermostat will shut down the burner until the fan(s) have cooled the chamber sufficiently and the burner will re light.

If the yellow light is flashing this means that the heater has gone to overheat and the LIMIT thermostat has operated and shut down the burner The heater will not re light until the LIMIT (4) has been reset this can be done by removing the plastic cap covering the reset button and pushing the reset replace cap

The cause of the overheat should be investigated



RECEIPT OF PRODUCT AND TRANSPORT

Delivery & pre installation checks

The heater is supplied wrapped in heavy duty protective polythene, mounted on a pallet. On receipt of the heater, the following checks should be carried out:

- a) The model is as per order
- b) That it is undamaged
- c) That it is suitable for the gas supply and pressure
- d) That it is suitable for the electrical supply

If any of these points are not satisfied then contact should be made with the Sales Office at Benson Heating In the case of claims for damage this must be reported in writing within 24Hrs of delivery, in order to comply with insurance criteria

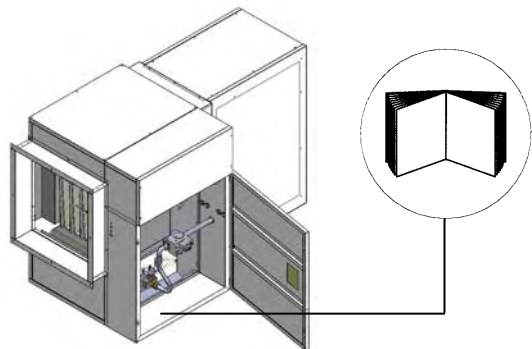

WARNING

The instruction manual is an integral part of the equipment and so, after the packaging has been removed, make sure that it has been collected and stored safely.



When moving the heater ensure that the equipment used is capable of lifting and supporting the weight of the heater
When lifting by fork truck ensure that the forks support the weight

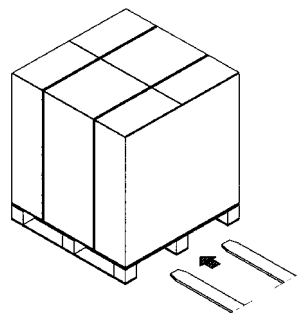

DIMENSION AND WEIGHT

Type 1 – 2 – 3 – 4

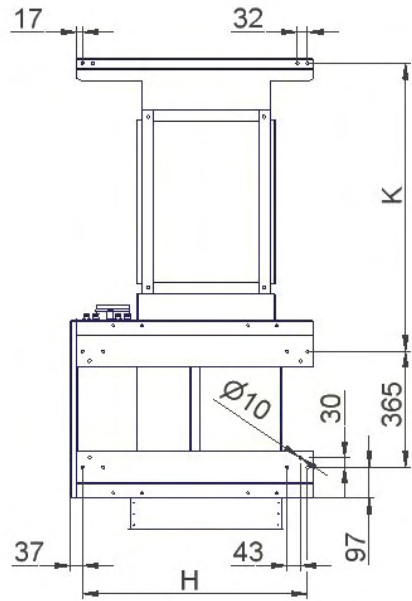

| Type | 1 | 2 | 3 | 4 |
|-------------------------|--------------------|--------------------|--------------------|--------------------|
| A [mm] | 665 | 745 | 925 | 1170 |
| B [mm] | 745 | 745 | 745 | 793 |
| C [mm] | 435 | 515 | 695 | 940 |
| D [mm] | 563 | 563 | 555 | 510 |
| E [mm] | 140 | 140 | 140 | 185 |
| F [mm] | 132 | 132 | 132 | 115 |
| G [mm] | 132 | 132 | 132 | 132 |
| H [mm] | 710 | 790 | 970 | 1215 |
| J [mm] | 335 | 415 | 595 | 840 |
| K [mm] | 910 | 910 | 910 | 960 |
| L [mm] | 1225 | 1225 | 1225 | 1273 |
| Ø1 [mm] | 100 ⁽¹⁾ | 100 ⁽¹⁾ | 100 ⁽¹⁾ | 100 ⁽²⁾ |
| Ø2 [mm] | 100 ⁽¹⁾ | 100 ⁽¹⁾ | 100 ⁽¹⁾ | 150 ⁽²⁾ |
| Ø [bsp] | ½ | ½ | ½ | ¾ |
| Nett weight [kg] | 122 | 133 | 156 | 200 |

(1) female
(2) male

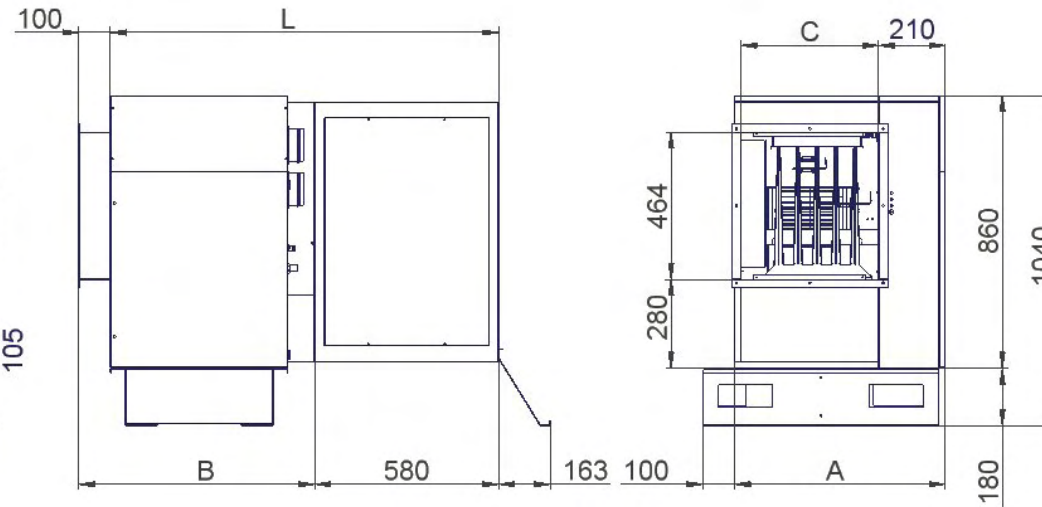
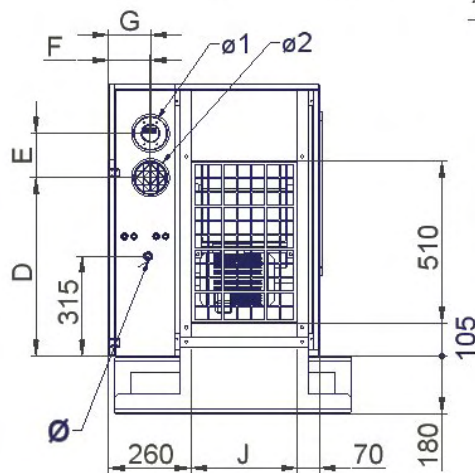

Note: Heater type 5 has two centrifugal fans.

Type - 5 - 6

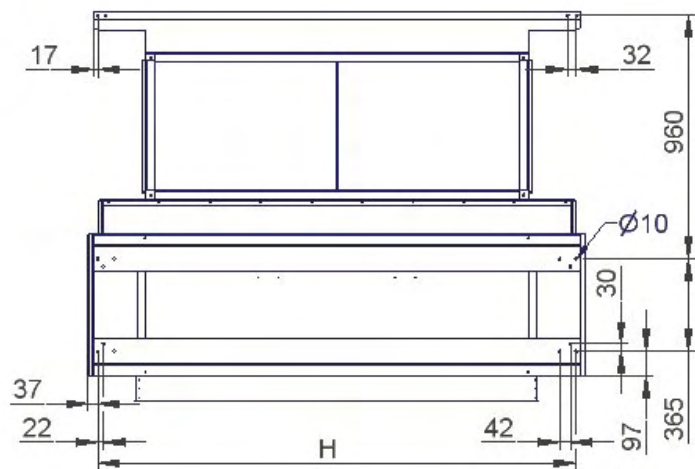

| Type | 5 | 6 |
|-------------------------|---------------|---------------|
| A [mm] | 1720 | 1960 |
| C [mm] | 1300 | 1540 |
| H [mm] | 1640 | 1885 |
| J [mm] | 1200 | 1440 |
| \varnothing [bsp] | $\frac{3}{4}$ | $\frac{3}{4}$ |
| Nett weight [kg] | 267 | 311 |

18

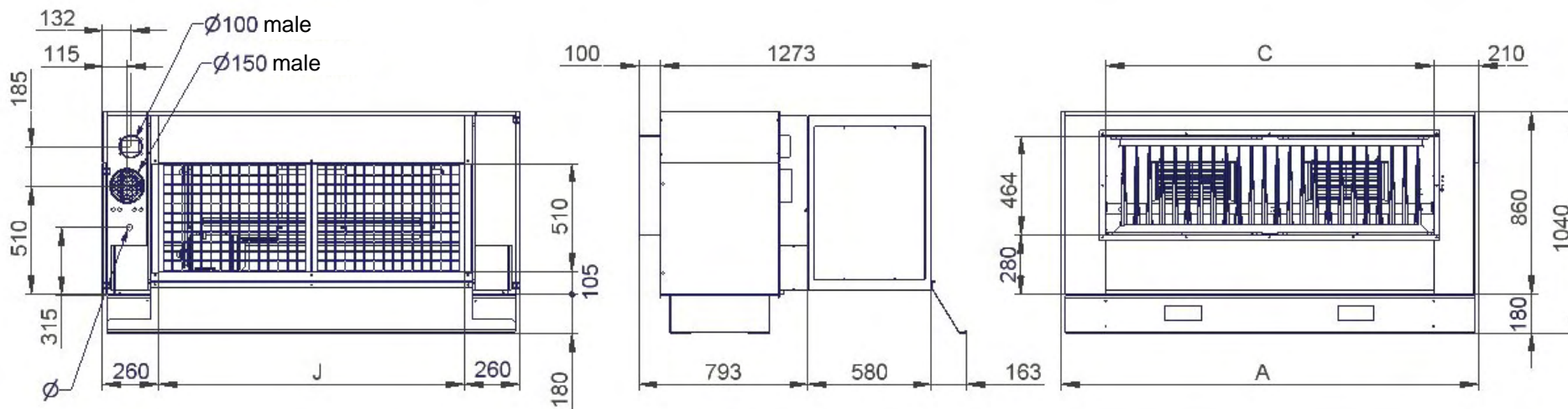

INSTALLATION

It is a requirement that only qualified and competent personnel may undertake installation commissioning and servicing of Heaters.



WARNING

All of the basic criteria must be satisfied prior to commencing installation and commissioning, additionally, the Unit Heater must be positioned and installed so as to comply with all the relevant standards and guide lines as well as meeting national and local fire regulations and insurance criteria, especially if it is proposed that the heater is to be installed within a special risk area (e.g. proximity to where petrol engined vehicles are stored or parked, where cellulose spraying takes place, where woodworking machinery is operated, etc.).

Indirect fired heaters **must not** be located in hazardous areas. However, it is permissible for the heater to supply air to such areas. The heater **must not** be installed within an environment where there is a high concentration of chlorides, fluorides, salts, or other aggressive or volatile chemicals/compounds. Nor should the heater be positioned where the burner could be adversely affected by high winds or draughts.

The heater must be installed so that it is level. Supports for the heater must be sufficiently robust to withstand the weight of the heater and any ancillary equipment. Any combustible material adjacent to the heater or flue system must be so placed or shielded so that its surface temperature does not exceed 65°C

The location chosen for the heater must allow for the fitting of an effective flue system.

The heater must be installed so that it is level, supports for the heater must be sufficiently robust to withstand the weight of the heater and any ancillary equipment. Any combustible material adjacent to the heater or flue system must be so placed or shielded so that its surface temperature does not exceed 65°C. Generally a free blowing heater should be located at a height (measured from floor level to the base of unit)

The location chosen for the air heater must allow for the fitting of an effective flue system. It must also allow adequate clearance for the air supply, return air circulation, gas supply, electrical supply and also provide good service access.

Suspended free blowing Unit Heaters are at their most effective when located as close to the working area as possible. However care should be exercised to avoid directing the discharged air directly onto the occupants of the area to be heated.

Where the passage of cold air causes problems (eg by entrances, loading bays etc) it is considered favourable if the heater is positioned so as the discharge towards or across the cold air source from a distance from 1.5m - 6m dependent upon the size of the entrance and the air throw characteristics of the heater. On exposed walls heaters should be positioned so as to discharge towards, or along the length of the exposed wall.

Where the passage of cold air causes problems (eg by entrances, loading bays etc) it is considered favourable if the heater is positioned so as the discharge towards or across the cold air source from a distance from 1.5m - 6m dependent upon the size of the entrance and the air throw characteristics of the heater. On exposed walls heaters should be positioned so as to discharge towards, or along the length of the exposed wall.



CAUTION

Ensure that the gas service to the appliance carries the correct gas type and that the supply pressure is in accordance with the supply type and pressure stated on the appliance data plate.

Installation, commissioning, and servicing must only be carried out by appropriately qualified and competent persons.



WARNING

Unauthorised modifications to the appliance, or departure from the manufacturers guidance on intended use, or, installation contrary to the manufacturers recommendations may constitute a hazard.

NOTE

To ignore the **warning** and **caution** notices, and to ignore the advice from the manufacturer on installation, commissioning, servicing, or use, will jeopardise any applicable warranty, moreover, such a situation could also compromise the safe and efficient running of the appliance itself, and thereby constitute a hazard. The installation of the appliance must meet all the relevant European, National, and local criteria. Prior to installation the following points should be considered:

- a) The position of the heater for the optimum efficient distribution and circulation of warm air
- b) The position of the heater relative to the route of the flue
- c) The position of the heater relative to the supply of gas
- d) The position of the heater relative to the electrical services, wiring routes, and if appropriate, any additional controls.
- e) The position of the heater relative to the supply of fresh air
- f) The position of the heater relative to potential stratification / circulation problems, which generally occur at higher levels and which may be overcome through the provision of a suitable de-stratification unit.
- g) The position of the heater relative to service and maintenance requirements



CAUTION

The heater **must not** be installed within an area where the conditions are unsuitable, e.g. where the atmosphere is highly corrosive, has a high degree of salinity, or where high wind velocities may affect burner operation. Suitable protection should be provided for the appliance when it is located in a position where it may be susceptible to external mechanical damage from; for example, fork lift trucks, overhead cranes etc.

INSTALLATION CLEARANCES

For the correct operation of heater and for maintenance purposes the following minimum clearances around the heater should be observed

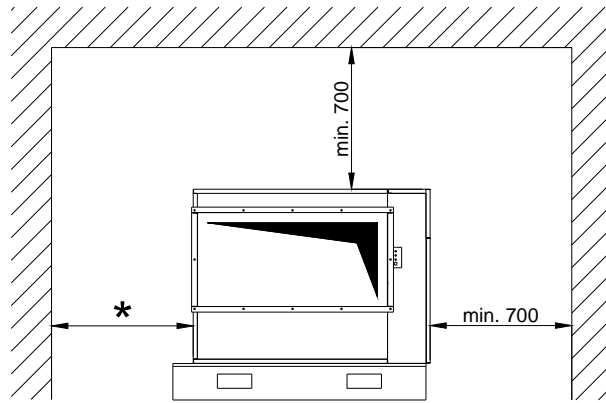

| | |
|---|--|
| * | Minimum 200 mm type 1 - 2 - 3 - 4 |
| | Minimum 700 mm type 5 - 6 |

Heater with warm air duct air inlet from below heater only

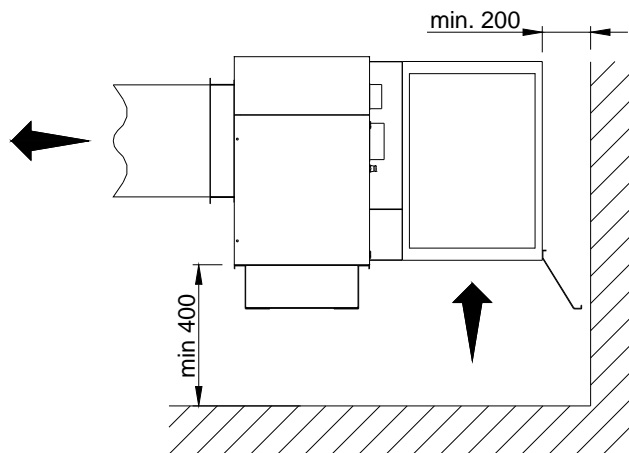

Heater with warm air duct air inlet from rear and below heater.

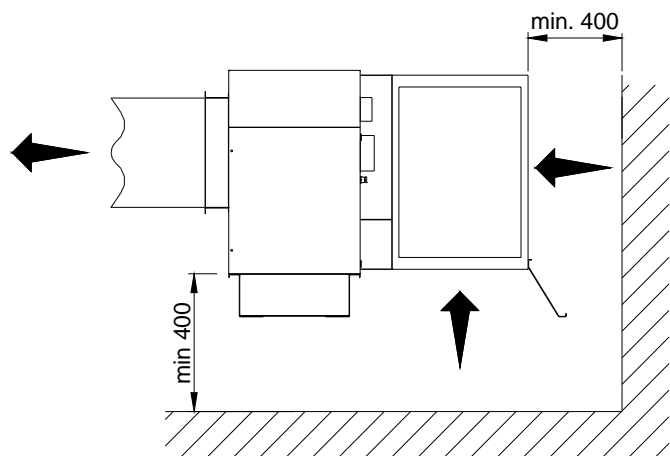

EXAMPLES OF INSTALLATION

Further examples

INSTALLATION:

- Internal installation
- Mounted on wall brackets (1)
- Ducted warm air outlet (2)
- Open return air or ducted (3) from inside the building
- Filter (4) Air Inlet casing (5)

| Type | L |
|------|-----|
| 1÷3 | 360 |
| 4÷6 | 410 |

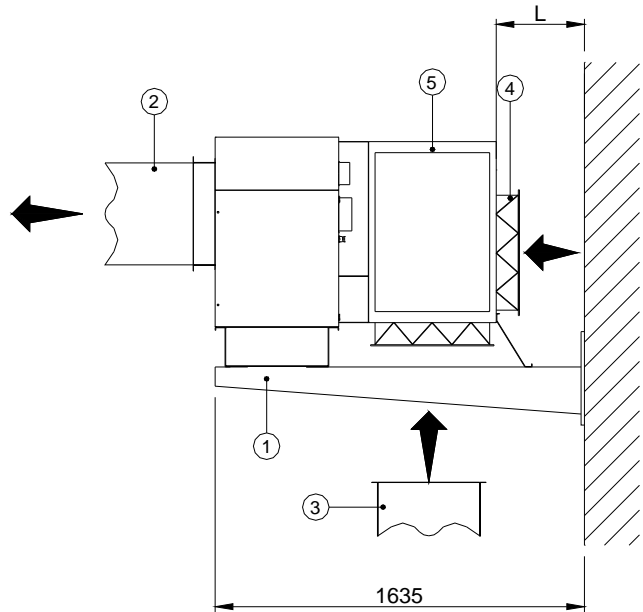

INSTALLATION:

- Internal installation
- Mounted on flat surface or beam (6)
- Ducted warm air outlet (2)
- Open return air or ducted from rear (3)
- Filter (4) Air inlet casing (5)

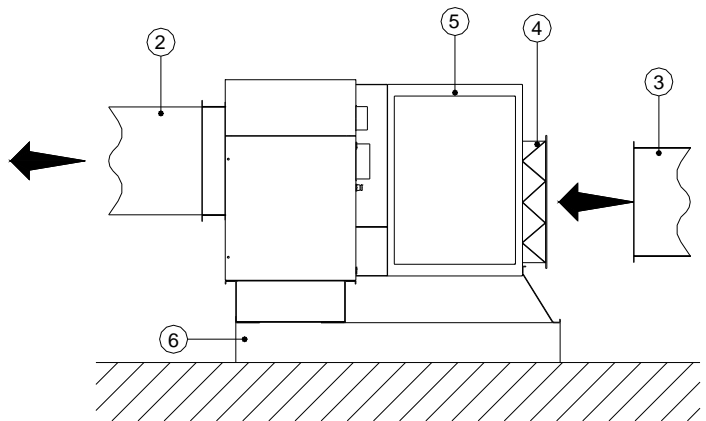

INSTALLATION:

- Internal installation
- Mounted on wall brackets (1)
- Ducted warm air outlet (2)
- Ducted return air from room and external (3)
- Filter (4) Air inlet casing (5).
- Air damper (7)
- External rain proof cowl (8)

| Type | L | L1 |
|------|-----|-----|
| 1÷3 | 360 | 100 |
| 4÷6 | 410 | 50 |

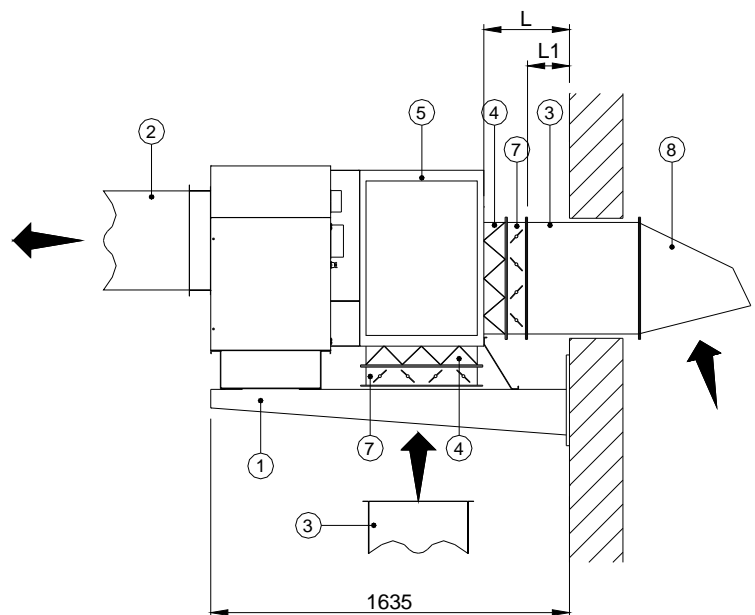

Filters, Air dampers, rain cowl, support brackets are available as accessories .

ACCESSORIES

Available accessories:

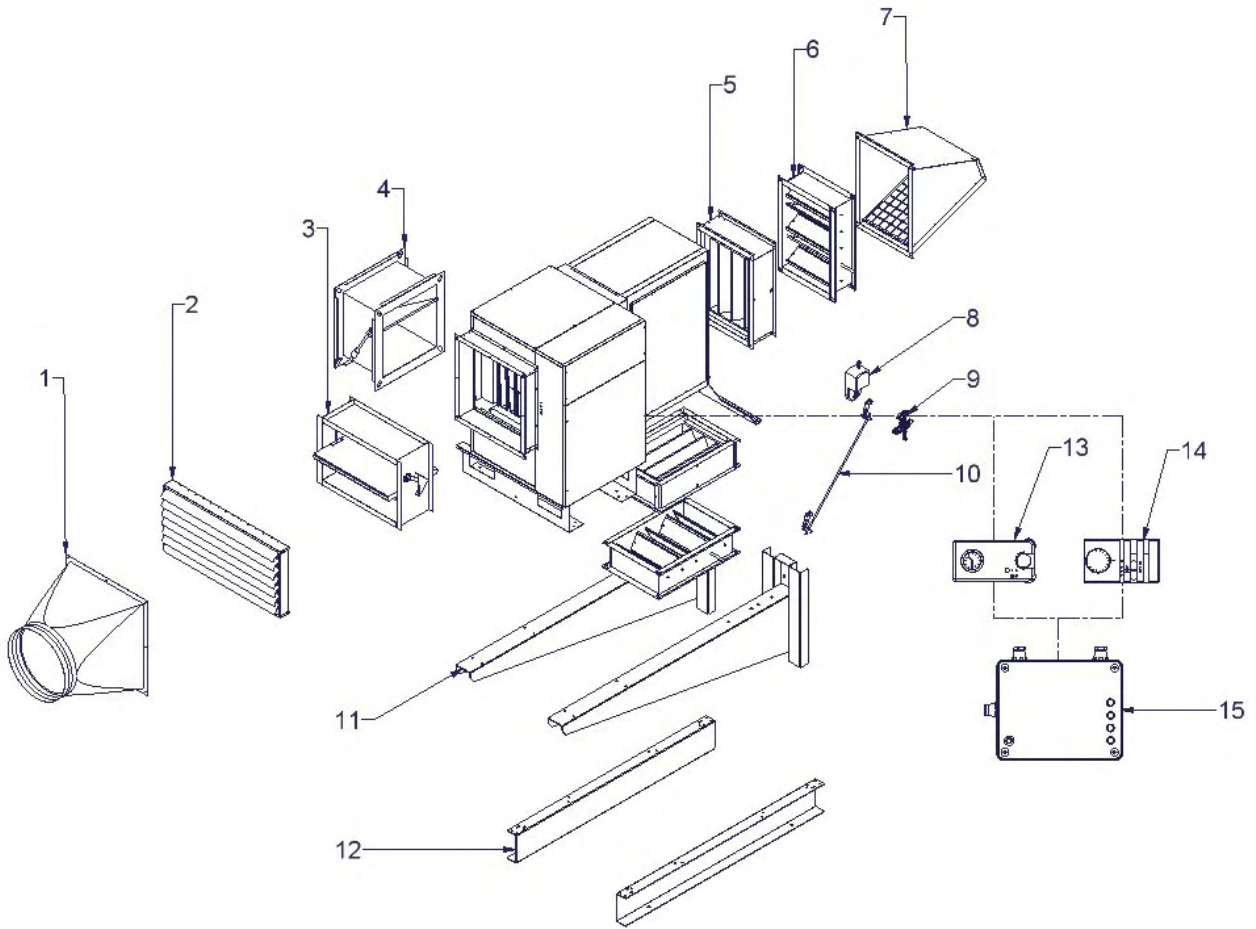

| NO. | DESCRIPTION | TYPE | | | | | |
|-----|---------------------------|------|---|---|---|---|---|
| | | 1 | 2 | 3 | 4 | 5 | 6 |
| 1 | Conical duct connection | ● | ● | ● | ● | ● | ● |
| 2 | Horizontal louvres | ● | ● | ● | ● | ● | ● |
| 3 | Fire damper | ● | ● | ● | ● | ● | ● |
| 4 | Air discharge damper | ● | ● | ● | ● | ● | ● |
| 5 | Air inlet damper | ● | ● | ● | ● | ● | ● |
| 6 | Air filter | ● | ● | ● | ● | ● | ● |
| 7 | Rain proof inlet cowl | ● | ● | ● | ● | ● | ● |
| 8 | Damper motor | ● | ● | ● | ● | ● | ● |
| 9 | Manual control for damper | ● | ● | ● | ● | ● | ● |
| 10 | Control arm | ● | ● | ● | ● | ● | ● |
| 11 | Wall bracket | ● | ● | ● | ● | ● | ● |
| 12 | Support beam | ● | ● | ● | ● | ● | ● |
| 13 | Remote controller | ● | ● | ● | ● | ● | ● |

GAS CONNECTION

Connection of the heater to the gas supply, whether Natural Gas or L P G , must be carried out in compliance with the installation laws and by qualified personnel. The warm air heater is factory set to work with (G20) Natural Gas. A (G31) Propane kit is also available

Before connecting the heater it is necessary to make sure that:

- The correct type of gas for which the equipment has been set up for is available.
- The gas pipes are clean and free from debris .

- The gas supply and meter are capable of delivering the required volume of gas to ensure the correct burner pressure can be achieved See TECHNICAL DATA
- The diameter of the pipework from the isolating cock to the burner must not be less than the diameter of the connection into the multiblock .



An approved gas jointing compound must be used on all joints and unions and the system purged and tested for soundness prior to final connection

Gas Installation

1. **Threaded gas pipe connector** Male 1/2" BSP thread on (type 1-2-3) and 3/4" on (type 4-5-6).
2. **Pressure stabiliser*** (Required to ensure correct gas pressure at valve).
3. **Filter*** (Advised to prevent impurities which may be present in the gas line from entering the gas valve and also to permit simple inspection and maintenance).
4. **Isolating Cock***: Each heater supply must be fitted with a separate isolating cock positioned adjacent to and upstream of the union which must be sited outside the heater the cock should be of the 90° turn type should be clearly marked OPEN/CLOSED and should be installed so as to fall to the closed position.
5. **Gas pipe***

(*)Customer Supply

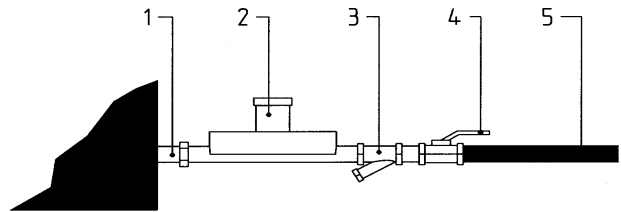

WARNING!

When LPG supply is used it is advisable to install a first stage pressure reducer close to the LPG tank to reduce the pressure to 1.5 Bar and a second pressure reducer near to the heater installation to bring the pressure down from 1.5bar to 40 mbar max. A third reducer (2) mounted in proximity to the heater ensures the correct pressure is provided.

Note

Reference to The Institute of Gas Engineers publications utilisation Procedures IGE/UP1 and IGE/UP2 together with reference to BS6891 is strongly advised

To prevent any problems which could arise due to loss of pressure it is advisable to install a minimum pressure switch to shut down the heater in the event of gas pressure failure.



WARNING!

As there have been recorded instances of the deposition of copper sulphide dust within the valves and orifices of gas appliances as a direct result of a reaction between the hydrogen sulphide contained in some natural gasses and copper pipe we recommend that the heater(s) should not be connected to any natural gas pipe distribution system which utilizes copper pipework, including final connections. Instead steel pipework should be used throughout.

In the event that it is impractical to use steel pipework or where installers are obliged or insist on using elements of copper pipework within the installation then we strongly recommend that the gas supplier be consulted as specific conditions and requirements may be necessary.

FLUE AND COMBUSTION OPTIONS

Room sealed unit heaters are suitable for installation with the following flue configurations : **B₂₂ - C₁₂ - C₃₂** .

Option B₂₂

In this configuration the heater is connected to a single flue pipe to discharge the products of combustion outside the building either through the roof or through a wall

The combustion air is taken from inside the room

- The flue pipe should be metal smooth bored pipe with a diameter of not less than the flue spigot connection on the heater

- All joints should be sealed
- It must be properly secured so as to remain stable at all times
- It must have a wind shielded and rain proof terminal
- The flue should not exceed the length limits indicated in the following pages
- There must be adequate ventilation in the room as per current legislation.

Option C₁₂

In this configuration the heater is connected by two pipes, One discharging the products of combustion and the other bringing the combustion air from outside the building in which the heater is located

The outlet must be through the wall and may be made with two separate pipes or with concentric pipes

- The flue pipe and combustion air inlet should be metal smooth bored pipe with a diameter of not less than both the flue and combustion spigot connections on the heater

- All joints should be sealed
- It must be properly secured so as to remain stable at all times
- It must have a wind shielded and rain proof terminal
- The flue should not exceed the length limits indicated in the following pages
- There must be adequate ventilation in the room as per current legislation

Option C₃₂

In this configuration the heater is connected by two pipes, One discharging the products of combustion and the other bringing the combustion air from outside the building in which the heater is located

The outlet must be through the roof and must be made with concentric pipes

- The flue pipe and combustion air inlet should be metal smooth bored pipe with a diameter of not less than both the flue and combustion spigot connections on the heater

- All joints should be sealed
- It must be properly secured so as to remain stable at all times
- It must have a wind shielded and rain proof terminal
- The flue should not exceed the length limits indicated in the following pages

The following pages show installation diagrams of the above configurations.

B₂₂: Single pipe flue to outside wall or roof terminal. Combustion air from inside building

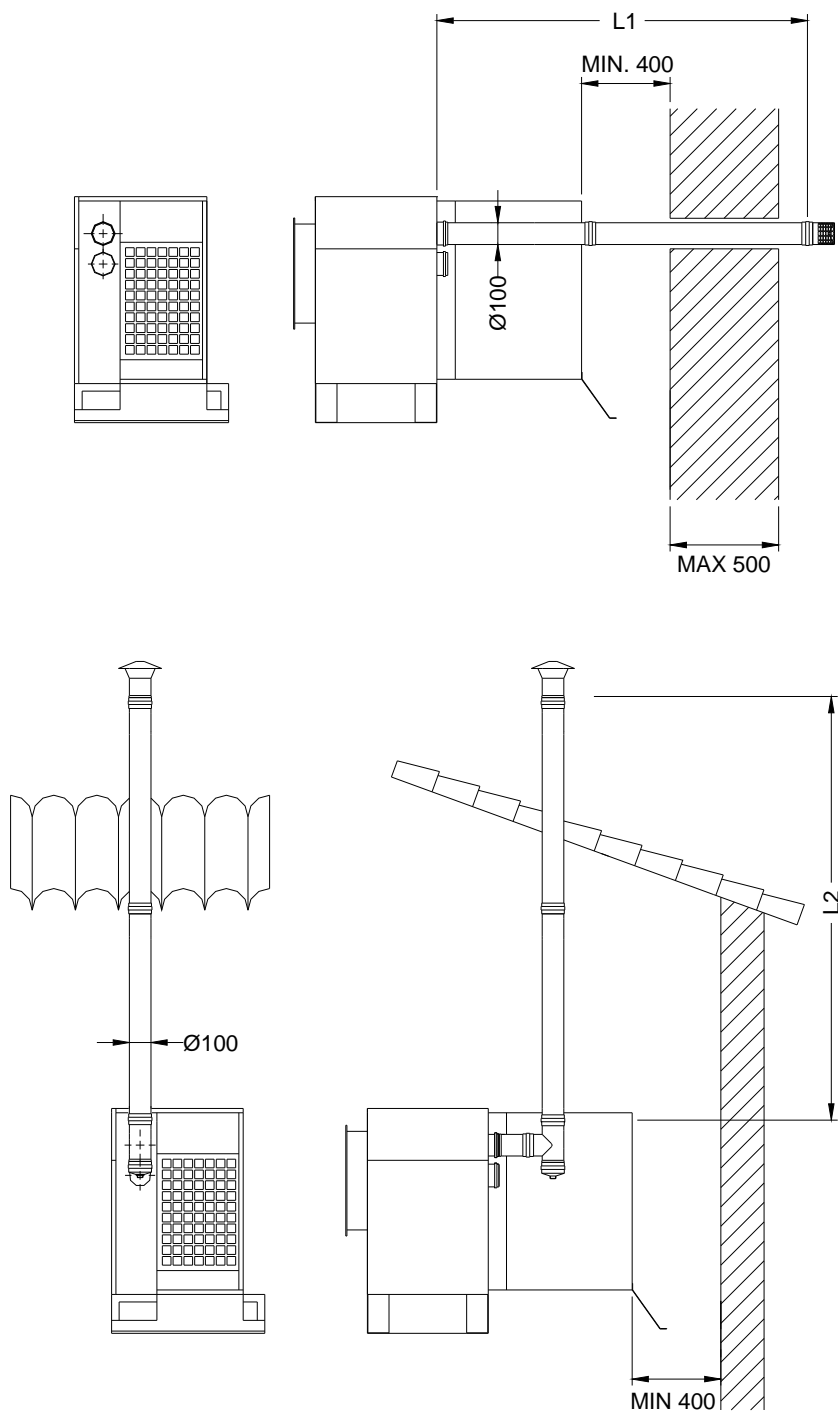

INSTALLATION DISTANCES FOR FLUE PIPE:

| TYPE | UNIT | HORIZONTAL FLUE | | VERTICAL FLUE | |
|------|------|-----------------|---------|---------------|---------|
| | | L1 MIN. | L1 MAX. | L2 MIN. | L2 MAX. |
| 1 | m | 1,00 | 5,00 | 1,00 | 10,00 |
| 2 | m | 1,00 | 5,00 | 1,00 | 10,00 |
| 3 | m | 1,00 | 5,00 | 1,00 | 10,00 |
| 4 | m | 1,00 | 5,00 | 1,00 | 10,00 |
| 5 | m | 1,00 | 5,00 | 1,00 | 10,00 |
| 6 | m | 1,00 | 5,00 | 1,00 | 10,00 |

- Only manufacturers recommended flue must be used
- When designing the flue consideration should be made for entrapment and disposal of any condensate
- Each bend corresponds to between 0,8-1 meter of horizontal pipework
- The flue installation must comply with all the relevant regulations regarding height and position from all openings.

C₁₂: Horizontal flue installation twin pipe and concentric flue terminals.

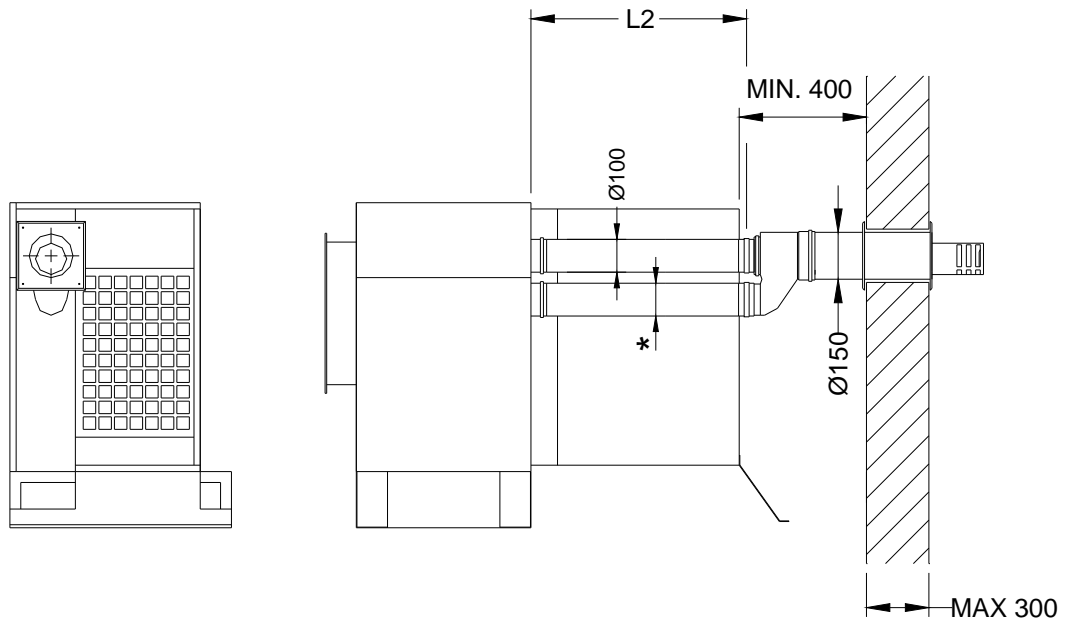
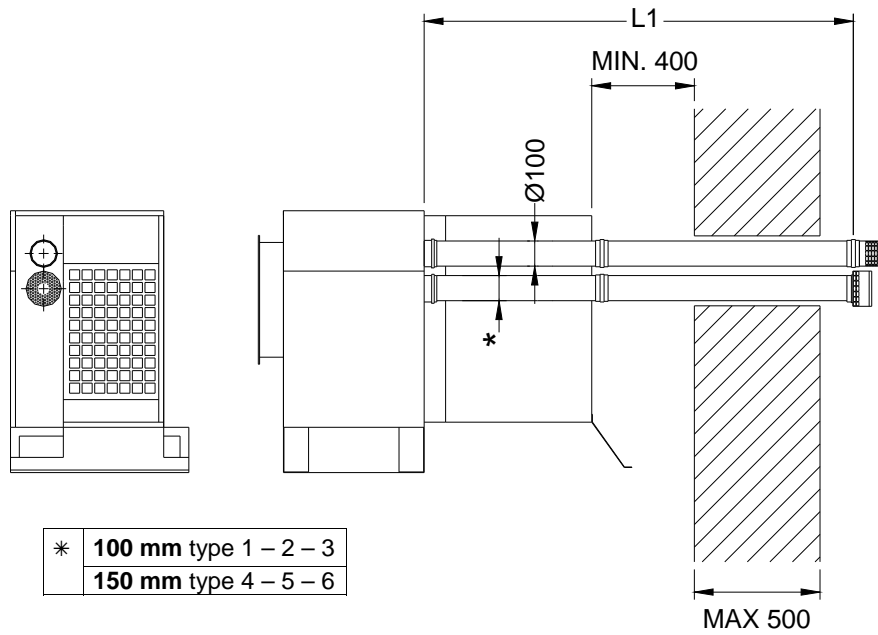

INSTALLATION DISTANCES FOR FLUE PIPE:

| TYPE | UNIT | TWIN PIPE SYSTEM | | HORIZONTAL CONCENTRIC TERMINAL | |
|------|------|------------------|---------|--------------------------------|---------|
| | | L1 MIN. | L1 MAX. | L2 MIN. | L2 MAX. |
| 1 | m | 1,00 | 2,50 | 1,50 | 2,50 |
| 2 | m | 1,00 | 2,50 | 1,50 | 2,50 |
| 3 | m | 1,00 | 2,50 | 1,50 | 2,50 |
| 4 | m | 1,00 | 2,50 | 1,50 | 2,50 |
| 5 | m | 1,00 | 2,50 | 1,50 | 2,50 |
| 6 | m | 1,00 | 2,50 | 1,50 | 2,50 |

- Only manufacturers recommended flue must be used
- When designing the flue consideration should be made for entrapment and disposal of any condensate
- Each bend corresponds to between 0,8-1 meter of horizontal pipework
- The flue installation must comply with all the relevant regulations regarding height and position from all openings

C₃₂ Concentric vertical roof terminal

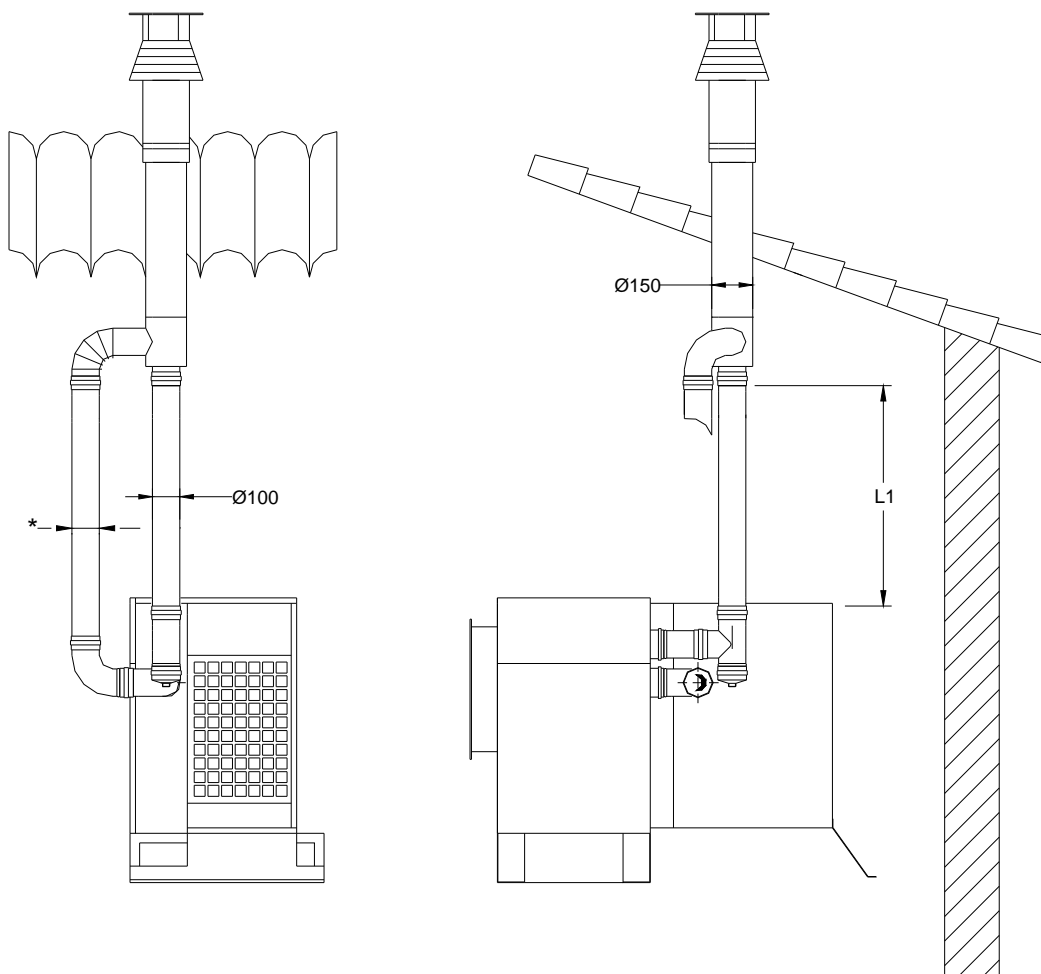

| | |
|---|-----------------------|
| * | 100 mm type 1 – 2 – 3 |
| | 150 mm type 4 – 5 – 6 |

INSTALLATION DISTANCES FOR FLUE PIPES:

| TYPE | UNIT | VERTICAL ROOF TERMINAL | |
|------|------|------------------------|---------|
| | | L1 MIN. | L1 MAX. |
| 1 | m | 0 | 10,00 |
| 2 | m | 0 | 10,00 |
| 3 | m | 0 | 10,00 |
| 4 | m | 0 | 10,00 |
| 5 | m | 0 | 10,00 |
| 6 | m | 0 | 10,00 |

- Only manufacturers recommended flue must be used
- When designing the flue consideration should be made for entrapment and disposal of any condensate
- Each bend corresponds to between 0,8-1 meter of horizontal pipework
- The flue installation must comply with all the relevant regulations regarding height and position from all openings

ELECTRICAL PANEL AND CIRCUIT BOARD

Panel illustrated is fitted to type 5 and 6.

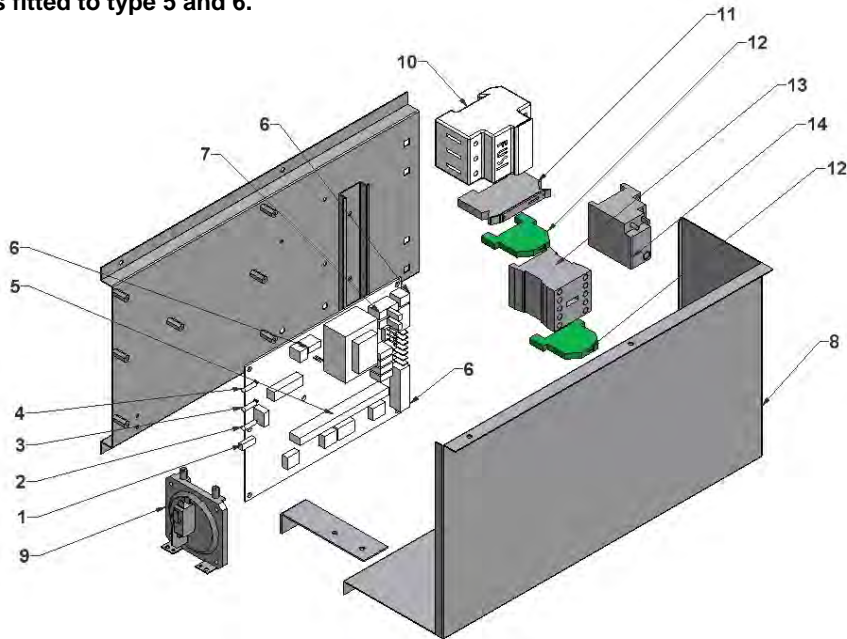

- | | |
|--|--|
| <ol style="list-style-type: none"> 1. Lockout reset 2. Red lockout indication light 3. Yellow temperature indication light 4. Green operating light 5. Flame control circuit 6. Remote connection 7. Line fuse 3.15 Amp | <ol style="list-style-type: none"> 8. Control box cover 9. Differential pressure switch 10. Main fuse (type 4-5-6, 2-3 up rated fan) 11. Neutral fuse (type 4-5-6) 12. Earth connection (type 4-5-6, 2-3 up rated fan) 13. Contactor (type 4-5-6, 2-3 up rated fan) 14. Overload protection (type 4-5-6, 2-3 up rated fan) |
|--|--|

ELECTRICAL CABLE CONNECTIONS

 Only cable sockets provided should be used when wiring heater .

 Care should be taken to ensure that the cables are not exposed to hot surfaces.

 Ensure cables are properly secure

ELECTRICAL CONNECTION

The heaters are supplied with the electric panel fitted and pre wired Connection is required to

- The mains electrical supply
- A room thermostat
- Or accessories such as a remote control panel.

All electrical wiring and connections must be in accordance with the relevant European, National, and local regulations as well as to IEE Standards.

 Ensure that the Electric and gas supplies are turned off before any electrical work is carried out on the heater.

Also ensure that wiring cannot make contact with any metal surfaces liable to be subject to high temperatures, and where insulation of the wiring could be impaired as a result of such contact.

All the heaters must be earthed.

 The main electrical supply must not be switched off or disconnected as a method for stopping the heater, the exception to this is in the event of an emergency, or when the heater has been allowed to cool sufficiently to prevent any

damage from being sustained to the heater or its controls (ie: during servicing).

Claims for damage will not be considered if they have resulted from incorrect wiring or the incorrect use of the heater.

Each heater requires a permanent 230V 50Hz 1ph (415/3/50Hz, Types 5 6) electrical supply, which must be wired through a Fused Isolator fitted with a fuse of the correct rating.

The correct supply connection points for the live, neutral, and earth are clearly indicated on the wiring diagram mounted inside the wiring box cover.

Wiring diagrams are also detailed within this manual.

The electrical supply isolator should be mounted adjacent to the air heater in an easily accessible position to allow for servicing isolation, or emergency shut off.

 **Ensure that the mains isolator is turned OFF before undertaking any electrical on the heater. Access to the electrical panel is gained by opening the right hand heater side panel.**

The cover to the electrical panel can be removed by undoing the screws which secure it to the panel. A copy of the wiring diagram is affixed to the inside of the cover.

Ensure that all connections are secure and that there are no loose strands which could bridge across the terminals.

One electrical panel per heater is required, unless heaters are specified for multiple heater control applications. On no account should more than one heater be connected to a single time switch or thermostat. The only exception to this is when a control panel suitable for multiple heater applications is supplied by the manufacturer, in which case the wiring diagram supplied with the control panel should be read in conjunction with the existing wiring diagram.

Any ancillary electrical items e.g. room thermostats, time switches, remote panels etc, must be wired into the heater electrical circuit in accordance with the diagrams provided.

When external controls operate to switch the heater OFF, power to the heater should remain to allow the fan to continue to operate to sufficiently cool the heater thereby preventing damage to the heat exchanger.

**⚠ WARNING!
THESE HEATERS ARE NEUTRALLY SWITCHED.**

ELECTRICAL TABLE

| Type | Electrical supply (50Hz~) | Power motor (kW) | Fuse (1) (A) | Thermal Relay (A) | Power up rated fan motor (kW) | Fusibili (1) up rated motor (A) | Relay up rated motor (A) | Live Cable (2) (mm ²) | Earth Cable (2) (mm ²) |
|------|------------------------------|---------------------|-----------------|----------------------|----------------------------------|------------------------------------|-----------------------------|--------------------------------------|---------------------------------------|
| 1 | 230V | 0,50 | 6,3 | N.A. | 0,50 | 6,3 | N.A. | 1,5 | 1,5 |
| 2 | 230V | 0,50 | 6,3 | N.A. | 0,75 | 10 | 3,7÷5,5 | 1,5 | 1,5 |
| 3 | 230V | 0,50 | 10 | N.A. | 1,1 | 12 | 5,5÷8,0 | 1,5 | 1,5 |
| 4 | 400V 3N | 0,75 | 10 | 1,8÷2,6 | 1,5 | 10 | 2,6÷3,7 | 1,5 | 1,5 |
| 5 | 400V 3N | 1,1 | 10 | 2,6÷3,7 | 2,2 | 10 | 3,7÷5,5 | 1,5 | 1,5 |
| 6 | 400V 3N | 1,5 | 10 | 2,6÷3,7 | 3,0 | 12 | 5,5÷8,0 | 1,5 | 1,5 |

(1) Included with the heater

(2) The supply cable size should ensure a fall in voltage of less than 5% over a length of 30 meters

DUCT CONNECTION

The heater is supplied with a duct spigot fixing points and dimensions below.

| Type | A | B | N° of fixings |
|------|------|-----|---------------|
| 1 | 435 | 232 | 6+2 |
| 2 | 515 | 272 | 6+2 |
| 3 | 695 | 362 | 6+2 |
| 4 | 940 | 242 | 10+2 |
| 5 | 1300 | 332 | 10+2 |
| 6 | 1540 | 392 | 10+2 |

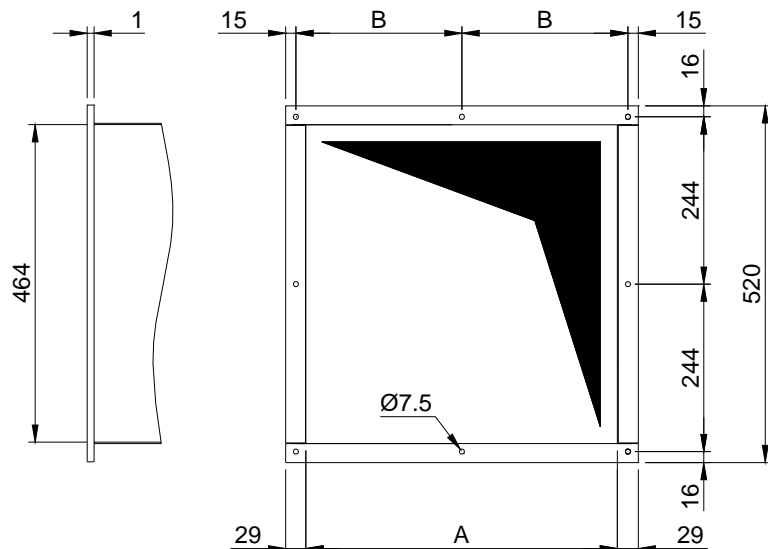

Important:

- A gasket should be provided between the heater flange and the ductwork (not supplied)
- In order to prevent the transmission of vibrations to the ducting a suitable flexible joint is advised
- The ductwork should be suitably supported through out the installation.

- The total resistance in both the inlet and supply ducting should not exceed that given in the TECHNICAL DATA section of this manual .

⚠ The heater should always be connected to ductwork, and not operated as a free blowing unit only a suitably qualified and competent person should size the ductwork.

RETURN AIR CONNECTIONS

The heater is supplied with 2 return air connections one at the rear and one underneath:

- Return air from direction "A";
- Return air from direction "B";
- Return air from both direction "A" and "B".

The heater is supplied with a grille at the rear and a blank panel underneath, both the grille and panel are interchangeable the fixing points and dimensions of the return air plenum are detailed below.

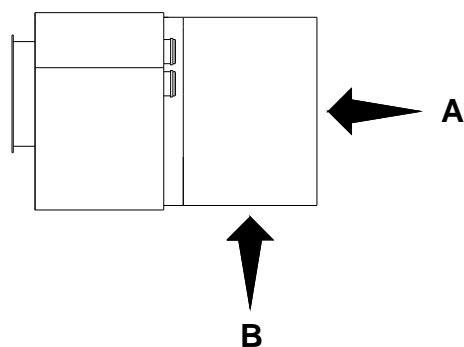

| Type | A | B | N° of fixings |
|------|------|------|---------------|
| 1 | 365 | 335 | 4 |
| 2 | 445 | 415 | 4 |
| 3 | 625 | 595 | 4 |
| 4 | 870 | 840 | 4 |
| 5 | 1230 | 1200 | 4 |
| 6 | 735 | 1440 | 6 |

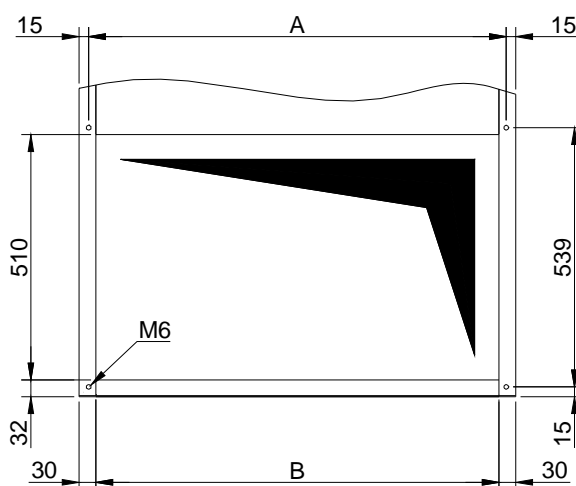

PROTECTION

To prevent any accidental damage or contact with the moving parts of the heater ensure all grilles and panels are securely in place

PRE COMMISSIONING CHECKS

The following pre-commissioning checks should be undertaken, having first ensured that the gas and electrical supplies are turned off.

- Check that all panels and fasteners are secure and in place.
- Check that the heater is mounted safely.
- Check that the flue is sealed, secured, and adequately supported.
- Check that the fan is free to rotate, that the fan motor is secure and that the guards and fan assembly are all in place and properly secured
- Check that the heater is installed so that it is not tilted and remains square.
- Check that the outlet duct resistance is compatible to the data plate .

Once the equipment has been installed, and before it is started up, check the following:

- All the safety conditions have been observed
- The equipment has been suitably positioned
- That the free area around the machine has been respected
- The gas connections have been properly carried out
- The exhaust and intake pipes have been correctly installed
- All the taps for the various circuits are open
- All the electrical connections have been properly carried out

⚠ The may be fumes and odours the first time the equipment is started up, caused by the evaporation of liquid protecting the heat exchanger in storage; this is normal and will disappear after a short time of working. It is advisable to properly ventilate the room.

INITIAL START UP

VENTILATION

- Switch on mains supply to the equipment
 - Set On/ Standby switch to ON
- Set the remote control panel switch to VENT check that fans rotation is correct

HEAT

- Set the remote control panel to HEAT
- Set the room thermostat to the desired temperature
- The flue venter will start, activating the differential pressure switch

After a short period ignition takes place After one minute the air flow fan will start
When desired room temperature is reached the burner will stop the fan will overrun for approximately 3-4 minutes.

IGNITION

- Connect the manometer on the pressure test point on the gas manifold
- Set mains isolator to On
- Open gas isolator cock
- Set the on/standby switch to 'On'
- Set heat/vent switch to Heat
- Set the room thermostat to the desired temperature
- Reset any lockout in the system as indicated by the red or yellow lights.

The flue venter will start up activating the differential pressure switch.

The heater will pre purge the combustion chamber the electronic control box will supply the ignition electrode and the gas valve simultaneously.

If the gas line has not been correctly purged ignition may not take place at the first attempt resulting in lockout of the burner. Reset button and repeat.



Before each attempt at ignition it is necessary to wait at least 10 seconds.

When the burner has ignited check the manometer and, adjust gas pressure setting to pressure indicated on data plate, adjust by turning the solenoid valve screw on gas valve.

- Check the gas consumption reading corresponds with that indicated in the TECHNICAL DATA section.
- Set on/standby switch to 'standby'. When heater is sufficiently cool Isolate electrical supply Isolate gas supply. Remove the manometer and ensure the screw at the test point is tightened to avoid any gas leaks
- Open the gas isolating cock Switch on electrical supply. Set the room thermostat to the desire temperature. The heater is now ready for operation.



WARNING!

The heater must only be operated with the burner compartment door(s) closed

STOPPING

To stop the heater using only the room thermostat Set it to the minimum temperature. Fan will stop after about 3-4 minutes. If required, switch off the mains current at the isolator.



WARNING

If Heater is to be switched Off for a Long Period set ON/STANDBY switch to STANDBY. Isolate at mains electrical supply Isolate the gas supply

Model SIT 840 (SINGLE STAGE)

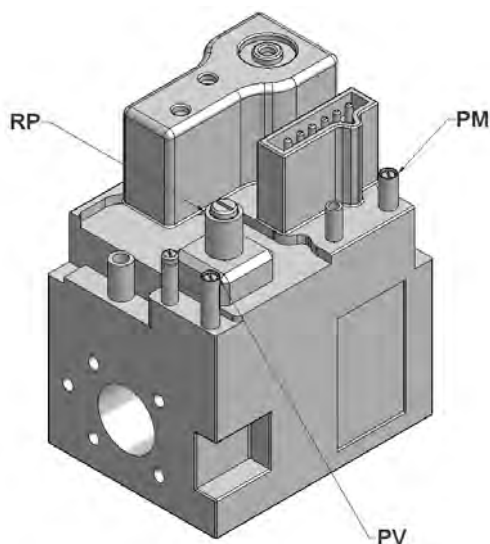

Model SIT 843 (TWO STAGE)

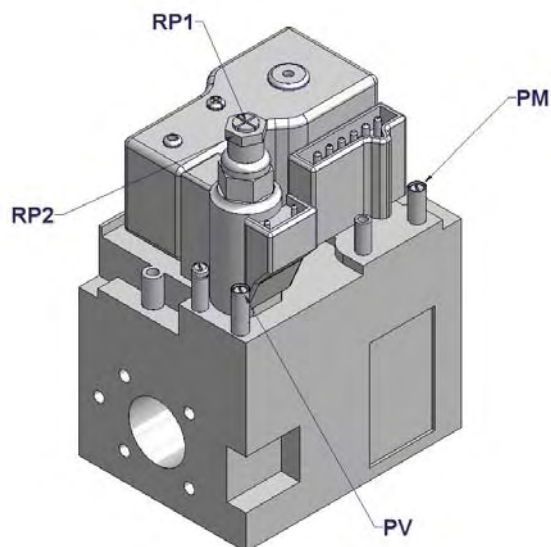

- PM** Main inlet pressure point
- PV** Head pressure test point
- RP** Pressure adjusting screw
- RP1** Cross cut screw low fire adjuster
- RP2** Hexagonal screw high fire adjuster

GAS CONVERSION

The heaters are supplied ready for use with (G20), Natural Gas as per the table below LPG Conversion kits are available from the manufacturer:

Natural Gas (G20)

| TYPE | 1 | 2 | 3 | 4 | 5 | 6 | |
|-------------------------------|---------|------|------|------|------|------|--------|
| Number of injectors | 1 | 1 | 1 | 2 | 2 | 4 | N° |
| Diameter of injectors | 410 | 480 | 555 | 500 | 540 | 450 | mm/100 |
| Gas supply pressure | 20 mBar | | | | | | |
| Head pressure max | 13,0 | 13,0 | 13,0 | 10,0 | 13,0 | 10,5 | mBar |
| Head pressure min (two stage) | 7,0 | 6,5 | 6,5 | 7,0 | 6,5 | 5,0 | mBar |

Before converting the heater to LPG ensure that the gas supply is isolated conversion should be carried out as described in the following section .

INSTRUCTIONS FOR CONVERSION TO PROPANE (G31):

1. Change injectors
2. Adjust to the correct gas inlet pressure
3. Adjust to the correct head pressure
4. Fit primary air diaphragm (if required)
5. Change adhesive label supplied with kit indicating correct gas type
6. Ensure settings are correct as per the manual and data plate.

CHANGE INJECTORS:

To change injectors:

Unscrew the natural gas injectors and replace them with the correct size injectors for propane as shown in the table below:

Propane Gas (G31)

| TYPE | 1 | 2 | 3 | 4 | 5 | 6 | |
|-----------------------|-----|-----|-----|-----|-----|-----|--------|
| Number of injectors | 1 | 1 | 1 | 2 | 2 | 4 | N° |
| Diameter of injectors | 250 | 280 | 335 | 285 | 320 | 255 | mm/100 |

Replacing injectors single manifold (type 1-2-3-5)

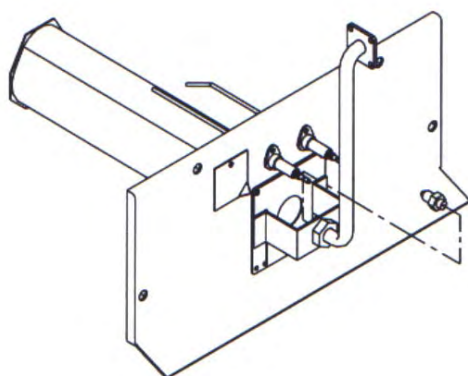

Replacing injectors twin manifold (type 4-6)

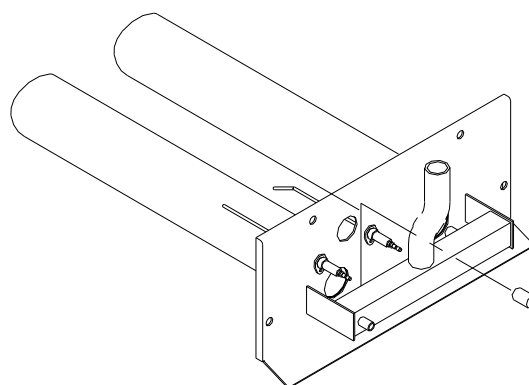

 Check the size stamped on the side of the injector is correct to the data in the manual.

 Ensure that the new injectors are correctly fitted in the manifold and are gas tight. When the conversion is complete affix the adhesive label supplied with the kit indicating the correct gas pressure on to the manifold covering the existing

label completely test for gas soundness on completion.

Ensure that the aluminium washers supplied for types (5-7) are fitted when changing the injectors.

GAS PRESSURE SETTINGS

To regulate the gas inlet pressure :

- Connect a manometer to pressure test point **(PM)**
- Ensure that gas supply pressure is sufficient as detailed the table in the manual provided :

To regulate the head pressure at the injectors:

- Connect a manometer to pressure test point **(PV)**
- Adjust the pressure until it is correct to the data supplied in the following table:

VERSION SINGLE STAGE

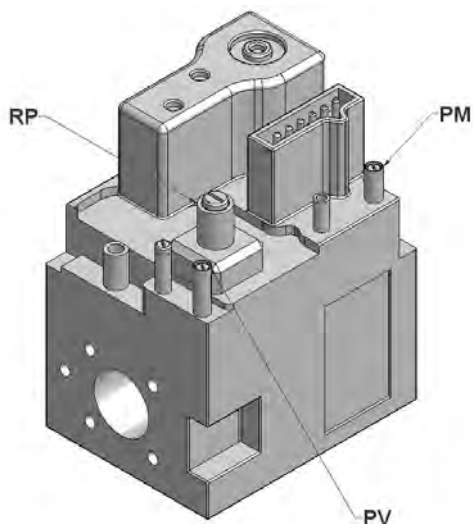

VERSION TWO STAGE

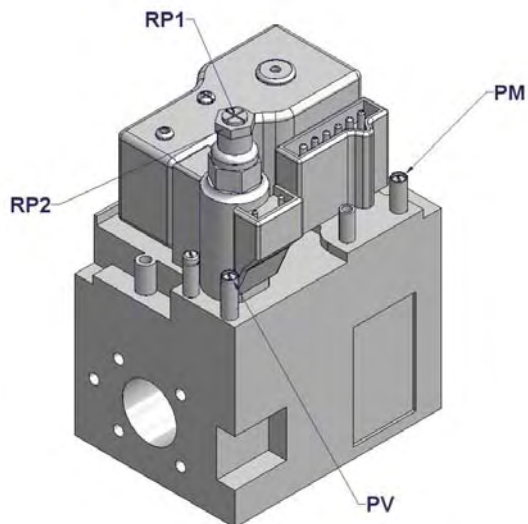

Propane Gas (G31)

| TYPE | 1 | 2 | 3 | 4 | 5 | 6 | |
|-------------------------------|------|------|------|------|------|------|------|
| Gas inlet pressure | 37 | | | | | | mBar |
| Head pressure max | 35,0 | 35,5 | 35,5 | 34,5 | 35,5 | 34,5 | mBar |
| Head pressure min (two stage) | 18,0 | 18,5 | 18,0 | 18,0 | 18,0 | 18,5 | mBar |



Warning gas inlet pressure should not exceed 60 mBar.

SINGLE STAGE

Gas valve regulation Propane G31:

For operation with propane G31 the pressure regulation screw on the valve must be excluded.

To exclude the regulation screw on the gas valve the following procedure should be carried out:

- Remove the plastic cap

- Turn the screw **RP** clockwise to the bottom
- Replace the plastic cap and reseal with paint



For heaters equipped with two gas valves it will be necessary to exclude both valves .

TWO STAGE

Gas valve regulation Propane G31 :

Gas valve head pressure setting high fire Propane G31:

When setting the gas pressure for propane high fire (second stage) contact SF should be closed the high fire pressure adjusting screw on the gas valve must be excluded.

Connect a manometer on test point PV

Remove the plastic cover from the adjuster **RP1 RP2** With a screw driver hold the adjuster **RP1** stationary and using a spanner, screw adjuster **RP2** clockwise to the bottom of the thread until the correct pressure according to the data plate is achieved .

Gas valve head pressure setting low fire Propane G31:

When setting the gas pressure for propane low fire (first stage) contact SF should be open. The low fire pressure should be adjusted to the settings shown on the data plate and the data in the manual provided by adjusting screw RP1

Clockwise increases the pressure. Anti clockwise to decrease the pressure. On completion replace the plastic cover and seal with paint.

Remove manometer ensuring that the test point screw is gas tight.



For heaters equipped with two gas valves it will be necessary to exclude both valves .

Assembly of primary air diaphragm:

Diagram showing the fitting of a primary air diaphragm to single burner manifold (1-2-3-5)

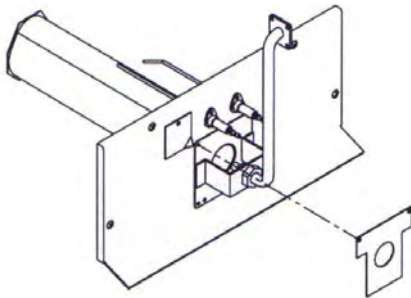
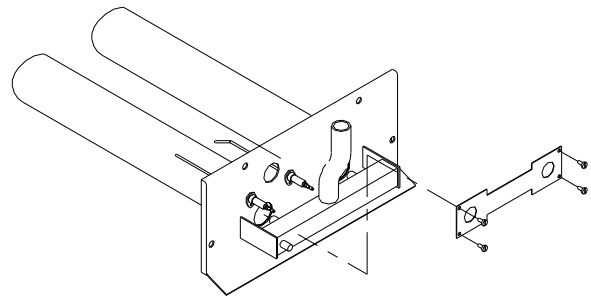

Diagram showing the fitting of a primary air diaphragm for a two burner manifold type (6)



Warning the diaphragm plates should only be used when using propane gas G31.

Gas conversion adhesive label:

Once the heater has been converted to propane ensure that the correct label is fitted to the burner overtop of the factory fitted one covering it completely. It is recommended that the diameter of the nozzles be checked also that the pressure corresponds to that shown on the data plate provided

Ensure that all of the additional gas components are correct for the installation (including storage tank, pipes and pressure valves etc

Ensure that the pressure regulators are sealed after carrying out the conversion.



Gas inlet pressure must not exceed 60 mbar at the gas valve inlet.

THERMOSTAT

The heater is supplied with thermostats to control the FAN operation and LIMIT functions.

• FAN OPERATION (SND)

When the air near the sensor SND reaches the set temperature (30°C) which is approximately 30 seconds after ignition the electrical contact closes and starts the fan.

When the air temperature close to the sensor drops below the set temperature (30°C) and about 3-4 minutes after the burner switches off the fan will stop. This prevents cold air flows when the burner starts and stops.

Fan control SND TR function is connected in parallel through the control box to the fan operation SND

• FAN CONTROL THERMOSTAT (SND - TR)

If the air reaches the set temperature due to a fault in the air circulation (SND – TR) thermostat (70°C), will shut down the burner and the yellow light on the front of the heater will illuminate. Once the heater has sufficiently cooled down the thermostat will reset and the light will go out. Continual operation should be investigated.

• LIMIT THERMOSTAT (LM)

When due to a fault the air temperature near the sensor reaches exceeds the set value and reaches (100°C), the yellow indicator light will flash and the burner will shut down The overheat limit switch will have to be manually reset

FAN

The driven variable pitch pulley drive and fixed fan pulley are factory pre set and are suitable for most applications.

The fan speed can be adjusted on the variable speed pulley to allow for variations in duct resistances inclusion of filters etc.

It will be necessary to check that the temperature rise across the heater is within the tolerance shown in the technical data .

On types 4-5-6 Three Phase heaters, fan rotation should be checked prior to first ignition of the unit. It may be necessary to adjust the motor pulley to achieve correct motor running current as motor plate.

To check electrical absorption of the motor proceed as follows:

- Insert the ammeter on a phase of the general supply line
- Set the appliance to summer ventilation, so as to exclude all other equipment (burner and auxiliary parts)

Read the absorption figure on the ammeter and compare it with the plate data for the motor shown in the TECHNICAL DATA chapter.

Regulation of the variable pulley on the motor

1. Slacken the belt tension by unscrewing screw (5)
2. Remove the belt (1)
3. Loosen grub screw (3) of the mobile part of pulley with a hexagonal spanner (2)
4. Rotate the mobile part of the pulley so as to obtain the pitch line diameter required
5. Lock the grub screw (3) tightly at the hub hollow
6. Mount and tighten the belt (1)

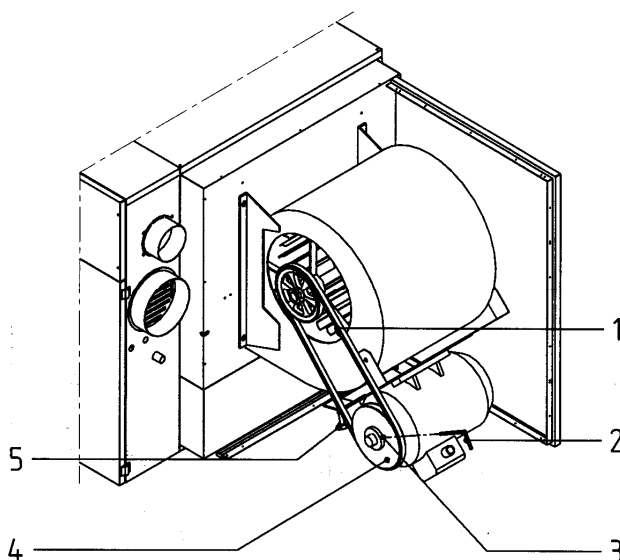

CONTROL

To ensure that the heater is working correctly certain criteria need to be checked . Start up heater and check the following

- Check that the fan starts approximately 30 seconds after ignition of the burner.

When the heater is at its full efficiency after about 20 minutes the following checks should be made:

- Check that the horizontal fins are correctly set so as to give the optimum heating performance and the air flow is sufficient to cool the heat exchanger. ensure where vertical fins are installed they are also open and not restricting the air flow.
- Check that there are no gas leaks
- Check that the gas rate is correct using a meter.
- Check injector pressure is correct.
- Check temperature rise is correct to data plate.

- Check the operation of the control and limit thermostats TR, SND, LM.
- Check that the room thermostat operates the burner not the fan.
- Check that the motor absorption is not more than stated on data plate.
- Check that the relays (type 4 - 5 - 6- and type 2 - 3 up rated fan) correspond to the value on the data plate
- Check that the flue venter and axial fan are working correctly.
- Check that the fan runs on 3–4 minutes after the burner has shut down.
- Check output corresponds to that on the data plate.
- Check that the air flow corresponds to that shown in the data plate and the duct calculations are correct.
- Check that the temperature rise across the heater is as per the data plate
- Check that there is no condensate in the flue gasses.

MAINTENANCE

It is a requirement that only qualified personnel are allowed to carry out installation commissioning or servicing.

Before commencing any maintenance or servicing work the heater must be shut down and allowed to cool, and have the gas and electric supplies to it turned off at the supply cock and isolator respectively.

In order to carry out analyses of the Flue gasses sample points must be made at the following dimensions See Diagram

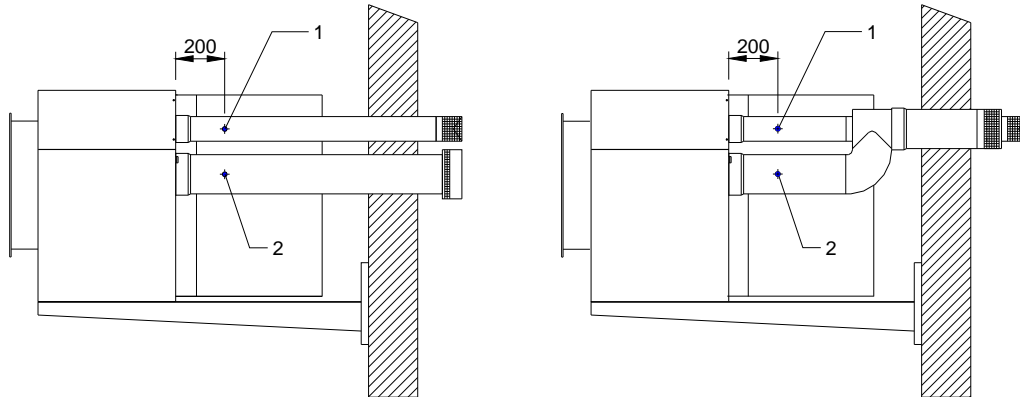

1. Combustion by-product sampling point
2. Combustion air sampling point

•CLEANING OF EXHAUST AND INTAKE DUCTS

The cleaning of the exhaust and combustion air intake ducts consists of the mechanical removal of dust and any foreign substances which may have been deposited internally.

•CENTRIFUGAL FAN MAINTENANCE

Cleaning of the fan consists of the mechanical removal of dust and any foreign substances which may have been deposited on the fan wheel, motor and intake grate. Periodically, check the transmission belt tension and the alignment between motor pulley and the fan pulley.

The belts must not be tighter than is necessary in order to prevent sliding; on pressing the two sides of the belt with hands, the belt must give at least 2-3 cm. To regulate the transmission use the special belt tightening system.

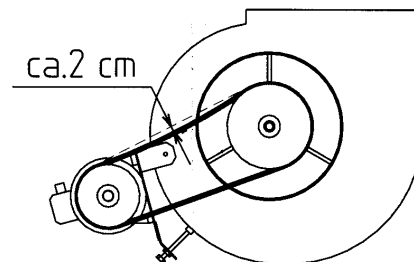

CLEANING OF EXHAUST EXTRACTOR

Cleaning of the exhaust extractor consists of the mechanical removal of dust and any foreign substances which may have been deposited on the fan.

LIMIT THERMOSTAT

Annually, check the LIMIT thermostat is functioning properly, disconnecting the special bridge marked TEST and checking that the burner stops.

CLEANING OF BURNER

Cleaning of the burner takes place by removing it from its housing and removing any scale which may have been deposited on the tubing, using exclusively compressor air or brass brush. Any broken tubes or packing must be replaced.

CLEANING OF HEAT EXCHANGER

Cleaning of the heat exchanger must be carried out by authorized personnel and is governed by specific regulations. As a guideline cleaning should take place at least once a year, at the beginning of the winter. For this operation proceed as follows:

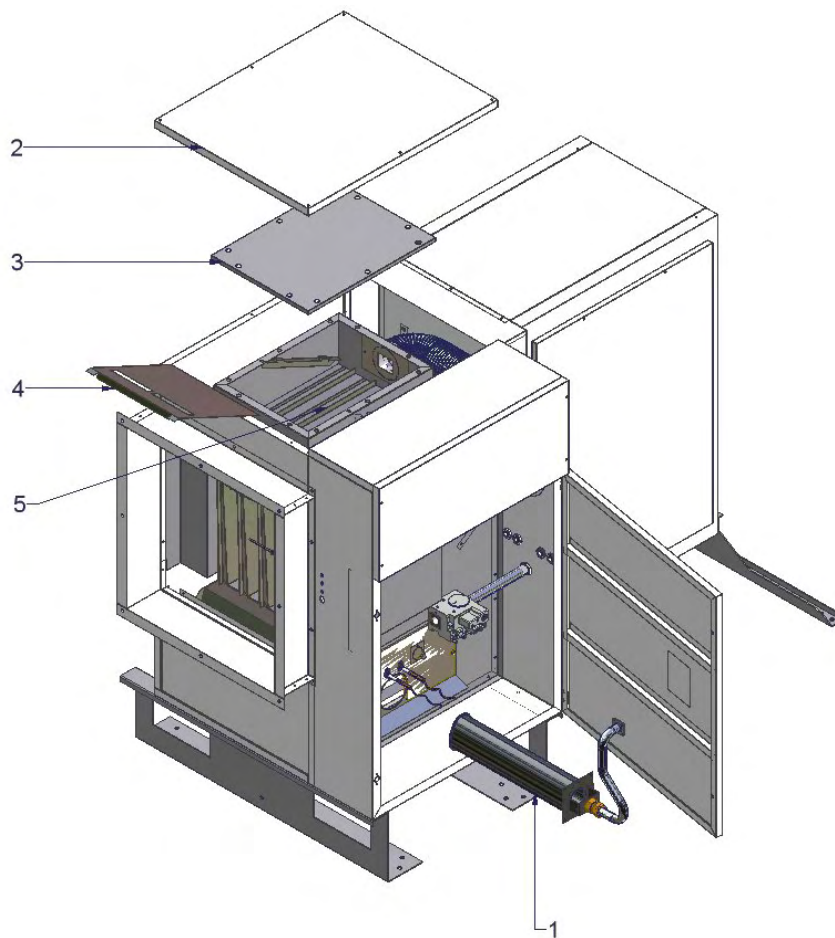

- Remove burner **(1)** from its housing after having disconnected the gas solenoid valve unit;
- Remove upper panel **(2)**;
- Remove inspection door **(3)**;
- Remove conveyor **(4)**;
- Brush the exchange elements **(5)**;
- Remove any soot which may have fallen from the exchange elements into the combustion chamber **(5)**;
- Clean all the external surfaces of the heat exchanger;
- Reassemble everything, paying particular attention to tightness and substituting packing if necessary.

FAULT FINDING

If heater is not working firstly check the following:

- Check electrical supply
- Check gas pressure
- Check gas pressure is as stated in Technical Data

| FAULT | CAUSE | SOLUTION |
|---|--|---|
| No operation | No electrical supply | Check main isolator. Check supply cables. Check line fuses. Check electrical connections |
| No spark ignition. <i>Flue venter working</i> <i>No indication lights on</i> | Differential pressure switch not working | Check flue pipe and combustion air pipe are clear |
| | ▼ Faulty differential pressure switch | ▶ Replace differential pressure switch |
| | ▼ Poor connection at pressure switch | ▶ Check air pipes Check electrical connection Check that the air pipes are condensate free |
| | ▼ Faulty flue venter | ▶ Change flue venter |
| | ▼ Faulty control box | ▶ Change control box |
| | ▼ Faulty ionization electrode | ▶ Check the electrode is not cracked or damaged Check the probe |
| No ignition <i>Flue venter not working</i> <i>No indication lights on</i> | ▶ Room thermostat open | ▶ Check room thermostat |
| | ▼ Faulty flue venter | ▶ Change flue venter |
| | ▼ Faulty control box | ▶ Change control box |
| Burner lights but cuts out after 5 seconds | ▶ Phase and Neutral inverted | ▶ Check polarity of electrical supply |
| | ▼ Faulty ionization probe | ▶ Check electrical connection to the probe. Check probe Change ionization probe. |
| | ▼ Faulty ignition | ▶ Check that the gas type is suitable for heater Check gas pressure Check head pressure. Check gas supply pipes have been purged of air. |

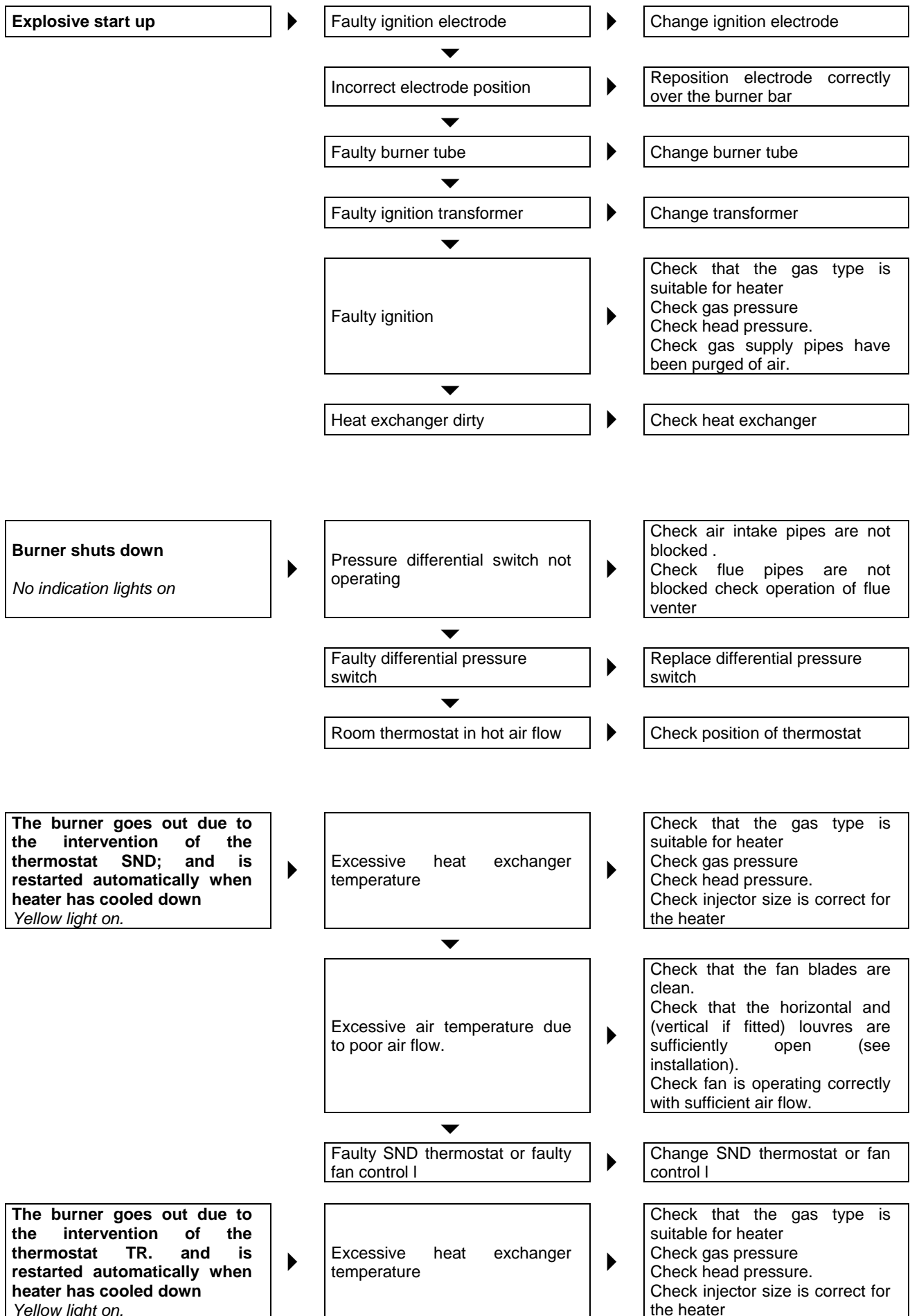

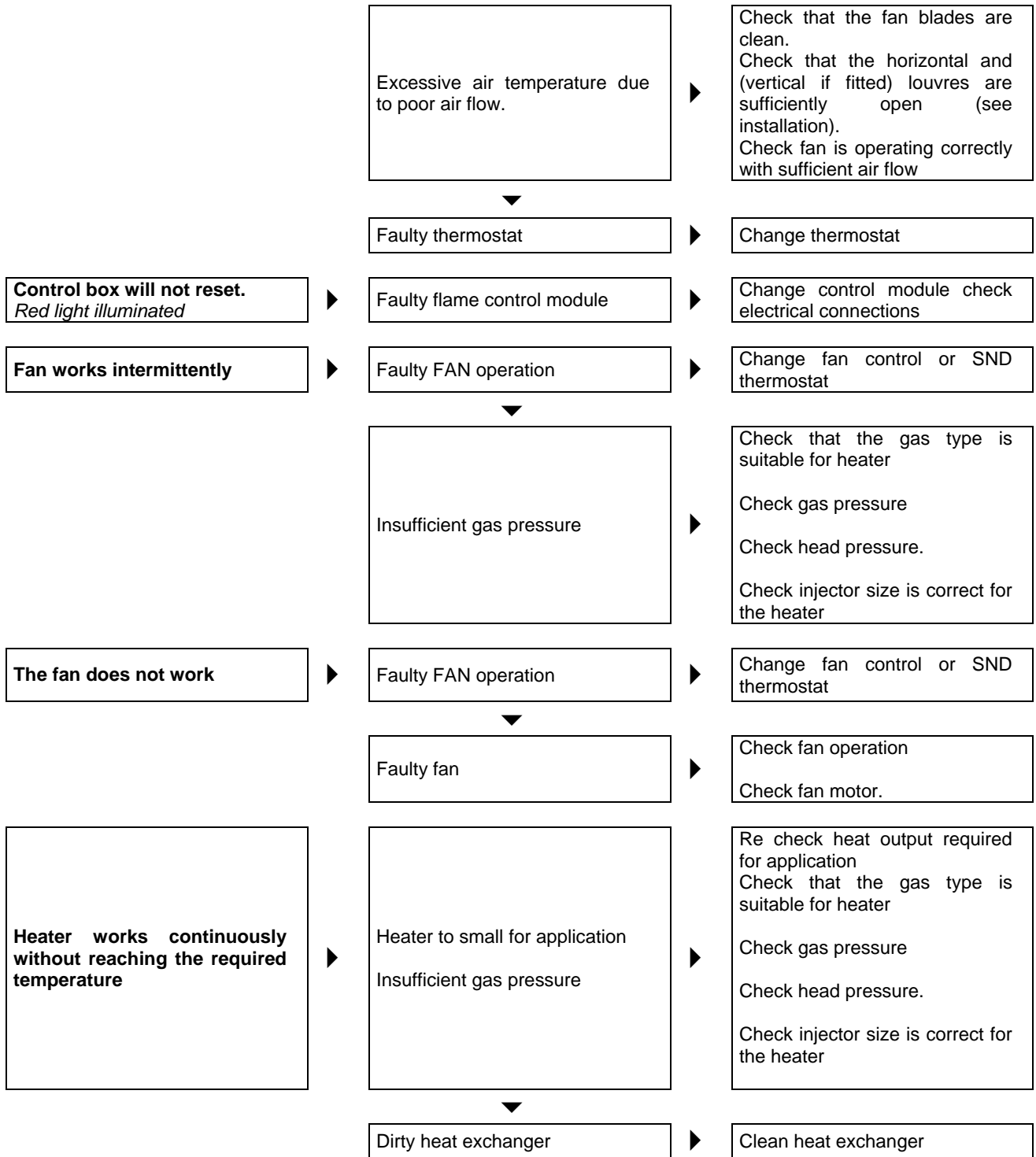



BENSON

BENSON HEATING LUDLOW ROAD KNIGHTON POWYS LD7 ILP

Tel 01547 528534

Fax 01547 520399

www.bensonheating.com

Benson Heating is a Division of Benson Climate Systems Ltd