

# OUH Series

**BENSON  
HEATING**



Oil Fired Unit Heaters

OUHA Axial Fan

OUHC Centrifugal Fan

# OUP Series

## Introduction

The Benson Heating range of oil fired unit heaters is suitable for a wide variety of commercial and industrial applications.

At the heart of these units a high efficiency heat exchanger exceeds the minimum efficiency requirements for UK Building Regulations.

OUPHA units are fitted with a high capacity axial fan for optimum air distribution. The OUPHA 250 - 350 models are fitted with twin fans.

OUPHC models have a centrifugal fan for ducted installations.



## Model Range

The OUP Series oil fired heaters are available in six heat outputs ranging from 31kW to 103kW, for use on 35 seconds oil. Alternatively, units may be specified for use with Kerosene (28 seconds).

## Features & Benefits

- High thermal efficiency 89 - 91% (based on net calorific value) resulting in lower running costs
- Space saving - all units can be either suspended or base mounted thereby freeing up floor space for production or storage requirements
- Simple low installation costs
- Higher efficiency models (100,200,300) are eligible for Enhanced Capital Allowances

## Optional Equipment

A range of options are available. These include:

- Stainless steel heat exchanger
- Hi/lo burner
- Combustion air adaptor
- Remote control panel complete with summer fan only facility
- Vertical louvres and downflow nozzles
- Wall brackets
- Mixing box and filters (OUPHC only)

## ECA



This symbol verifies that models 100, 200 and 300 have been independently assessed and qualifies for the ECA scheme, an upfront tax relief enabling businesses that invest in energy-saving equipment to claim 100% first-year capital allowances against their taxable profits.





## Specification

### Heat Exchanger and Burner

The high efficiency heat exchanger is designed for both long operational life and to have minimal resistance to airflow through the unit.

### Air Distribution

Powerful axial fans fitted on OUHA models provide optimum air distribution via horizontal outlet louvres.

OUHC units are designed primarily for ducted applications and are fitted with centrifugal fans and a duct spigot outlet. A fan box plus optional dampers is also available on OUHC models.

### Cabinets

Cabinets are constructed from electro zinc coated steel panels, finished in epoxy polyester powder coated paint.

### Safety Controls

To ensure safe automatic operation, each unit is fitted as standard with comprehensive safety controls and flame monitoring. To prevent against insufficient airflow a limit thermostat is fitted which shuts down the heater in the event of overheating.

## Installation

Units may be suspended or alternatively mounted on a suitable non-combustible support. Four M10 suspension points are provided to each heater.

Each heater is supplied with a loose fire valve and oil filter. An additional oil fire valve should be installed external to the building where required in accordance with BS 5410:Part2:1978.

A single phase electrical supply is required to each unit. This supply should not be switched off except for maintenance.

An optional rear spigot connection can be provided when ducted combustion air to the burner is required.

Units must not be installed in atmospheres containing highly flammable or explosive vapours, combustible dust, halogenated hydrocarbons or chlorinated vapours. They are also unsuitable for areas where contaminants may affect electrical motors or connections.

## Applications

- Factories
- Greenhouses
- Warehouses
- Workshops
- Showrooms



## TECHNICAL DATA

New Model Ref		OUH 30	OUH 40	OUH 60	OUH 70	OUH 90	OUH 100
Old Model Ref		OUH 100	OUH 140	OUH 200	OUH 250	OUH 300	OUH 350
Nominal heat output	kW	31	40	59	73	88	103
ECA listed		Yes	No	Yes	No	Yes	No
Airflow	m <sup>3</sup> /h	3240	3672	5760	6840	8784	9468
Temperature rise	K	29	32	30	31	30	32
Throw <sup>1</sup> (OUHA)	m	21	23	31	37	36	39
Static pressure (OUHC)	Pa	150	150	180	150	180	180
<b>Fuel Consumption</b>							
Fuel consumption (35 secs)	l/h	3.5	4.5	6.5	8.0	9.7	11.6
Fuel connection	Rc	3/8"	3/8"	3/8"	3/8"	3/8"	3/8"
<b>Electrics</b>							
Supply	V/ph/hz	230/1/50	230/1/50	230/1/50	230/1/50	230/1/50	230/1/50
Electrics FLC (OUHA)	amps	1.6	1.6	2.8	2.8	3.4	4.8
Electrics FLC (OUHC)	amps	8.0	8.0	11.0	11.0	15.0	15.0
Recommended mounting height <sup>2</sup>	m	2.0 - 3.2	2.0 - 4.0	2.4 - 5.0	2.4 - 5.0	2.4 - 5.0	2.4 - 5.0
Noise level <sup>3</sup>	dB(A)	61	65	68	69	71	72
<b>Net weight</b>							
Axial (OUHA)	kg	116	116	177	177	240	240
Centrifugal (OUHC)	kg	138	138	212	212	280	280

1 Throw is dependent on mounting height, building height, room temperature and louvre settings.

2 Recommended height to underside of heater for standard horizontal discharge units. For buildings over 4 metres high, air re-circulation fans are recommended in conjunction with the heaters.

3 Noise levels measured at 3 metres from appliance for OUHA models

## DIMENSIONS

Old Model Ref	OUH 30	OUH 40	OUH 60	OUH 70	OUH 90	OUH 100
New Model Ref	OUH 100	OUH 140	OUH 200	OUH 250	OUH 300	OUH 350
A	780	780	780	780	980	980
B	1050	1050	1475	1475	1750	1750
C	895	895	895	895	1025	1025
D (flue diameter)	125	125	150	150	175	175
E	755	755	1177	1177	1365	1365
F	17	17	17	17	17	17
G	640	640	640	640	770	770
H	20	20	20	20	20	20
J	36	36	36	36	36	36
K	183	183	170	170	231	231
L	340	340	340	340	405	405
M	1175	1246	1175	1175	1376	1376
N	212	212	212	212	300	300
P	139	139	139	139	219	219
R (duct outlet OUHC)	729	729	1151	1151	1339	1339
S (duct outlet OUHC)	730	730	730	730	930	930

OUHA Axial Fan

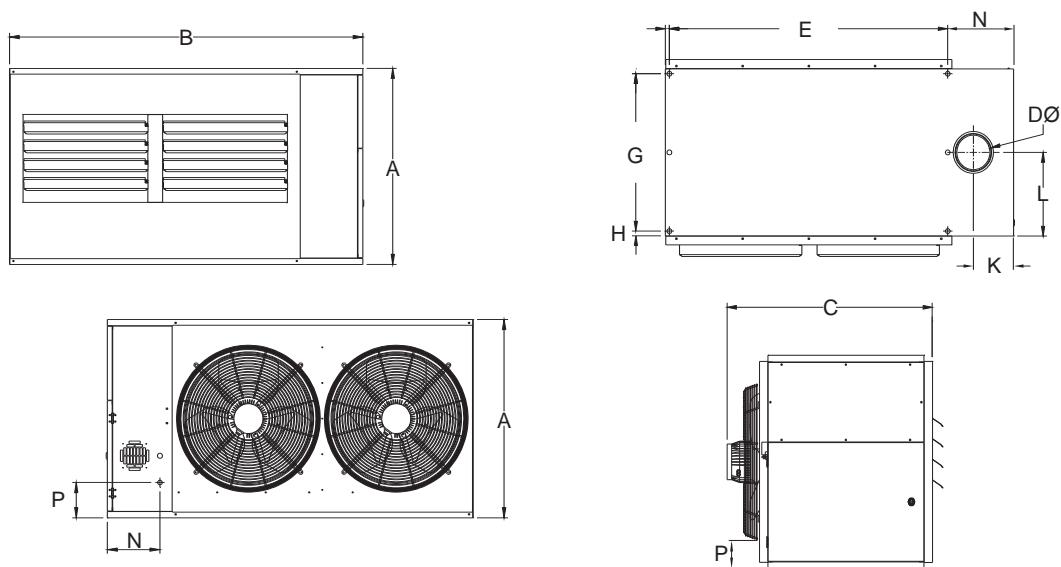

OUHC Centrifugal Fan

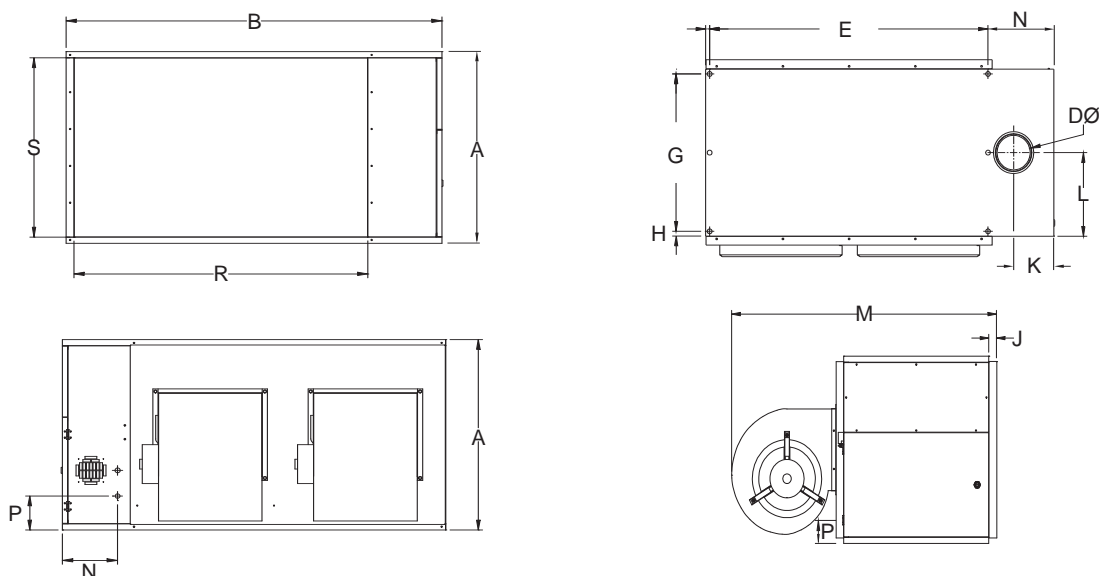

GB/BEN/005/1210



Benson Heating, Ludlow Road  
Knighton, Powys, LD7 1LP  
United Kingdom

Telephone 01547 528534  
Facsimile 01547 520399  
E-mail sales@bensonheating.co.uk  
Website www.bensonheating.co.uk



Benson Heating Ltd is a registered trademark of AmbiRad Limited. Because of continuous product innovation, Benson Heating reserves the right to change product specification without due notice.