

WIRING DIAGRAM MANUAL FOR BENSON EVRC EXTERNAL HEATER



WARNINGS

Installation of Benson Equipment must be carried out in accordance with the current IEE wiring regulations (BS 7671), BS 6896 (Industrial & Commercial) and any other relevant British Standards and Codes of Practice by a qualified installer. All external wiring **MUST** comply with the current IEE wiring regulations.

Wiring Diagrams - ERVC External Unit Heaters

Wiring Diagram 33-67-684 EVRC 12-42 Auto ignition On/Off

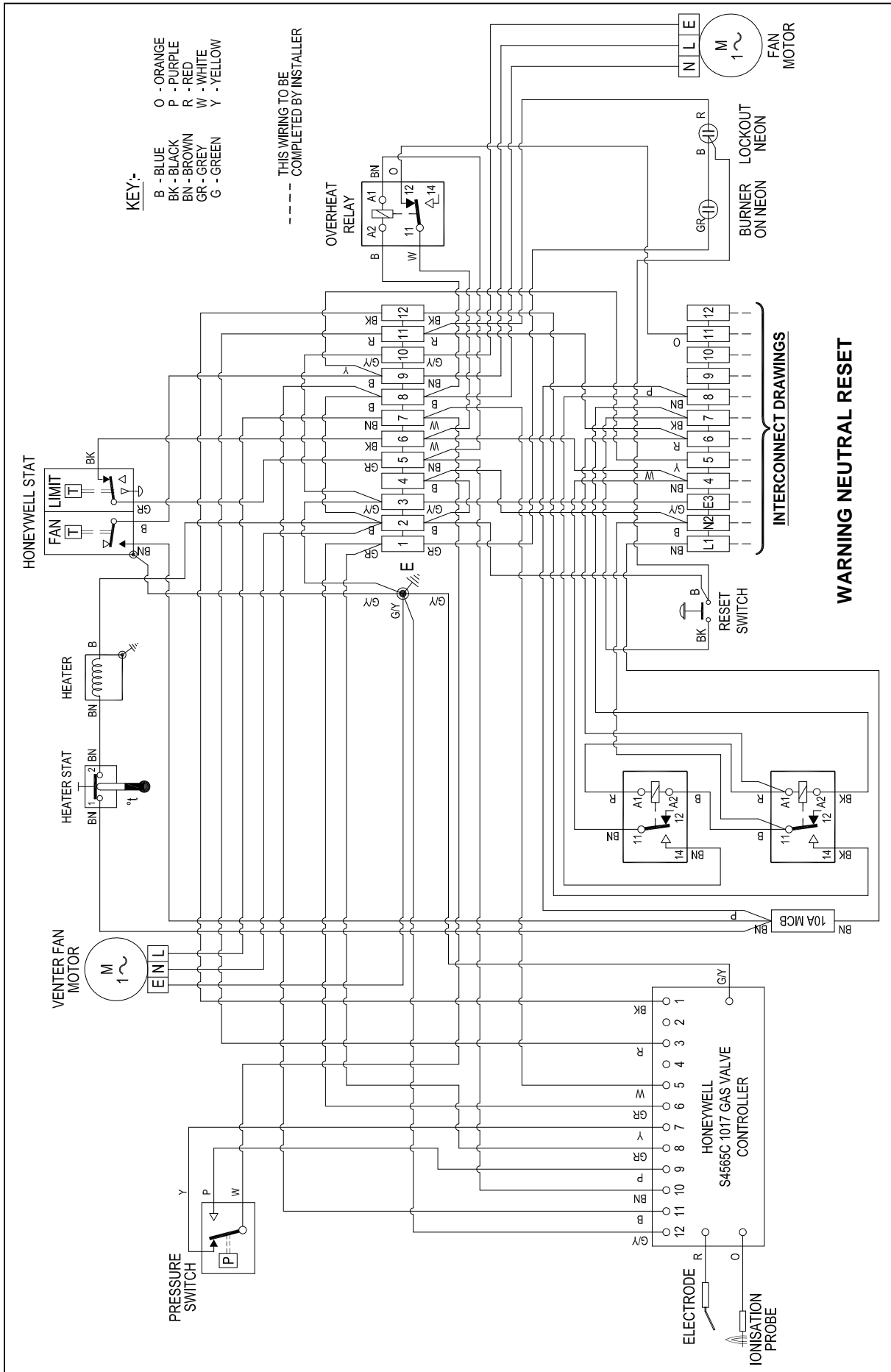

Wiring Diagram 33-67-248 EVRC 50-60 Auto ignition On/Off

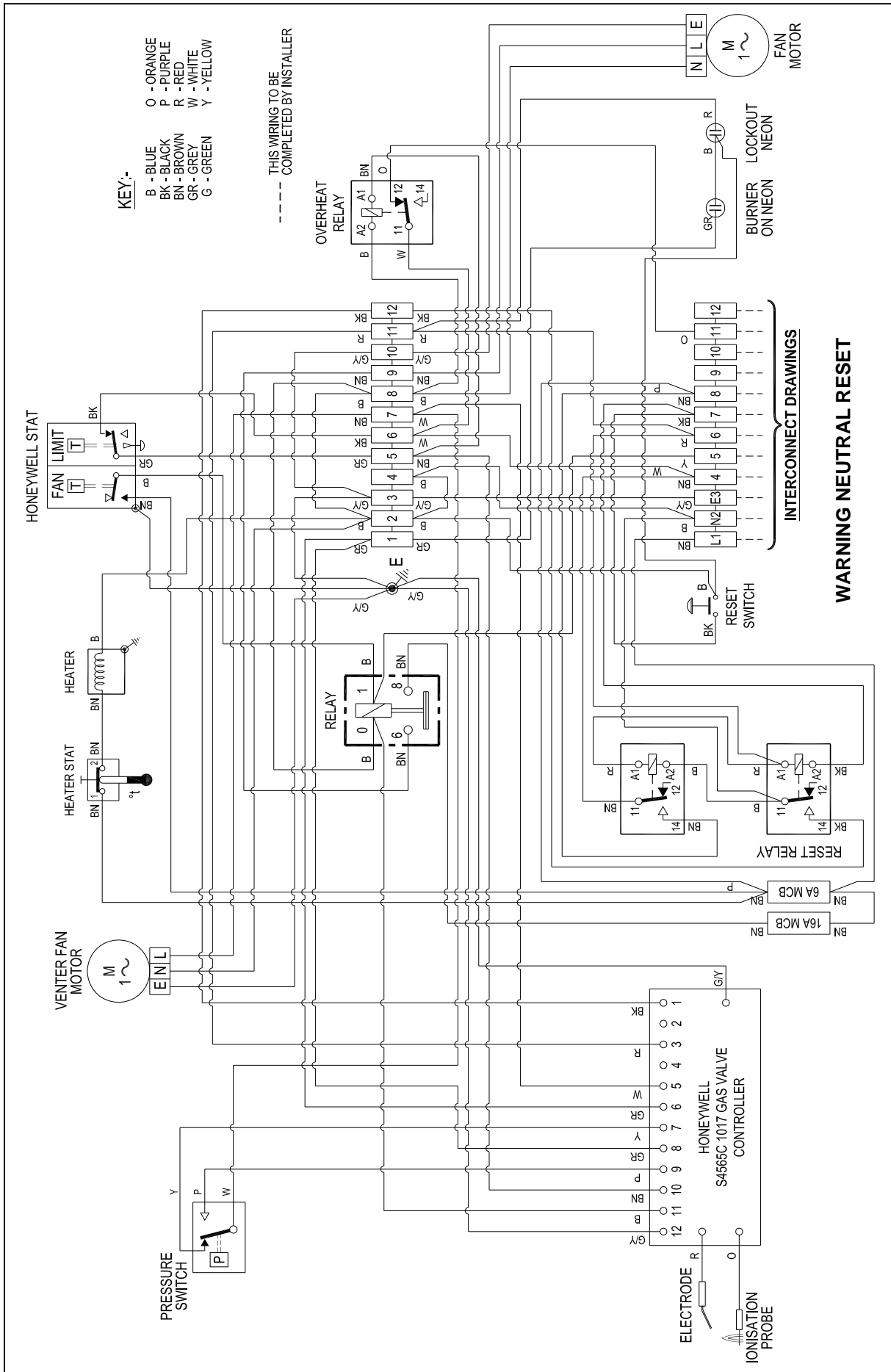

Wiring Diagram 33-67-110 EVRC 50-60 3 Phase Auto ignition On/Off

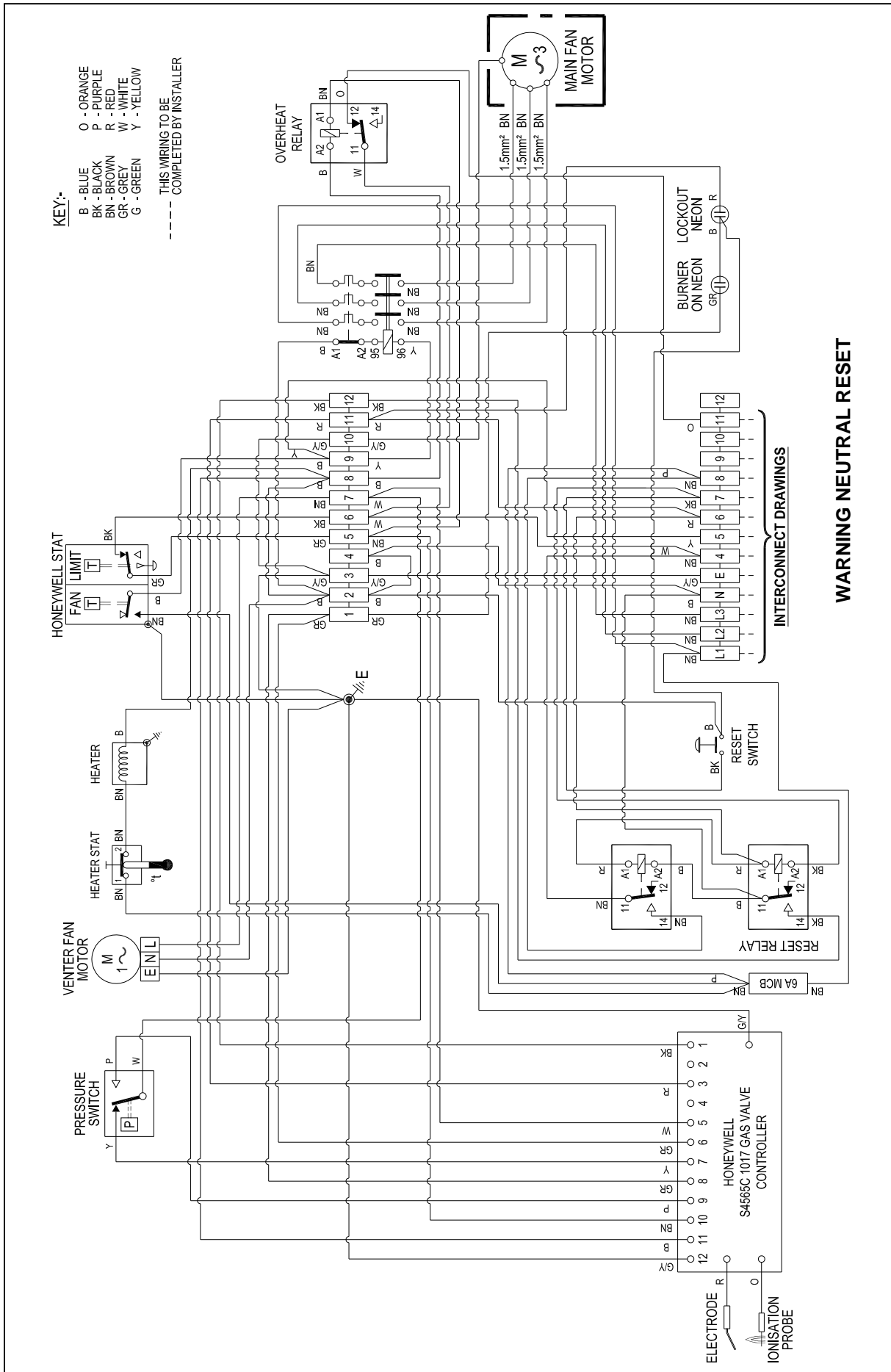

Wiring Diagram 33-67-393 EVRC 72-95 Auto ignition On/Off

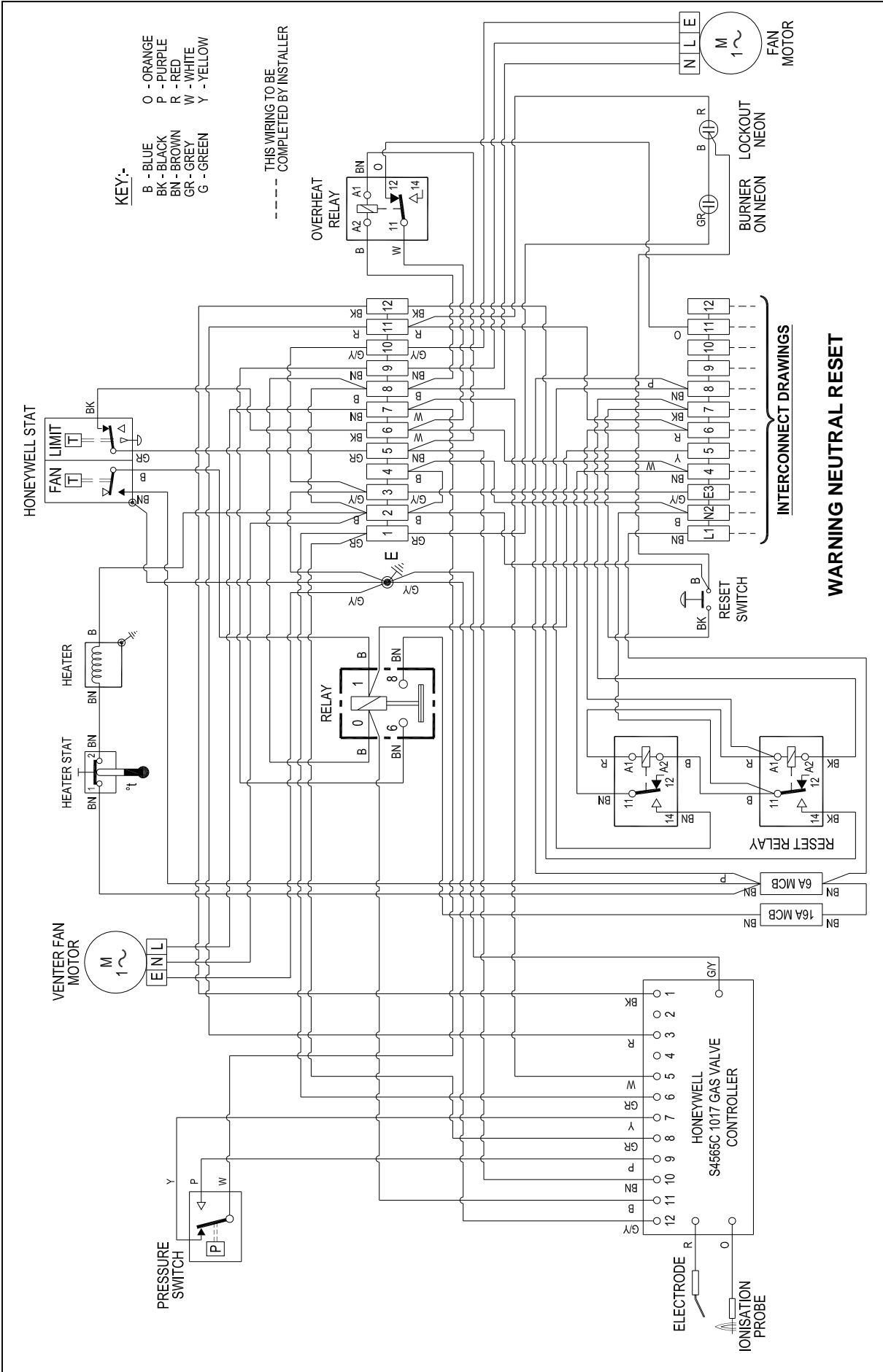

Wiring Diagram 33-67-111 EVRC 72-95 3 Phase Auto ignition On/Off

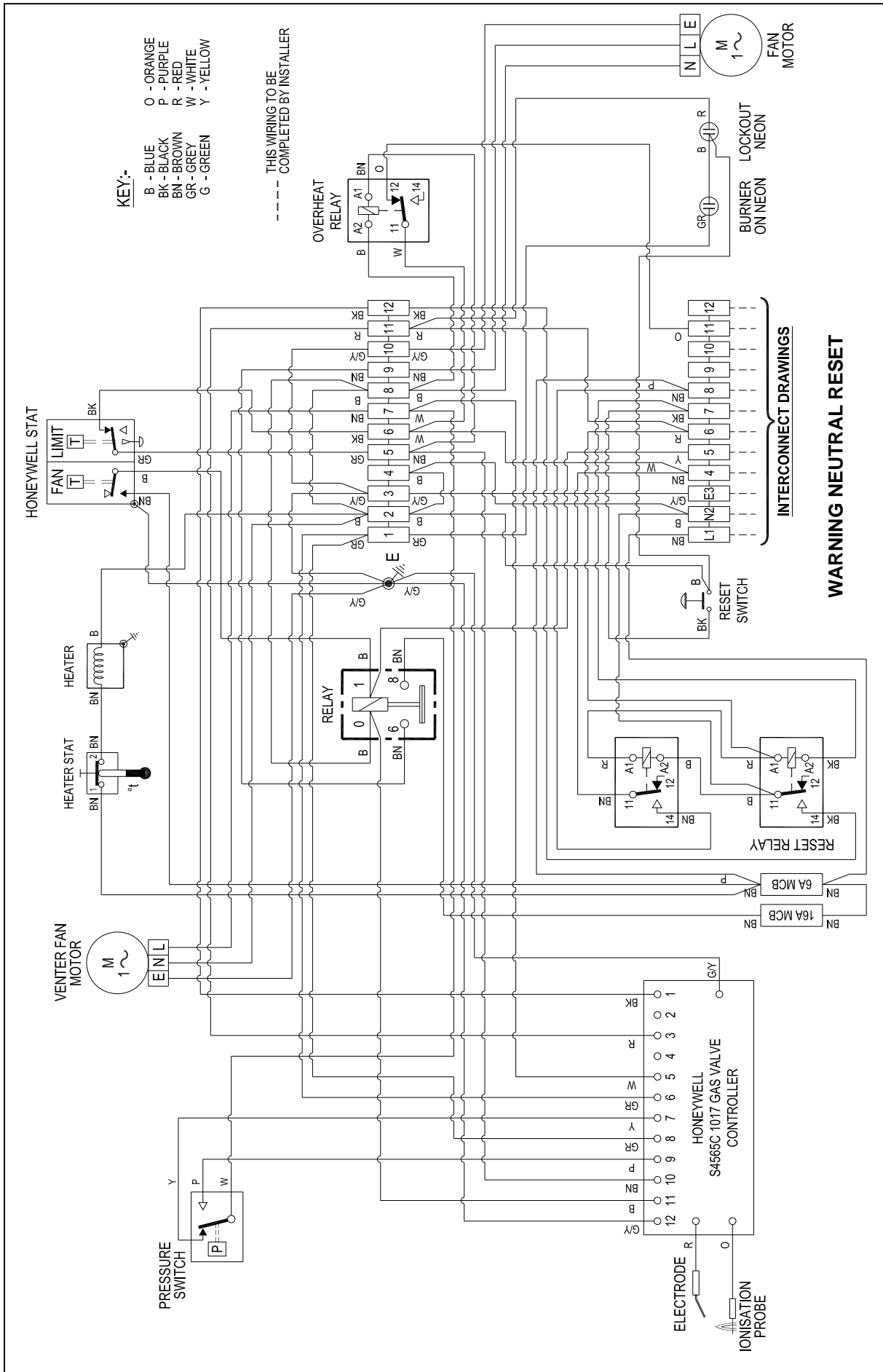

Wiring Diagram 33-67-685 EVRC 12-42 Auto ignition Hi/Low

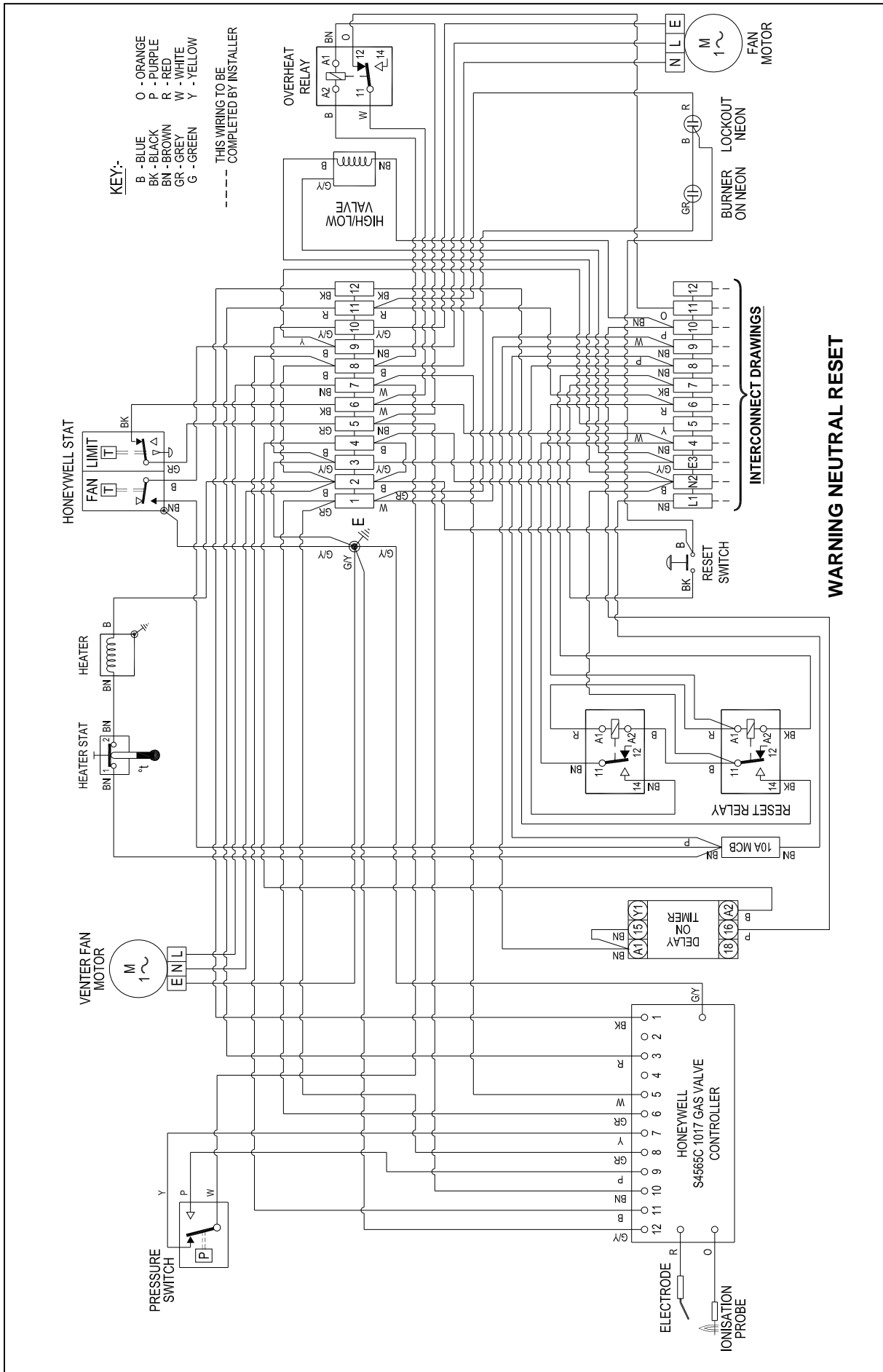

Wiring Diagram 33-67-686 VRC 50-60 Auto ignition Hi/Low

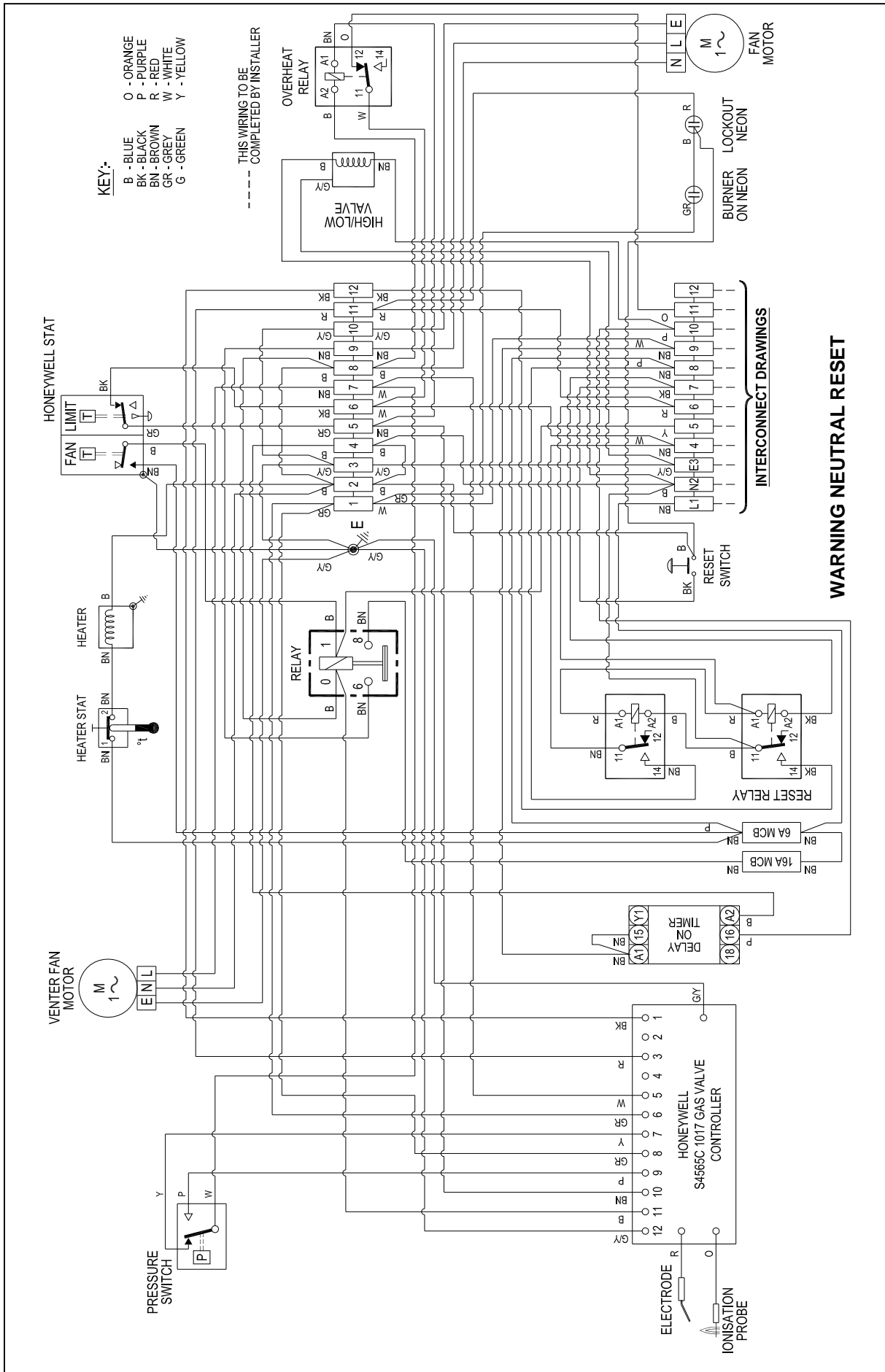

Wiring Diagram 33-67-687 EVRC 50-60 3 Phase Auto ignition Hi/Low

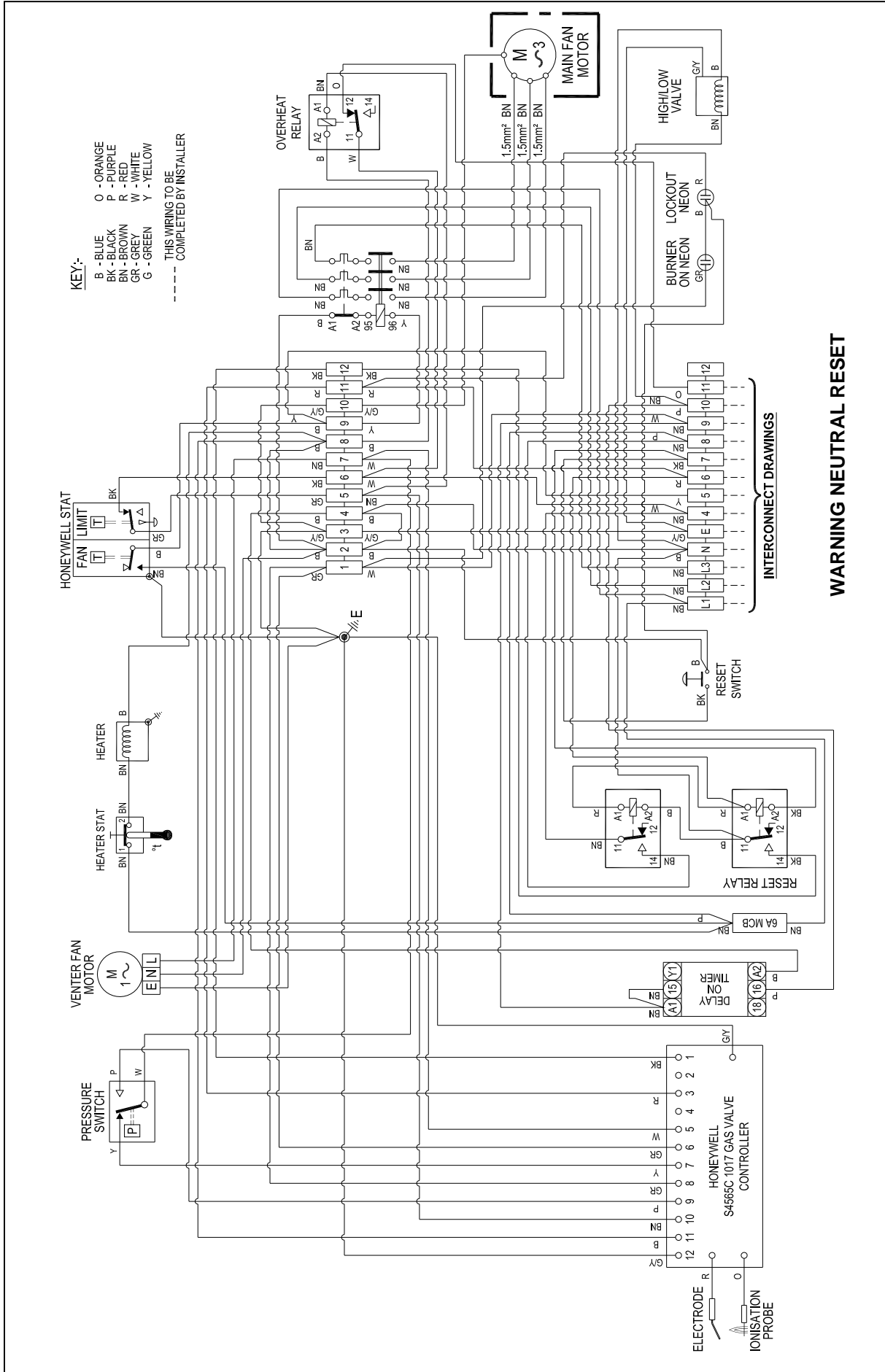

Wiring Diagram 33-67-688 EVRC 72-95 Auto ignition Hi/Low

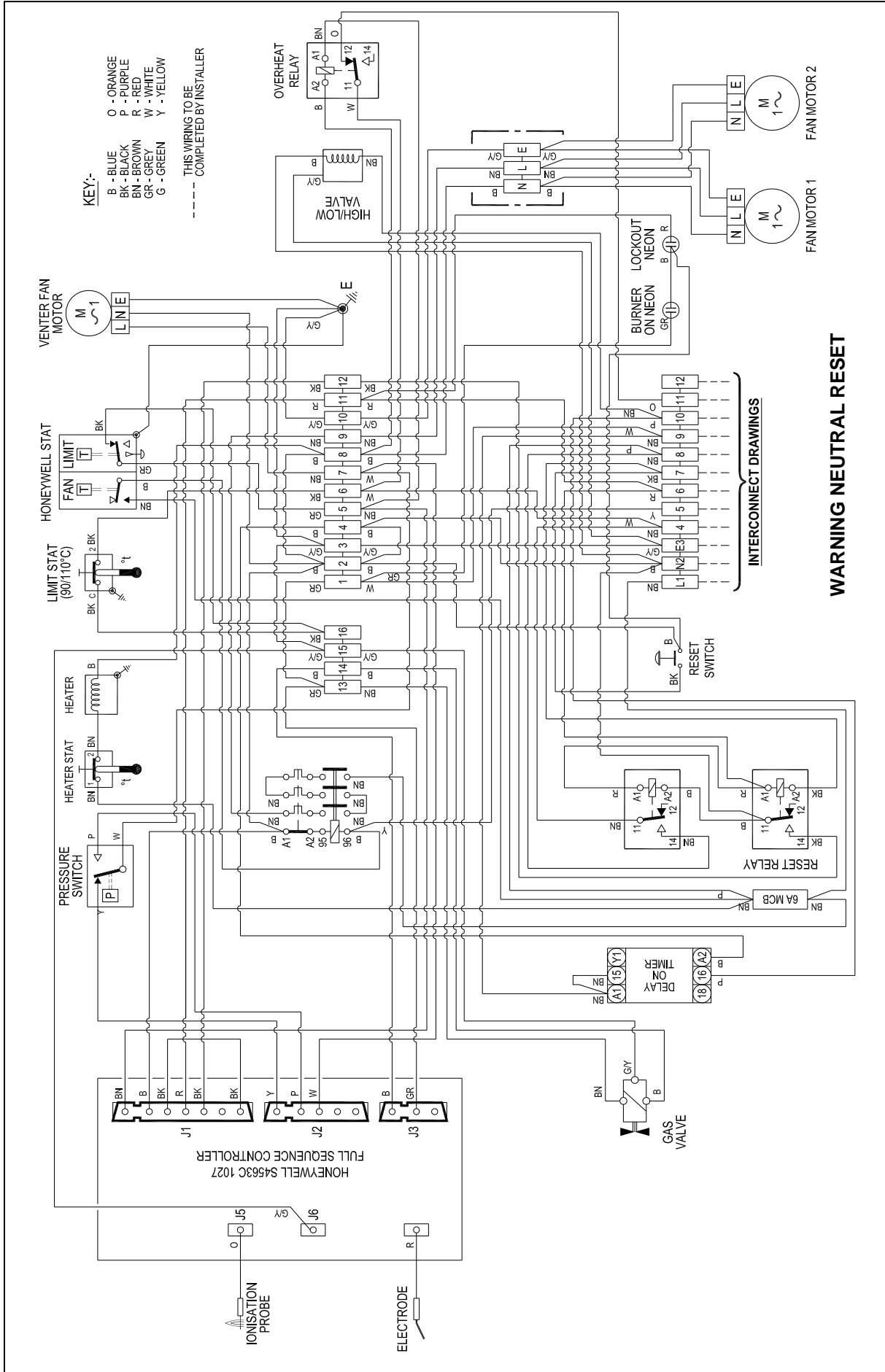

Wiring Diagram 33-67-689 EVRC 72-145 3 Phase Auto ignition Hi/Low

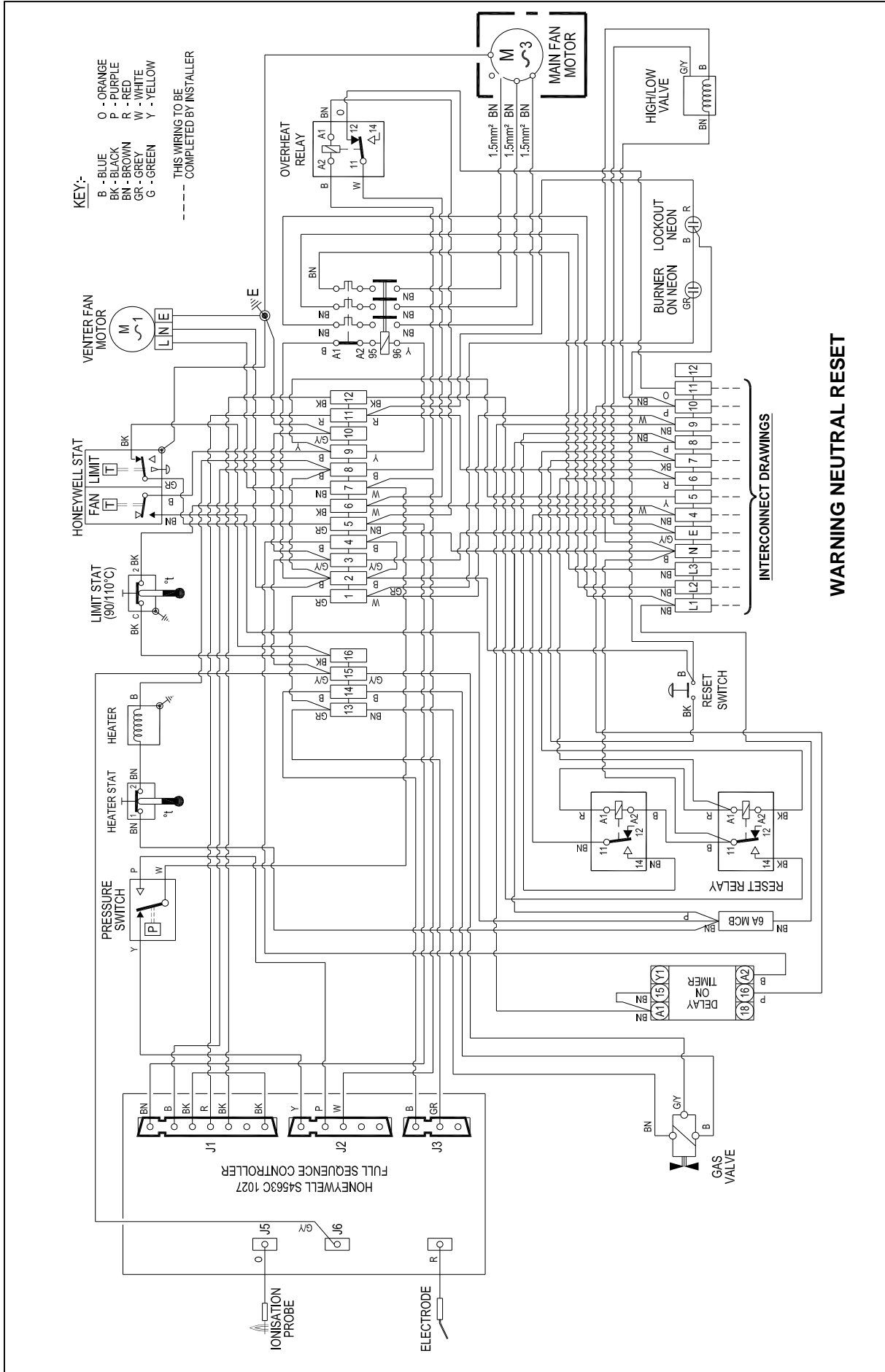

Wiring Diagram 33-67-690 EVRC 12-42 Auto Ignition Modulation

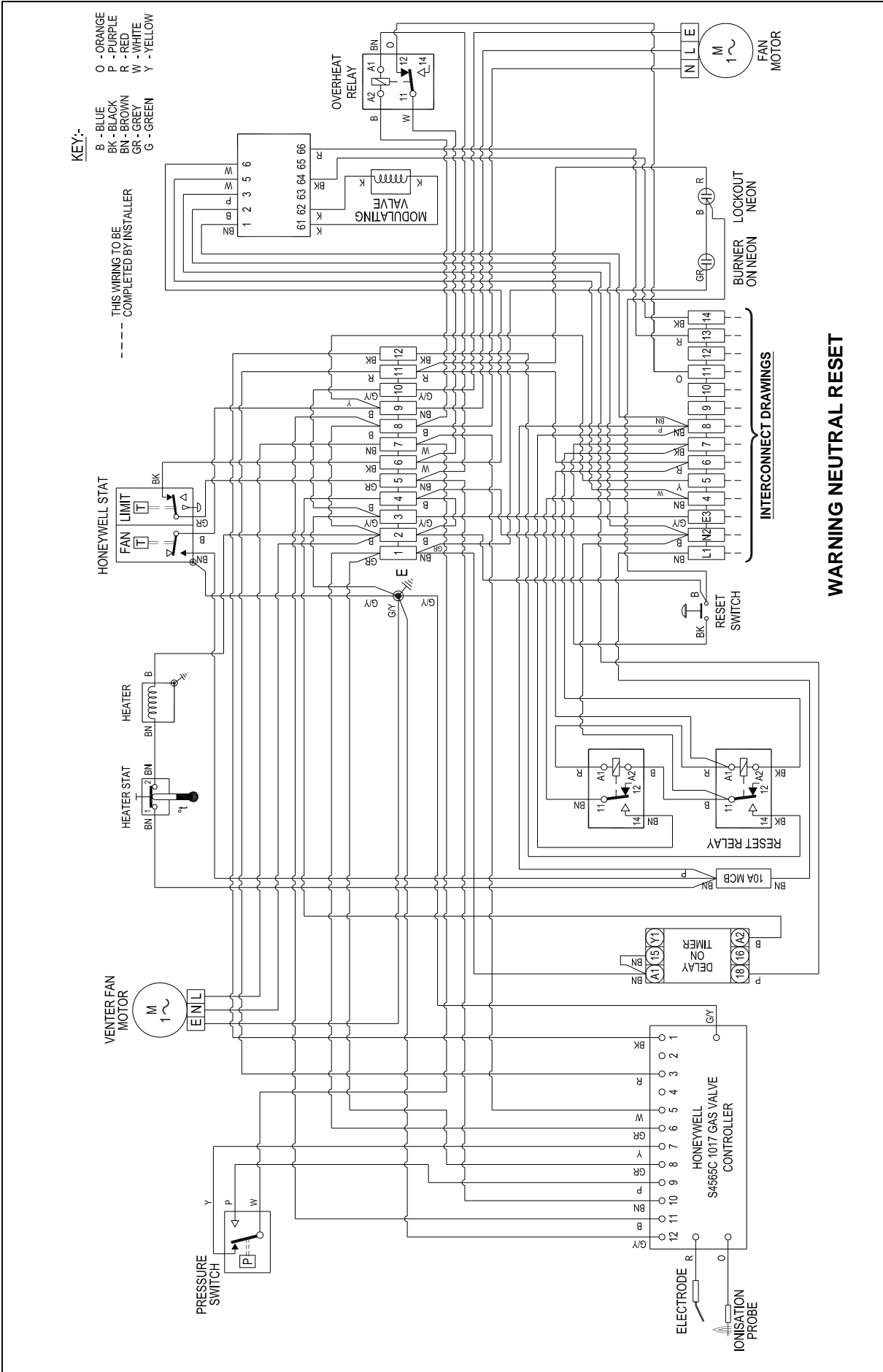

Wiring Diagram 33-67-691 EVRC 50-60 Auto Ignition Modulation

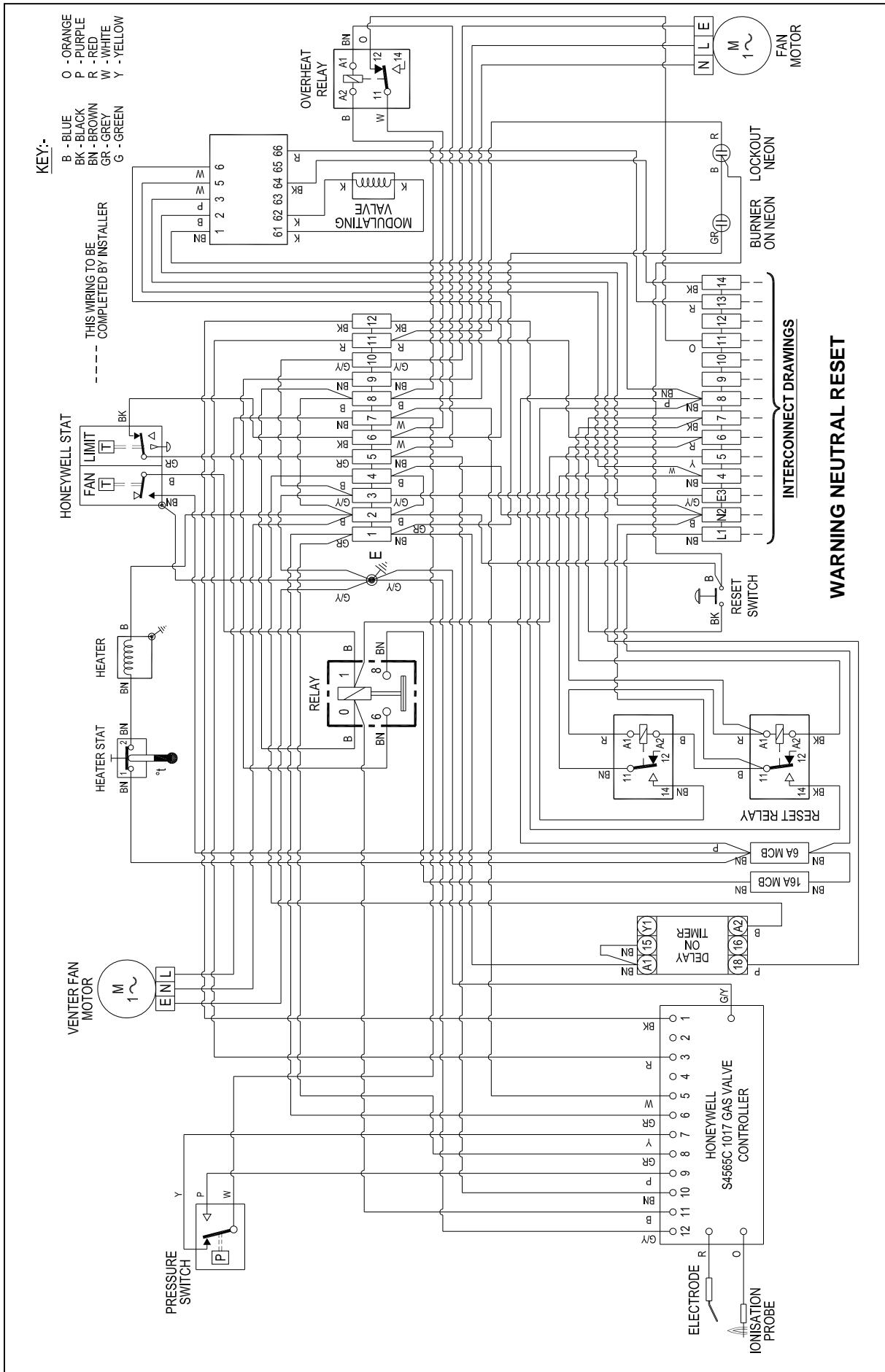

Wiring Diagram 33-67-692 EVRC 50-60 3 Phase Auto Ignition Modulation

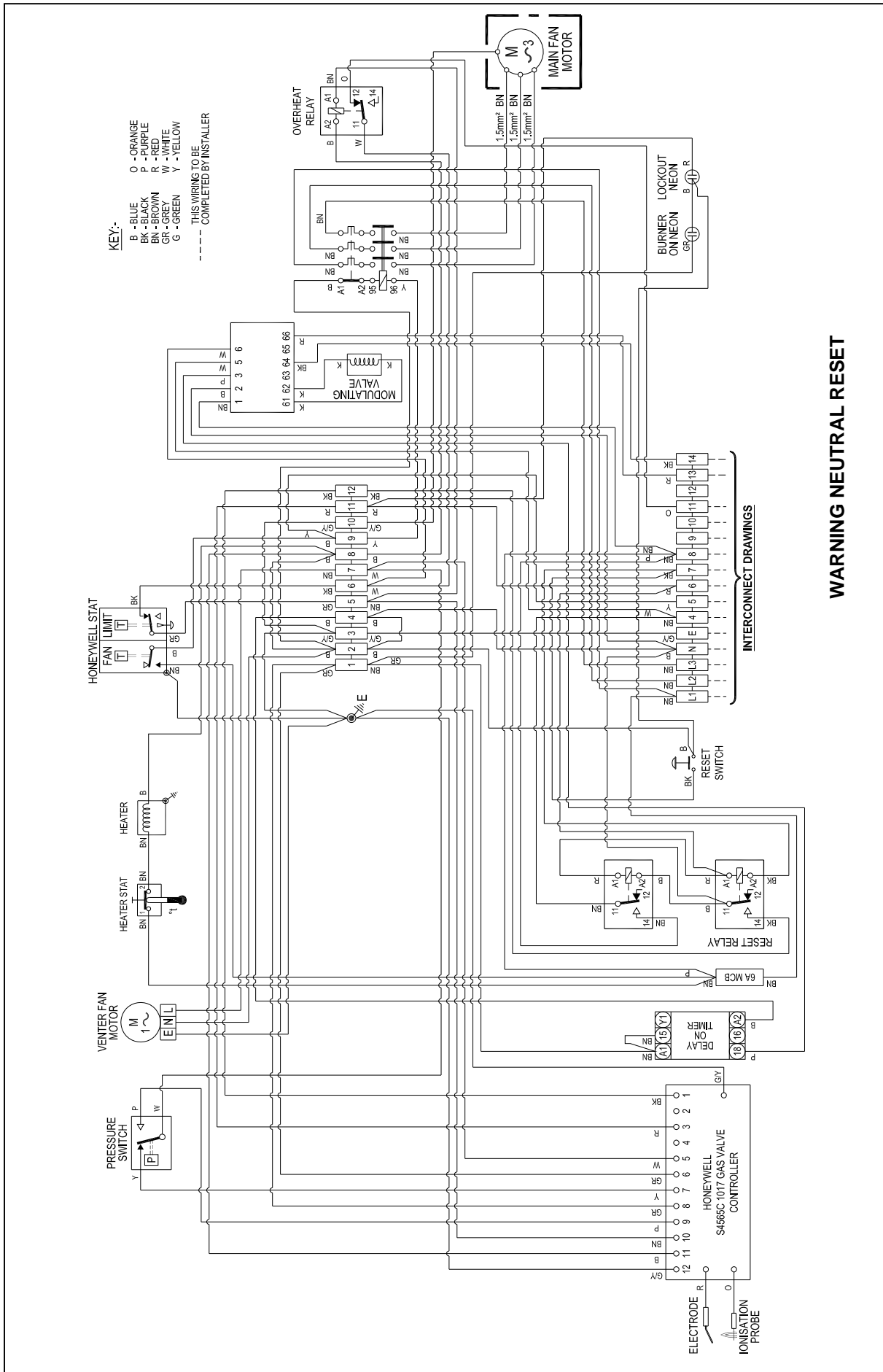

WARNING NEUTRAL RESET

Wiring Diagram 33-67-693 EVRC 72-95 Auto Ignition Modulation

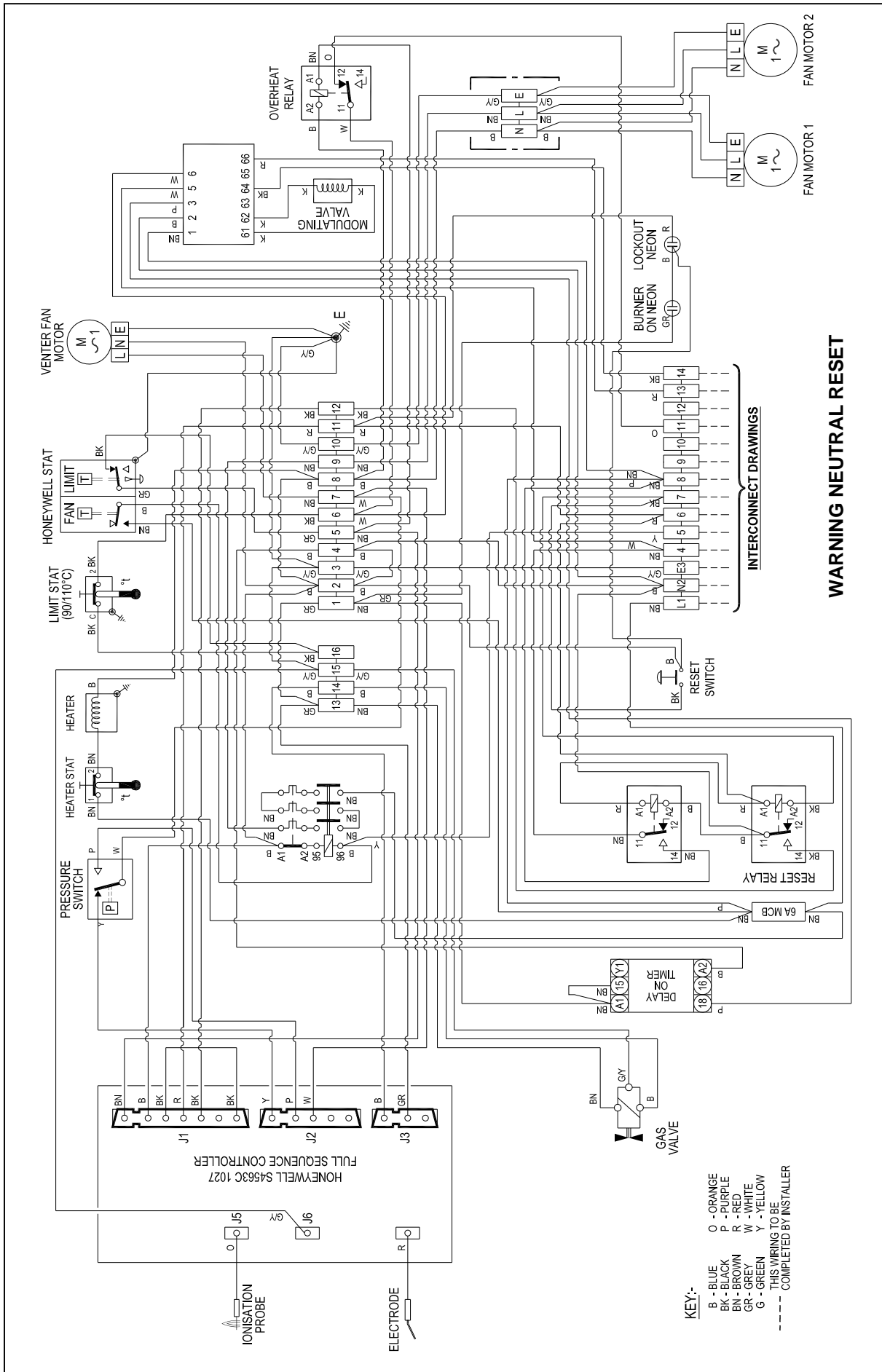

Wiring Diagram 33-67-694 EVRC 72-145 3 Phase Auto ignition Modulation

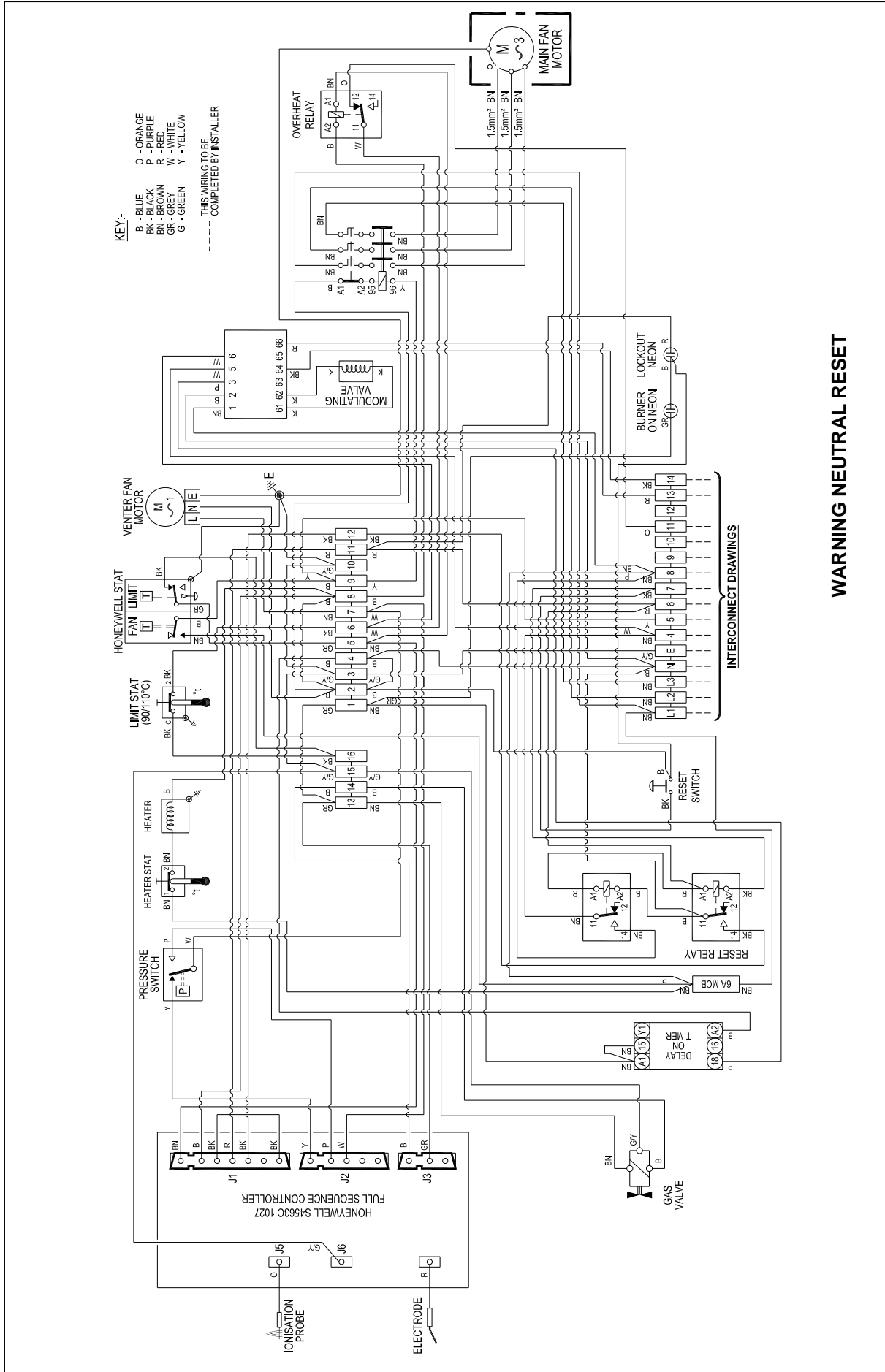

WARNING NEUTRAL RESET

Less Controls Connections On/Off (Hi/Low) 1 Phase 33-67-114

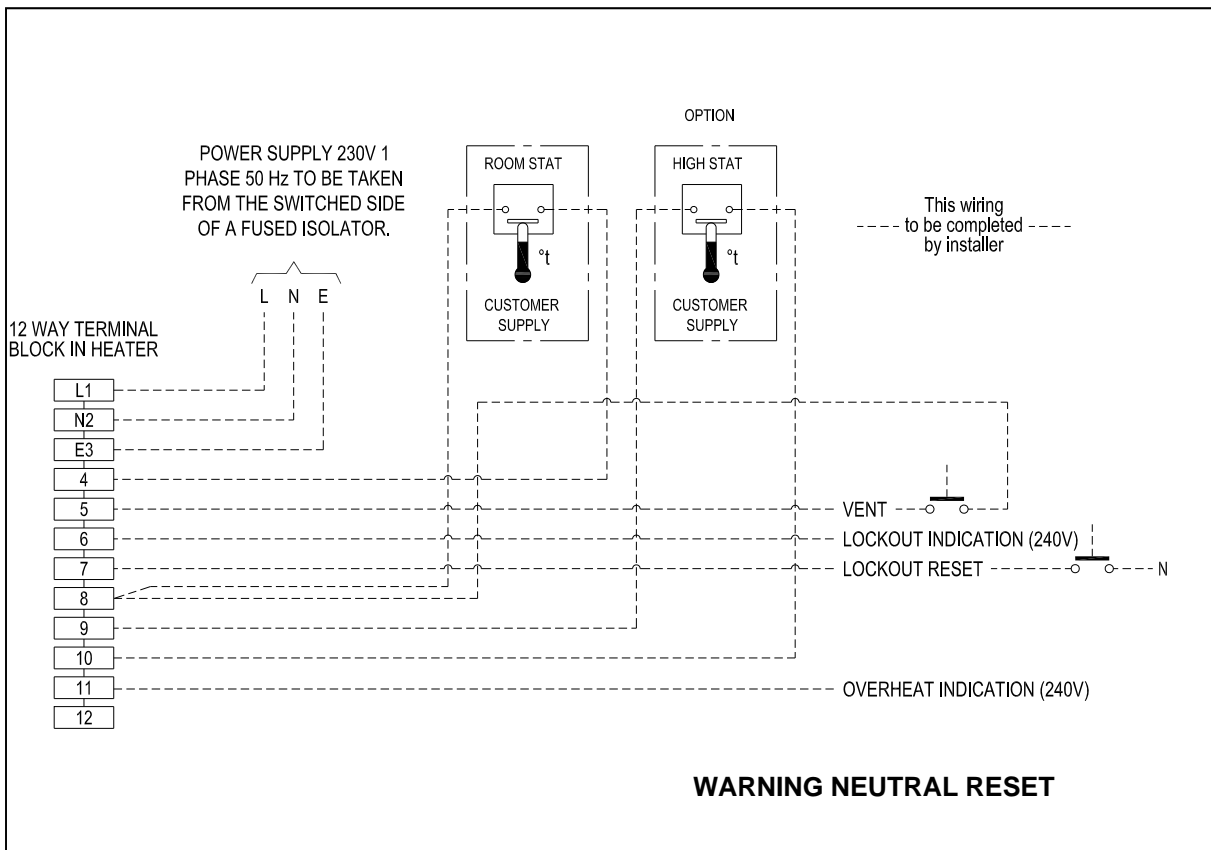

Less Controls Connections On/Off (Hi/Low) 3 Phase 33-67-115

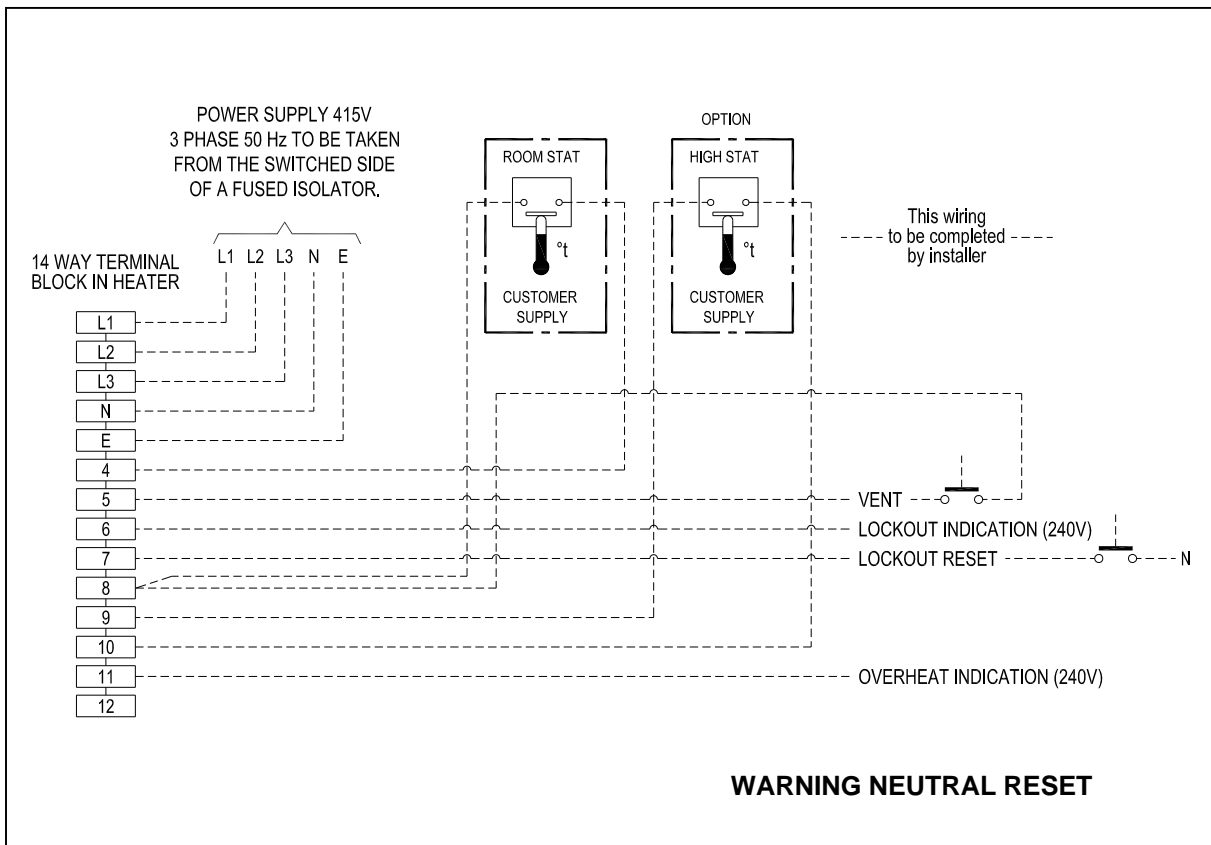

Less Controls Connections Modulation 1 Phase 33-67-221

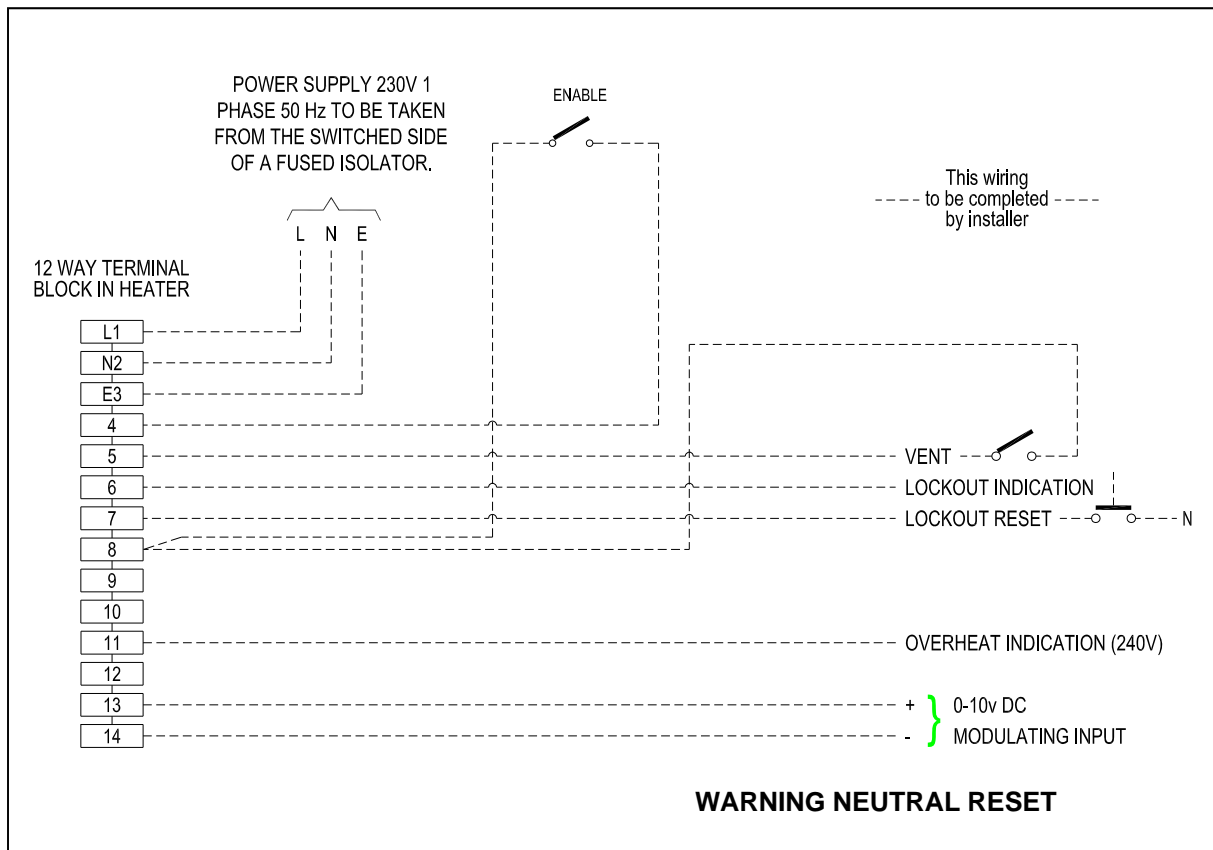

Less Controls Connections Modulation 3 Phase 33-67-222

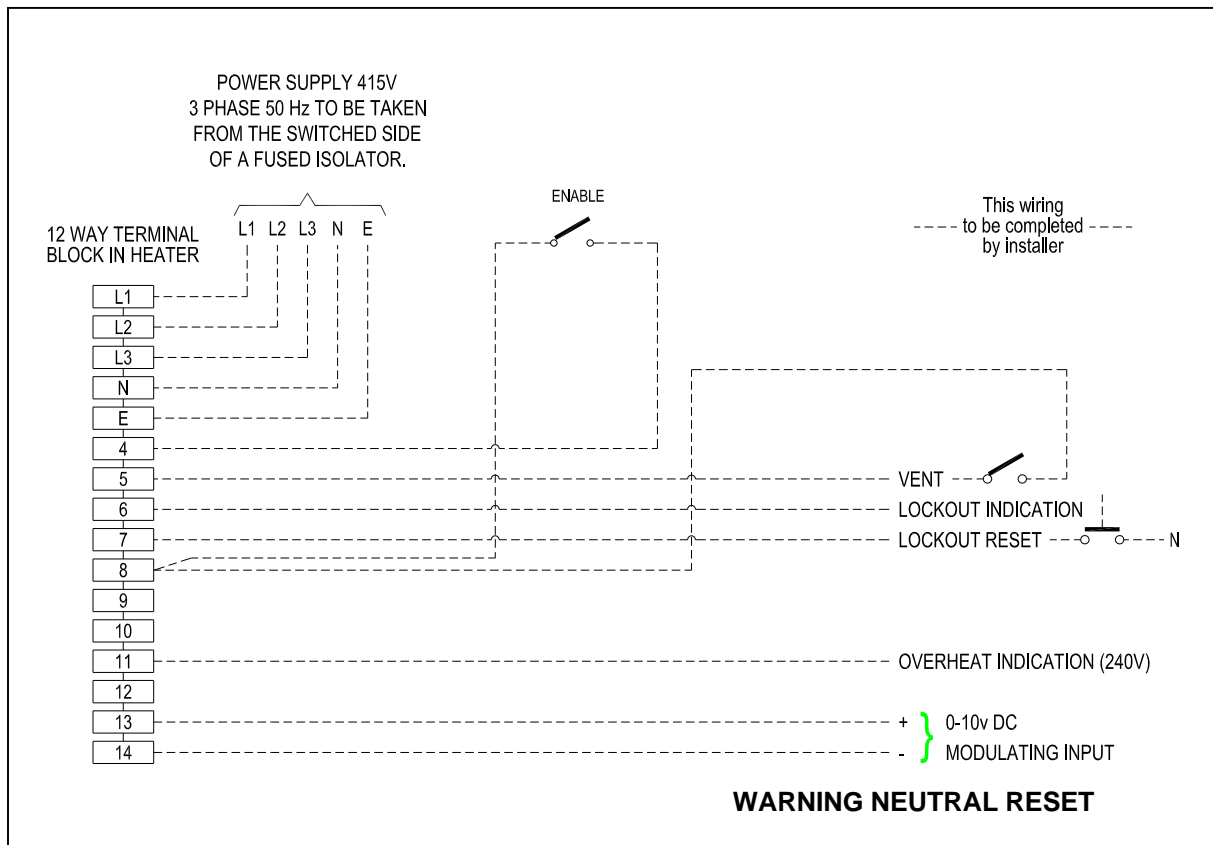



Benson Heating Ludlow Road Knighton
Powys LD7 1LP United Kingdom.

Telephone 01547 528534
Facsimile 01547 520399
Email sales@bensonheating.co.uk
Website www.bensonheating.co.uk



Benson Heating Ltd is a registered trademark of AmbiRad Limited. Because of continuous product innovation, Benson Heating reserve the right to change product specification without due notice.