

AMBIRAD VISION[®] VT RANGE

RADIANT TUBE HEATERS

INSTALLATION AND OPERATING MANUAL



INDEX

Section

Introduction and Document Index	
Installation Requirements -----	1
Assembly Instructions -----	2
Commissioning Instructions -----	3
Servicing Instructions-----	4
Spare Parts -----	5
Fault Finding Guide-----	6
Replacing Parts -----	7
User and Operating Instructions-----	8

WARNINGS

Nortek Global HVAC (UK) Ltd equipment must be installed and maintained in accordance with the relevant provisions of the Gas Safety (Installations and Use) Regulations 1998 for gas fired products. Due account should also be taken of any obligations arising from the Health and Safety at Works Act 1974 or relevant codes of practice. In addition the installation must be carried out in accordance with the current IEE wiring regulations (BS 7671), BS 6896 (Industrial & Commercial) and any other relevant British Standards and Codes of Practice by a qualified installer. All external wiring MUST comply with the current IEE wiring regulations.

Part No. 700025



Introduction.

Welcome to the new range of high efficiency AmbiRad Vision Hi/Low radiant tube heaters.

Local regulations may vary in the country of use and it is the installers responsibility to ensure that such regulations are satisfied.

All installation, assembly, commissioning and service procedures must be carried out by suitable qualified competent persons to the statutory regulations in the country of use.

When assembling, installing, commissioning and servicing is undertaken on radiant tube heaters specified in these instructions, due care

and attention is required to ensure that working at height regulations are adhered to at the mounting heights specified.

 **PLEASE READ** this document prior to installation to familiarise yourself with the components and tools you require at the various stages of assembly.

All Dimensions shown are in mm unless otherwise stated.

The manufacturer reserves the right to alter specifications without prior notice.

Document Index.

1 Installation Requirements

- 1.1 Health & Safety
- 1.2 Model Definitions
- 1.3 Heater Suspension
- 1.4 Wall Mounting
- 1.5 Clearance to Combustibles
- 1.6 Gas Connection & Supply Details
- 1.7 Electrical Connections
- 1.8 Ventilation Requirements
 - 1.8.1 Unflued Radiant Heater
 - Mechanical Ventilation
 - Natural Ventilation
 - 1.8.2 Flued Radiant Heater
 - Mechanical Ventilation
 - Natural Ventilation
- 1.9 Flue & Combustion Air Inlet Options
- 1.10 Technical Details

2 Assembly Instructions

- 2.1 Tools Required
- 2.2 Assembly Notes
 - 2.2.1 Tubes
 - 2.2.2 Turbulators
 - 2.2.3 Brackets
 - 2.2.4 Couplers
 - 2.2.5 U Bends
 - 2.2.6 Reflectors
 - 2.2.7 End Caps
 - 2.2.8 Burner Assembly
 - 2.2.9 Flue Outlet
 - 2.2.10 Detailed Assembly Drawings

3 Commissioning Instructions

- 3.1 Tools Required
- 3.2 Commissioning Chart for VT Heaters

4 Servicing Instructions

- 4.1 Tools Required
- 4.2 Burner Description
- 4.3 Burner Removal
- 4.4 Burner Gas Injector Servicing
- 4.5 Combustion Fan Servicing
- 4.6 Burner Head and Electrode Servicing
- 4.7 Radiant Tube Servicing
- 4.8 Reflector Servicing
- 4.9 Inspection of Flue
- 4.10 Re-commissioning after Service

5 Spare Parts

6 Fault Finding Guide

7 Replacing Parts

- 7.1 Burner Controller Replacement
- 7.2 Air Pressure Switch Replacement
- 7.3 Gas Valve Replacement

8 User and Operating Instructions

- 8.1 To Start Heater
- 8.2 To Switch Off Heater
- 8.3 Routine Maintenance Between Service Intervals
- 8.4 Frequency of Servicing

1. Installation Requirements.

 Isolate any electrical supply to the heater and controller before proceeding.

1.1 Health and Safety

AmbiRad heaters must be installed in accordance with the relevant provisions of the Gas Safety (Installations and Use) Regulations 1998. Due account should also be taken of any obligations arising from the Health and Safety at Works Act 1974 or relevant codes of practice. In addition the installation must be carried out in accordance with the current IEE wiring regulations (BS 7671), BS 6896:2005 (Industrial & Commercial) and any other relevant British Standards and Codes of Practice by a qualified installer. Isolate all electrical supplies to the heater & controller before proceeding.

For your own safety we recommend the use of safety boots and leather faced gloves when handling sharp or heavy items. The use of protective eye wear is also recommended.

1.2 Model Definitions

VTUT = AmbiRad Vision U Tube heater with painted forced two stage burner, stainless steel reflector & end caps.

VTLF = AmbiRad Vision Single Linear heater with painted forced two stage burner, stainless steel reflector & end caps.

VTAUT & VTALF = As above except: aluminised reflector and end caps.

VT CUT & VTCLF = As above except: Stainless steel IP rated housing, stainless steel brackets, reflector and end caps

1.3 Heater Suspension

 See fig 1b. Attachment to the heater support lugs should be made by a 'speed link', D shackle or in the case of drop rods, a closed formed hook. The hanging attachments to overhead steelwork etc. must be purpose made to good sound engineering practice or of a proprietary type fixing. They must be adequately fixed and designed to carry the whole weight of the heater. In the event of suitable roof steelwork being unavailable, additional steelwork should be fitted to enable vertical hangers to be used for suspending the heaters.

These methods are illustrated in Figure 1.b. If there are any doubts as to the strength or suitability of roof steelwork to which heaters are

to be suspended, please refer to a Consultant, Architect or owner of the building. The recommended mounting heights for AmbiRad heaters are given in the table below.

Model	Recommended Mounting Height (m)	
	Horizontal	Inclined / wall mounted
25	5.0 - 8.0m	4.0 - 5.0m

1.4 Wall Mounting

These radiant tube heaters can be wall mounted using the appropriate bracket (AmbiRad part no WMB-13-22-38).

When using the wall mounting brackets the heater must be inclined at an angle between 30° and 45°.

Table 1 Angle Mounting

Heater Size	Required angle	U Tube		Linear	
		Chain length	Eyebolt position	Chain length	Eyebolt position
25	30-35°	10 links	2	7 links	1
	45°	13 links	2	9 links	1

Figure 1.a. Angle Mounting using the Wall mounting bracket

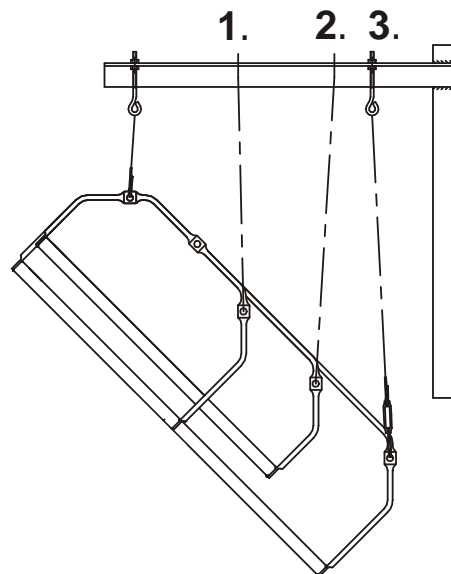
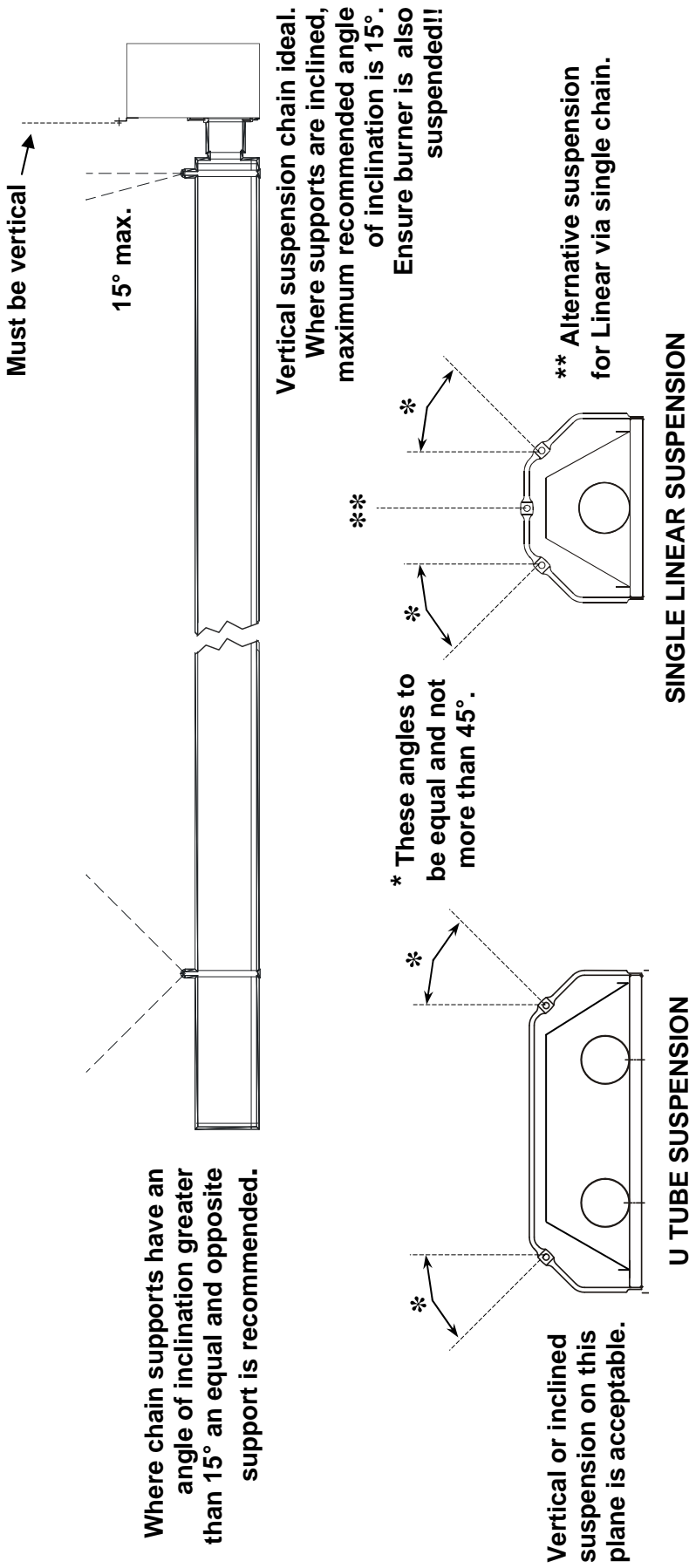
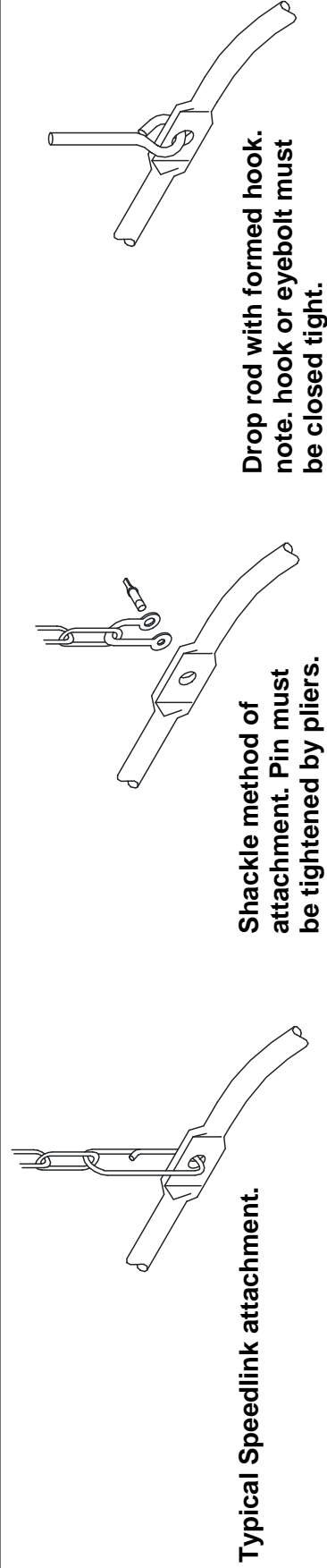

Figure 1.b. Recommended Methods of Heater Suspension.



ON U TUBE VARIANTS THE HEATER SHOULD SLOPE DOWNWARDS TOWARDS THE RETURN BEND AND ON LINEAR VARIANTS SHOULD SLOPE DOWNWARDS TOWARDS BURNER BY APPROX. 10mm FOR BOTH HORIZONTAL AND WALL MOUNTED INSTALLATIONS.



1.5 Clearance to Combustibles.

 The minimum clearances to combustible materials are given in the tables below. These minimum distances **MUST** be adhered to at all times.

Figure 2.a Diagram illustrating the clearance to combustibles



VTUT / VTAUT / VTCUT		25
Above Reflector	A	180
Above Burner / Heater Outlet	B	500
To the Sides	C	1000
Below Tubes	D	1700
Horizontally from Heater Outlet (UNFLUED)	E	1200
End Wall	F	500

Figure 2.b Diagram illustrating the clearance to combustibles

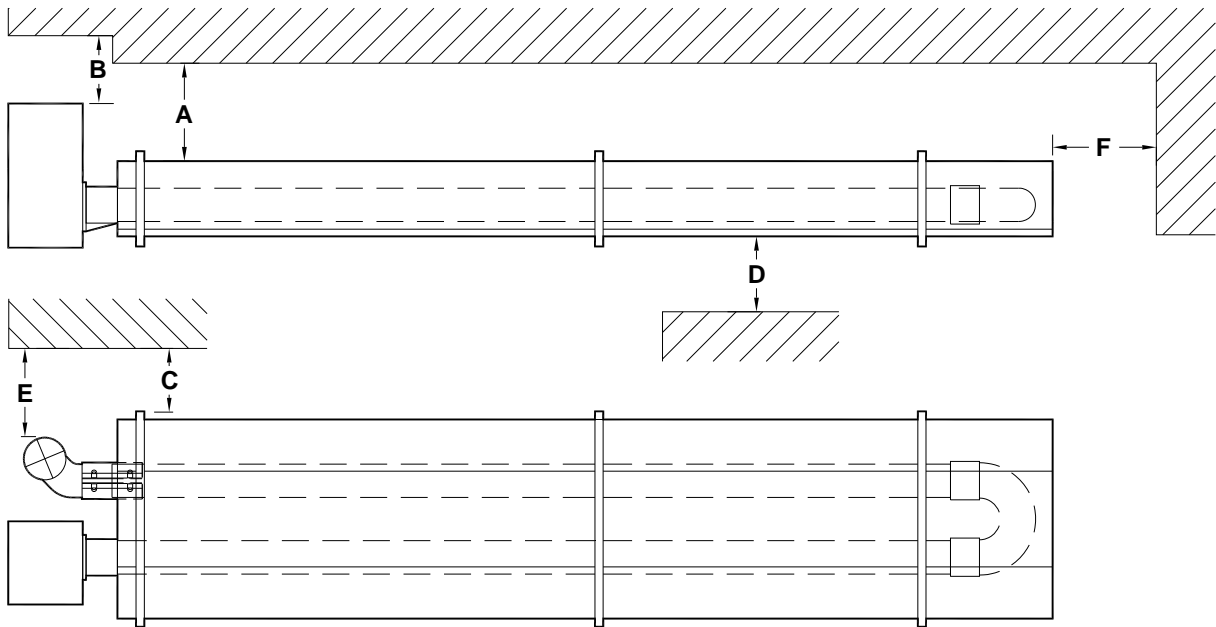
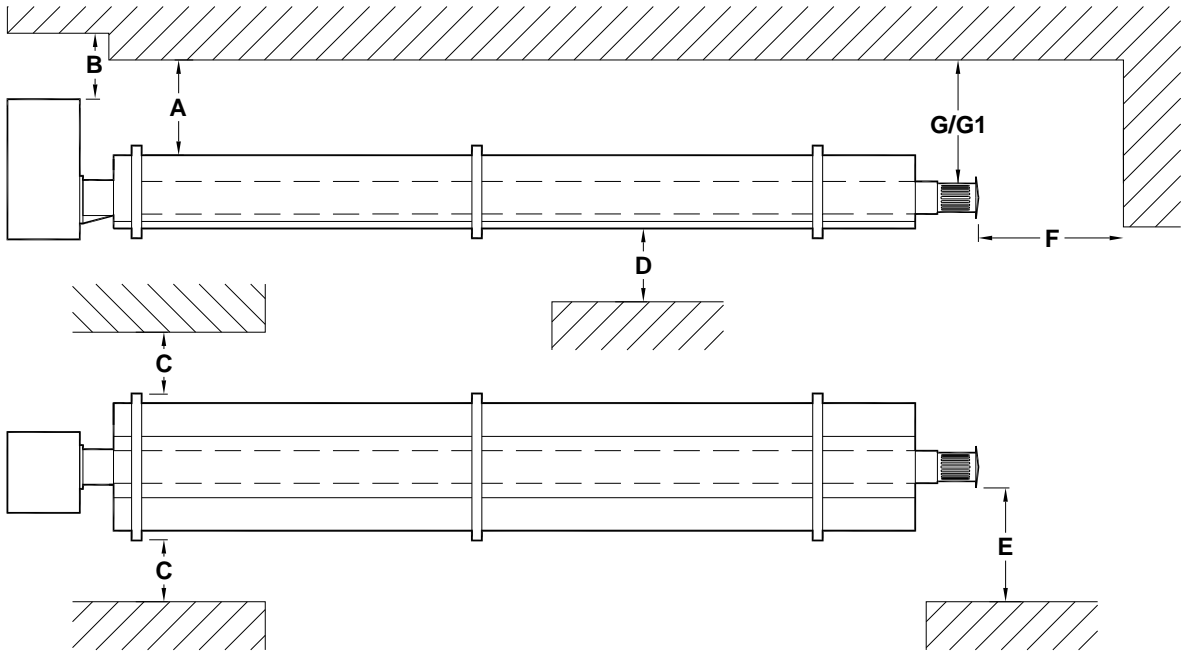

VTLF / VTALF / VTCLF		25
Above Reflector	A	150
Above Burner	B	500
To the Sides	C	750
Below Tubes	D	1700
Horizontally from Heater Outlet (UNFLUED)	E	1200
End Wall	F	500
Above Heater Outlet (FLUED)	G	150
Above Heater Outlet (UNFLUED)	G1	500

1.6 Gas Connection and Supply

! Before installation, check that the local distribution conditions, nature of gas and pressure, and adjustment of the appliance are compatible.

A competent or qualified engineer is required to either install a new gas meter to the service pipe or to check that the existing meter is adequate to deal with the rate of gas supply required. Installation pipes should be fitted in accordance with BS 6896:2005, so that the supply pressure, as stated in Table 4 will be achieved. It is the responsibility of the competent engineer to ensure that other relevant Standards and Codes of Practice are complied with in the country of installation. Pipes of smaller size than the heater inlet gas connection must not be used. The complete installation must be tested for soundness as described in the country of installation.

! The gas union service cock MUST be fitted in the gas supply close to the heater, but not onto the burner itself.

i Take care when making a gas connection

to the heater not to apply excessive turning force to the internal controls.

A flexible hose is installed to allow safe linear expansion of the heater without creating undue stress on the gas supply pipe work. It is therefore important that a tested and certified hose assembly made to ISO 10380 2003, supplied with 1/2" BSP female cone seat adapters, is installed as per these instructions.

It is also important to ensure that expansion is taken up in the body of the flexible hose, and not on its attachment to the pipe work. The cone seat adapter supplied on one end of the flexible gas hose provides a 'swivel' action, and must be fitted on the burner using a 1/2" BSP barrel nipple to provide ease of disconnection for future servicing. This assumes that the heater and fixed gas supply to the isolating valve have been installed.

i The installation layout described below is the only method recommended by the institute of gas engineers, the hose manufacturer, and AmbiRad and must only be carried out by a qualified/competent gas engineer.

Figure 3. Correct Installation of Flexible Gas Connection

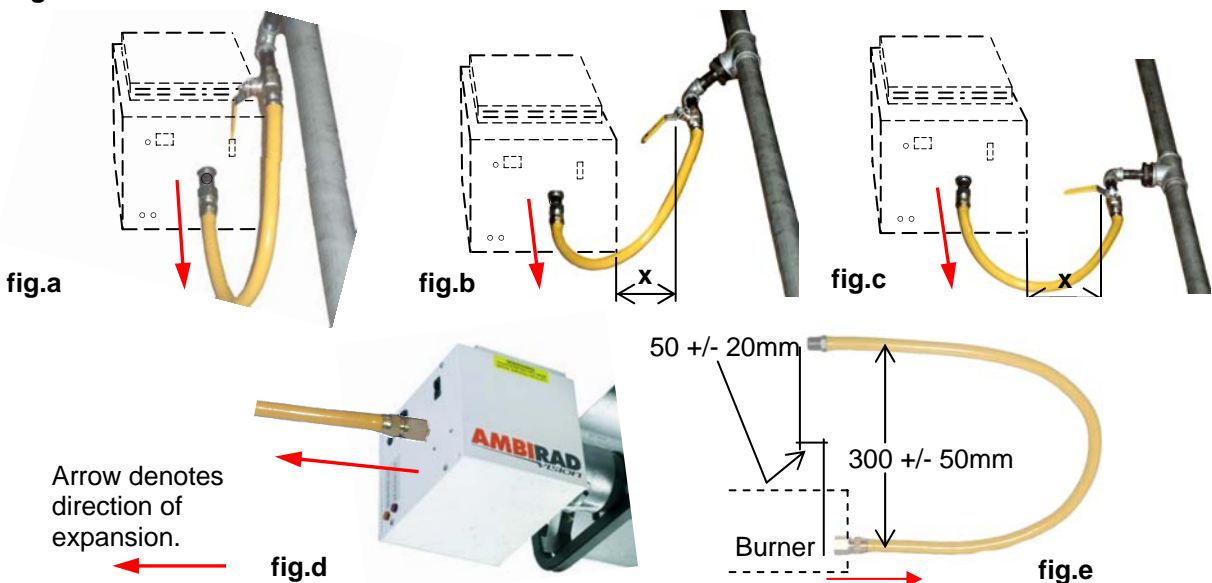

Depending on the specific installation, the flexible gas hose may be routed to the gas cock at any of the following angles in relation to the burner:

Vertical (fig.a)

45° angle (fig.b)

90° angle (fig.c)

Any other position in between these angles is acceptable.

! A clearance distance 'x' of min 200mm must be observed to allow side door access .

Care must be taken to observe the minimum pipe bend diameter (minimum 250mm, maximum 350mm) & pipe expansion distance (minimum 30mm, maximum 70mm) as shown in fig.e.

i Maximum bend diameter for the 1000mm hose is 450mm.

i The correct installation as shown will allow for approx 100mm of movement due to expansion.

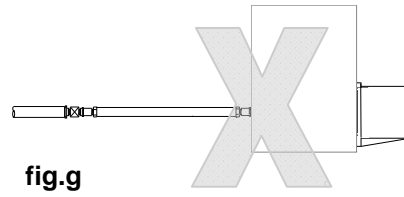
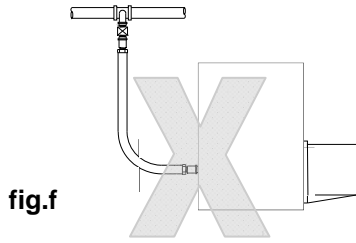

The methods shown in fig.f and fig.g are unacceptable, due to undue stress on the hose & fittings.

Table 2 Gas Supply Pressures

Gas Category	I2H	I3P
Gas Type	Natural Gas (G20)	Propane (G31)
Max Supply Pressure (mbar)	25	45
Min Supply Pressure (mbar)	17	25
Nominal Pressure (mbar)	20	37

Gas Supply

Connection R $\frac{1}{2}$ ½in BSP External Thread

1.7 Electrical Connections

This appliance must be earthed.
Supply 230V 50Hz single phase.
Standard heater 241W.
Current rating 1.05 amp max (inductive).
Fuse: external 3 amp.

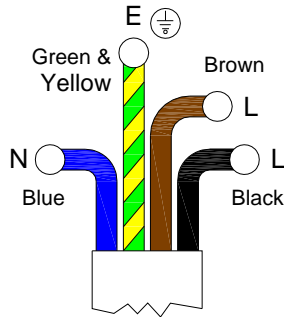

The flexible supply cables should be of 0.5mm² and comply with BS 6500:2000. The wires in the mains lead are coloured in accordance with the following code: Green & Yellow Earth; Blue Neutral; Brown Live; Black Live

All electrical work should be carried out to IEE standards by a competent electrician. The electrical connection to the heater is made by means of a four pin plug-in power connector. Live, neutral earth & high fire connections should be made via a flexible supply cable to the power connector and routed clear of the heater or tubes.

It is recommended the heater or group of heaters are controlled by thermostats, a time switch and if required manual control switches and a frost thermostat.

 We recommend use of AmbiRad approved controls. Please refer to control manual for siting and installation details. Where alternative manufactures controls are used, please refer to their instructions for their siting and installation details.

Figure 4.a Typical VTUT/VTAUT/VTCLF Wiring Connections

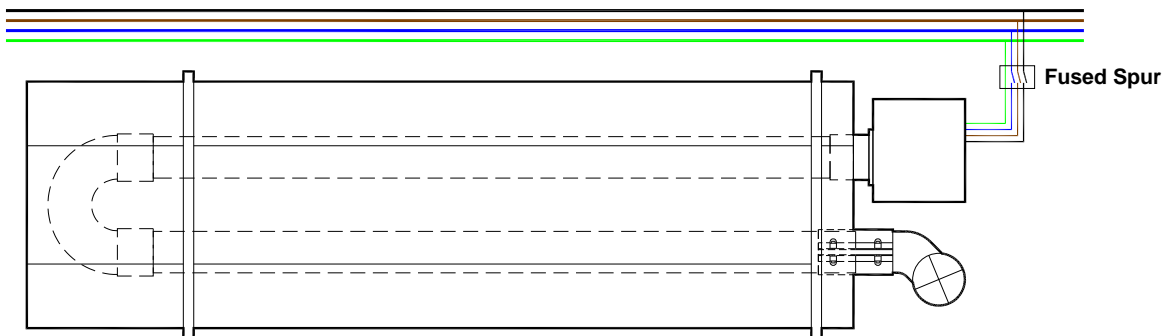

Figure 4.b Typical VTLF/VTALF/VTCLF Wiring Connections

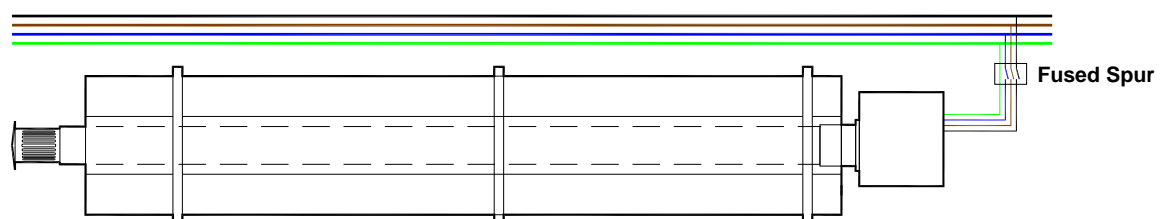
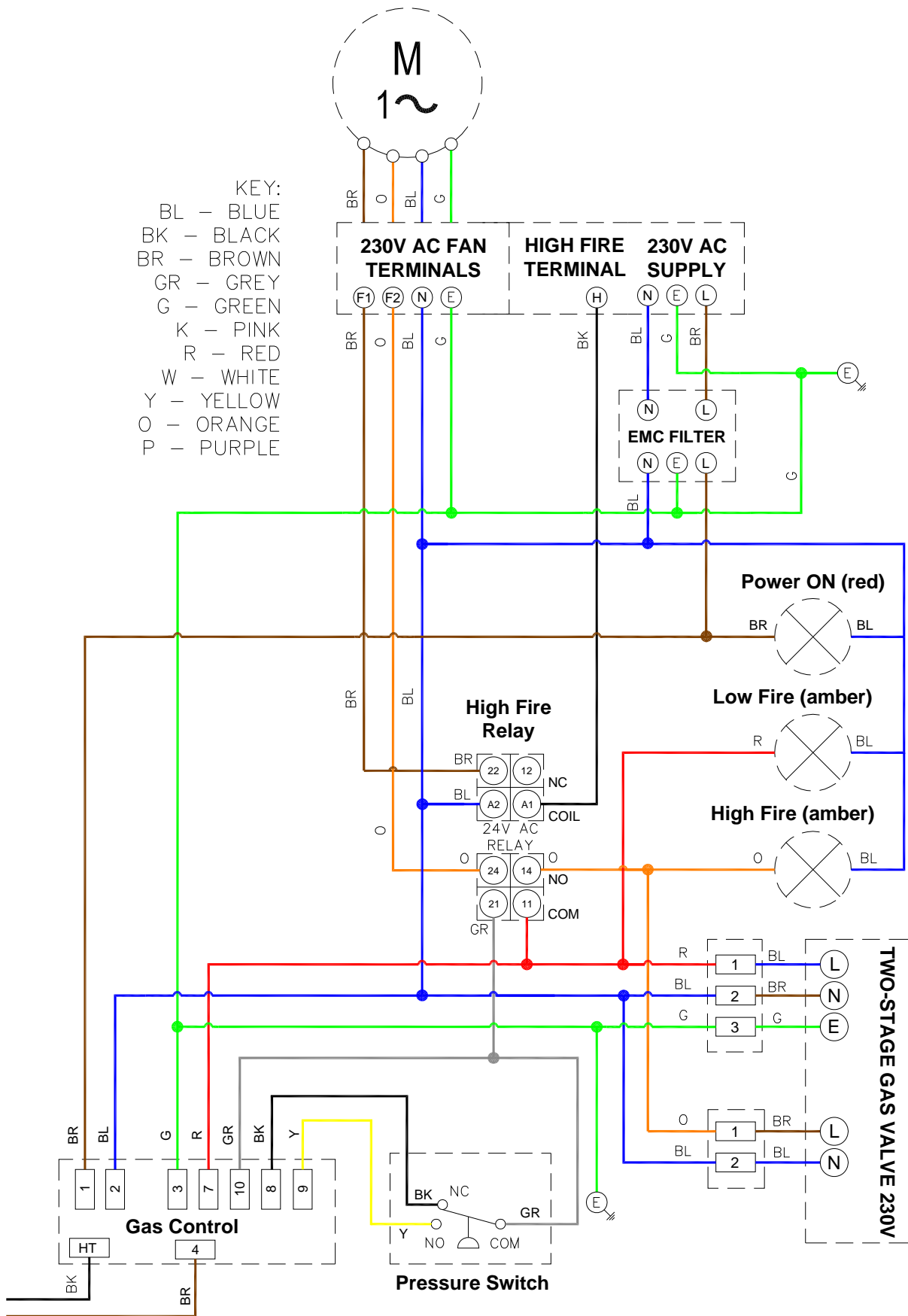

Figure 5. Internal Burner Wiring Diagram.



1.7 Electrical Connections cont`d

AmbiRad Smartcom MZ controller shown.

VT models:

These models are supplied with a loose four way connector ready to be connected to the controller as shown in the diagram below

Note:

If an AmbiRad controller is NOT used, then any third party controller must be capable of disconnecting all outputs to the burner in the event of a fault.

Figure 5a. VT Models.

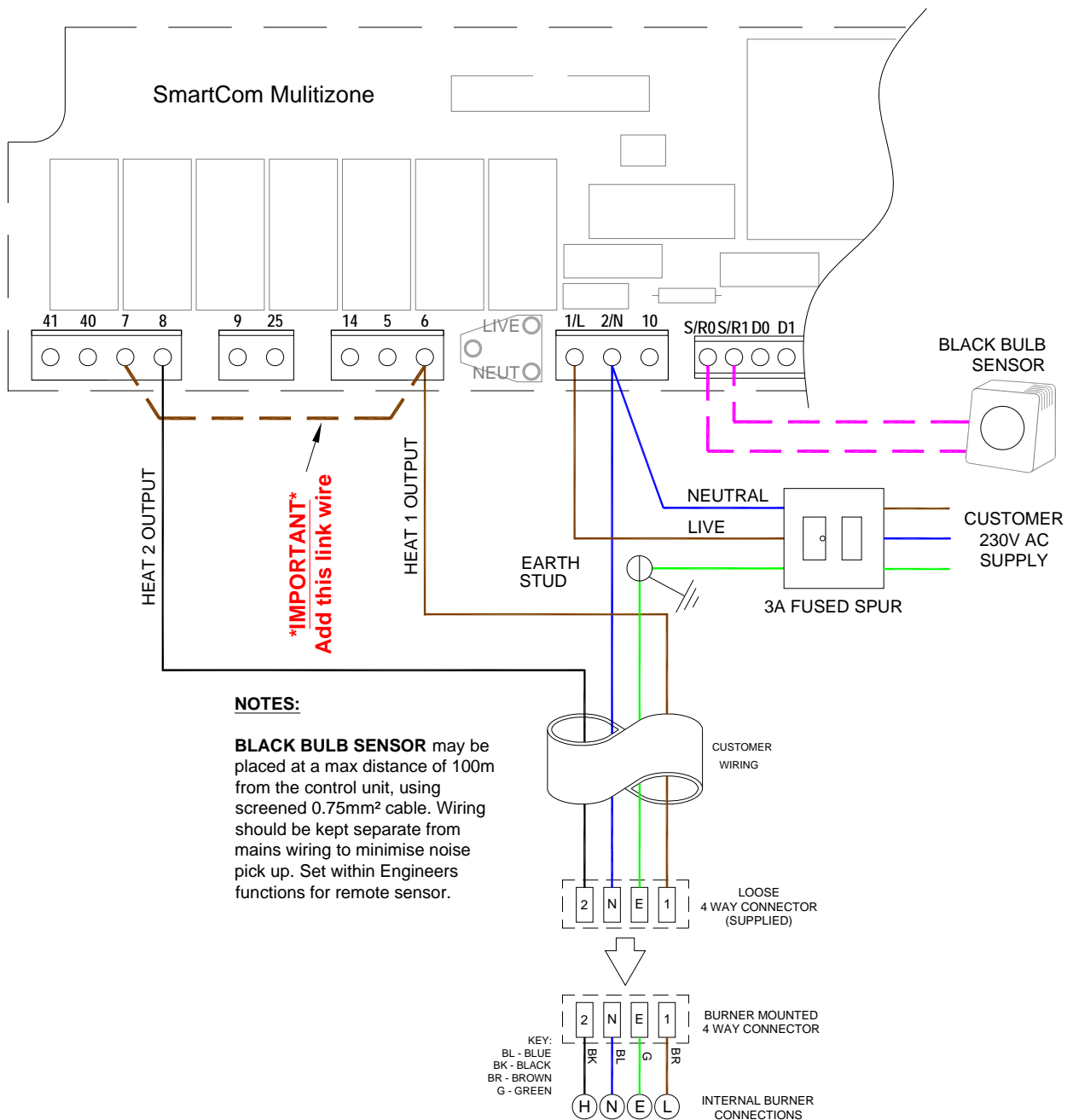
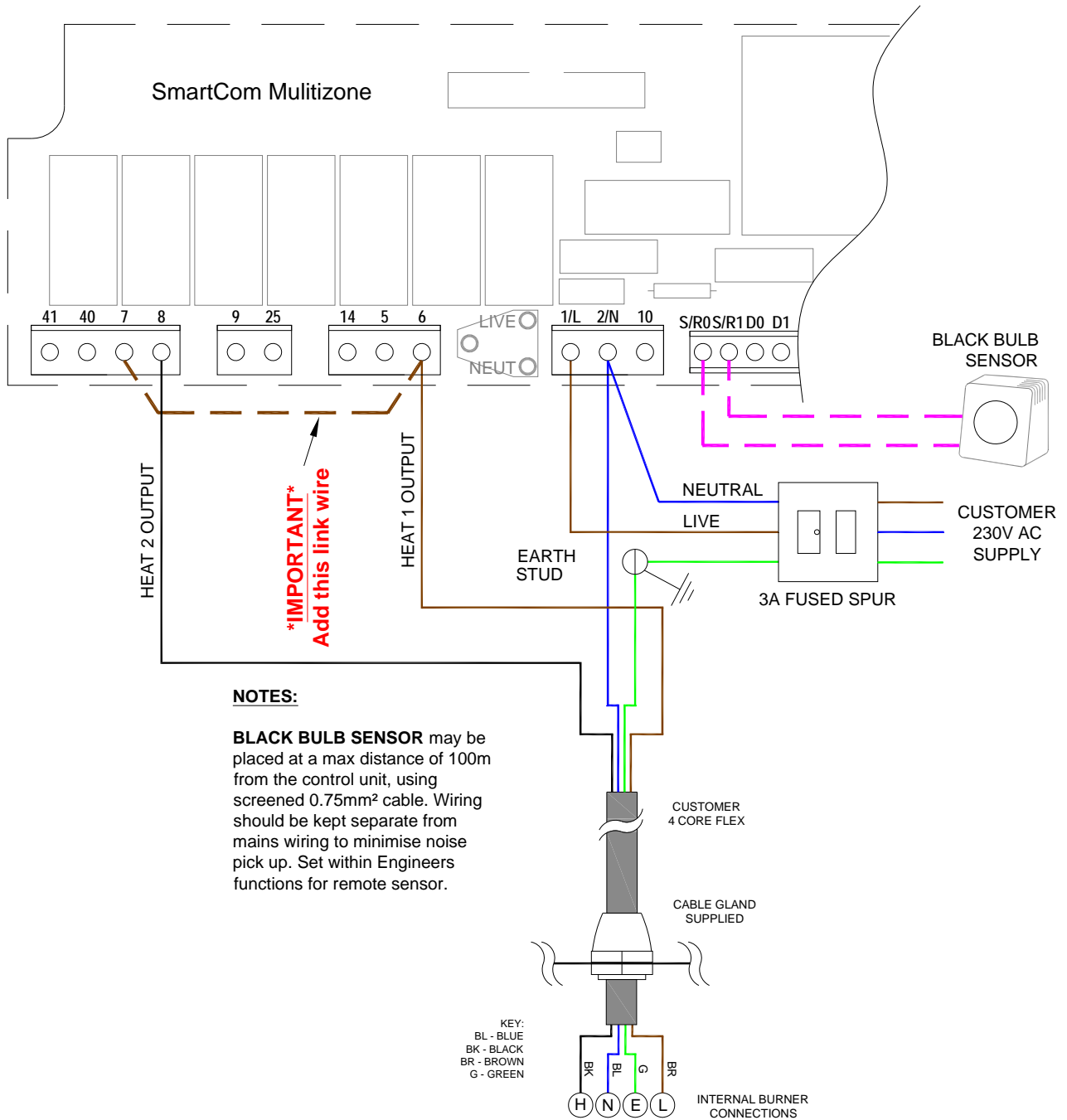

Figure 5b. VTC Models.

VTC models (carwash):

These models require a four core flying lead to be connected to the controller as shown in the diagram below.



1.8 Ventilation Requirements

AmbiRad tube heaters can be operated as flued or unflued appliances in accordance with the relevant national requirements in the country of installation.

1.8.1 Unflued Radiant Heater

Radiant tube heaters can be operated as unflued appliances so that the concentration of Carbon Dioxide (CO₂) at positions where the air will be inhaled does not exceed 0.28%. BS EN 13410:2001 is a guide to achieving this requirement.

If the building air change rate exceeds 1.5 per hour or if the heat input is less than 5W/m³, no additional ventilation is required.

In addition to the ventilation requirements, consideration needs to be given to the possibility of condensation forming on cold surfaces.

It should be noted that the clearance distance around the burner increases when the unit is operated unflued (see section 1.6). It should be ensured that the combustion gases do not impinge on any combustible materials.

Mechanical Ventilation

Mechanical ventilation must be installed to meet a minimum of 1.5 air changes per hour using appropriately sized fans and interlocked with the heaters.

Natural Ventilation

BS EN 13410:2001 should be used to size air vents to provide adequate ventilation, an example of this calculation is given below:

Site Details:

20°C Internal Operating Temperature

0°C Outside Air Temperature

5m between high and low level vents

Following the sizing procedure in BS EN 13410:2001 gives an air exit velocity of 1.6m/s. This equates to a free area vent at both high level and low level of 17.36cm²/kW free area.

1.8.2 Flued Radiant Heater

In buildings having an air change rate of less than 0.5 per hour, additional mechanical or natural ventilation is required. For detailed information, please see BS6896:2005 section 5.2.2.2.1

Mechanical Ventilation

Mechanical ventilation must be installed to meet a minimum of 0.5 air changes per hour using appropriately sized fans and interlocked with the heaters.

Natural Ventilation

Low level ventilation openings with a free area of at least 2cm²/kW shall be provided. See section 5.2.2.2.2.1.

1.9 Flue and Combustion Air Inlet - Options

Dependent on the type of burner fitted to your heater it is possible to have configurations of flue and combustion air inlet options to those shown overleaf:

• Option 1

For burner with / without flue and / or optional ducted air inlet refer to Figure 6.

1.9.1 Important Information

1.9.1.1 Option 1

A suitable flue system complying with EN1856-1 (type T250 N1 D Vm L11040 O50) should be used.

Flue size 125mm diameter twin wall.

Flue systems can run either vertically or horizontally up to a **maximum length of 9.5m** (including up to 2 x 90° bends plus the terminal).

The minimum flue length shall be 1m.

The flue system **must be terminated in a vertical position** and in accordance with the British Standard Code of Practice BS 5440: Part 1 - Installation and maintenance of flues and ventilation for gas appliances of rated input not exceeding 70kW net (1st, 2nd and 3rd family gases), and the flue system manufacturers instructions as supplied with the flue.

1.9.2 Installation

Connection to an appliance which is not connected to the fuel supply may be carried out by a competent person. However, connection to an appliance that is connected to the fuel supply **must** be carried out by a registered installer.

If the flue passes through a wall, ceiling, or roof made from combustible material then it has to be sleeved so as to provide a minimum of a 50mm void between the exterior of the flue and the internal wall of the sleeve. A minimum of 50mm must be maintained as a clearance distance to all other combustible materials.

The manifold should be supported by chain, stainless steel flexible wire, or other flexible means from the roof structure to allow movement caused by thermal expansion.

The maximum distance between supports is 1.5m for horizontal runs.

Wall bands are not load bearing and give lateral support only. If used, wall bands should be fitted every 3m on vertical runs to ensure the system is rigidly held. The system should be braced immediately below passing through the roof line to ensure the flashing does not suffer lateral pressures.

The maximum height unsupported above the roof line is 1.5m. Where a joint is above the roofline it should be determined that in extreme wind conditions this joint would not be over exerted. If there is any doubt then a guy wire should be used. Beyond this guy wires should be installed every meter.

The POCED is capable of withstanding its own weight when installed in accordance with these instructions and the Regulations shown below.

The exhaust flue should be adequately supported from the building structure and installed in accordance with the British Standard Code of Practice BS 5440: Part 1: - Installation and maintenance of flues and ventilation for gas appliances of rated input not exceeding 70kW net (1st, 2nd and 3rd family gases), and the flue system manufacturers instructions as supplied with the flue.

See reference BS 6896: Condensate drain pipes must be protected against the effects of freezing.

1.9.3 Condensation

When designing the flue system the prevention of the formation and entrapment of condensation must be a key consideration.

1.9.4 Flue Connection

All pipe lengths and flue gas carrying components are joined together by a twist lock, bayonet system. The system should be installed with the visible male collar pointing upwards, this is reaffirmed by the directional arrow pointing upwards, indicating the directional flow of flue gases. Taping of the joints is unnecessary.

1.9.5 Ducted Air

To prevent water ingress on VTC models it is necessary to fit ducted air to the burner via the flange shown in Fig.7 on page 15 of this document

The ducted air flange is fitted with a flexible tube and secured with a hose clip as shown in the picture below.

The other end of the flexible hose connects with the solid tube of the fresh air intake and secured with a hose clip.

For dirty or polluted environments it is recommended that VT models are fitted with ducted fresh air.

Flange part No. **201447** and 3 off screws part No. **201091** are available from the manufacturer.



1.10 Technical Details.

Table 3 - General

No of Injectors	1
Gas Connection	½ in BSP Internal thread
Flue Nominal Bore mm (in)	125 (5)
Fan Type	202490
Fan Motor Details	230 volt 1 phase 50Hz
Fan Rating (A)	1.0

Table 4 - Natural Gas (G20)

Heater Model	Heat Input kW				Gas Flowrate (m³/hr)		Injector Pressure (mbar)		Injector Size (mm)
	Gross		Nett		High	Low	High	Low	
	High	Low	High	Low					
VT25UT	25.0	17.5	22.5	15.8	2.4	1.7	11.0	6.1	1.8
VT25LI8	25.0	17.5	22.5	15.8	2.4	1.7	10.7	6.0	1.8
VT25LI10-5	25.0	17.5	22.5	15.8	2.4	1.7	10.7	6.0	1.8

Table 5 - Propane Gas (G31)

Heater Model	Heat Input kW				Gas Flowrate (l/hr)		Injector Pressure (mbar)		Injector Size (mm)
	Gross		Nett		High	Low	High	Low	
	High	Low	High	Low					
VT25UT	25.0	17.5	23.1	16.2	3.5	2.5	14.9	7.7	1.3
VT25LI8	25.0	17.5	23.1	16.2	3.5	2.5	14.7	7.5	1.3
VT25LI10-5	25.0	17.5	23.1	16.2	3.5	2.5	14.7	7.5	1.3

Table 6 - Dimensional details

Heater Model	Size (h x l x w)	Weight (Kg)
VT(A)(C)25UT	240x5180 (unflued)x500	60
VT(A)(C)25LI8	390x7867 (unflued)x315	53
VT(A)(C)25LI10-5	390x10467 (unflued)x315	72

Figure 7. Flue/Terminal Attachment Linear Burners

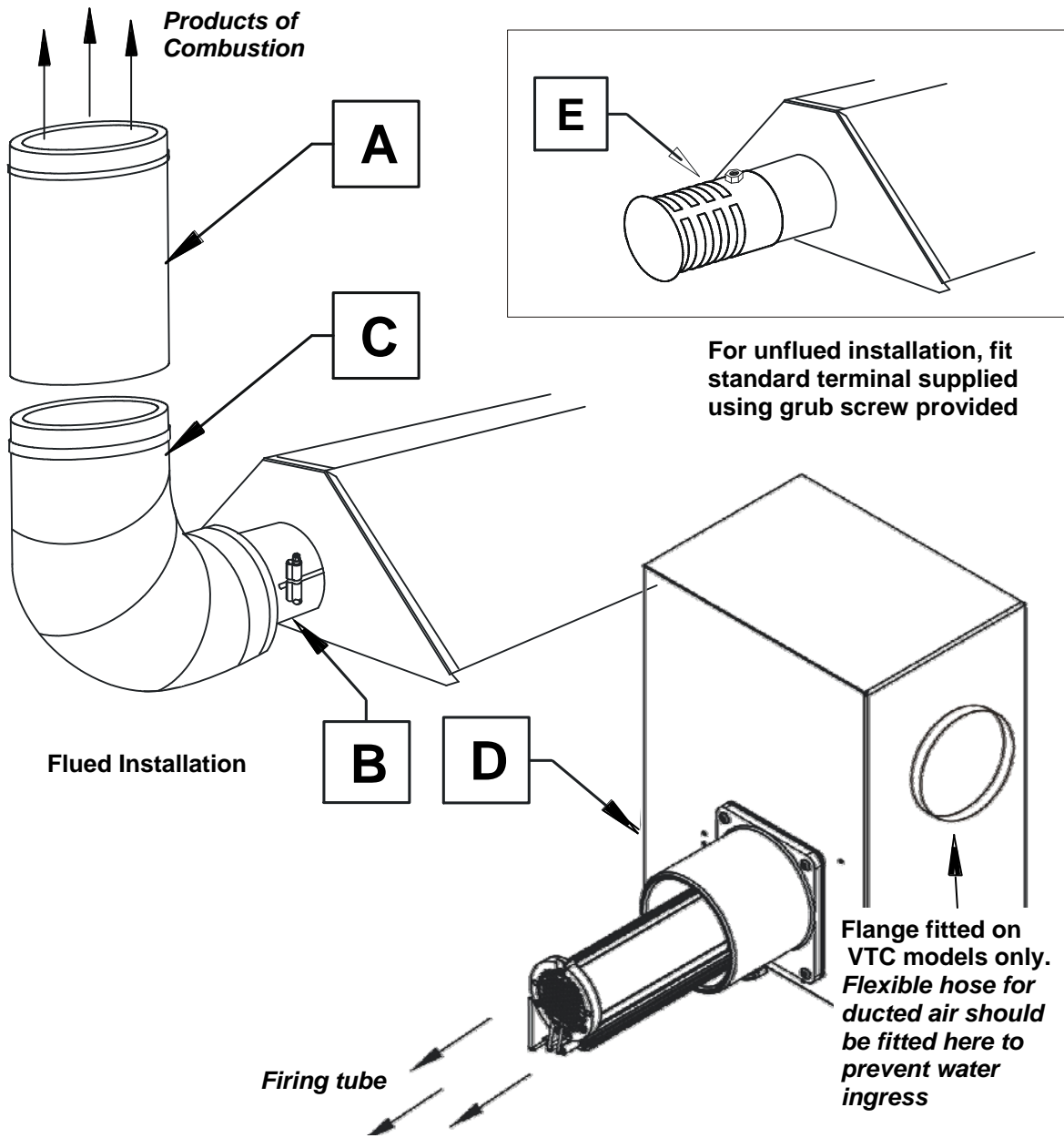

 Ventilation requirements are as detailed in section 1.9

 Ducted air must be used on VTC models, and in locations where there is airborne dust or where there is a polluted atmosphere e.g Chlorinated Vapours.

 Maximum length = 9m
 Minimum diameter = 100mm
 Maximum no of bends = 2

A	127mm (5ins) Twin Wall Flue System
B	Tube to Flue Adaptor 75mm 201881
C	Flue Bend 7166
D	Two Stage Burner
E	Standard end terminal (unflued)201866-SUB

 Maximum flue run = 9.5m @ Ø125mm
 Maximum no of bends = 2
 All flues must **terminate** vertically.
 For further information on flue runs, please refer to section 1.10.1 and BS 5440 pt.1

Figure 7a.

A	Standard end terminal (unflued)201866-SUB
B	Tube to Flue Coupler 75mm 201813
C	Flue Bend 202662
D	Two Stage Burner

Fit standard terminal supplied using grub screw provided

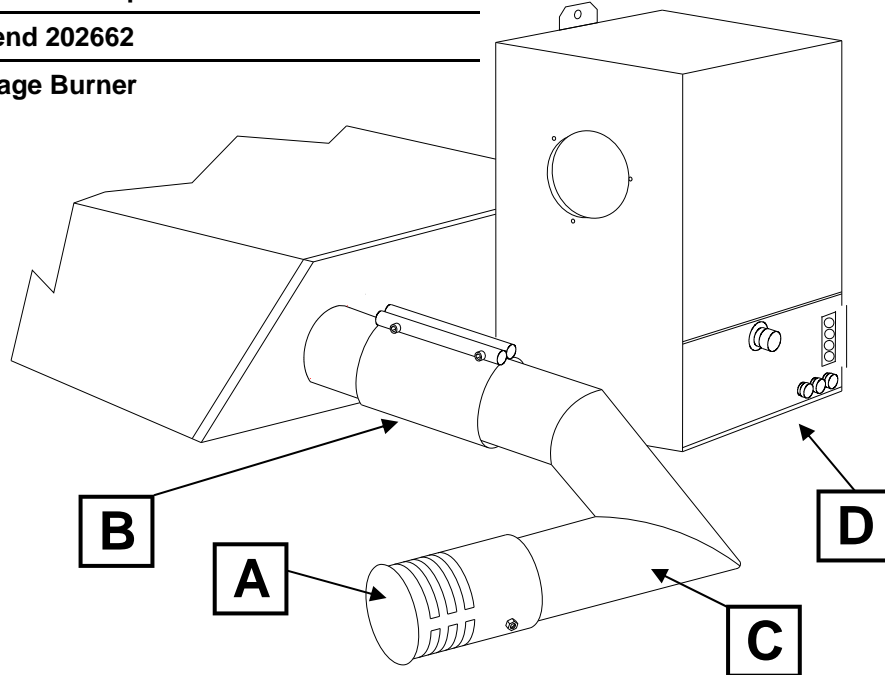
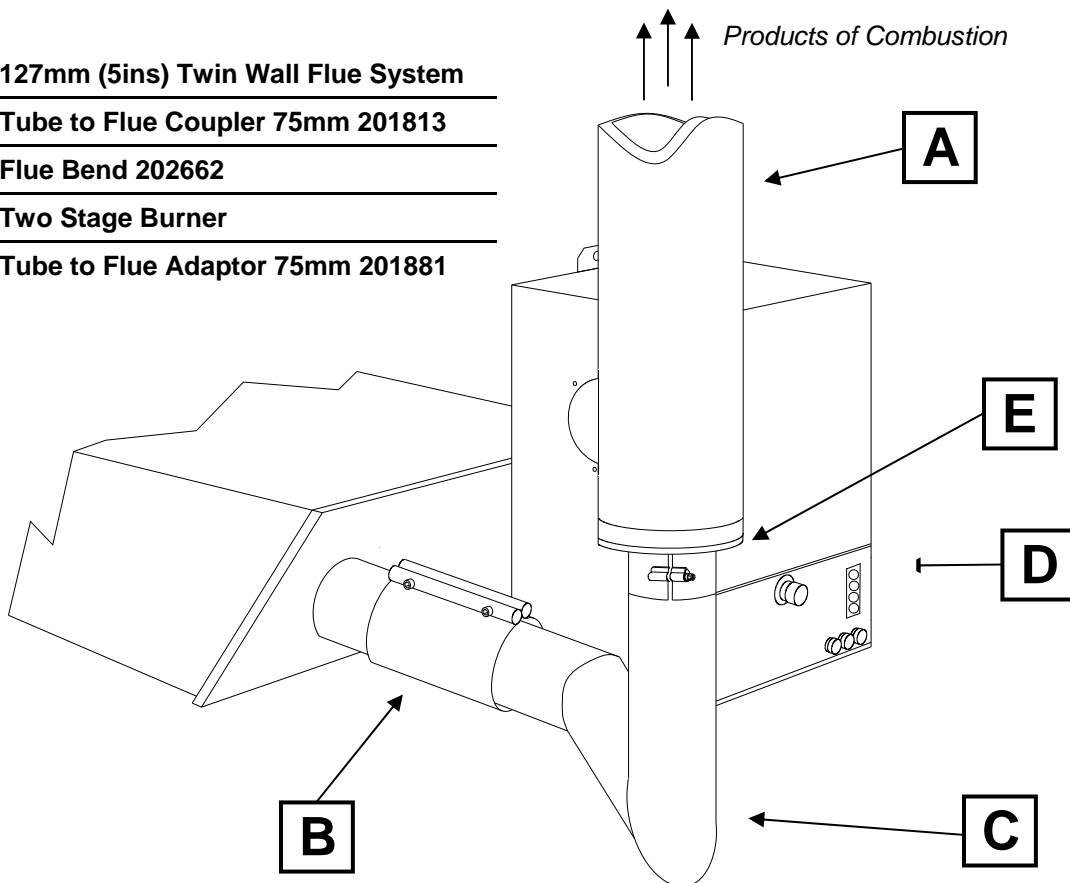



Figure 7b.

A	127mm (5ins) Twin Wall Flue System
B	Tube to Flue Coupler 75mm 201813
C	Flue Bend 202662
D	Two Stage Burner
E	Tube to Flue Adaptor 75mm 201881

Products of Combustion



2. Assembly Instructions.

 **PLEASE READ** this section prior to assembly to familiarise yourself with the components and tools you require at the various stages of assembly. Carefully open the packaging and check the contents against the parts and check list.

The manufacturer reserves the right to alter specifications without prior notice.

 Please ensure that all packaging is disposed of in a safe environmentally friendly way.

 For your own safety we recommend the use of safety boots and leather faced gloves when handling sharp or heavy items. The use of protective eye wear is also recommended.

2.1 Tools Required.

The following tools and equipment are advisable to complete the tasks laid out in this manual.



 Suitable alternative tools may be used.

2.2 Assembly Notes.

 **Please read** these assembly notes in conjunction with the correct assembly drawings (figs 9 to 11).

2.2.1 Tubes

Identify and position tubes on trestles. For aesthetics it is advisable to position the tube seam and coupling fastener so that these cannot be seen from beneath the heater. Mark out the position of the bracket centres from the dimensions shown on the assembly drawings.

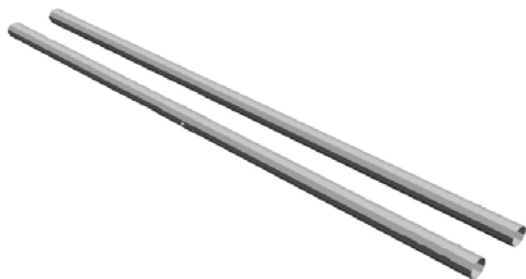

2.2.2 Turbulators

Insert turbulators into the tubes ensuring the correct length and quantity are inserted into their respective correctly identified tube as detailed in the assembly drawings.

2.2.3 Brackets

There can be two types of brackets supplied with these heaters:

- Type 'A' are suspending brackets with reflector fixing points.
- Type 'B' are suspending brackets with no fixing points.
- Type 'C' is a centre bracket to retain the reflector. (UT model only)

Slide the bracket assemblies along to the tubes to the marked positions in their correct order as detailed in the assembly drawings.

Tighten clamping 'U' bolt arrangement to tubes **ONLY WHERE STATED** on the assembly drawings.

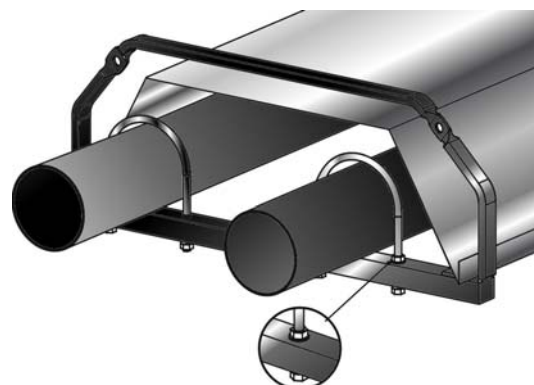

2.2.4 Couplers.

For VTLF tube heaters only. For joining radiant tubes, locate and position tube couplers at the end of the tube so that the socket heads are facing outwards. Tighten clamping bolt arrangement to secure ensuring the bolts are not over tightened.

For VTUT tube heaters only. For joining U bend, locate and position tube couplers at the end of the tubes so that the socket heads are facing outwards.

Do not fully tighten at this stage.



2.2.5 U Bend.

For VTUT tube heaters only. Slide U bend into the open end of the couplers. Tighten all four clamping bolts to provide a tight grip between tubes & U tube section.



To avoid damaging the heater whilst installing we recommend the heater chassis be suspended prior to fitting reflectors.

2.2.6 Reflectors.

After removing the protective plastic coating, slip the reflector through the brackets until the locating slots are aligned with the type A bracket fixing points.

Note:

UT models do not have type A brackets. The reflectors bolt to the central type C bracket. See Fig. 7 (assembly diagram)

Slide the next reflector through the brackets and overlap the existing reflector until the locating slots line up with the same bracket fixing points. Secure overlapped reflectors to bracket using M6 nuts, bolts and flat mud washers.

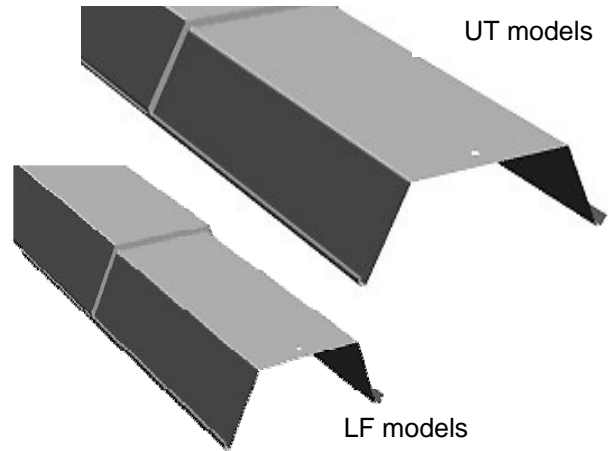

 All reflectors must be positioned/attached to the brackets exactly as detailed in the assembly drawings.

Remove the protective plastic coating.

2.2.7 End Caps.

On VTUT models only, position the end cap with no tube holes beneath the reflector profile at the U bend end with the end cap flanges facing inwards. Fasten to reflector using M5 pozi set pin and 'Z' clips. Position the end cap with tube holes beneath the reflector profile at the burner end with the end cap flanges facing inwards. Fasten to reflector using M5 pozi set pin and 'Z' clips.

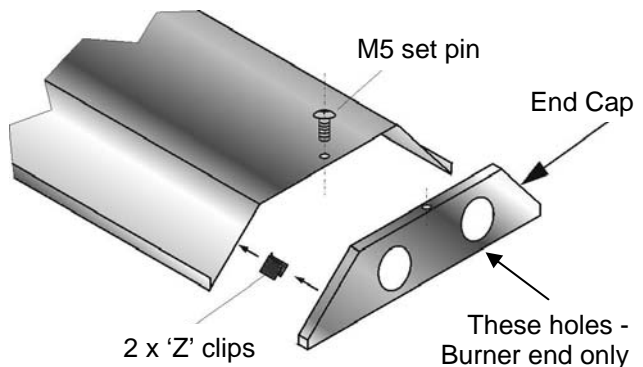

On VTLF models only, position ONE end cap beneath the reflector profile at the open end with the end cap flanges facing inwards. Fasten to reflector using 'Z' clips. Position the other end cap beneath the reflector profile at the burner end with the end cap flanges facing inwards. Fasten to reflector using 'Z' clips.

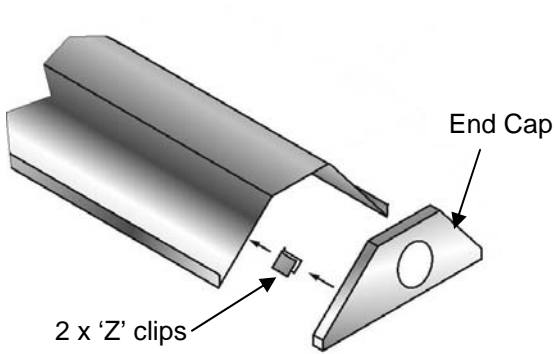

2.2.8 Burner Assembly.

On VTUT only, slide the burner assembly onto the **RIGHT HAND TUBE** when viewed from above, ensuring it is fully engaged. Secure with grub screws.

Do not silicone seal!

On VTFL only, slide the burner assembly onto the **INLET END OF THE TUBE** ensuring it is fully engaged. Secure with grub screws.

Do not silicone seal!



2.2.9 Flue/Terminal Outlet.

On VTFL Flued installations, locate adjustable tube-to-flue connection (supplied optionally) onto open ended tube. Rotate to required orientation. Secure with clamp screw.

Do not silicone seal!

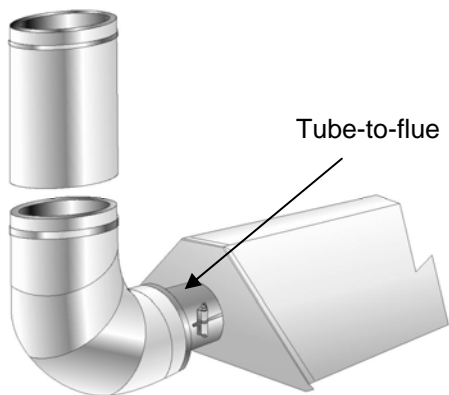

On VTFL Un-flued installations, locate standard terminal as supplied onto open ended tube. Secure with grub screw.

Do not silicone seal!

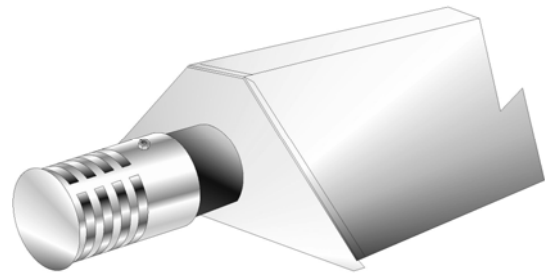

On VTUT Flued installations, fit flue bend to heater tube with coupler supplied. Fit adapter to flue bend then fit twin wall flue to adapter. *Do not silicone seal!*



On VTUT Unflued installations, fit flue bend to heater tube with coupler supplied. Fit standard terminal as supplied onto open ended tube. Secure with grub screw.

Do not silicone seal!

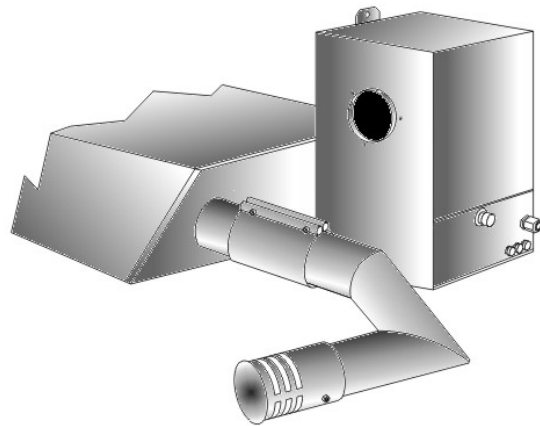

2.2.10 Detailed Assembly Drawings

The following pages show the technical dimensional details of the VT range of heaters. Please note the heater type, length and reference number from the delivery/advice note before identifying the correct model drawing.

Figure 7. Vision Heater Assembly: Models VTUT/VTAUT/VT CUT U tube 25kW.

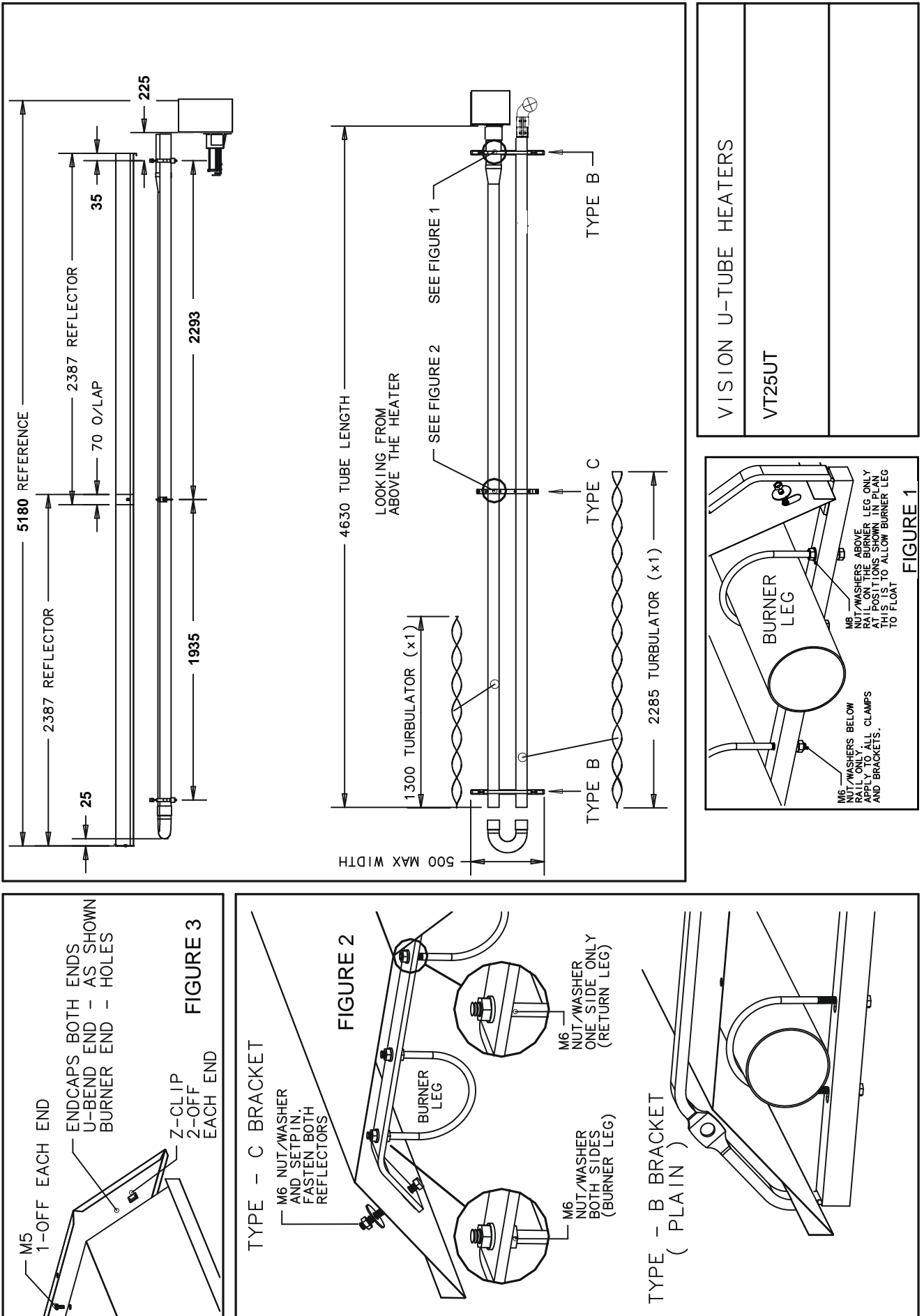
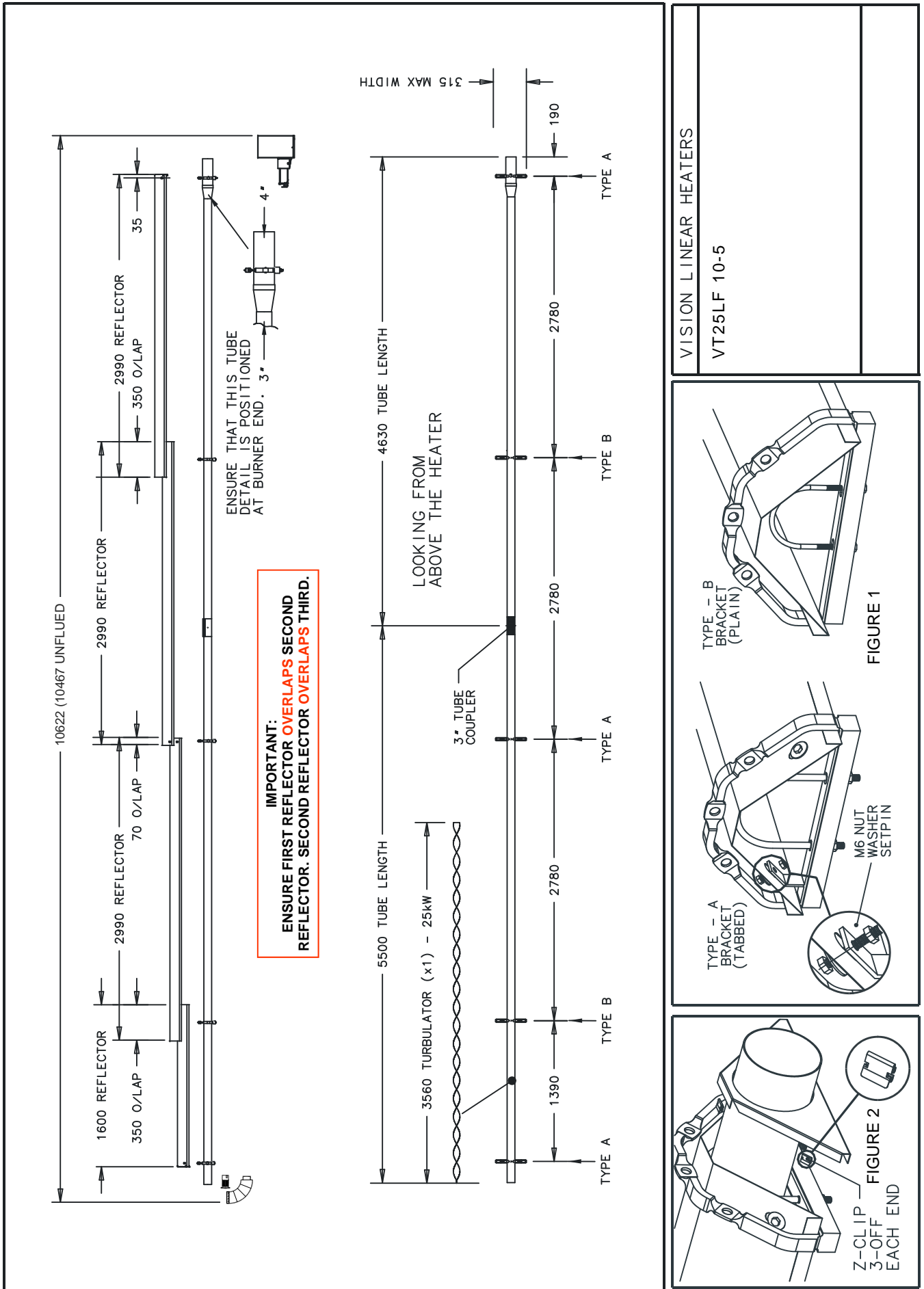

Figure 9. Vision Heater Assembly: Models VTLF/VTALF/VTCLF 25kW 10.5m - 75mm (3ins) Nom Dia.



VISION LINEAR HEATERS

VT25LF 10-5

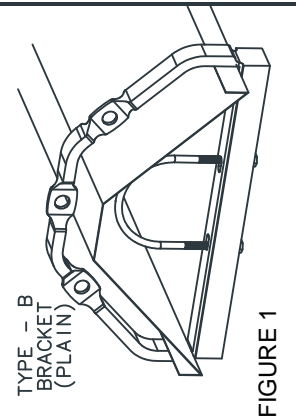
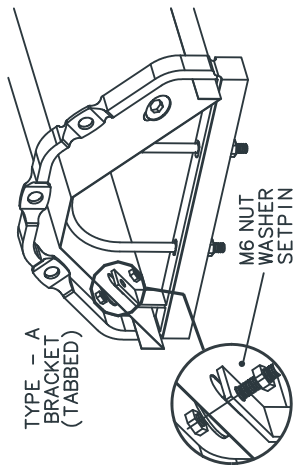

FIGURE 1



Z-CLIP 3-OFF EACH END

3. Commissioning Instructions.

! These appliances should be commissioned by a qualified engineer.

3.1 Tools Required.

to complete the tasks laid out in this manual.

The following tools & equipment are advisable



Suitable alternative tools may be used.

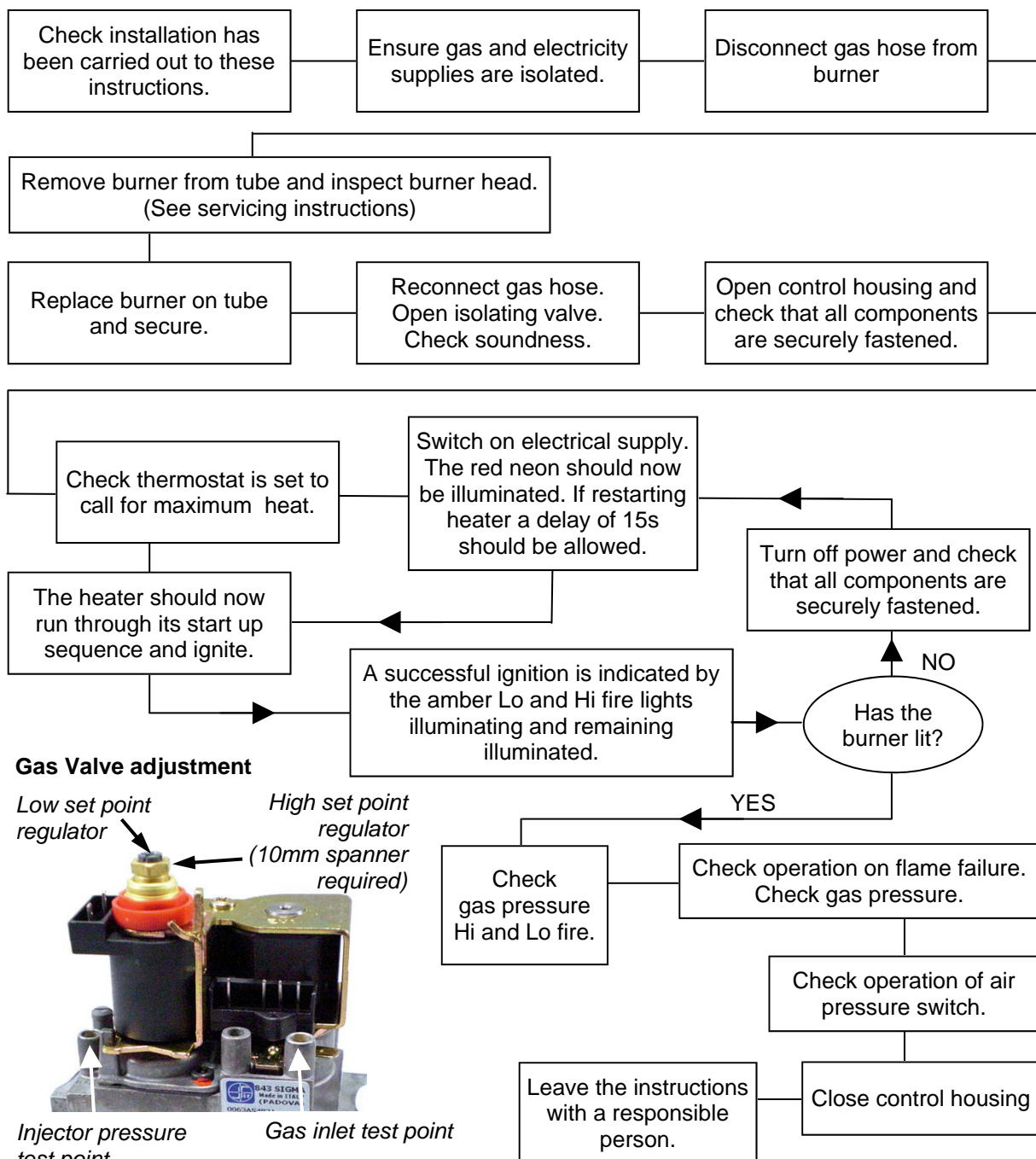

4. Servicing Instructions.

 These appliances should be serviced annually by a competent person to ensure safe and efficient operation. In exceptional dusty or polluted conditions more frequent servicing may be required. The manufacturer offers a maintenance service. Details available on request

4.1 Tools Required.



Suitable alternative tools may be used.

The following tools and equipment are advisable to complete the tasks laid out in this manual.



4.2 Burner Description.

Figure 10. Burner breakdown

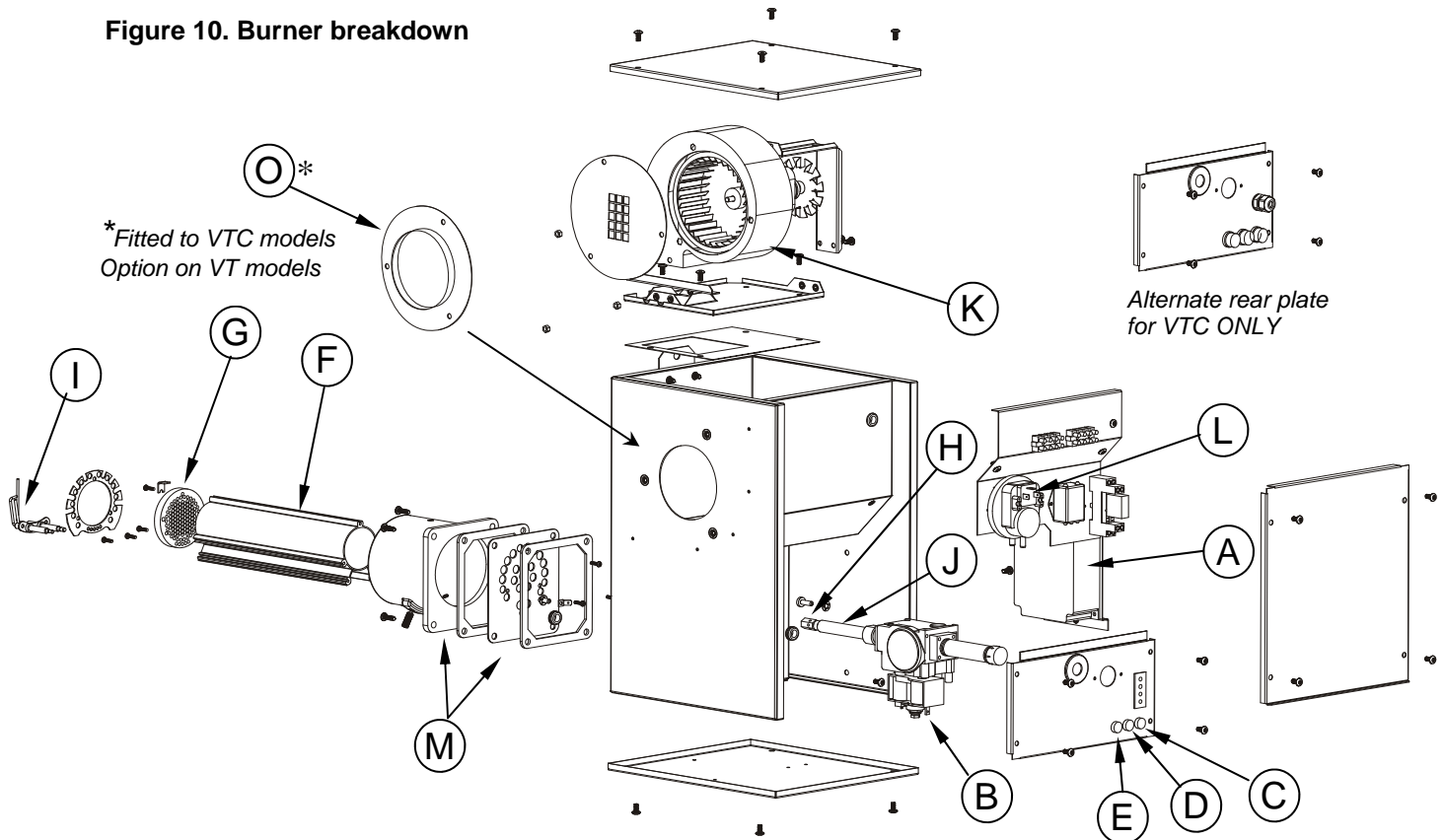

A	Ignition Controller	I	Igniter Assembly
B	Gas Valve	J	Jet Carrier
C	Power On Red LED	K	Combustion Fan
D	Low fire Amber LED	L	Pressure Switch
E	High fire Amber LED	M	Gaskets
F	Burner Tube	N	Ignition/rectification Leads (not shown)
G	Pepper Pot Head	O	Ducted air flange
H	Injector		

4.3 Burner Removal

 Step 1 Isolate power and gas supplies.

Step 2 Disconnect the external power/control connections as shown (VTC only). Disconnect external 4 way power/control plug from burner housing (VT only)



Step 3 Detach the gas supply as shown below, taking care to support the burner connection.



Step 4 If ducted air is connected, slacken hose clip and remove the flexible hose from the burner.



Step 5 Remove the support connected to the burner bracket. Slacken the set screws on the burner support casting to enable the burner to be removed from the radiant tube.



Step 6 Remove the burner and position the burner in a safe area to prevent the burner or components attached to the burner from falling to the ground.

4.4 Burner Gas Injector Servicing

Step 1.a Remove the 4 retaining screws, then remove the burner support casting and gasket.



Step 1.b The burner head assembly can be disconnected by separating the connectors of the ignition lead assembly and removing the earth lead and pressure switch silicon tube.



 Step 2 The gas injector can be inspected and replaced if contaminated or blocked.

When replacing the gas injector ensure approved thread sealant is used.

Step 3 Reconnect ignition leads and silicone tube to test nipple. Refit gasket and support casting.

4.5 Combustion Fan Servicing

Step 1 Remove the four top lid screws to reveal the combustion fan shown below.

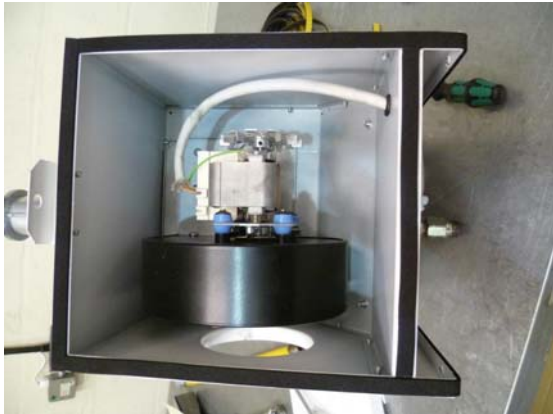

Step 2 Disconnect the fan cables after first noting their positions, then pull cable through to fan compartment.



Step 3 Remove the four fan fixing screws then withdraw the fan complete with mounting bracket.



Step 4 Remove fan orifice plate.

Step 5 Inspect the impeller and remove any dust with a soft brush.

Step 6 Remove any dust from fan scroll and from around the motor.

Step 7 Ensure the impeller rotates freely.

Step 8 Refit components.

4.6 Burner Head and Electrode Servicing

Step 1 Check the pepper pot burner head for contamination. If necessary this can be removed. See below.



This can be cleaned together with the inside of the burner head.

Step 2 The pepper pot burner head can be replaced ensuring the 5 holes on the outer ring are aligned alongside the probes.

Step 3 The condition of the igniter assembly can be checked for deterioration. However, we advise replacement at each service to ensure continued reliability. Detach the electrode assembly from the burner head by removing the two screws as shown and separating the igniter assembly lead connectors.



Step 4 Refit the electrode assembly and ensure the connections are secure to prevent incorrect sparking of the spark electrode.

Step 5 Check the positions and spark gap as shown in diagram below.

Step 6 The burner assembly is ready to refit after servicing the combustion fan and the radiant tube assembly.

4.7 Radiant Tube Servicing

Step 1 Brush any dust from the exterior of the tubes.

Step 2 Inspect the fan and burner tubes visually. If the tubes appear clean, skip to servicing the reflector.

Step 3 If required the interior of the tubes can then be cleaned using an industrial vacuum cleaner or by using long poles and a scraper.
Step 7 Refit components.

Step 4 Withdraw the turbulators from the appliance. Carefully noting their condition and position. Replace turbulators if necessary.



Step 5 The turbulators should be cleaned with a soft brush.



4.8 Reflector Servicing

The condition of the reflectors should be noted. If necessary the reflectors can be cleaned with a mild detergent. This can significantly improve the efficiency of the appliance.

4.9 Sweeping of Vent

Inspect the fresh air inlet duct and vent to ensure they are free from any blockage or obstruction. The air inlet terminal and vent terminal should be inspected to ensure they are not liable to obstruction.

4.10 Re-commissioning After Service

After servicing of the heater has been undertaken, it will be necessary to re-commission the heater as detailed in the commissioning chart in these instructions.

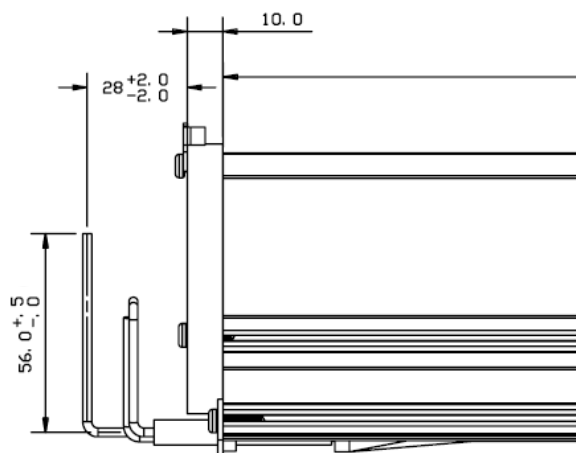
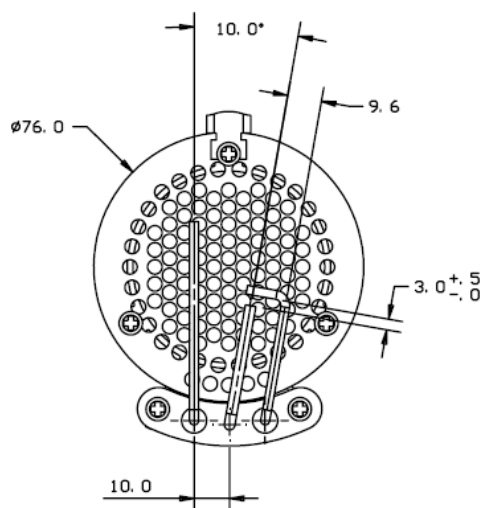

Figure 11. Burner head detail

5. Spare Parts.

Required Spares

In order to aid troubleshooting and servicing we recommend that the components shown in this section should be stocked.

! Note Any spare part components that are not approved by AmbiRad could invalidate the approval of the appliance and validity of the warranty.

Item	Description	Part No.	Item	Description	Part No.
	Ignition Controller	2015		Pressure Switch:	201676
	Two Stage Gas Valve 220/240	202538		Amber Neon (Hi and Lo fire)	2175
	EMC Filter	2136-SUB-LO		Red Neon (Power On)	2180
	230V Relay	2104		Amber Neon (Hi and Lo fire) VTC ONLY	900127
	Ignitor Assembly	201284		Red Neon (Power On) VTC ONLY	900128
	Pepperpot Head	200988		Combustion Fan	202490
	Injectors Natural Gas Propane	201007-18 201007-13		Gasket Set	201488-2
	Jet Carrier	200420	Cables:		
	Turbulators:			Spark Electrode (black)	900225-2
	VTUT			Rectification lead (purple)	900225-3
	Burner tube	6600T		Earth lead	900225-1
	Return tube	6614T			
	VTLF				
	Outlet tube	200414T			

6. Fault Finding Guide.

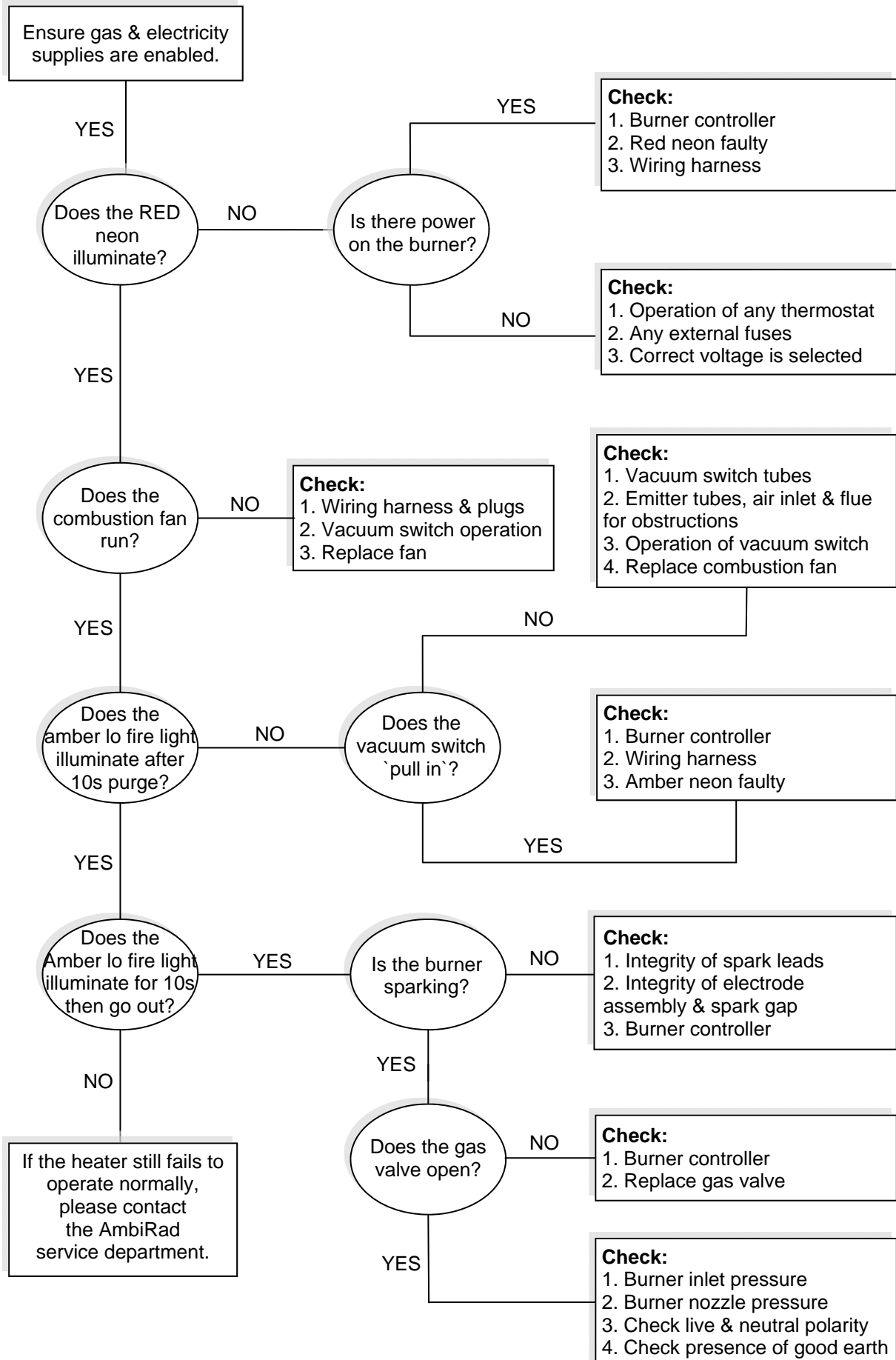

7. Replacing Parts.

7.1 Burner Controller Replacement

Step 1 Remove the four screws securing the lower burner access lid.

Step 2 Remove the two external screws attaching the controller to the burner housing and remove complete with bracket.



Step 3 Disconnect the HT Lead from burner controller.



Step 4 Disconnect burner controller from the wiring harness.

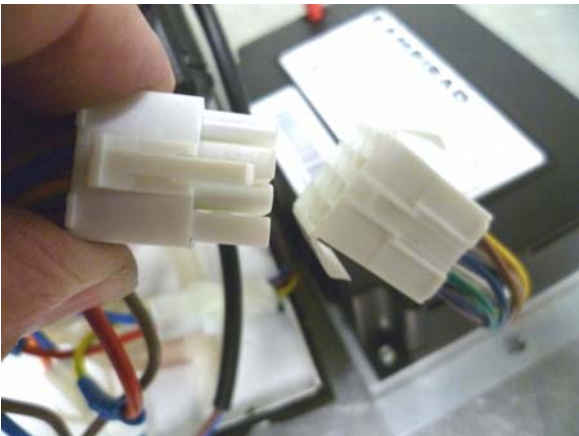

Step 5 Fit new burner controller.

Step 6 Refit HT leads and refit burner controller

to wiring harness.

Step 7 Close access door and test product .

7.2 Air Pressure Switch Replacement

Step 1 Disconnect the two silicone impulse tubes.



Step 2 Remove the two control chassis fixing screws (LH shown)



Step 3 Remove the two screws securing the air pressure switch from rear of the control chassis as shown.



Step 4 Remove spade terminal connections. The air pressure switch can now be removed.



Step 5 Fit the new air pressure switch ensuring the impulse tubes are connected as shown.

Step 6 Test product and close access doors.

7.3 Gas Valve Replacement

Step 1 Remove the burner assembly as described in section 4.3 Servicing.

Step 2 Remove the 4 screws holding the burner head onto the burner assembly.



Step 3 The burner head can now be detached by disconnecting the impulse tube and the burner head wiring.

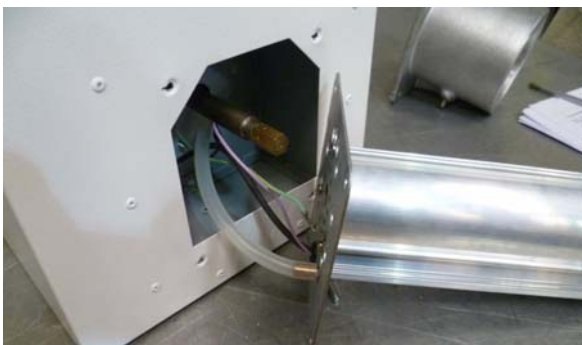

Step 4 Detach the four screws securing the front of the gas valve.



Step 5 Remove the four screws holding the rear burner plate in position.

Step 6 Remove the rear plate.



Step 7 Remove the gas valve electrical connections.

Step 8 The jet carrier and gas inlet can now be detached from the gas valve

Step 8 The gas valve can now be replaced.

Step 9 Refit all components in reverse order.

Step 10 Set gas burner pressure as per data badge to ensure reliable burner performance.

Step 11 Refit access covers and test product.

8. User & Operating Instructions.

8.1 To Start the Heater

1. Ensure gas supply is turned on.
2. Electrical supply to the controls is on.
3. Ensure that the controls are correctly set i.e.;

 - Clock is correctly set.
 - Heater program is correctly set.
 - Required room temp is correctly set

4. Once the heating controller 'calls for heat' power will be supplied to the heater(s). The red power on neon will then illuminate.
5. After a pre-purge period of 10 seconds the burner will ignite and the amber low fire neon will then illuminate. If the heat demand is not achieved on low fire, then the amber high fire neon will illuminate.
6. If lockout occurs press the lockout reset button (if available), or switch off electrical supply and restart after 15 seconds.
7. If lockout occurs three times consecutively switch off and isolate the gas and electricity supplies.
Contact the AmbiRad Service department.

8.2. To Switch Off Heater

1. Switch off electrical supply to the heater. The burner will stop and the fan will shut off.
2. If the heater is to be switched off for periods in excess of one week it is highly

recommended that both the gas and the electrical supplies are turned off.

8.3. Routine Maintenance between Service Intervals

After ensuring that the heater is cold and mains electricity isolated, cleaning of the reflectors with a soft cloth and a mild detergent (non solvent based cleaners only) in water can be undertaken.

Additional removal of dust from the radiant tubes and burner can be undertaken.

8.4 Frequency of Servicing

The manufacturer recommends that to ensure continued efficient and safe operation of the appliance, the heater is serviced annually by a competent person, e.g. every year in normal working conditions, but in exceptionally dusty or polluted conditions more frequent servicing may be required.

The manufacturer offers a maintenance service. Details are available on request.

For Service requirements, please contact AmbiRad.

For further technical and service support visit our Support Information Database at www.s-i-d.co.uk



NORTEK GLOBAL HVAC (UK) LTD
Fens Pool Avenue
Brierley Hill
West Midlands DY5 1QA
United Kingdom

Tel: 01384 489 250
Fax: 01384 489 707

ambiradsales@nortek.com
www.ambirad.co.uk