

## **GAS FIRED AIR HEATERS TYPE UCE/J**

Centrifugal Fanned Forced Convection Appliances with  
Thermal Electric Burner Control for use as:  
Type B11 Open flue Appliances

May be used with a "Euroventer" Flue Gas Fan as:  
Type B14 Appliances

This document applies to UCE/J appliances with:  
Thermoelectric or Hot Surface Ignition burner controls

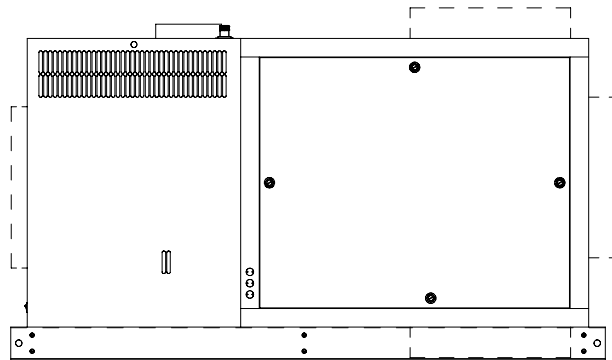

**These appliances meet the following EC Directives:**

<b>Dir. CE 90/396/EEC</b>	<b>GAD</b>
<b>Dir. CE 89/336/EEC</b>	<b>EMC</b>
<b>Dir. CE 89/392/EEC</b>	<b>MD</b>
<b>Dir. CE 73/ 23/EEC</b>	<b>LVD</b>

Please read this document carefully before commencing the installation and leave it with the user or attached to the appliance or gas service meter after installation.

**AmbiRad Limited, Fens Pool Avenue, Brierley Hill, West Midlands DY5 1QA (United Kingdom)**  
**Tel : 01384 489700**

**fax : 01384 489707**

1.	General .....	2
2.	Technical data .....	3
3.	Dimensions .....	4
4.	Installing.....	5
5.	Air supply requirements .....	8
6.	Flue system .....	9
7.	Gas connection.....	11
8.	Electrical connection.....	11
9.	Commissioning .....	12
10.	Servicing .....	16
11.	Short parts listing .....	21
12.	Gas conversion.....	22
13.	Fault finding .....	23
14.	Health and Safety information .....	24
15.	User instructions .....	25

N.B. If optional equipment is supplied with this appliance please refer to the additional instructions supplied with the option.

## 1. GENERAL

- |   |   |
|---|---|
| <p>1.1 Before installation, check that the appliance as described on the packaging label is in accordance with the correct type and model as specified on the data plate and complies with your customer order.</p> <p>1.2 After unpacking the appliance, leave it fastened to the wooden pallet until it has been suspended or until just before base mounting. This affords protection to the painted underside which is normally exposed to view after installation.</p> <p>1.3 Please read this document before commencing installation.</p> <p>1.4 These instructions are only valid for the country of use indicated on the appliance i.e.: GB - IE. If these symbols are not shown, it is necessary to obtain appropriate technical instructions which will provide information concerning the necessary modification of the appliance for the conditions of use in the country concerned. Such instructions may be obtained upon request from your supplier.</p> <p>1.5 Check that the local distribution conditions of electricity supply, type of gas and pressure, and adjustment of the appliance are compatible.</p> <p>1.6 When installed in Great Britain the total installation must comply with the requirements and recommendations of British Standard BS 6230 1991. "Installation of Gas Fired Forced Convection Air Heaters for Commercial and Industrial Space Heating".<br/>The Installation must also be in accordance with the relevant requirements of "The Gas Safety (Installation and Use regulations) and (Amendment Regulations 1990)" and The "Building" and "Electrical Regulations" (in GB the IEE Regulations).<br/>The requirements of the "Local Building Standards Office", the premises "Insurance" undertaking and the "Fire Office" must also be observed.</p> | <p>1.7 Unauthorized modification of this appliance or departure from use in the manner for which it was intended by the manufacturer or installation in a manner contrary to these instructions, may constitute a hazard and jeopardize all warranties. Deviations should only be carried out after formal consent has been obtained from the manufacturer.</p> <p>1.8 Ensure the environment in which the air heater will be installed will not create a hazard i.e. where excessive (volatile) dust, flammable or corrosive substances and/or vapours and combustible materials may be present.</p> <p>1.9 These appliances have been tested, and set according to the data plate before leaving the factory.</p> |
|---|---|

## 2. TECHNICAL DATA

**Table 1. APPLIANCE DATA**

Type UC E/J.			25	30	35	45	55	75	95
Gas category 'Cat.'			<b>II<sub>2</sub>H<sub>3+</sub></b>						
Air supply and flue type			B11 or B14 <sup>1</sup>						
Heat input (Hs) 'Qn'	kW		30,28	34,94	43,26	52,00	64,67	88,96	118,7
Heat input (Hi) 'Qn'	kW		27,30	31,50	39,00	46,90	58,30	80,20	107,0
High heat output	kW		23,8	27,5	34,2	40,8	50,8	69,9	93,2
Number of jets			4	5	7		9	12	16
Jet size	natural gas	Ø mm	2,4		2,2	2,4			2,6
	propane/butane	Ø mm	1,35	1,30	1,25	1,35			1,40
Gas supply pressure 'P' <sup>2</sup>	natural gas	mbar	<b>(GB) = 17,5 (IE) = 20,0</b>						
	propane	mbar	37,0						
	butane	mbar	28,0						
Burner pressure	natural gas	mbar	8,4						6,0
Gas consumption	natural gas <sup>3</sup>	m <sup>3</sup> /h	2,89	3,33	4,13	4,96	6,17	8,49	11,33
	butane G30	kg/h	2,21	2,55	3,15	3,80	4,72	6,49	8,66
	propane G31	kg/h	2,16	2,49	3,09	3,71	4,62	6,35	8,48
Gas service connection (not supply line size)			Rc :						
Electrical service (protection class IP 20)			230/240V 1 N ~ 50 Hz						
Weight net	kg		155	188	219		271	295	350
Weight shipping	kg		172	216	240		296	325	385
<b>UCE/J STANDARD AIR FLOW - FREE BLOWING - ZERO STATIC PRESSURE</b>									
Temperature rise ΔT (" 1)	K		33	31	27	32	31	32	
Air volume @ 15°C	m <sup>3</sup> /h		2100	2600	3700		4200	6300	8400
Mounting height <sup>4</sup>	m								
Throw (terminal V <sub>0</sub> to 0,5 m/s) <sup>5</sup>	#m		20		31	32	37	46	
Sound pressure level L <sub>p</sub> <sup>6</sup>	dB(A)		55	56	55		59		60
Fan motor rating	kW		0,18	0,25			0,37	0,55	0,75
Total electric rating <sup>7</sup>	kW		0,36	0,41			0,54	0,73	1,00

- 1 Category B14 only applies when used with a "EUROVENTER" flue gas fan
- 2 Maximum gas pressure at inlet to appliance = 50,0 mbar
- 3 Natural gas G 20, calorific heating value 10,48 kWh/m<sup>3</sup> on Hs @ 15 °C & 1013 mbar  
Propane G 31, calorific heating value 14,0 kWh/kg. Butane G 30, calorific heating value 13,7 kWh/kg
- 4 To underside of air heater
- 5 Isothermic condition (20°C), Louvres zero deflection
- 6 At distance of 5.0 m, Q = 2, A = 160 2m5, louvres zero deflection, isothermic condition,
- 7 Total electrical rating for appliances with hot surface ignition is exceeded by 130 W for +/- 30s at start up

**For all air flow duties and performance consult sales bulletin Document reference: FAN00049503**

**Figure 1. DIMENSIONS**

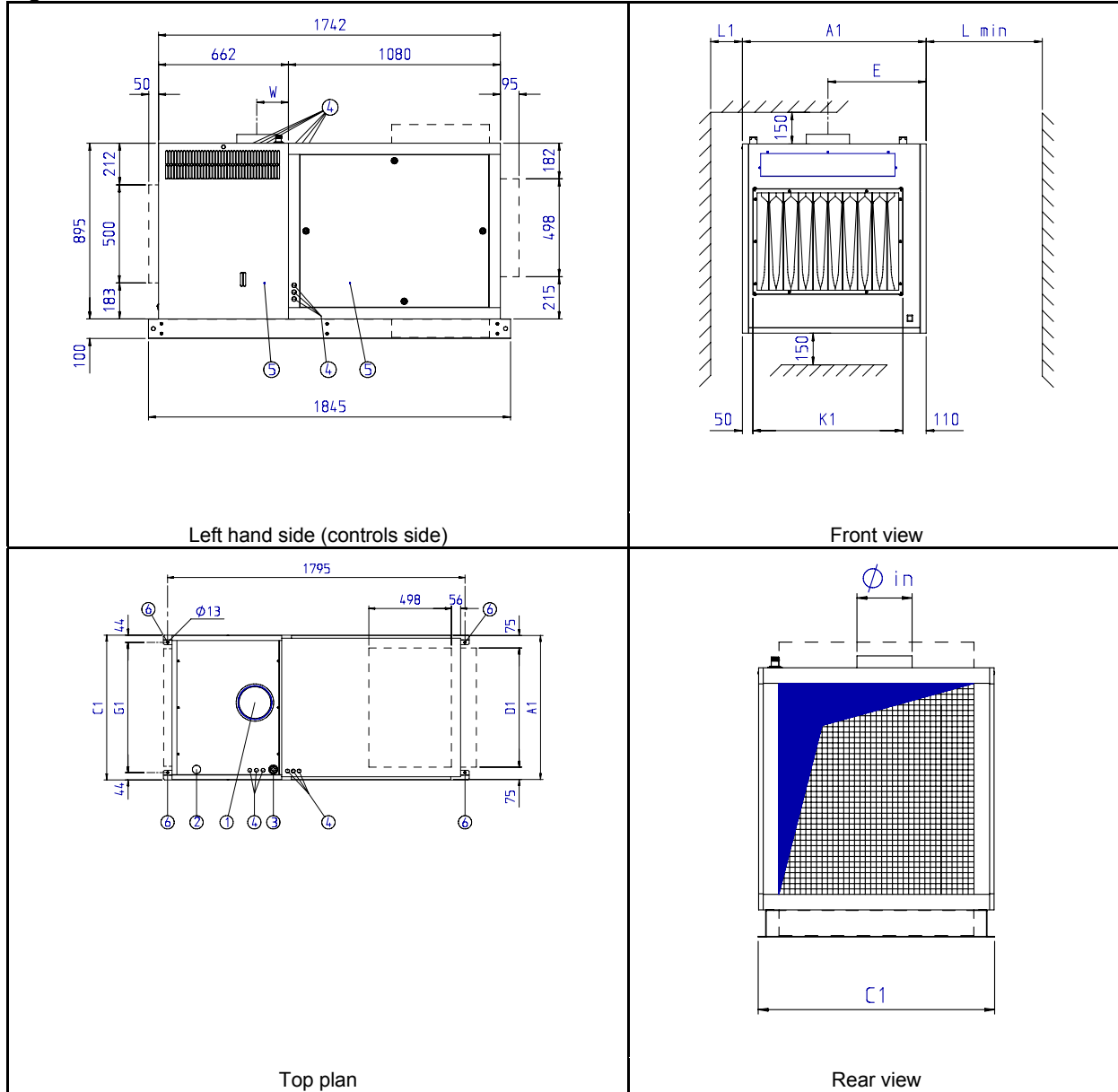

**Legend figure 1**

- |  |  |
|--|--|
| 1. Flue socket                         | 4. Electrical and Controls connections |
| 2. Gas connection Thermoelectric       | 5. Service and User access panels      |
| 3. Gas connection Hot Surface Ignition | 6. Suspension points                   |

**Table 2. DIMENSIONS REFERENCE FIGURE 1**

MODEL	UCE/J	25	30	35	45	55	75	95
A1 Width of appliance		520	590	730		870	1080	1360
C1 Width overall base frame		524	594	734		874	1084	1364
D1 Width of inlet air duct spigot OA		370	440	580		720	930	1210
E Flue centres		290	325	395		465	570	710
Flue internal $\varnothing$	mm	130	153	181		202	202	252
G1 Width of suspension points centres		436	506	646		786	996	1276
K1 Width of warm air outlet duct spigot OA		360	430	570		710	920	1200
W Centre of flue to cabinet divider panel		127	137	151		162	162	169

### 3. INSTALLING

- 3.1 The UCE/J air heater may be installed in a suspended manner using the suspension points provided in the base frame of the appliance. These air heaters may be base mounted. Ensure that the air heater is secured to any base mounting arrangement. Ensure that the structural elements of the building are adequate to carry the weight of the appliance and its ancillary components i.e. the flue system. If suspended the appliance should remain rigid so as not to impose a strain on the services connected to the appliance.
- 3.2 Ensure that sufficient space around the air heater is maintained for servicing and that the appliance is not sited where it may suffer from damage by, e.g. fork lift trucks.
- 3.3 Adequate clearance from combustible materials must be maintained between the appliance and its flue system.
- 3.4 A minimum distance of 300 mm must be allowed at the front of the appliance between any surface that will obstruct the free passage flue products spillage from the down draught diverter slot which is located directly above the warm air outlet from the air heater.
- 3.5 The appliance must be installed in a level plain both laterally and horizontally.
- 3.6 UCE/J air heaters are open flue natural draught appliances, it is therefore, important that they are installed in a draught free zone i.e. away from doors etc. Consideration must be given to the effects that any power extraction might have on the buildings natural pressure condition. The appliance flue will act as a pressure relief in the event that a negative pressure exists within the space where the air heater is installed.

**Figure 2** **INSTALLATION CLEARANCES**

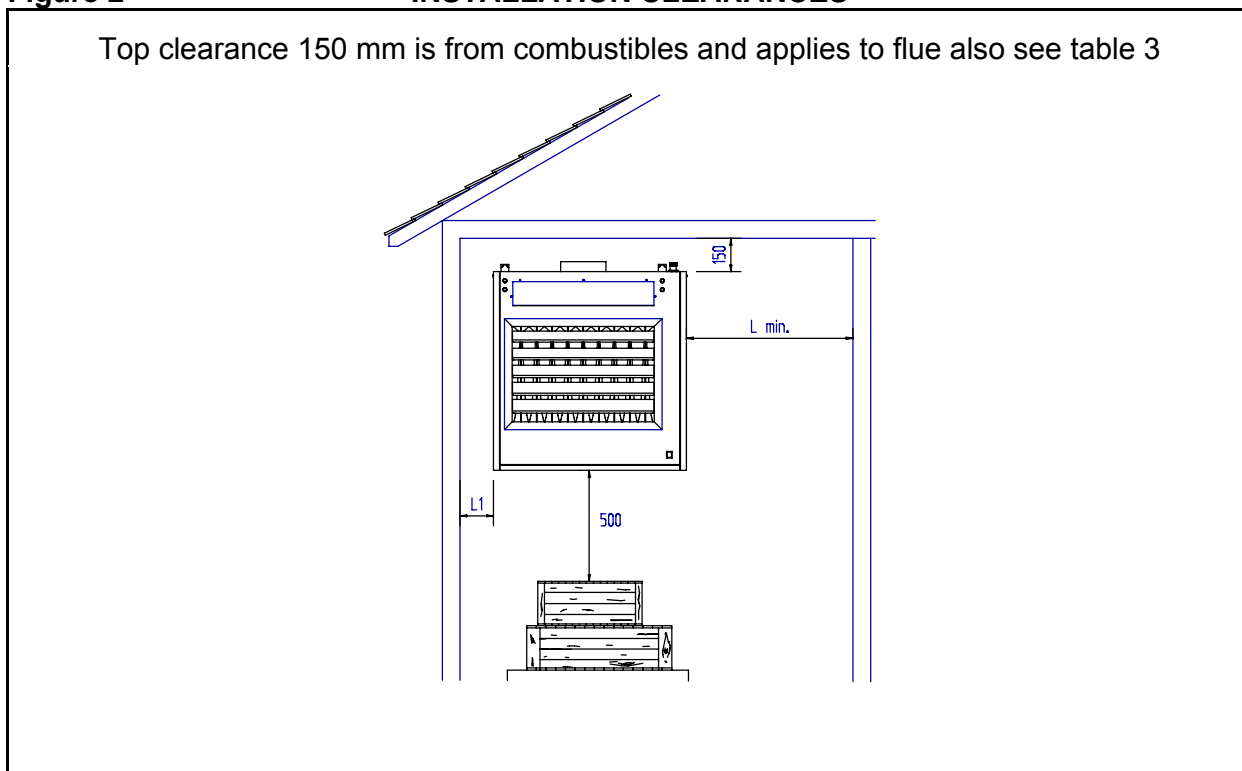

**Table 3** **DIMENSIONS REFERENCE FIGURE 2**

UC ...	25 E/J	30 E/J	35 E/J	45 E/J	55 E/J	75 E/J	95 E/J
<b>L minimum</b>	550	620	750		900	1100	1400
<b>L1 Opposite side</b>	150					300	

3.7 When transporting the appliance after it has been unpacked i.e. For lifting etc. Note the restrictions and recommendations indicated in figure 3.

3.8 The base frame contains an internal support member which acts as a lifting fulcrum point to prevent damage to the underside of the appliance by lifting forks.

**Figure 3. Appliance handling criteria**

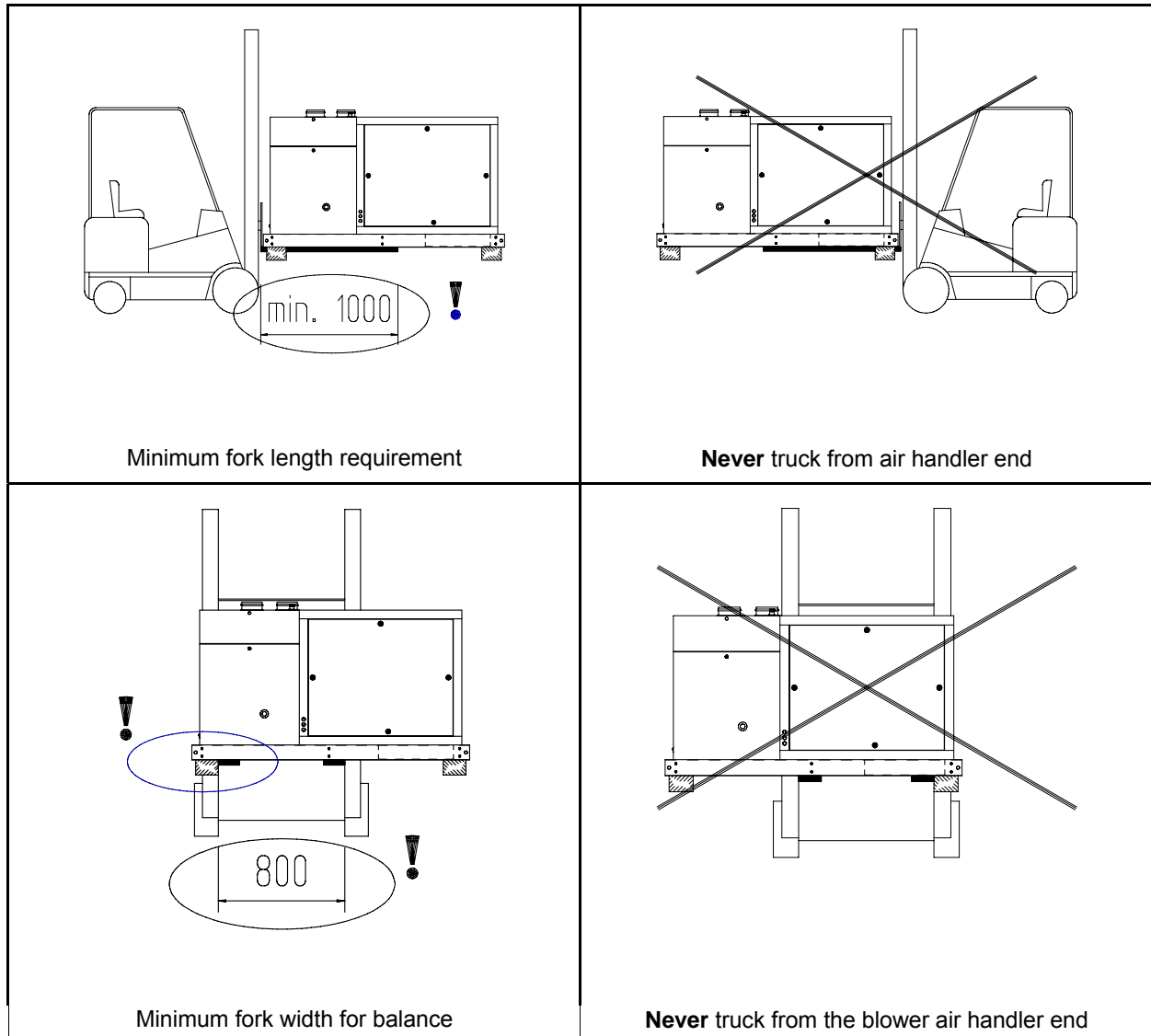

**3.9 DUCT CONNECTIONS**

The UCE/J series air heaters are designed to be used in conjunction with intake and or discharge ducting. A positive seal should be made between any ducting and the air heater. A flexible connection is desirable to eliminate transmission of noise and to take account of thermal expansion.

Figure 4 illustrates a method of connection between the appliance and the duct using a proprietary patented connection system.

3.10 Consideration should be given to the application of duct fittings directly connected to the appliance. Air inlet and outlet elbows, transitions etc. should be designed to ensure an unrestricted and turbulent free air flow. This requirement is to ensure that an even air temperature is maintained when leaving the appliance thus eliminating heat exchanger "hot-spots" and nuisance shut-down of the burner due to over heating.

**Figure 4. Recommended procedure and method for connection of ductwork and transitions to the air heaters using a typical proprietary flange system.**

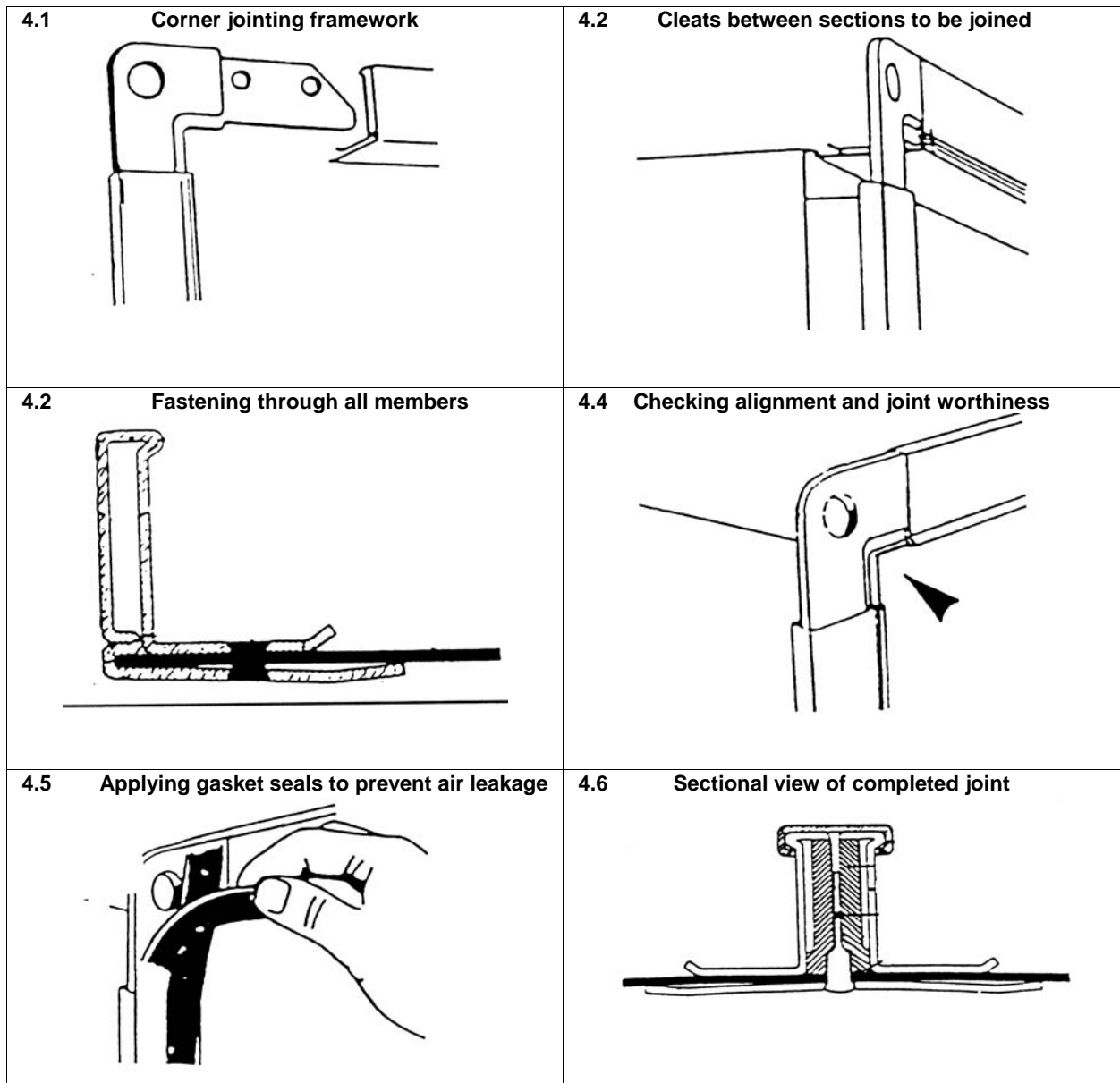

**Legend: Figure 4.**

- 4.1 Cut and assemble flange into frame to suit opening
- 4.2 Check dimensions and position on duct spigot
- 4.3 Ensuring flange is mated correctly before fastening

- 4.4 Checking location after positioning
- 4.5 Applying sealing gasket
- 4.6 Sectional view of completed joint

## 4. AIR SUPPLY for COMBUSTION & VENTILATION

4.1 It is essential that sufficient fresh air is provided for combustion and room ventilation. Most traditional building constructions have a natural air change rate of at least 0.5/h. Where it is known that the air change rate is at least 0.5/h and where the volume of the heated space is greater than 4.7m<sup>3</sup>; per kW of total rated heat input, additional ventilation is not required.

4.2 **Table 4.**  
**Building volume limits for UC Air Heaters based upon 4.7m<sup>3</sup> per kW of rated heat input for one air heater only.**

UC Model	Heat Input kW	Room Volume m <sup>3</sup>
25	30.28	142
30	34.94	165
35	43.26	203
45	52.00	245
55	64.67	304
75	88.96	418
95	118.70	558

If the minima volumes stated above exist together with appropriate similar allowances for other combustion plant that may be installed in the same space or zone, then additional ventilation is not required.

4.3 Where it is known that the air change rate is less than 0.5/h or where the building volume is less than 4.7m<sup>3</sup>; per kW of heat input, ventilation grilles must be provided at low level i.e. below the level of the appliance flue connection. In cases where doubt exists over the air change rate ventilation should be provided.

For air heaters of heat input less than 60 kW the total minimum free area shall not be less than 4.5 cm<sup>5</sup> per kW of total rated heat input as table 5 below.

For our heaters of heat input 60 kW or more the total minimum free area shall not be less than 270 cm<sup>5</sup> plus 2.25 cm<sup>5</sup> per kW in excess of the 60 kW rated heat input.

4.4 **Table 5. Air supply requirement for combustion and appliance ventilation**

UC Model	Heat Input kW	Low level cm <sup>2</sup>	
[60 kW	25	30,28	140
	30	34,94	160
	35	43,26	200
	45	52.00	240
μ 60 kW	55	64,70	290
	75	88,85	340
	95	118,70	410

**Note :** Ventilation grilles must be installed so that air is drawn directly from outdoors. In the event that communication from the space where the heater is installed to outdoors is via another room then the route to outdoors must be ducted through the communication area.

The grille velocity for all air supply must not exceed 2.0 m/s. Grilles should be sited where they cannot easily be blocked or flooded. Notices should be provided advising about the need to keep air supply grilles unobstructed.

4.5 Where mechanical ventilation is used it shall be by mechanical inlet with either mechanical or natural extraction. Automatic means of control such as interlocks must be provided. The function of other ventilation plant in the zone must be taken into account. At no time should it be possible to create a negative pressure in the zone as this will lead to a hazardous situation whereby the air heater flue will act as a pressure relief.

4.6 Normally UCE/J air heaters which are installed to be used in the free blowing mode, i.e. without discharge air ducting when installed within the room to be heated. If it is necessary to install the air heater in a separate room and blow the air into an adjoining room, provision for return air must be ducted to the appliance.

UCE/J air heaters may be used for fresh air and/or return air as combined heating/ventilation appliances.

## 5. FLUE SYSTEM

- 5.1 UC air heaters must be connected to a flue system venting the products of combustion directly to outdoors.

Flue systems must be installed in accordance with the rules in force taking into account the location of flue termination relative to the construction elements of the building, i.e. windows, roof levels, etc., and in accordance with statutory requirements.

Wherever possible a straight length of at least 600mm should be fitted to the appliance prior to any flue bend.

- 5.2 The products of combustion may reach a temperature of 230°C. We recommend that appliances are connected to individual flues sized in accordance with the diameter appropriate to the appliance flue connection socket.

Flues must be terminated with an approved terminal fitting.

- 5.3 A minimum length of 2.0 m is required to ensure a good flue draught condition.

- 5.4 Where it is necessary to flue more than one appliance into a common flue as fig.7 then the flue should be sized in accordance with the following formula:

$$D_1 = \sqrt{D_2^2 + 0.5 D_3^2}$$

Where:

$D_1$  = new flue size required

$D_2$  = diameter of largest flue

$D_3$  = diameter of additional flue

**Never** connect an additional flue to a main stack at a 90° angle an inclined N piece must be used.

- 5.5 It is not recommended to install the flue directly into the appliance flue socket but to use a stopped tee piece following a bend off of the air heater. This practice prevents ingress of water into the appliance and affords the facility to connect to a drain to evacuate water and condensation should this occur. Figure 5 shows the method recommended.

- 5.6 If it is necessary to include horizontal runs of flue within the system, then the horizontal section of flue should be installed with a positive rise away from the appliance of at least 1E or 17 mm per metre run until the vertical section.

A vertical rise from the appliance to the terminal point of 2.0 X the horizontal length must be maintained as indicated in figure 6.

- 5.7 The use of twin wall flue should be considered if condensation in the flue system is a possibility.

- 5.8 Difficult flue systems may be installed with a "EUROVENTER"

**NOTE: FIGURES 5,6 & 7 DEPICT UCA AIR HEATERS SAME FLUE DATA APPLIES FOR UCE/J MODELS**

**Figure 5. RECOMMENDED FLUE CONNECTION**

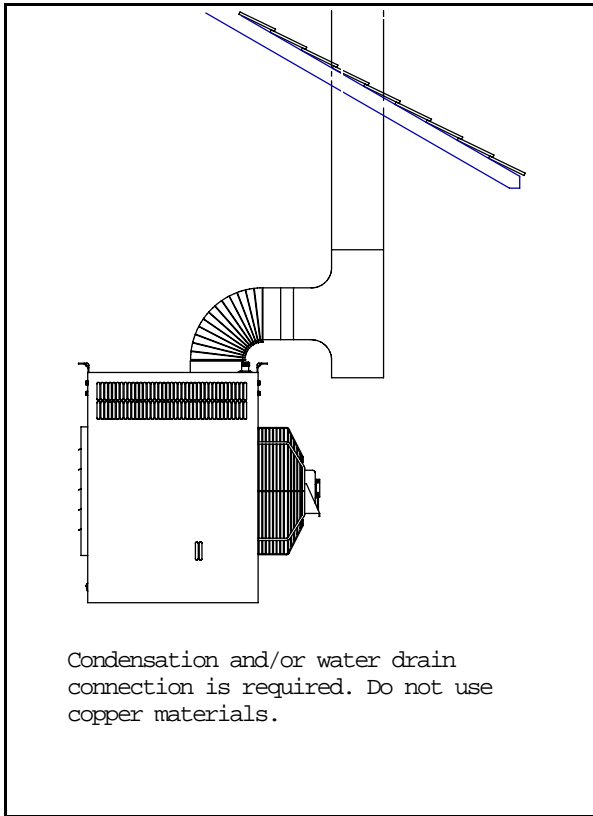

**Figure 6. HORIZONTAL FLUE CRITERIA**

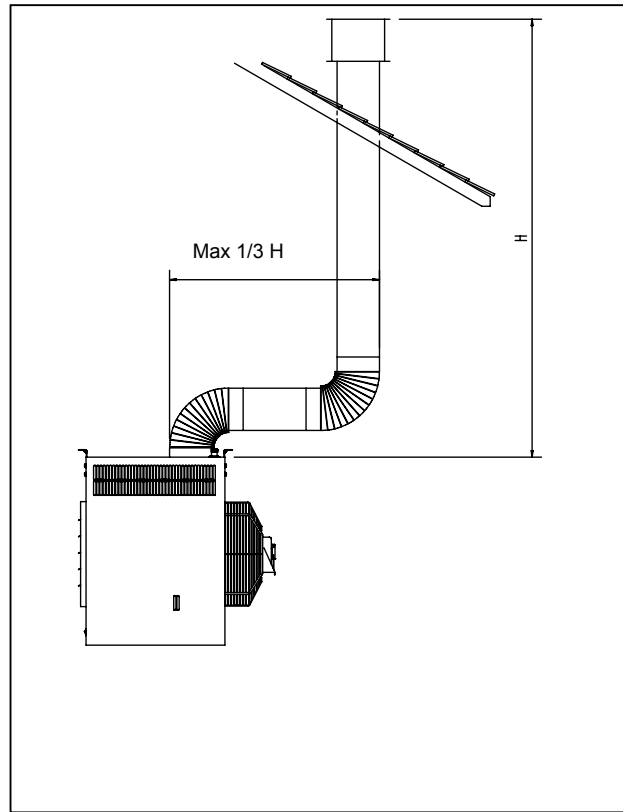

**Figure 7. COMMON FLUE SYSTEMS**

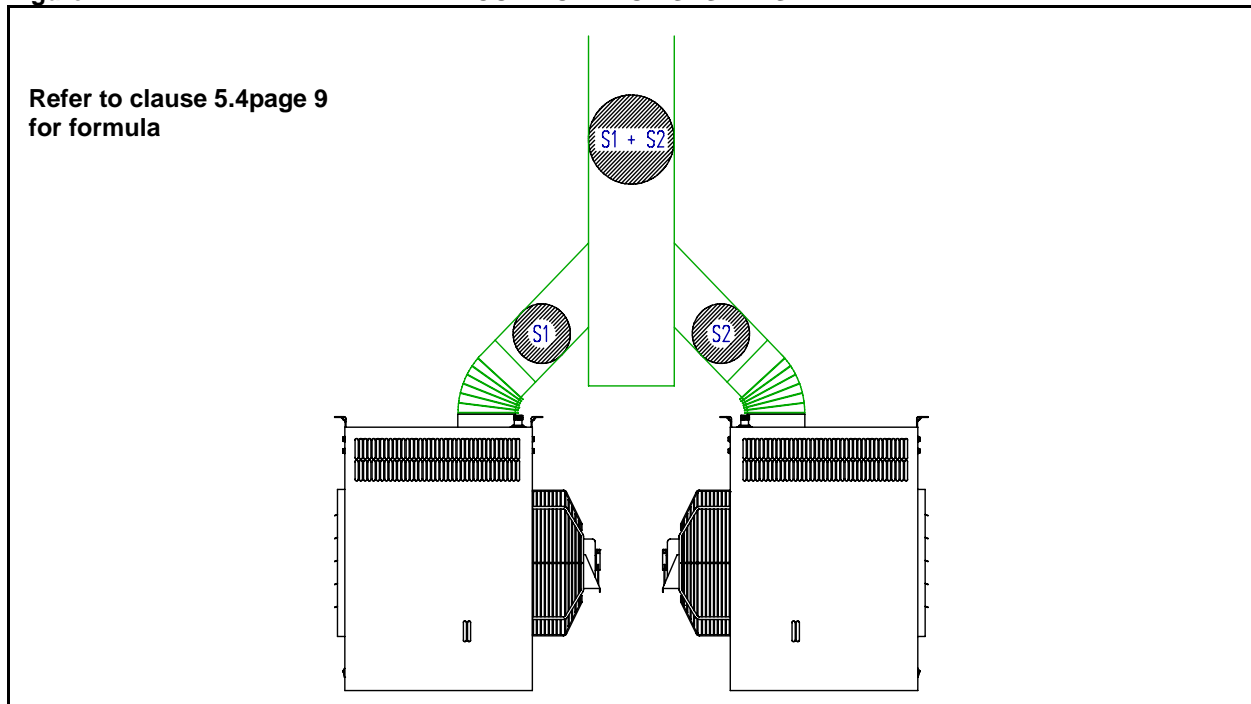

## 6. GAS CONNECTION

- 6.1 Connection to the gas service network may only be carried by suitably qualified persons. The gas installation must comply with the rules in force using materials appropriate for gas service installations.
- 6.2 Check that the gas category is in accordance with the data described on the air heater.
- 6.3 An adequate gas supply sized to provide the dynamic pressure for the total gas volume required by the air heater(s) is essential to maintain the nominal heat input.
- 6.4 A 90° action gas service tap and, to facilitate servicing, a disconnect union fitting must be provided adjacent to the appliance, see figure 8.
- 6.5 Ensure that a gas service includes a filter and has been tested and purged in accordance with prescribed practice prior to commissioning and taking the air heater into service.

Fig. 8 GAS CONNECTION DETAIL

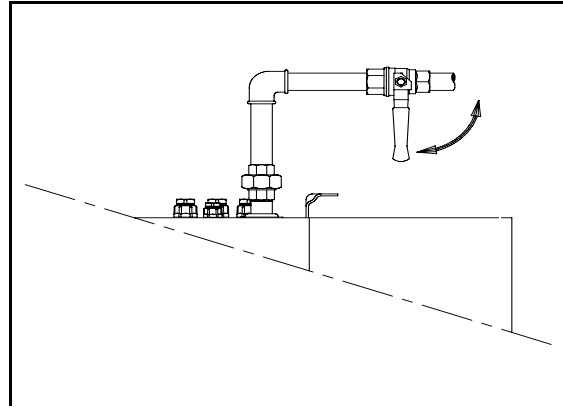

**WARNING: NEVER use a FLAME to test for GAS Soundness !!!**

## 7. ELECTRICAL CONNECTION

- 7.1 The Electrical installation may only be carried out by suitably qualified persons observing the appropriate rules in force.
- 7.2 Check that the electrical specification is in accordance with the specified data on the air heater. A unique appliance wiring diagram is supplied as a separate document attached to this one, plus an additional copy is attached to the air heater.
- 7.3 These appliances **must** be earthed.
- 7.4 A separate lockable electrical isolator for each heater must be provided adjacent to the appliance, viewable from the service access panel. The isolator must have a contact separation of at least 3.0 mm on all poles.
- 7.5 Ancillary controls are required to provide timed heat cycles, room comfort temperature level, frost protection, override air circulation etc. These are not included with the appliance and should be ordered separately.
- 7.6 Ensure when planning the external appliance control circuitry, that power will be supplied at all times to the air heater, even when it is control switched in the 'heat-off' mode. This is necessary to ensure that the fan can operate independent of the heating control. Therefore, **Never** incorporate automatic controls that electrically isolate the appliance.

**NOTE: UCE/J AIR HEATERS ARE SUPPLIED WITH EXTERNAL CONTROL CIRCUITS BRIDGED. THE AIR HEATER/S WILL OPERATE CONTINUOUSLY UNLESS THESE ARE REMOVED AND TIME AND TEMPERATURE CONTROLS SUBSTITUTED FOR THEM**

- 7.7 The centrifugal blowers fitted to UCE/J series air heaters are of the forward curved type therefore, the speed setting for the static pressure imposed by the air distribution system will govern the motor loading. All UCE/J air heaters leave the factory with the drives set to the specified operating conditions of the appliance. Table 6 provides motor characteristics for the various sizes .
- 7.8 Refer to section 8 to learn how to carry out adjustments necessary to alter the fan speed and motor load factors.

**Table 6. Maximum motor load ratings**

Motor rating	kW	0.18	0.25	0.37	0.55			0.75			1.1		1.5	
Phase	~	1	1	1	1	3	3	1	3	3	3	3	3	3
Voltage	V	230	230	230	230	230	400	230	230	400	230	400	230	400
Load rating	A	2.3	2.3	2.8	3.9	2.4	1.4	4.7	3.1	1.8	4.5	2.6	5.0	2.9

## 8. COMMISSIONING, LIGHTING AND OPERATION

### COMMISSIONING

8.1 All units are fully tested prior to despatch, however before putting the units into service the following checks should be made.

8.2 Checks required:

- earth continuity
- resistance to earth
- phase supply to correct terminals
- current rating and fuse value
- correct supply gas pressure
- correct burner gas pressure
- satisfactory & smooth ignition
- flue system is evacuating the products of combustion to outdoor atmosphere. must be made.

8.3 In addition to the above requirements checks to ensure that the fan performance and motor load factors are correct for the application and in accordance with the appliance data plate.

#### 8.4 Drives general and adjustments

8.4.1 The drive assembly of UCE/J air heaters is guard protected to class IP20. Adjustment may be necessary to set the fan duty for the static pressure and motor load requirements. It is necessary to remove the guards prior to making adjustments. Before commencing work on the fan assembly:

- Set external controls to off or their lowest setting.
- Turn **OFF** the gas supply to the air heater.
- Switch **OFF** the electricity supply to the air heater after the air circulating fan has stopped.
- Remove protection guards as necessary and carry out adjustments as appropriate.
- Before placing the appliance back into service or switching the fan on ensure that all protection guards are replaced and secured.

N.B. Rotational speed checks should be carried out using an infra red tachometer or stroboscope.

8.4.2 Adjusting the fan speed can be carried out by altering the diameter of the adjustable drive pulley.

- Loosen the belt tensioning device and remove the drive belt.

- Refer to figure 9 and note that the outer section of the drive pulley is secured by a hexagon socket grub screw to a flat on the pulley hub, this is positioned by loosening the grub screw sufficiently to enable the pulley to be either opened or closed by turning it on the thread on which it is engaged.
- It should be noted that one complete turn of the pulley half is equal to approximately 8% of the fan speed. Closing the pulley increases the speed and opening decreases the speed.
- after making speed adjustments tension belt in accordance with the dimensions given in figure 9 and check pulley alignment to ensure the belt runs correctly.

**N.B. Always ensure that the pulley is tightened onto a flat of the hub before switching on the fan, even when testing a reset condition.**

8.4.3 **Caution!**  
Opening the pulley too far will cause the belt to touch the bottom of the v groove resulting in greatly reduced belt life and loss of grip.

**Figure 9 Pulley & belt adjustment**

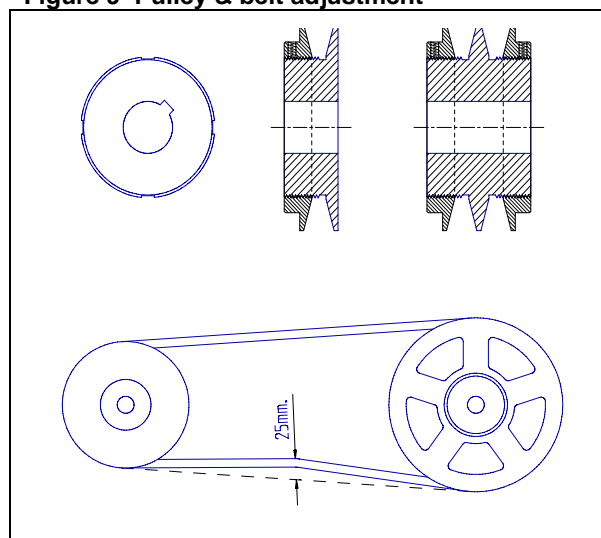

8.4.4 If the amount of adjustment is not achieved with the pulleys fitted, it will be necessary to change the driven pulley fitted on the blower and possibly the size of the drive v belt. **After adjustment ensure the motor load rating is not exceeded!**

8.5 Euroventer:  
Installations may include a Euroventer. This device is an electrically powered fan fitted into the flue system. Its inclusion will be obvious. When a Euroventer is fitted the control switching of the air heater as described in 8.10 above is via the Euroventer, which is operationally proven prior to the burner control being activated.  
NOTE: Separate instructions are provided with every Euroventer

### 8.6 LIGHTING THERMOELECTRIC

#### Models UCE/J 25 τ 45

- Ensure that the air discharge louvres are set to an open position;
- Turn **ON** the gas supply to the air heater;
- Switch **ON** the electricity supply to the air heater;
- Set room thermostat or remote control to an **OFF** setting;
- If fitted ensure that a time control is at an **ON** setting;
- Observe gas control details from figure 10 set control to star position:  
Using a lighted taper or match depress and hold the control valve start knob and apply light to the ignition burner. When the ignition burner has lit, hold control for 30 seconds. Ignition burner should remain alight when released. Turn knob to "**Flame**" position.

#### NOTE:

- If ignition burner has not lit wait five minutes and repeat the lighting procedure
- Having established the ignition burner set control to "**Flame**" position, appliance operation is now fully automatic;
- Set room thermostat to call for heat and/or adjust to the desired comfort level. The pilot burner will now light the main burner.
- In the event that the pilot flame goes out for any reason it is important to wait five minutes before attempting to re-light the gas due to the possibility of main gas flowing from the main burner if the thermocouple has been energised.
- To stop the burner, put the control knob to the **OFF** position as indicated in figure 10. It must be noted there is a security interlock which prevents re-lighting for one minute.

**Figure 10. GAS CONTROL  
TYPE UCE/J 25 τ 45**

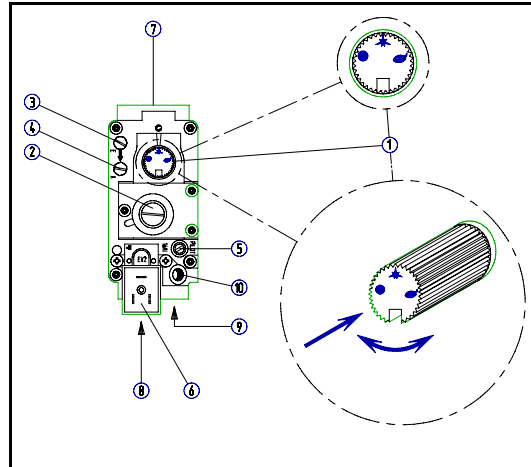

#### Legend figure 10:

- 1 Control knob
- 2 Governor
- 3 Inlet gas pressure test point
- 4 Burner pressure test point
- 5 Pilot gas throttle screw
- 6 Main burner electrical connection
- 7 Gas inlet
- 8 Gas outlet
- 9 Pilot gas line connection
- 10 Thermocouple connection

### 8.7 LIGHTING THERMOELECTRIC

#### Models: UCE/J 55 τ 95

- Ensure that the air discharge louvres are set to an open position;
- Switch **OFF** the electricity supply to the air heater;
- Turn **ON** the gas supply to the air heater;
- Set room thermostat to **OFF** or its lowest setting;
- Observe gas control details from figure 11 note start gas position;
- Using a lighted taper or match, depress the control valve start button and apply light to ignition burner. Keep start button depressed for about 20 seconds after the ignition burner has lit;
- Close burner compartment access panel/ door;
- Switch **ON** the electricity supply to the air heater;
- adjust room thermostat to desired temperature or adjust other external controls to requirements of timing and temperature.

#### Important:

If pilot flame fails to light or goes out for any reason allow 3 minutes before re-lighting. This time must also be allowed before re-ignition if there is a failure of the main burner for any reason because gas can escape from the main burner whilst the thermocouple is energised.

- 8.8 To turn off the air heater;
- a) For short periods;
    - Adjust room thermostat to lowest setting or switch **OFF** other external controls;
  - b) for extended periods;
    - Follow a) above and then;
    - Turn **OFF** gas control valve figures 10 or 11;
    - Switch **OFF** electricity supply to the air heater after the air circulation fan has stopped.

**Caution:**

The gas service tap to the air heater must not be turned off except in emergencies or for appliance servicing purposes or for prolonged periods of shut down of the air heater.

**Figure 11. GAS CONTROL  
TYPE UCE/J 55 & 95**

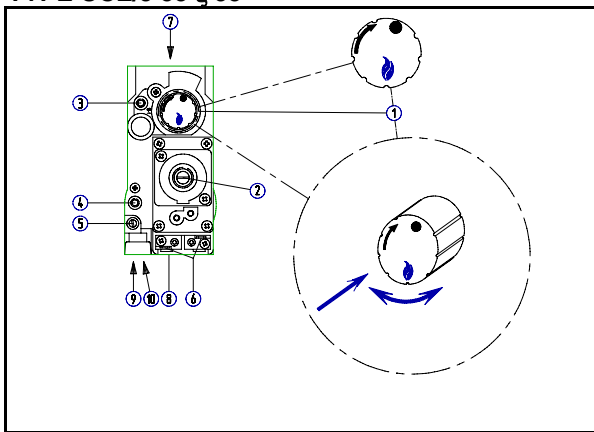

**Legend figure 11.**

1. Operating button
2. Gas governor
3. Inlet gas pressure test point
4. Outlet/burner gas pressure test point
5. Ignition burner gas throttle screw
6. Main burner electrical connection
7. Gas inlet connection
8. Gas outlet connection
9. Ignition burner gas connection
10. Thermocouple connection

**8.9 UCE/J Air heaters fitted with optional Hot Surface Ignition system.**

- 8.9.1 Ensure that the air discharge louvres are set to an open position;
- 8.9.2 Switch **ON** the electricity supply to the air heater;
- 8.9.3 Turn **ON** the gas supply to the air heater;

8.9.4 These appliances employ the direct burner ignition principle. When the external controls call for heat, a hot surface igniter will be energised and will glow for about 15 seconds, after which time the gas valve(s) will open and the burner will be lit.

8.9.5 If the burner has not lit within 5 seconds, the electronic flame relay will switch off and lockout will occur. This will cause the signal lamp to glow within the reset push-button on the appliance and/or on a remote control if fitted). After 10 seconds the reset button on the appliance or the remote control can be activated in order to reset and restart the appliance.

8.9.6 Flame failure protection is by the ionisation principle i.e. the ability of a suitable flame to pass an electrical current between the igniter and the earthed burner assembly. To check the flame current is adequate, remove jumper between terminal 17 and 18 on the automatic burner control, connect a DC micro ammeter between the terminals. Ionisation current should be  $\geq 2\mu\text{A}$ .

**Note:** The terminals carry mains voltage when energised.

**8.10 Two stage burners  
Setting and adjustment**

8.10.1 The UCJ series air heaters are equipped with two stage burners as standard specification. This feature is an option for the E version - the type of gas control fitted is the "Honeywell" VR 4601P/B or VR 4601A/B - either are fitted with a two-stage pressure governor model V4336A. Regulation is possible for the pressure range 3 - 20 mbar for natural gas and 4 - 37 mbar for propane/butane gas. The appliances are fitted with a relay to ensure that during burner start-up the initial firing rate is 100% to ensure good burner cross-lighting.

8.10.2 Setting. Refer to figure 9.

**N.B.** Allow time for pressure to stabilise before and during making adjustments.

- Lever off the plastic cover cap
- Maximum high rate setting **must** be adjusted first after which the minimum low rate setting can be adjusted. Any adjustment of the maximum setting influences the minimum setting.
- Do not adjust maximum or minimum settings above or below the pressures stated on the air heater data plate or table 6.

**To adjust:**

Connect a manometer to the appliance burner test point.

Figure 12. Two stage pressure adjustment

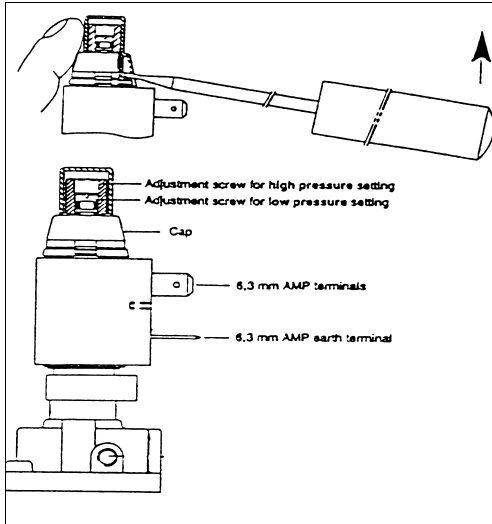

#### Adjusting maximum pressure setting

1. Energise high/low regulator, set gas control in operation and wait until an outlet pressure is recorded on pressure gauge.
2. Using an 6 mm hexagon wrench or 10mm screwdriver to turn adjustment screw for **maximum** pressure setting clockwise to increase and counter-clockwise to decrease pressure until desired maximum pressure is obtained.
3. Check maximum pressure setting several times.

#### Adjusting minimum pressure setting

1. Disconnect electrical connection of high/low regulator.
2. Set gas control in operation and wait until an outlet pressure is recorded on pressure gauge.
3. If minimum pressure setting needs adjustment then use a 3.5 mm screwdriver to turn adjustment screw for **minimum** pressure setting, clockwise to increase or counter-clockwise to decrease pressure, until desired minimum pressure setting is obtained.
4. Reconnect high/low regulator in circuit.
5. Check **maximum** pressure setting, re-adjust if necessary and check minimum pressure again
6. Replace cover cap.

## 8.11 How the UCE/J air heater works

UCE/J thermoelectric burner control air heaters operate automatically after the permanent ignition burner has been lit.

These appliances are fitted with a thermo-electric flame failure device. External controls (room thermostat - time switch) operate to provide heat on. Upon switching to on, the main burner gas valve opens and the main burner is lit from the permanent ignition burner.

Models fitted with hot surface ignition systems operate fully automatically when switched **ON** and the remote controls have been set to call for heat.

Simultaneously to being switched **ON** an electrical circuit is made to a thermal fan control switch to operate a heater within the switch.

This plus the heat of the burner causes the switch contacts close. When hot, at approximately 45°C, the air circulation fan will switch on and warm air will be discharged until the burner is switched off.

#### Note :

- The fan will run on after the burner has switched off to cool the heat exchanger.
- During periods of extreme cold operating i.e. morning start up, the fan may switch on and off for short periods due to the rapid cooling of the thermal fan switch. This will cease as the ambient temperature around the air heater rises.

In the event of overheating for any reason, thermally activated, fail safe overheat controls operate to protect the air heater. The first control LC1 switches off the burner and upon cooling will automatically reset.

**NOTE:** Two LC controls, LC1 + LC2, are fitted to UCE/J 75 & 95 if 2 fans and/or motors are used.

The second control, LC3, which switches at a higher temperature will if activated switch off the main burner and on thermoelectric models the ignition burner, thus causing controlled lock-out. Following this manual intervention is necessary to restart the air heater by relighting the ignition burner or resetting an automatic burner control after the air heater has cooled and the LC3 control has automatically reset or on automatic ignition models can be itself reset, this may take a few minutes dependent upon the ambient temperature.

- 8.12 Upon completion of the commissioning, ensure the user or a responsible person is aware of;
- How to operate air heater;
  - The need for maintenance and servicing;

**Important**

Ensure that these instructions and the user's instructions are made available for the user and/or left in a safe place, i.e. attached to the gas service meter.

**Table 7. UCE/J Models High/Low burner gas pressures and low rate consumption values**

UCE/J			25	30	35	45	55	75	95	
BURNER PRESSURE	Pressure @ 100%	Natural G 20	mbar						8.4	6.0
		Butane G 30	mbar						30.0	
		Propane G 31	mbar						35.0	
	Pressure @ 50%	Natural G 20	mbar						2.1	1.5
		Butane G 30	mbar						7.5	
		Propane G 31	mbar						8.8	
Gas consumption @ 50% <sup>1</sup> Reference 15° C, 1013 mbar	Natural G 20	m <sup>3</sup> /h	1.44	1.66	2.07	2.48	3.09	4.25	5.67	
	Butane G 30	kg/h	1.05	1.30	1.56	1.82	2.31	3.16	4.21	
	Propane G 31	kg/h	1.03	1.26	1.53	1.78	2.26	3.09	4.13	

**Note:** Burner pressures for Butane/Propane gasses are approximate based on regulated supply pressure.

- 1 Natural gas G 20 calorific value 10.48 kWh/m<sup>3</sup> @ 15° C & 1013 mbar  
 Butane gas G 30 calorific value 13.70 kg/h  
 Propane gas G 31 calorific value 14.0 kg/h

Low fire rate must not be reduced below the values stated above for 50% rating.

## 9. SERVICING INSTRUCTIONS

9.1 **CAUTION:**

Inadvertent substitution or replacement of components similar to those specified or replacement in a manner contrary to the method herein described could constitute a hazard.

**Servicing work my only be carried out by appropriately qualified persons.**

9.2 **Attention:**

Before starting to service the air heater turn **OFF** the main gas supply to the heater at the service tap provided. Switch **OFF** the main electricity supply to the heater after the air circulation fan has stopped.

- 9.3 UCE/J air heaters require maintenance and service at least once a year. More frequent servicing may be required dependent upon the environmental circumstances where the air heater(s) are installed. Advise the user of recommended service frequency after your findings during this service. Regular inspection is recommended initially, especially in dirty areas, to assess the servicing requirement frequency. Refer to the

illustrations provided figs. 18 & 19 for component and visual instruction as a guide to carrying out service work. Items that require inspection during servicing are as described below.

**FIGURE 13. BURNER ACCESS PANEL REMOVAL**

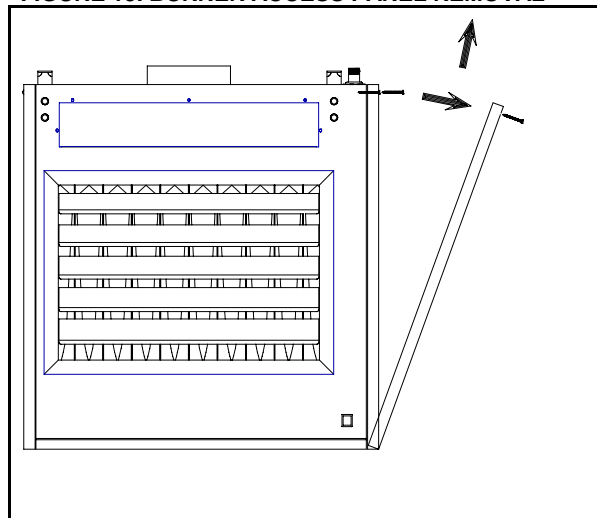

#### 9.4 **General:**

Generally clean all accessible surfaces including the outside of the heat exchanger accessible after removal of the louvre frame and fan assembly.

#### **Heater casing:**

Check for damage that could be detrimental to the correct fitting of panels and affect the correct working or noise level. Check that all assembly screws are fastened, replace missing screws. Check that all panels are fixed in place upon completion of service and that motors, fans and guards are fixed securely.

#### 9.5 **Heat exchanger:**

To be checked when carrying out burner and flue section work. Inspect heat exchanger where visible, inside by use of an inspection lamp and mirror and outside when burner, air circulation fan and louvre frame have been removed.

Look for signs of severe corrosion, splits and perforations that would indicate a failure. If upon inspection it is found that the heat exchanger is excessively dirty or blocked with e.g. soot, it will be necessary to remove the front portion of the draught diverter to aid cleaning. This can be carried out referring to fig. 15.

1. Remove the screws securing the front of the down draught diverter Key 1 and the side screws
2. The portion of the down draught diverter may then be withdrawn through the front slot by lifting and pulling outwards.
3. To replace reverse above procedure

Remove any deposits with a flexible flue brush. Remove loosened deposits with a vacuum cleaner. IF HEAT EXCHANGER IS FOUND TO BE PERFORATED ADVISE USER NOT TO OPERATE HEATER UNTIL A REPLACEMENT HAS BEEN FITTED.

#### 9.6 **Burner:**

The orifice of a gas injector is machined to precision limits, do not clean with a hard sharp object that could damage or enlarge the size. Remove burner tray carefully, see below. Check main burner rails for soundness. Clean thoroughly taking particular care to ensure that burner ports are free from lint and dust. Check gas injectors for cleanliness and that thread joints are gas tight. If necessary clean with acetone. Do not over-tighten.

#### 9.7 **Burner tray removal:**

Refer to figs. 14, 18 & 19

- 1 Disconnect gas supply at the unions below the inlet gas service tap and adjoining the gas control valve.
- 2 Disconnect the wires leading to the gas valve at the valve terminal end.
- 3 Disconnect wires leading to the thermal overhear cut off device terminals.
- 4 Unscrew qty. 2 burner tray fixing screws.
- 5 Withdraw the burner assembly by pulling from its runners until it is released.
- 6 To reassemble reverse procedure 1 thru. 5.

**FIGURE 14. BURNER ASSEMBLY REMOVAL**

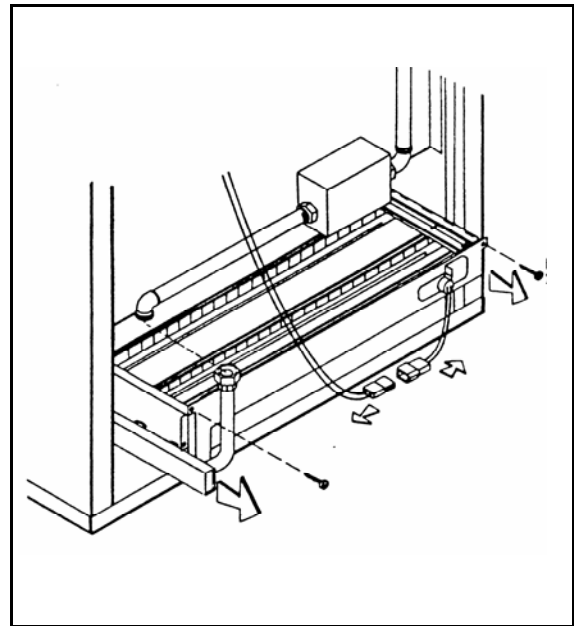

#### 9.8 **Note:**

Appliances for use on propane or butane gas have an aeration shutter fitted to the burner inlet air venturi (see fig. 20). This device may also be fitted to natural gas appliances which have been converted. The shutter is set and sealed by a multi-functional sealing plate marked LPG + NG. Ensure it is correctly reset after any burner service work is carried out.

- 9.10 To renew or service the gas valves :  
Remove burner rack assembly as described 9.7 above. To dismantle valve from manifold, take care when using spanners not to damage valve bodies which are constructed from soft die cast aluminium. It is necessary to remove the burner manifold from the burner ribbon tray assembly to unscrew the gas valve.

**FIGURE 15.  
DRAUGHT DIVERTER REMOVAL**

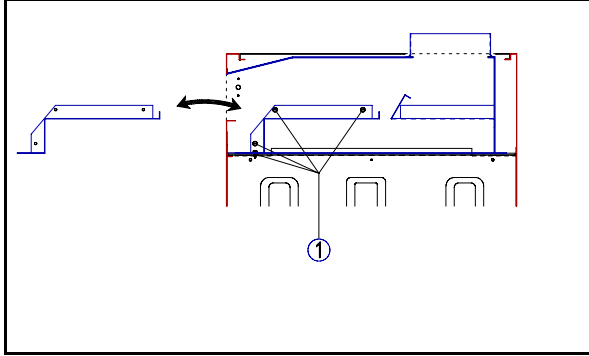

**Legend figure 15:**

1. Draught diverter securing screws left and right hand side.

**9.11 Electrical:**

Check all visible wiring for damage, check terminal security.

When removing for service or renewal any electrical component follow a logical sequence to ensure that replacement will be correct. Mark wiring to ensure that circuits are re-connected correctly.

**9.12 Flue system:**

Check that flue is in good condition adequately supported and that the flue and supports are free from corrosion and that the flue is unobstructed. Test for a positive up-draught when re-commissioning the appliance by using smoke introduced into the draught hood slot at the front of the air heater.

On flue systems fitted with a Euroventer refer to the separate instructions supplied with the Euroventer.

**9.13 Fan assembly:**

When it is necessary to remove the fan blade from the motor it should be noted that the securing screw is fitted using a thread sealing compound. local heat may be required to soften the compound so that the screw may be loosened.

- 9.14 Figure 16 shows the approximate flame pattern of the ignition burner and its relationship to the flame proving thermocouple.

NOTE: Location of the spacer rings when replacing a thermocouple. Ensure that pilot flame plays on thermocouple hot-tip only, i.e. top of thermocouple.

- 9.15 After any service work has been carried out re-commission the air heater following the steps outlined in clauses 8.2 and 8.3 of this document.

**Figure 16.  
THERMOELECTRIC IGNITION BURNER DETAILS**

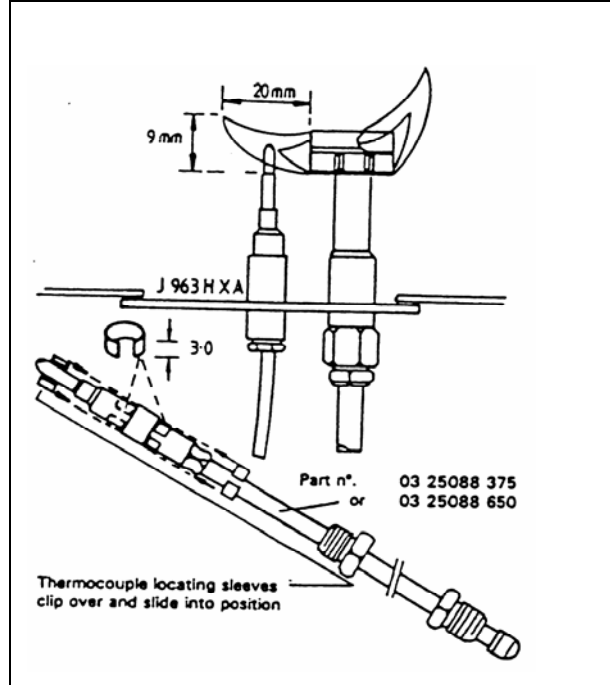

**Figure 17.  
HOT SURFACE IGNITER ASSEMBLY DETAILS**

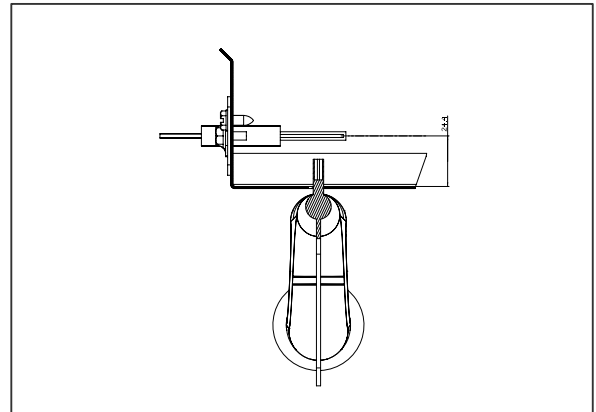

**Figure 18. COMPONENT PARTS LOCATION THERMOELECTRIC BURNER CONTROLS**

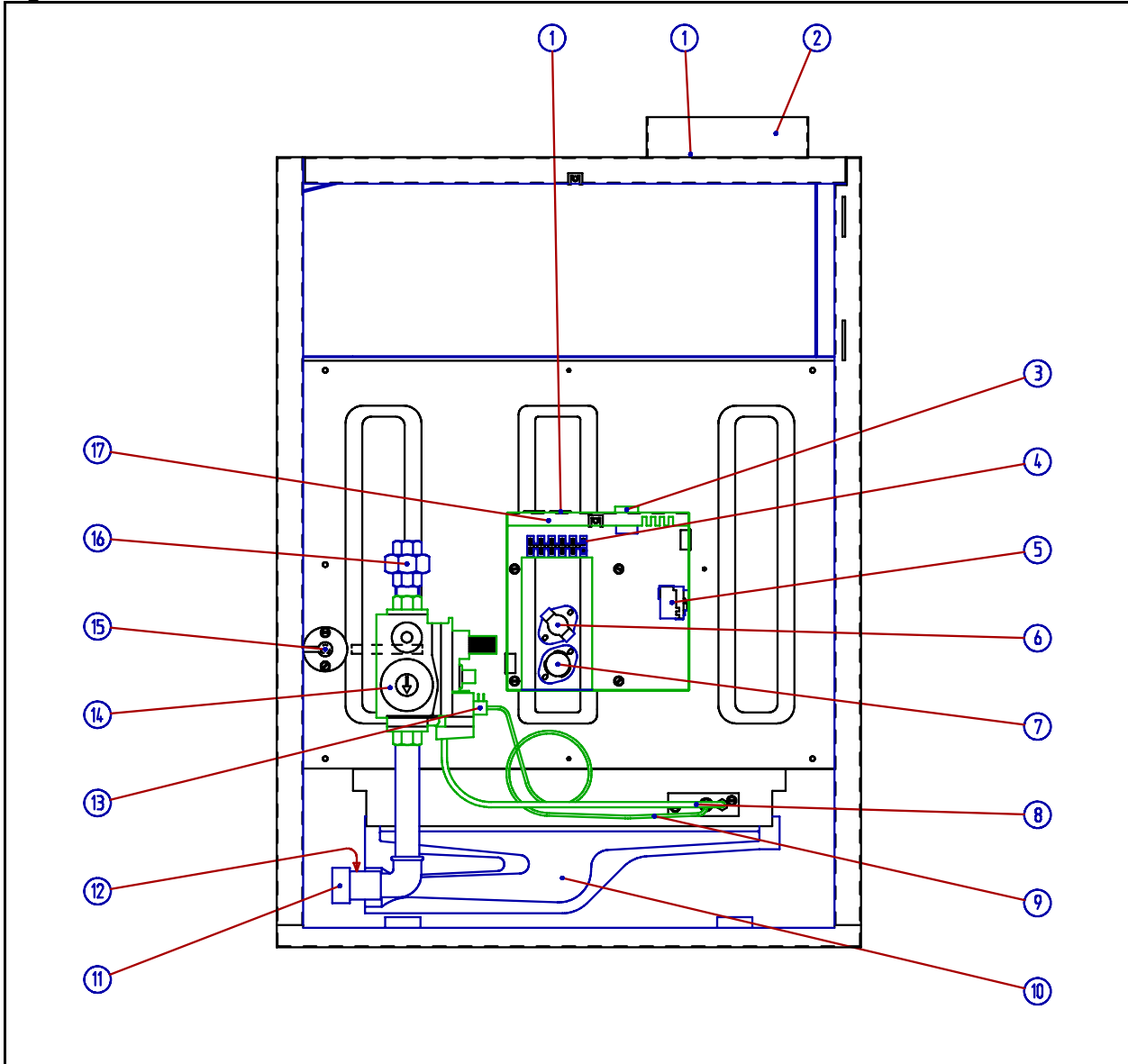

Legend figure 18:

- |   |   |
|---|---|
| 1. Electrical and Controls inlet                | 9. Thermocouple                         |
| 2. Flue socket                                  | 10. Burner ribbon                       |
| 3. Controls fuse                                | 11. Burner manifold with gas jets       |
| 4. Wiring terminals                             | 12. Burner gas pressure test point      |
| 5. Thermal overhear control LC3                 | 13. Thermocouple connection LC3         |
| 6. Limit control LC1 plus LC2 on models 75 & 95 | 14. Multi-functional gas control        |
| 7. Thermal fan control                          | 15. Thermal overhear control LC3 sensor |
| 8. Ignition burner.                             | 16. Inlet gas connection union          |
|   | 17. Main wiring box                     |

**Figure 19 COMPONENT PARTS LOCATION HOT SURFACE IGNITION BURNER CONTROLS**

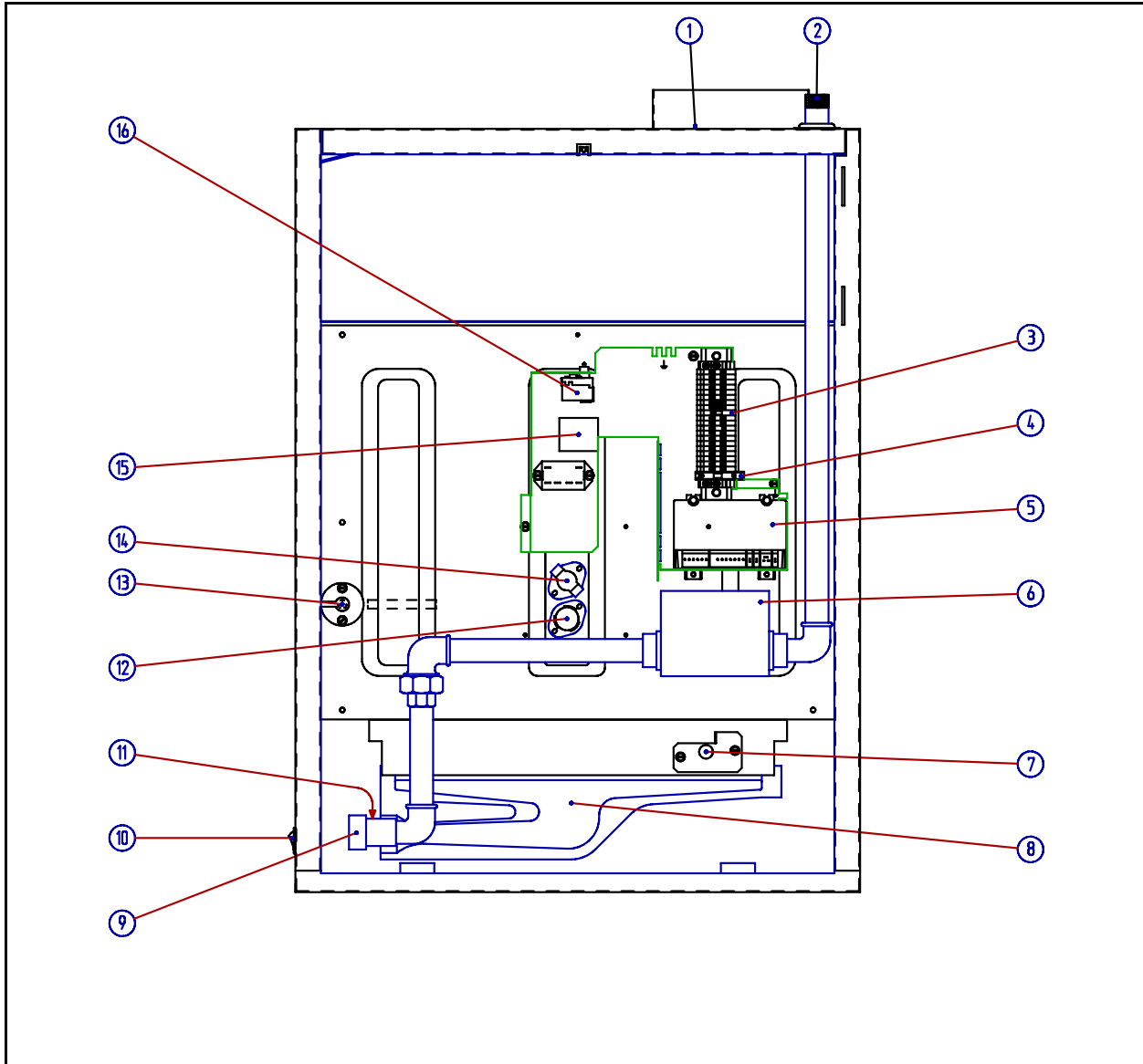

Legend figure 19

- |  |   |
|--|---|
| 1. Flue socket                         | 9. Burner manifold  |
| 2. Gas inlet connection                | 10. Burner "fail" indicator   |
| 3. Main wiring terminals               | 11. Burner gas pressure test point  |
| 4. Controls fuse                       | 12. Thermal fan control   |
| 5. Automatic electronic burner control | 13. Thermal overheat control LC3 capillary                                    |
| 6. Gas valve                           | 14. Thermal over heat (limit) control LC1 (plus LC2 on models E/J 75 & E/J95) |
| 7. Hot surface ignition                | 15. Not applicable for GB & IE  |
| 8. Burner ribbon                       | 16. Thermal overheat control LC3  |

## 10. SPARE PARTS LIST

**NOTE:** Components specific to either Thermoelectric burner control or Hot Surface Ignition are indicated thus; \* TE = Thermoelectric burner controls HS = Hot Surface Ignition systems

### 10.1 GAS SECTION

DESCRIPTION		PART NUMBER	MFGS.REF.	APPLICATION	
Gas valve	TE	03 25260	SIT 820 Nova ½"	25 τ 45	
Gas valve	TE	03 24980	H'well V 4600A :3/4"	55 τ 95	
Gas valve	HS	03 25250	SIT 830 Tandem	25 τ 45	
Gas valve	HS	03 25136	H'well VR4601AB	55 τ 95	
Gas valve	HS	03 35136	H'well VR4601PB	all 2 stage	
Ignition burner	TE	05 25164 J963HX	J 963 HXA	All	
Gas jet	Ignition burner	TE	07 25824 018	62/18	All models NG only
Gas jet	Ignition burner	TE	07 25824 010	42/10	All models LPG only
Gas jet	Main burner		07 25801 022	dia 2 mm	35 NG
Gas jet	Main burner		07 25801 024	dia 2,4 mm	25, 30 - 45 τ 95 NG
Gas jet	Main burner		07 25801 026	dia 2,6 mm	95 NG
Gas jet	Main burner		07 25801 125	dia 1,25 mm	35 LPG
Gas jet	Main burner		07 25801 130	dia 1,30	30 LPG
Gas jet	Main burner		07 25801 135	dia 1,35 mm	25, 45 τ 75 LPG
Gas jet	Main burner		07 25801 140	dia 1,40 mm	95 LPG
Thermocouple connector	TE	03 25261	SIT	25 τ 45	
Thermocouple connector	TE	03 25154 760	Honeywell	55 τ 95	
Thermocouple set	TE	35 25087	Bul. 18	All	
Olive fitting	Valve end	TE	07 25273H	M 6	ALL
Olive fitting	Burner end	TE	07 25273B	M 6	ALL
Ignition gas supply tube	TE	07 25256 500	dia 6 mm x 500 mm	ALL	

**CODES:** NG = Natural gas G20 LPG = Butane gas G30 or Propane gas G31

### 10.2 ELECTRICAL SECTION

DESCRIPTION		PART NUMBER	MFGS.REF.	APPLICATION
Thermal fan control		03 25166	TOD29T12 (250V)	ALL
Thermal over-heat control LC1 & LC2		03 24970	TOD60T11 51,5°C	ALL
Thermal over-heat control LC3	TE	03 24962	Imit 96°C 5417LS3	All TE
Thermal over-heat control LC3	HS	03 24959	Imit 96°C 5417LS1	All HS
Automatic electronic burner control	HS	03 25317	H'well S4570LS	All HS
Hot surface igniter assembly	HS	36 25217	Norton	All HS
Fuse		06 00157 125 mA	125 mA Rating	ALLI
LC3 Wire connector	TE	06 41624	-	All TE
Gas valve connector plug 230V	TE	03 24260 V1	SIT	25 τ 45
Wiring harness burner control	HS	06 41631 HGC	-	All HS
Wiring harness. Hot surface connection	HS	06 41531 HGC	-	All HS
Wiring harness. 2 stage burner control	HS	06 41621	-	All HS
Terminal rail	HS	06 41635	Entrelec	All HS
Gas valve connector plug 230V	TE	03 24980 V1	Honeywell	55 τ 95

**Note:** \* LC2 applies only to models 75 and 95 where two fans and motors are used

### 10.3 AIR HANDLING SECTION

DESCRIPTION	PART NUMBER	MFGS. REF.	APPLICATION
Centrifugal blower	02 25751 01	BDC 241-241	25
Centrifugal blower	02 25752 01	BDC 270-270	30
Centrifugal blower	02 25752 01	BDC 321-321	35 τ 55
Centrifugal blower	02 25754 01	BPC 270-270	75
Centrifugal blower	02 25756 01	BPC 321-321	95
Fan motors	Specify: kW rating - 1 or 3 phase & shaft size when ordering		

## 11. GAS CONVERSION

11.1 UCE/J air heaters are designed to operate on natural, propane or butane gas and will be supplied fitted for the gas type ordered.

In the event of site conversion to a different gas type it is necessary to convert the gas burner and burner controls.

To carry out the conversion refer to section 9 of this document which explains how to remove and replace the burner assembly.

11.2 The following changes must be made:

- Change the main burner jets to the size as given in 10.1;
- Change the ignition burner jet as given in 10.1;

c. Set burner primary air shutter as appropriate referring to figure 20;

e. Adjust gas governor;  
Natural gas to setting pressure as per data plate supplied;  
LPG gases to maximum pressure setting adjuster screwed in to stop. Seal governor after setting.

For LPG gases a governor blank off plate may be used, remove governor and fix plate;

f. Affix new data plate and gas type over-sticker

11.3 Upon completion of conversion re-commission the air heater in accordance with section 8 of this document.

Figure 20.

GAS CONVERSION DATA

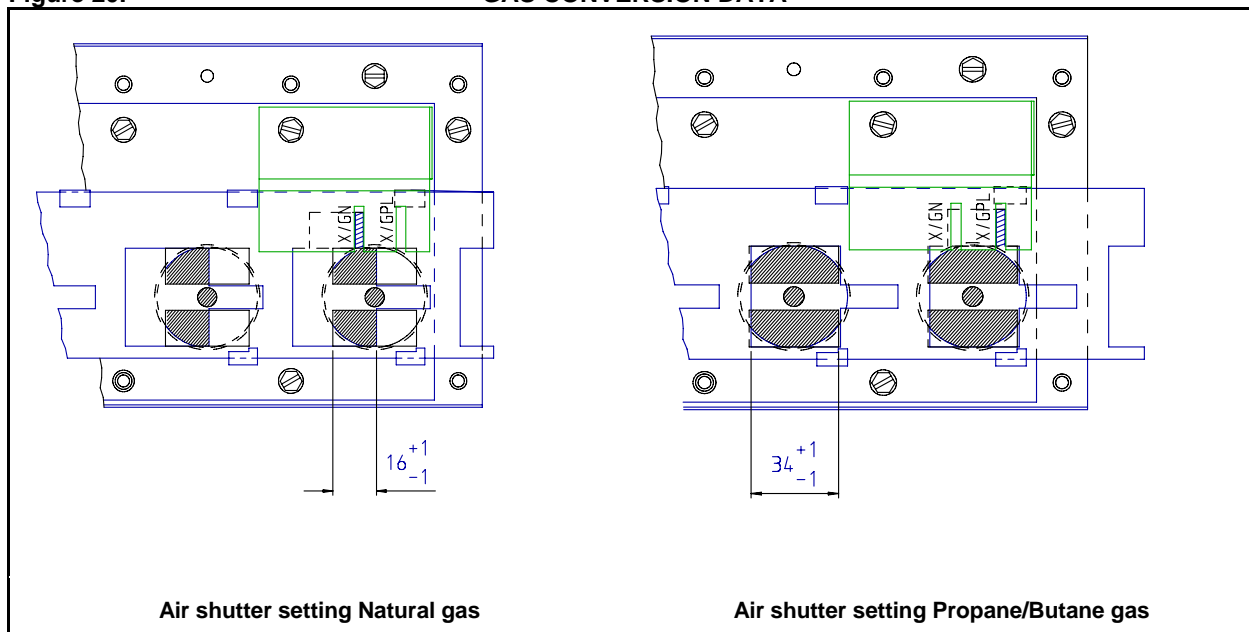

Air shutter setting Natural gas

Air shutter setting Propane/Butane gas

## 12. FAULT FINDING

### THERMOELECTRIC BURNER CONTROL MODELS

#### 12.1 Ignition burner will not light :

- Read lighting instructions;
- Check gas supply is turned on;
- Air in gas supply : check purging;
- Excessive high/low gas pressure : adjust throttle screw figs. 10 & 11;
- Blocked ignition burner injector orifice
- Faulty gas valve : renew;

#### 12.2 Ignition burner lights but will not establish

- Loose connection on thermocouple or re-route leads : check security;
- Ignition burner flame too small : adjust;
- Ignition burner jet dirty : clean;
- Thermal overheat (limit) control LC3 loose connection on control terminals: check renew connection as necessary, loose connection on gas valve;
- Faulty thermocouple : renew;
- Faulty gas valve : renew;
- Faulty overheat (limit) control LC1,LC2 or LC3: renew;

#### 12.3 Ignition burner lights and established but main burner will not light :

- Check electricity supply switched ON;
- Check room thermostat is calling for heat : adjust;
- Check time switch if fitted is in ON mode;
- Open circuit to gas valve : check wiring;
- Faulty gas valve : renew;
- Faulty or loose connection on thermocouple/LC3: check
- If appliance is fitted with a Euroventer : check it is operating.

#### 12.4 Main burner lights and goes out after short period :

- Insufficient combustion air : open door or window to check air supply;
- Euroventer air flow proving operating when flue gas is hot : check flue and Euroventer air proving system;
- Room thermostat in warm air flow : check temperature around thermostat;
- Room thermostat on vibrating surface : check contacts chattering near set points;
- Fan rotating slowly, heater operating on thermal limit control LC1/LC2 : check fan motor, suspect capacitor fault;
- Fan guard blocked with dust to reduce air flow : clean;
- Discharge louvres closed : open;
- Ambient air temperature too high, set point reached.

### HOT SURFACE IGNITION CONTROL MODELS

#### 12.5 Burner does not light:

- Thermostat set too low;
- Controls fuse has blown;
- If fitted Euroventer not operating;
- Burner relay in lock-out or faulty;
- Faulty thermal over heat (limit) control;
- Thermal over heat control LC3 in lock-out mode;
- Faulty hot surface igniter;
- Insufficient ionisation flame current : should be > 2 $\mu$ A;
- Incorrect wiring or bad earth connection.

#### 12.6 Cool air is discharged continuously at start up or during operation when burner is off? :

- Room thermostat on : set to off;
- Ignition burner is unlit : light up;
- Thermal fan switch faulty : renew switch;
- If fitted manual override fan switch in ON mode : switch OFF;

#### 12.7 Air circulation fan will not run :

- Open circuit : check;
- Thermal fan control switch faulty : renew;
- Defective fan motor capacitor : renew;
- Defective motor : renew;

#### 12.8 Air circulation fan runs and stops while burner remains alight :

- Thermal fan switch heat element broken : renew switch;
- Low ambient temperature : wait, it will correct as temperature rises;
- Motor thermal overload switch operating : check motor current rating - renew motor if faulty;
- Thermal fan control heater element wiring incorrect : check, correct if necessary;
- Faulty thermal fan control : renew;

## 13. HEALTH AND SAFETY STATEMENT

### Health and Safety Information for the Installer and Commissioning-Service Engineer

Under the Consumer Protection Act 1987 and Section 6 of the Health and Safety at Work Act 1974 we hereby provide the following information on substances hazardous to health. **Product range reference: "UCE/J"**

13.1 During first firing some smoking may occur, this is due to the burning off of protective/lubricating oils used during appliance production. Most of this will have been removed during the production testing process. It is a wise precaution to ensure that adequate ventilation is provided during the initial firing and throughout the commissioning period, this is particularly important if the discharge air is to blow into a confined space. This smoking does not constitute a poison hazard.

13.2 The products contain no asbestos; copper is not employed in gas carrying components; solder which has a melting point below 450°C is not used; paints for corrosion protection and decoration are heat cured and contain no lead.

13.3 The above appliances meet the Electrical Safety requirements of EN60 335 Pt 1 1988.

13.4 Small quantities of adhesives and sealants used in the product are dried and cured and present no known hazard.

#### 13.5 **Insulation and Seals.**

Material: Synthetic Ceramic Fibre with Organic binder.

Description: Tapes and Papers

Known hazards: Some people can suffer reddening and itching of the skin. Fibre entry into the eyes will cause foreign body irritation.

Inhalation will cause irritation to the respiratory tract. As with any dust pre-existing respiratory condition and lung diseases may be aggravated.

Prolonged exposure for the purposes envisaged pertaining to this product is not anticipated.

Precautions: Wear protective gloves when handling. If abrading and dust is generated suitable protective respirators must be used.

People with a history of skin complaints may be susceptible to irritation.

Dust levels are only likely when the material is abraded.

In general normal handling and use for this purpose will not present discomfort. Follow good hygiene practices, wash hands before consuming food or using the toilet.

First Aid: Medical attention must be sought following eye contact or prolonged reddening of the skin.

#### 13.6 **Thermostat.**

Material: Illuminating Kerosene.

Description: Sealed phial contains a small quantity in liquid form.

Recognition: Colourless liquid, paraffin oil/petroleum hydrocarbon odour.

Characteristics: Non-corrosive, flammable with no poisonous reference - CH poison Class 3

Precautions: Avoid handling. This product can irritate and defat the skin. Prolonged contact may cause dermatitis. Avoid breathing vapour. Avoid eye contact. Do not ingest.

First Aid: Skin. Wash thoroughly with soap and water.

Eyes. Rinse immediately with copious amounts of clean water.

Ingestion: Seek medical advice.

**NOTE:** If skin irritation persists seek medical advice.

#### 13.7 **Electrolytic Capacitor**

Two types are used by random selection:

Recognition: 1. Plastic enclosure 2. Aluminium enclosure

Material: Contained liquid electrolyte

Known hazards: Electric shock possible if charged.

Precautions: Discharge to ground/earth. Do not incinerate.

First Aid: Treat for electric shock if affected.

## 14. USER INSTRUCTIONS

**NOTE:** Keep a copy of this document near your air heater !

**WARNING:** This appliance must be earthed.

- 14.1 Your UCE/J air heater should have been installed, commissioned and tested in accordance with these the manufacturer's written recommendations.
- 14.2 In the interest of safety and user satisfaction it is important that this document is read and understood. If in any doubt, consult your installer or your local gas region supplier.
- 14.3 It is in your interest to ensure proper service and maintenance is carried out on a regular basis by a competent service undertaking. We suggests at least once every year.
- 14.4 In the event of difficulties in resolving any of these matters, please do not hesitate to contact the manufacturer or their official distributor.

### 14.5 About your air heater :

- UCE/J air heaters are state of the art gas fired appliances and incorporate an atmospheric burner which uses air for combustion taken from the location in which the air heater is installed. Products of combustion are vented to outdoor atmosphere via a permanently connected natural draught flue. The flue system may incorporate a fan to assist evacuation of the flue gasses.
- The location of the air heater should be maintained at normal ambient pressure. Changes to the building after air heater installation should have regard to the heating installation, i.e. creation of draughts from doors, windows. Other air handlers and installation of air extraction equipment may cause equipment may cause negative pressure environments, which can, seriously affect the operation of this type of air heater.
- The space heating process using UCE/J air heaters is for air to be circulated through the appliance whereby it gains heat from a heat exchanger which is discharged into the space to be heated. Dependant upon the installation configuration i.e. ducted return air or the air may be recirculated through the appliance thus an unobstructed path for the return air must be maintained. This is particularly important.

### 14.6 How the air heater works :

Gas is burned by an atmospheric burner which fires into a multiplex combined combustion/heat exchanger. The gas burner is controlled by a gas valve which is switched via external controls i.e. a room thermostat and time switch.

UCE/J air heaters are available with a choice of burner ignition systems;

Thermoelectric: Incorporate a permanent pilot flame on a separate ignition burner which requires manual lighting as described below, or;

Automatic Hot Surface Ignition System: Which operates fully automatically at the dictates of the external time and temperature controls.

Air heaters with a permanent flame ignition are protected by a thermo-electric flame failure device. Once the ignition burner has been lit and established the heater operation is automatic following the dictates of the external timing and/or temperature controls.

Air heaters with hot surface ignition are protected against flame failure by the igniter acting as a sensor in the burner flame. When the external controls signal a call for heat the igniter becomes energised and after a short time it glows, when sufficient heat to light the gas has been generated, then the gas valve/s open and the burner lights.

Safety against overheating is assured by the inclusion in the controls circuit of two thermal overheat controls. There is an automatic recycle control which protects against low air flows i.e. clogged air ways, fan failure ! The second control being a super overheat control which operates to switch off the ignition burner in the event of gross overheating for any reason. Two types of this control are employed for this function to suit availability, they can be identified by looking into the controls compartment of the air heater and comparing with figures 18 or 19. Manual intervention to relight the ignition burner is necessary for thermoelectric appliances, manual intervention to reset the electronic burner control either on the appliance or a remote control device is necessary on those fitted with hot surface ignition systems.

When the main burner fires and warms the heat exchanger, the heat is sensed by a thermally actuated fan control which switches on the fan when the temperature has reached approximately 45°C. At the end of a heating cycle when the burner is switched off, the air circulation fan will continue to run on until the air heater has cooled to a safe condition. Thereafter the fan will remain off until the next cycle is initiated.

#### 14.7 To light the air heater:

##### Thermoelectric;

##### Models UCE/J

25 τ 45 see fig. 22

- Carry out the following procedure (which is also displayed on the air heater casing)
- Ensure that the air discharge louvres are set to an open position;
- Turn **ON** the gas supply to the air heater;
- Switch **ON** the electricity supply to the air heater;
- Set room thermostat or remote control to an **OFF** setting;
- If fitted ensure that a time control is at an **ON** setting;
- Observe gas control details from figure 22 set control to star position:  
Using a lighted taper or match depress and hold the control valve start knob and apply light to the ignition burner. When the ignition burner has lit, hold control for 30 seconds. Ignition burner should remain alight when released. Turn knob to "**Flame**" position

##### NOTE:

- If ignition burner has not lit wait five minutes and repeat the lighting procedure
- Having established the ignition burner set control to "**Flame**" position, appliance operation is now fully automatic;
- Set room thermostat to call for heat and/or adjust to the desired comfort level. The pilot burner will now light the main burner.
- In the event that the pilot flame goes out for any reason it is important to wait five minutes before attempting to relight the gas due to the possibility of main gas flowing from the main burner if the thermocouple has been energised.
- To stop the burner, put the control knob to the **OFF** position as indicated in figure 22. It must be noted there is a security interlock which prevents relighting for one minute.

#### 14.8 To light the air heater:

##### Thermoelectric burner control

##### Models UCE/J

55 τ 95 see fig. 23

- Carry out the following procedure (which is also displayed on the air heater casing)
  - a Switch OFF electricity supply to the air heater;
  - b Ensure that the gas supply to the air heater is on;
  - c Set room thermostat to OFF or its lowest setting. If fitted, ensure time switch is set to an ON cycle;
  - d Depress and hold control valve start button fig. 23;
  - e Using a lighted taper or match light the ignition burner located as shown;
  - f Keep start button depressed 20 seconds after ignition burner has lit;
  - g Close burner compartment access door;
  - h Switch ON electricity supply to the air heater;
  - i Adjust room thermostat to desired temperature and any other external controls to on;

##### Important :

If ignition burner pilot flame fails to light or goes out for any reason allow 3 minutes before re-lighting. This time must also be allowed before a re-ignition attempt if there is a flame failure of the main burner for any reason.

To turn off the air heater for short periods

- a Adjust room thermostat to lowest setting or switch to off other external controls; To turn off for prolonged periods, carry out 'a' above then;
- b Turn off gas control valve fig 23;
- c Switch off main electricity supply after air circulation fan has stopped;

To turn off for prolonged periods, follow procedure outlined above & then turn off the gas inlet service tap.

##### To light the air heater:

##### Hot surface ignition systems;

1. Turn on the gas supply to the air heater;
2. Switch on the electricity supply to the air heater;
3. Ensure that time switch (if fitted) is set to an **ON** cycle;
4. Adjust room comfort control/ thermostat to desired temperature;
5. Air heater will now light automatically when the room thermostat calls for heat.

6. If the appliance does not light:
  - a) check the automatic burner control does not require resetting. An indicator light will glow on the front panel of the appliance or on a remote control where applicable. Reset by press the light button on the appliance or remote control.
  - b) check if the thermal over heat control requires resetting see figure 19 page 20 key 10;

If the thermal overheat control requires resetting and doing so restarts the air heater, wait until the appliance warms up to thermal equilibrium, to ensure that the over heat control does not operate again. **If it does and the temperature surrounding the air heater is less than 30°C then switch OFF the appliance and call for service.** If the temperature surrounding the appliance exceeds 30 °C, take appropriate action to reduce the temperature in the vicinity of the appliance.

**Warning:**

The externally fitted gas service tap must not be operated except in emergencies or for servicing or prolonged periods of shutdown of the air heater.

**Figure 22. LIGHTING THERMOELECTRIC MODELS  
25 τ 45**

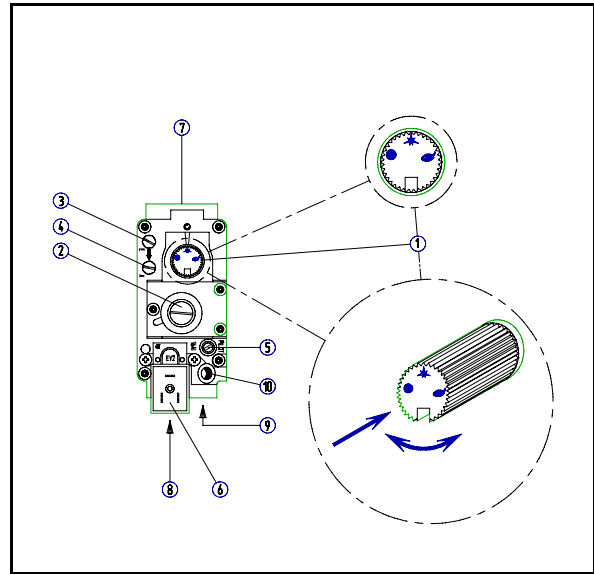

**Figure 21 USER LIGHTING ACCESS PANEL**

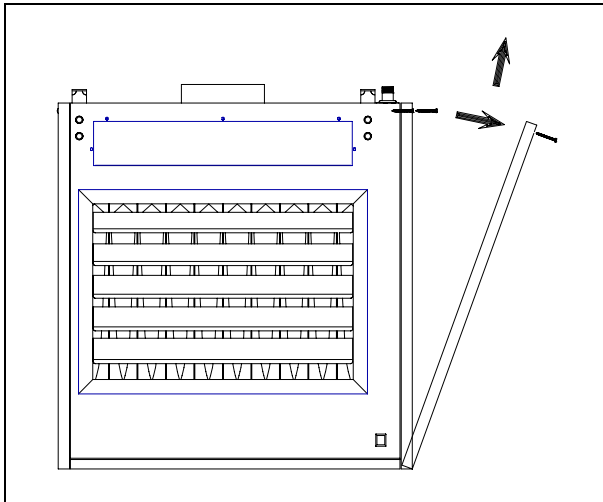

**Figure 23. LIGHTING THERMOELECTRIC MODELS  
55 τ 95**

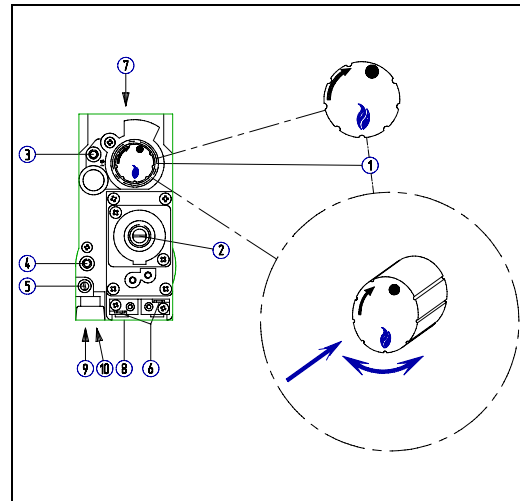

#### 14.9 **Air circulation:**

Some AmbiRad unit air heaters have fans connected to a remote override switch. This enables cool air to be used for circulation purposes when the air heater is not used for heating purposes e.g. in summer months.

- a. Switch ON mains electricity supply to the air heater;
- b. Switch ON the manual override switch on remote control panel;

#### 14.10 **Important:**

In the event that the thermal overheat (limit) control LC3 has operated requiring relighting the air heater, wait close by the air heater for 15 minutes after re-lighting to ensure normal operation.

If the overheat control locks out again, turn **OFF** the air heater and call for service to establish the reason and rectify the fault.

#### 14.11 **Euroventer:**

Installations may include a Euroventer. This device is an electrically powered fan fitted into the flue system. Its inclusion will be obvious when a Euroventer is fitted the control switching of the air heater as described in 15.6 above is via the Euroventer, which is operationally proven prior to the burner control being activated.

#### 14.12 **Maintenance & servicing:**

Maintenance and service must only be carried out by competent persons. Periods between service are dependent upon the local environment where the air heater is installed. Regular inspection is recommended initially to ascertain routine service intervals. Where local environmental circumstance change e.g. different processes being carried out in a factory, the service interval should be reconsidered. Ask your installer, service undertaking or the manufacturer about inspection and service intervals.

The service engineer is asked in section 9 of this document to advise the user of his recommended frequency for servicing after carrying out the first service.

The air heater should be serviced at least once every heating season. Ensure that any combustion air vents fitted to the building in which the air heater is installed are unblocked. Periodically check to ensure that the outer casing of the air heater is clean, excessive dust might constitute a hazard.

END OF USER INSTRUCTIONS

# **AmbiRad UCE/J**

**ONE OF A GENERATION OF CE MARKED GAS FIRED ENERGY  
EFFICIENT AIR HEATERS**

**BEST USED WITH AmbiRad OPTIONAL ELECTRONIC CONTROL PANELS  
SAVE ENERGY AND OPTIMISE THERMAL COMFORT**