

# AMBIRAD

ENERGY EFFICIENT HEATING SYSTEMS



## EnviroAir

Gas fired  
air heaters



## Introduction

*Ambi-Rad STB, STE, UCB and UCE EnviroAir gas fired air heaters are compact, fully automatic and suitable for a wide range of industrial and commercial applications.*

*They are primarily designed for ducted applications to provide heating and ventilation. However they may also be used for free blowing applications where either higher airflows or fresh air is required. Units may either be installed in plant rooms or suspended in the area to be heated thereby saving valuable floor space.*

*Designed and manufactured to the highest degree of technical excellence, the heaters have an established record of reliability, long life and low maintenance. For free blowing applications a range of optional outlet louvres provide a choice of air distribution. Discharge nozzles for increased mounting heights are also available.*

*UCB and UCE units are conventional open flued appliances, drawing their combustion air from inside the building.*

*The STB and STE units are room sealed fan assisted balanced flue appliances with a separated combustion system. Separated combustion technology provides mechanically induced outside air for combustion, preventing dirt, dust or other contaminants from entering the burners or combustion process. The room sealed units also provide significant improvements in thermal and seasonal efficiency thereby reducing running costs compared to conventional open flued models.*

*The STB and STE units have a thermal efficiency of over 91% and significantly reduced carbon emissions. They are included on the Government's Energy Technology List and are eligible for Enhanced Capital Allowances.*

## EnviroAir benefits

- Simple low cost heating and ventilation.
- Versatility: wide range of airflows and static pressures up to 400 pascals.

## Comprehensive range

- Choice of heat outputs from 24kW to 95kW and airflows from 1350m<sup>3</sup>/h to 12000m<sup>3</sup>/h.
- Wide range of optional filters, dampers and burner control systems make the units very versatile, thereby enabling the precise match of both the heating and ventilation requirements for a wide range of applications.
- Standard units are suitable for operation on natural gas. Propane units are available as an option.



This symbol verifies that the product was independently assessed and qualifies for the ECA scheme, an upfront tax relief enabling businesses that invest in energy-saving equipment to claim 100% first-year capital allowances against their taxable profits.

\* Applies to STB & STE units only.



## Features

### Optional burner controls

Two stage High/Low burner control provides closer temperature control and improved air circulation resulting in significantly reduced heat stratification in the building.

Modulating burner control provides proportional control between high and low fire for even closer control and is particularly beneficial where heated fresh air is required.

### Centrifugal fan

Units are fitted with a belt driven double inlet forward curved centrifugal fan, suitable for operation up to a maximum of 400 pascals static pressure. Different sizes of motors may be selected to suit both the airflow and pressure requirements of the installation.

For applications where ducted return air or fresh air is not required the STB and UCB models with an exposed fan may be used.

### Fan cabinet

STE and UCE models are supplied complete with a fan enclosure cabinet. The fan cabinet allows the use of return air ducts, filters and fresh air intakes. Full size access doors are fitted to fan cabinets for ease of service access and all the gas and electrical control, filter and motor access is from one side. Open back cabinets are fitted with an air inlet protection grille (not shown).



### Mixing box

STE and UCE units may also be fitted with a mixing box type cabinet complete with either a single damper or interlinked fresh air and return air dampers. Interlinked dampers may be fitted to the top and rear of the cabinet or bottom and rear to suit ductwork layouts. Dampers may also be fitted top and bottom however this configuration requires two separate damper actuators.

Dampers may be either manually controlled or fitted with two position or fully modulating damper actuators.

Optional filters fitted internally within the cabinet provide filtration to both the fresh air and return air.



### Installation

Units may be suspended or base mounted on a non combustible surface, STE and UCE models are supplied on a galvanised steel base frame.

Units installed as room sealed models must use balanced flue terminals supplied by Ambi-Rad to comply with CE certification. Balanced flue outlets are available as either roof outlets or to avoid roof penetrations the units may be flued through the wall using a wall outlet. The balanced flue terminals are ordered separately from the heater and extension pipes are available to extend by up to 9 metres the distance from the terminal to the heater (reduce by 1.5m for each 90° bend).

Units must not be installed in areas classified as hazardous where there are highly flammable or explosive vapours or dusts. Where halogenated hydrocarbon or chlorinated vapours are present, units with AISI 316 grade heat exchangers should be specified.

Units should be installed in accordance with BS 6230 and any local codes, paying particular attention to the requirements for combustion air.

Controls wiring must be installed in accordance with the wiring diagrams provided and must not interrupt the mains supply to the heater.

Installation must be carried out by a suitably qualified installer in accordance with the installation instructions provided and current codes of practice. Incorrect installation will invalidate warranty.



## Specification STB and STE units

### Cabinets

All components exposed to the products of combustion are manufactured from aluminised steel and exterior panels have a powder coat finish. Flue and combustion air spigots are located on the top of the unit to accept balanced flue connections. Balanced flue terminals may be extended using matching sealed pipework, up to 9 metres of flue and 9 metres of combustion air pipe may be added (deduct 1.5m for each 90° bend).

Where height is restricted the heaters can be ordered as non standard with the flue and combustion air spigots on the side of the heater (same side as burner access), this should be clearly stated on the heater order.

For applications where the units are to be used as fan assisted flue heaters with combustion air being drawn from the space an inlet guard should be fitted to the combustion air inlet.

STE models are supplied complete with a galvanised steel base frame to allow either four point suspension or floor mounting in a plant room. Optional EU2 or EU4 filters can be fitted inside the fan cabinet and provide filtration to both the fresh air and return air. Other grades of filtration are available on request.

Depending on the application requirements the fan cabinet can be supplied with either a single skin construction or fully insulated.

### Heat exchanger

The heat exchanger is manufactured from special grade aluminised steel. For applications using fresh air optional stainless steel (AISI 409) heat exchangers are recommended. For areas where chlorinated vapours may be present corrosion resistant stainless steel (AISI 316) heat exchangers should be specified.

### Burners

Burners are mounted in a slide out tray. The burner tray may slide out from either the left or right side of the heater (when facing the air discharge) and this must be clearly stated on the heater order.

### Gas and safety controls

A multi function gas control valve and a fully automatic electronic ignition system provide full safety monitoring of the heater operation. Fan operation is controlled by an integral fan control, this delays fan start up until the heat exchanger has reached operating temperature. In addition it continues to operate the fan after the burners have shut down, until all useful heat has been dissipated into the building. For heating and ventilation applications an optional constant fan relay can be fitted to provide constant fan operation controlled via a time switch.

A differential pressure switch monitors the operation of the integral power flue venter, so that in the event of either the flue or combustion air being restricted the heater will shut down.

Limit switch thermostats are fitted to monitor the operation of the heater and switch off the burner in the event of overheating, for additional safety an extra high limit thermostat is fitted on all EnviroAir units.

### Air handling

STB and STE units are provided as standard with a duct spigot outlet for connection to ductwork. For free blowing applications louvres and discharge nozzles are available as options and are ordered separately.

Units are suitable for a wide range of airflows and static pressures up to 400 pascals. A range of different size motors can be fitted in each unit to match the precise duty requirements.

## Technical data

### STB and STE models

Model		100	125	150	175	225	300	400
Nominal heat output	kW	24	29	35	41	52	71	95
Gas rate								
Natural gas G20	m <sup>3</sup> /h	2.75	3.36	4.07	4.76	6.03	8.25	11.01
Propane G31	kg/h	2.06	2.51	3.04	3.56	4.51	6.17	8.24
Gas connection†	BSP in	¾	¾	¾	¾	¾	¾	¾
Flue diameter	mm	100	100	100	130	130	130	130
Combustion air inlet	mm	100	100	100	130	130	130	130
Airflow @ 125Pa (standard motor)	m <sup>3</sup> /h	1800	2600	3050	3400	4200	5900	7000
Minimum airflow	m <sup>3</sup> /h	1350	1650	2000	2300	2900	4000	5000
Standard motor (230V single phase)	kW	0.18	0.37	0.37	0.37	0.55	0.75	0.75
Maximum motor size (three phase)	kW	1.1	1.1	1.5	1.5	2.2	3.0	3.0
Maximum airflow (with larger motor)	m <sup>3</sup> /h	3000	4000	5000	5000	7200	9000	12000
Approximate weight (STB models only)*	kg	108	135	155	155	168	193	248
Approximate weight (STE models only)*	kg	155	188	219	219	241	295	350

† The connection size on the heater does not indicate the size of gas supply pipework, gas pipework should be sized within allowable pressure drops to comply with current codes of practice. Natural gas G20 calorific value 10.5 kWh m<sup>3</sup> GCV minimum inlet pressure 17.5 mbar, maximum inlet pressure 50 mbar.

Propane G31 calorific value 14.0 kWh m<sup>3</sup> GCV minimum inlet pressure 37 mbar, maximum inlet pressure 50 mbar.

\* Actual weight depends on options fitted.

# Dimensions

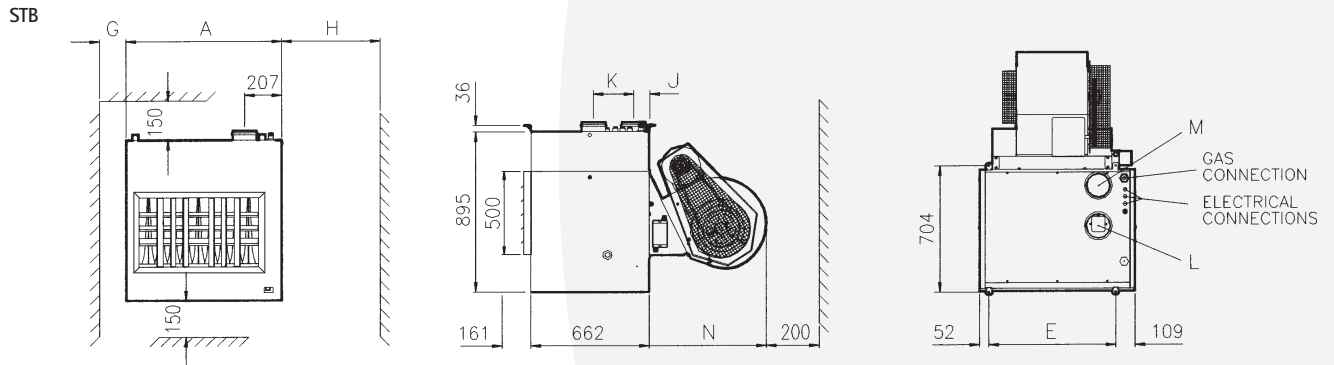

Note: STB shown with louvres (optional extra). For duct outlet dimensions see STE drawing below.

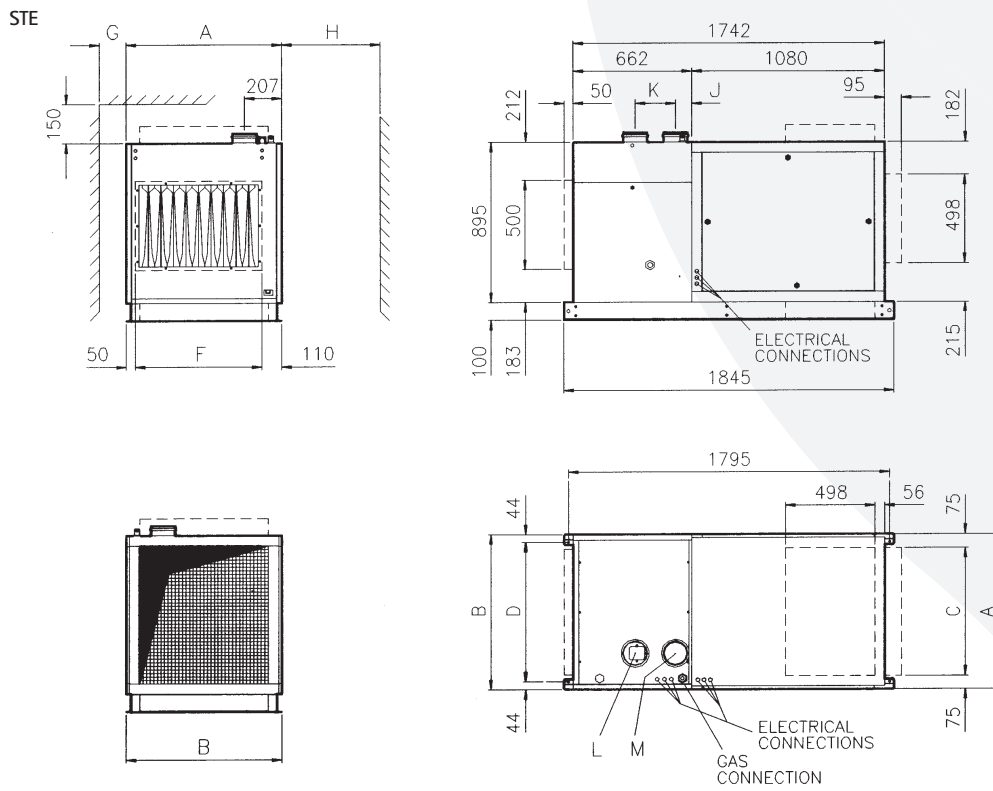

## STB and STE models

Model	100	125	150	175	225	300	400
A Cabinet width	520	590	730	730	870	1080	1360
B Overall width (STE models only)	524	594	734	734	874	1084	1364
C Duct inlet width (STE models only)	370	440	580	580	720	930	1213
D Suspension centres (STE models only)	436	506	646	646	786	996	1276
E Suspension centres (STB models only)	359	429	569	569	709	919	1199
F Duct outlet spigot width	360	430	570	570	710	920	1200
G Side clearance non control side	150	150	150	150	150	300	300
H Side clearance control side	550	620	750	750	900	1100	1400
J Heater back to air inlet	166	166	166	90	90	90	90
K Air inlet/flue outlet centres	140	140	140	140	225	225	225
L Flue spigot diameter	102	102	102	132	132	132	132
M Air inlet diameter	102	102	102	132	132	132	132
N Depth centrifugal fan (STB models only)	518	575	668	668	668	575	668

All dimensions are in millimetres.

## Specification UCB and UCE units

### Cabinets

All components exposed to the products of combustion are manufactured from aluminised steel and exterior panels have a powder coat finish. A flue collar is located on the top of the unit for connecting to a single wall conventional flue system, an adaptor will be required for other types of flue system.

UCE models are supplied complete with a galvanised steel base frame to allow either four point suspension or floor mounting in a plant room. Optional EU2 or EU4 filters can be fitted inside the fan cabinet and provide filtration to both the fresh air and return air, other grades of filtration are available on request.

Fan cabinets can be supplied with either single skin construction or fully insulated to suit individual application requirements.

### Heat exchanger

The heat exchanger is manufactured from special grade aluminised steel. For applications using fresh air optional stainless steel (AISI 409) heat exchangers are recommended. For areas where chlorinated vapours may be present corrosion resistant stainless steel (AISI 316) heat exchangers should be specified.

### Burners

Burners are mounted in a slide out tray. The burner tray may slide out from either the left or right of the heater (when facing the air discharge) and this must be clearly stated on the heater order.

### Gas and safety controls

A multi function gas control with permanent pilot and thermoelectric safety control are fitted as standard. Fully automatic electronic ignition may be fitted as an option. Fan operation is controlled by an integral fan control which delays fan start up until the heat exchanger has reached operating temperature. In addition it continues to operate the fan after the burners have shut down, until all useful heat has been dissipated into the building. For ventilation applications an optional constant fan relay can be fitted to provide constant fan operation controlled via a time switch.

Limit switch thermostats are fitted to monitor the operation of the heater and switch off the burner in the event of overheating, for additional safety an extra high limit thermostat is fitted on all EnviroAir units.

### Air handling

UCB and UCE units are provided as standard with a duct spigot outlet for connection to ductwork, for free blowing applications louvres and discharge nozzles are available as options and are ordered separately.

The units are suitable for a wide range of airflows and static pressures up to 400 pascals. A range of different size motors can be fitted in each unit to match the precise duty requirements.

## Technical data

### UCB and UCE models

Model		25	30	35	45	55	75	95
Nominal heat output	kW	24	28	34	41	51	70	93
Gas rate								
Natural gas G20	m <sup>3</sup> /h	2.89	3.33	4.13	4.97	6.17	8.49	11.33
Propane G31	kg/h	2.16	2.49	3.09	3.72	4.62	6.35	8.47
Gas connection†	BSP in	<sup>3</sup> / <sub>4</sub>	<sup>3</sup> / <sub>4</sub>	<sup>3</sup> / <sub>4</sub>	<sup>3</sup> / <sub>4</sub>	<sup>3</sup> / <sub>4</sub>	<sup>3</sup> / <sub>4</sub>	<sup>3</sup> / <sub>4</sub>
Flue spigot diameter	mm	130	153	181	181	202	202	252
Airflow @ 125Pa (standard motor)	m <sup>3</sup> /h	1800	2600	3050	3400	4200	5900	7000
Minimum airflow	m <sup>3</sup> /h	1350	1650	2000	2300	2900	4000	5000
Standard motor (230V single phase)	kW	0.18	0.37	0.37	0.37	0.55	0.75	0.75
Maximum motor size (three phase)	kW	1.1	1.1	1.5	1.5	2.2	3.0	3.0
Maximum airflow (with larger motor)	m <sup>3</sup> /h	3000	4000	5000	5000	7200	9000	12000
Approximate weight (UCB models only)*	kg	94	127	147	147	163	188	236
Approximate weight (UCE models only)*	kg	124	161	192	192	207	262	307

† The connection size on the heater does not indicate the size of gas supply pipework, gas pipework should be sized within allowable pressure drops to comply with current codes of practice.

Natural gas G20 calorific value 10.5 kWh m<sup>3</sup> GCV minimum inlet pressure 17.5 mbar, maximum inlet pressure 50 mbar.

Propane G31 calorific value 14.0 kWh m<sup>3</sup> GCV minimum inlet pressure 37 mbar, maximum inlet pressure 50 mbar.

\* Actual weight depends on options fitted.

# Dimensions

UCB

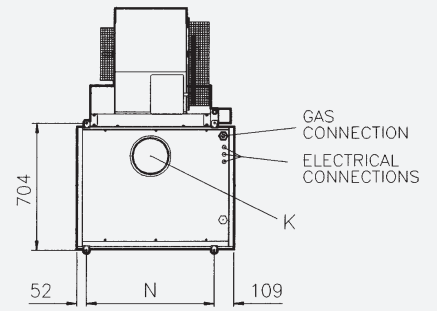
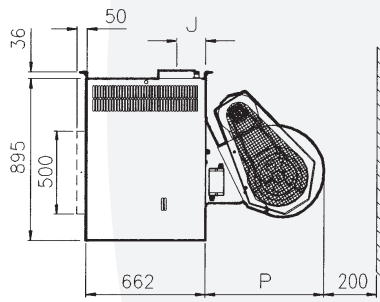
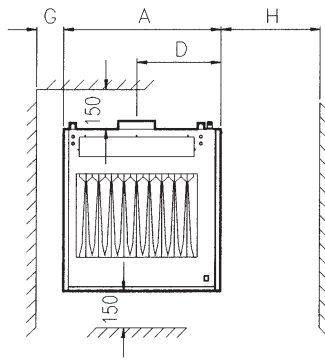

UCE

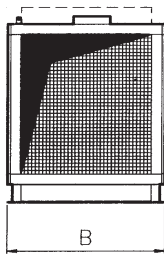
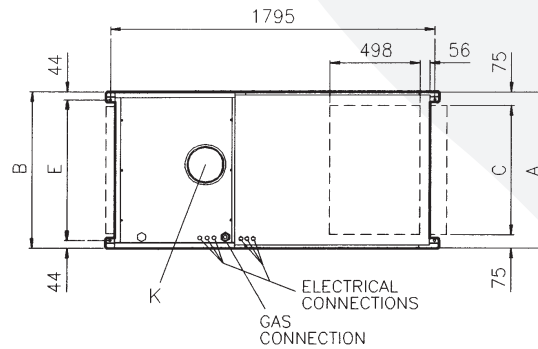
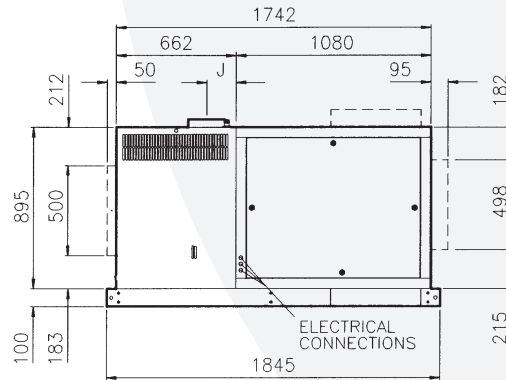
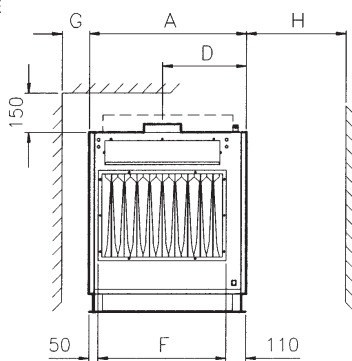

## UCB and UCE models

Model	25	30	35	45	55	75	95
A Cabinet width	520	590	730	730	870	1080	1360
B Overall width (UCE models only)	524	594	734	734	874	1084	1364
C Duct inlet width (UCE models only)	370	440	580	580	720	930	1210
D Access side to flue centre	290	325	395	395	465	570	710
E Suspension centres (UCE models only)	436	506	646	646	786	996	1276
F Duct outlet spigot width	360	430	570	570	710	920	1200
G Side clearance non control side	150	150	150	150	150	300	300
H Side clearance control side	550	620	750	750	900	1100	1400
J Cabinet back to flue outlet	127	137	151	151	162	162	169
K Flue spigot diameter	130	153	181	181	202	202	252
N Suspension centres (UCB models only)	359	429	569	569	709	919	1199
P Depth centrifugal fan (UCB models only)	518	575	668	668	668	575	668

All dimensions are in millimetres.



Ambi-Rad Limited Fens Pool Avenue  
Brierley Hill West Midlands  
DY5 1QA United Kingdom

Telephone 01384 489700  
Facsimile 01384 489707  
UK sales email [sales@ambirad.co.uk](mailto:sales@ambirad.co.uk)  
Website [www.ambirad.co.uk](http://www.ambirad.co.uk)

**AMBIRAD** is the registered  
trademark of Ambi-Rad Limited.

Due to continuous product  
innovation, Ambi-Rad reserves  
the right to change product  
specification without due notice.

**AMBIRAD**  
ENERGY EFFICIENT HEATING SYSTEMS



An Ambi-Rad Group company