



0063

This appliance is for use with natural or propane gas. Read these instructions thoroughly before commencing installation.

AMBI-RAD Models STA, STB, STE Fan-Assisted, Balanced-Flue, Gas-Fired Unit Heaters

Installation Form WA/016/0697

APPLIES TO: Installation, Commissioning, and Service

Table of Contents

1.0 Introduction

- 1.1 Basic Information
- 1.2 Warranty

2.0 Technical Data

- 2.1 Specifications
 - 2.1.1 STA Specifications
 - 2.1.2 STB and STE Specifications
- 2.2 Burner Injector Size and Pressure
- 2.3 Dimensions
 - 2.3.1 Dimensions - STA Models
 - 2.3.2 Dimensions - STB Models
 - 2.3.3 Dimensions - STE Models

3.0 General Requirements

- 3.1 Related Documents
- 3.2 Heater Locations
- 3.3 Flue/Combustion Air System
- 3.4 Gas Supply
- 3.5 Air Distribution System
- 3.6 Electrical Supply

4.0 Installation

- 4.1 Uncrating and Preparation
- 4.2 Fitting the Heater

4.3 Fitting the Flue/Combustion Air System

- 4.3.1 Flue Pipe
- 4.3.2 Combustion Air Pipe
- 4.4 Gas Connection
- 4.5 Electrical Connections
- 4.6 Room Thermostat Siting

5.0 Air Distribution Systems

- 5.1 Horizontal Louvres
- 5.2 Vertical Louvres (Option)
- 5.3 Downturn Air Nozzles (Option)
- 5.4 Fitting Outlet Duct - Models STB, STE
- 5.5 Fitting Return Air Duct - Model STE

6.0 Commissioning and Testing

- 6.1 Electrical Check
- 6.2 Gas Connection
- 6.3 Suspension and Support
- 6.4 Lighting the Heater
- 6.5 Heater Pipework
- 6.6 Adjustments - Main Burner and Pilot
- 6.7 Air Distribution System
- 6.8 Heater Controls
- 6.9 Handing Over

7.0 Servicing Instructions

- 7.1 Requirements and Procedure

8.0 Removal and Replacement of Parts

- 8.1 Main Burner
- 8.2 Pilot Burner Injector
- 8.3 Pilot Burner Assembly
- 8.4 Pilot Ignition System
- 8.5 Main Burner Injectors
- 8.6 Blower Motor - STB, STE
- 8.7 Fan Motor/Blade - STA
- 8.8 Multifunctional Control Valve
- 8.9 Limit and Energy Cutoff Controls
- 8.10 Fan Temperature Control

9.0 Circuit Diagrams

- 9.1 Site Wiring Connections
- 9.2 Model STA
- 9.3 Models STB and STE

10.0 Fault Finding Charts

11.0 Exploded Diagrams

12.0 Short List of Parts

WARNING: Improper installation, adjustment, alteration, service or maintenance can cause injury or property damage. All work must be carried out by competent persons, i.e. a registered CORGI installer.

PLEASE READ THESE INSTRUCTIONS THOROUGHLY BEFORE COMMENCING WORK.

HAZARD INTENSITY LEVELS

1. **DANGER:** Failure to comply will result in severe personal injury or death and/or property damage.
2. **WARNING:** Failure to comply could result in severe personal injury or death and/or property damage.
3. **CAUTION:** Failure to comply could result in minor personal injury and/or property damage.

WARNING: The electrical isolator should only be used in an emergency and should not be used for closing down the main burner, as it switches off the fan prematurely and may damage the heat exchanger, invalidating the warranty.

When the external controls call for heat, the power venter activates, the pilot flame ignites, the multifunctional control valve opens, and the main burner ignites supplying heat to the heat exchanger. After approximately 30 seconds the air delivery fan will start to run and supply warm air.

When the required room temperature is reached, the main burner will shut down leaving the fan running to cool down the heat exchanger. When cool enough, the fan thermostat will turn off the fan.

1.2 Warranty

Warranty is void if ...

- a. Heater is installed in atmospheres containing flammable vapours or atmospheres containing chlorinated or halogenated hydrocarbons or atmospheres containing any silicone, aluminum oxide, etc. that adheres to spark ignition flame sensing probes.
- b. The installation is not in accordance with these instructions.
- c. Axial fan-type unit heater, is connected to a duct system or fitted with a non-factory authorised air distribution device.

1.0 INTRODUCTION

1.1 Basic Information

The instructions in this manual apply to Model ST Series fan-assisted, balanced flue, warm air heaters. Model STA heaters have an axial fan for air delivery. Models STB and STE have a centrifugal blower for air delivery and are intended for installation with or without ductwork. Model STE heaters include a blower cabinet. The ST Series heaters are designed for either overhead suspension or mounting on a non-combustible surface and are suitable for indoor installation only.

Model ST Series heaters are 80% thermal efficient and are designed for reduced NOx emission. A permanent electricity supply of 220-240 volts, 50 Hz, single phase is required for all STA Models. Models STB and STE may use either single phase or three phase.

Models ST Series heaters are approved for:

Type C₁₂ - horizontal vent for balanced-flue heaters;

Type C₃₂ - vertical vent for balanced-flue heaters;

Category II_{2H3P} - use with G20 natural gas or G31 propane gas.

Each unit is fitted with an intermittent pilot. A spark ignition/flame supervision device monitors the pilot flame to prevent an explosive condition occurring.

2.0 TECHNICAL DATA

2.1 Specifications

Figure 1A - Model STA



**Front View of a
Model STA300**

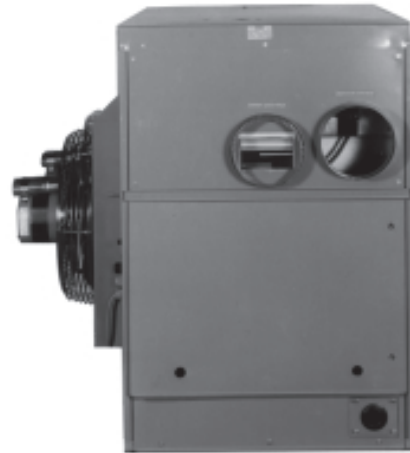

Control Side View

2.1.1 TABLE 1 - Model STA SPECIFICATIONS

Size	Heat Input		Heat Output		Maximum Gas Rate ① for G20 Natural Gas	Maximum Gas Rate ② for G31 Propane Gas	Air Volume	Running Amps③	Power ③ Consumption	Fuse Size
	kw	BTUH	kw	BTUH	m ³ /hr	m ³ /hr	m ³ /hr			
100	29.3	100,000	23.4	80,000	2.73	1.11	2040	1.4	340	5
125	36.6	125,000	29.3	100,000	3.41	1.39	2460	1.4	340	5
150	43.9	150,000	35.1	120,000	4.10	1.67	3300	1.4	340	5
175	51.3	175,000	41.0	140,000	4.78	1.95	3300	1.4	340	5
200	58.6	200,000	46.9	160,000	5.46	2.23	4260	1.9	475	5
225	65.9	225,000	52.4	178,875	6.15	2.50	4260	1.9	475	5
250	73.2	250,000	58.6	200,000	6.83	2.78	5700	2.4	580	5
300	87.9	300,000	69.8	238,500	8.20	3.34	5700	2.4	580	5
350	102.5	350,000	81.5	278,250	8.57	3.90	6600	3.3	850	7.5
400D	102.5	350,000	82.0	280,000	8.57	3.90	7560	3.3	850	7.5
400	117.1	400,000	93.1	318,000	10.95	4.45	7560	3.3	850	7.5

① Gas flow rate is based on a gas with a gross C.V. of 39.9 MJ/m³ (1030 BTUH) and includes a pilot flow rate of 264 watts (900 BTUH)

② Gas flow rate is based on a gas with a gross C.V. of 101.6 MJ/m³ (2500 BTUH) and includes a pilot flow rate of 264 watts (900 BTUH)

③ Based on normal operation at 240 volts and 50 hertz.

2.1.2 TABLE 2A - Model STB and Model STE SPECIFICATIONS

Size	Heat Input		Heat Output		Maximum Gas Rate① for G20 Natural Gas	Maximum Gas Rate ② for G31 Propane Gas	Blower	Air Volume③ Free Blow		Air Volume③ Flow @ 125 Pa		④ Running Amps	④ Power Consumption	④ Fuse Size
	kw	BTUH	kw	BTUH	m ³ /hr	m ³ /hr	RPM	m ³ /hr	Rise °C	m ³ /hr	Rise °C			
100	29.3	100,000	23.4	80,000	2.73	1.11	700	2550	27	1700	41	5.8	796	10
125	36.6	125,000	29.3	100,000	3.41	1.39	700	3400	26	2150	41	5.8	796	10
150	43.9	150,000	35.1	120,000	4.10	1.67	670	4000	26	2550	41	5.8	796	10
175	51.3	175,000	41.0	140,000	4.78	1.95	670	4075	30	3000	41	5.8	796	10
200	58.6	200,000	46.9	160,000	5.46	2.23	710	5000	28	3400	41	6.0	979	10
225	65.9	225,000	52.4	178,875	6.15	2.50	710	5600	28	3800	41	6.0	979	10
250	73.2	250,000	58.6	200,000	6.83	2.78	810	6400	27	4250	41	7.5	1125	15
300	87.9	300,000	69.8	238,500	8.20	3.34	810	7650	27	5100	41	7.5	1125	15
350	102.5	350,000	81.5	278,250	8.57	3.90	810	8500	29	5950	41	8.8	1529	15
400D	102.5	350,000	82.0	280,000	8.57	3.90	770	8500	29	5950	36	8.8	1529	15
400	117.1	400,000	93.1	318,000	10.95	4.45	770	8850	32	6800	37	8.8	1529	15

① Gas flow rate is based on a gas with a C.V. of 39.9 MJ/m³ (1030 BTUH) and includes a pilot flow rate of 264 watts (900 BTUH)

② Gas flow rate is based on a gas with a C.V. of 101.6 MJ/m³ (2500 BTUH) and includes a pilot flow rate of 264 watts (900 BTUH)

③ Air flow capability with standard blower motor. (Pulley adjustment may be necessary.)

④ Based on normal operation at 240 volts and 50 hertz with standard motor. Refer to **TABLE 2B**, Optional Motor Table, for motor amps and power consumption ratings when equipped with other-than-standard motors.

2.1.2 TABLE 2B - STANDARD MOTOR SIZE, Model STB or STE		
STB or STE Size	Blower Motor	
	kw	HP
100, 125, 150, 175	0.375	0.5
200, 225	0.56	0.75
250, 300	0.73	1
350, 400D, 400	1.12	1.5

2.1.2 TABLE 2C - ELECTRICAL SPECIFICATIONS of Model STB or STE with OPTIONAL MOTOR									
Blower Motor	kw	0.375	0.56	0.73	1.12	0.75	1.12	1.5	2.25
	HP	0.5	0.75	1	1.5	1	1.5	2	3
Voltage		220-240 V, 1 PH, 50 Hz				400-415 V, 3 Ph, 50 Hz			
Starting Current	20.1	26	37.5	41.7	12.4	17.2	22.3	27.3	
Running Current	5.4	5.6	7.5	7.8	2.0	2.8	3.4	4.9	
Power Consumption	696	879	1025	1429	1023	1459	1831	2750	
Fuse Size	10	10	15	15	5	5	7.5	7.5	

2.2 Burner Injector Size and Pressure

Natural Gas

2.2.1 TABLE 3 - G20 (Natural) GAS INJECTOR SIZE, BURNER PRESSURE, AND INLET PRESSURE								
Size	Injector Quantity	Injector Size	Injector Marking	Burner Pressure		Minimum Inlet Pressure	Maximum Inlet Pressure	Gas Rate Per Burner
		mm		mbar	in. w.g.	mbar	mbar	M ³ /Hr
100	4	2.35	42	8.5	3.4	12.5	30	0.69
125	5	2.35	42	8.5	3.4	12.5	30	0.69
150	7	2.20	44	9.0	3.6	14.0	30	0.59
175	7	2.35	42	8.5	3.4	16.0	30	0.69
200	9	2.25	43	8.5	3.4	12.5	30	0.61
225	9	2.35	42	8.5	3.4	12.5	30	0.69
250	12	2.20	44	8.5	3.4	15.0	30	0.57
300	12	2.35	42	8.5	3.4	15.0	30	0.69
350	14	2.35	42	8.5	3.4	17.0	30	0.69
400 D	16	2.35	42	7.0	2.8	17.0	30	0.60
400	16	2.35	42	8.5	3.4	17.5	30	0.69

Propane Gas

2.2.2 TABLE 4 - G31 (Propane) GAS INJECTOR SIZE, BURNER PRESSURE AND INLET PRESSURE								
Size	Injector Quantity	Injector Size	Injector Marking	Burner Pressure		Minimum Inlet Pressure	Maximum Inlet Pressure	Gas Rate per Burner
		mm		mbar	in. w.g.	mbar	mbar	M ³ /Hr
100	4	1.45	1.45	25.0	10.0	27	35	0.28
125	5	1.45	1.45	25.0	10.0	27	35	0.28
150	7	1.35	1.35	25.0	10.0	27	35	0.24
175	7	1.45	1.45	25.0	10.0	28	35	0.28
200	9	1.40	54	25.0	10.0	28	35	0.25
225	9	1.45	1.45	25.0	10.0	28	35	0.28
250	12	1.35	1.35	25.0	10.0	30	35	0.23
300	12	1.45	1.45	25.0	10.0	30	35	0.28
350	14	1.45	1.45	25.0	10.0	30	35	0.28
400 D	16	1.35	1.35	25.0	10.0	30	35	0.24
400	16	1.45	1.45	25.0	10.0	30	35	0.28

2.3 DIMENSIONS

2.3.1 Dimensions of Standard Model with Axial-Fan for Air Delivery

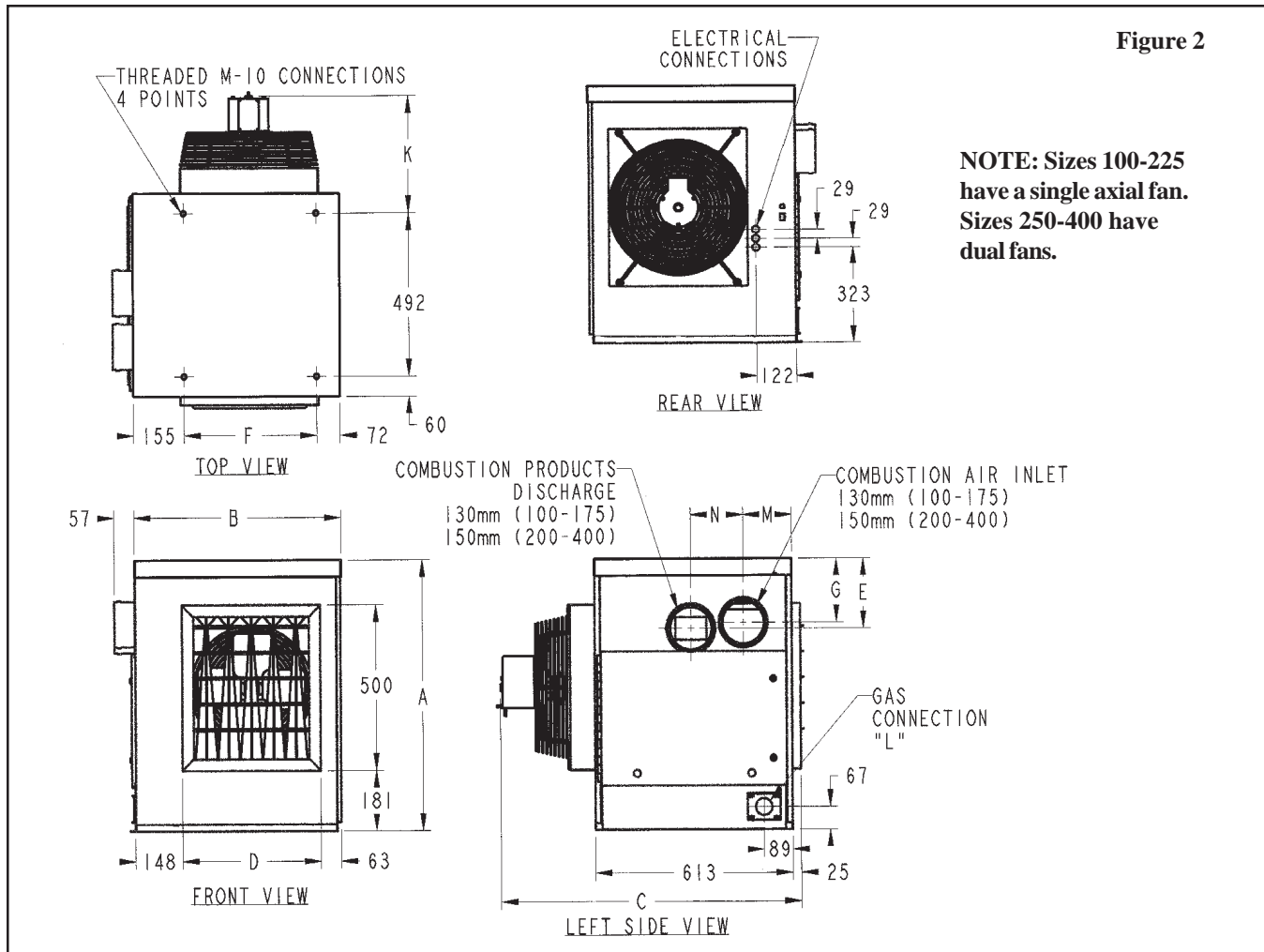

TABLE 5

Model STA	A mm	B mm	C mm	D mm	E mm	F mm	G mm
100	819	571	865	360	194	343	181
125	819	641	908	430	194	413	181
150	819	780	927	570	194	553	181
175	819	780	927	570	194	553	181
200	895	920	929	710	255	692	234
225	895	920	929	710	255	692	234
250	895	1130	921	919	255	902	234
300	895	1130	921	919	255	902	234
350	895	1269	929	1059	255	1042	234
400D	895	1409	929	1199	255	1181	234
400	895	1409	929	1199	255	1181	234

Model STA	K mm	L BSP in	M mm	N mm
100	288	1/2	151	165
125	331	1/2	151	165
150	350	1/2	151	165
175	350	1/2	151	165
200	352	1/2	119	188
225	352	1/2	119	188
250	344	1/2	119	188
300	344	3/4	119	188
350	352	3/4	119	188
400D	352	3/4	119	188
400	352	3/4	119	188

2.3.2 Dimensions of Standard Model with Centrifugal Blower (less Cabinet) for Air Delivery

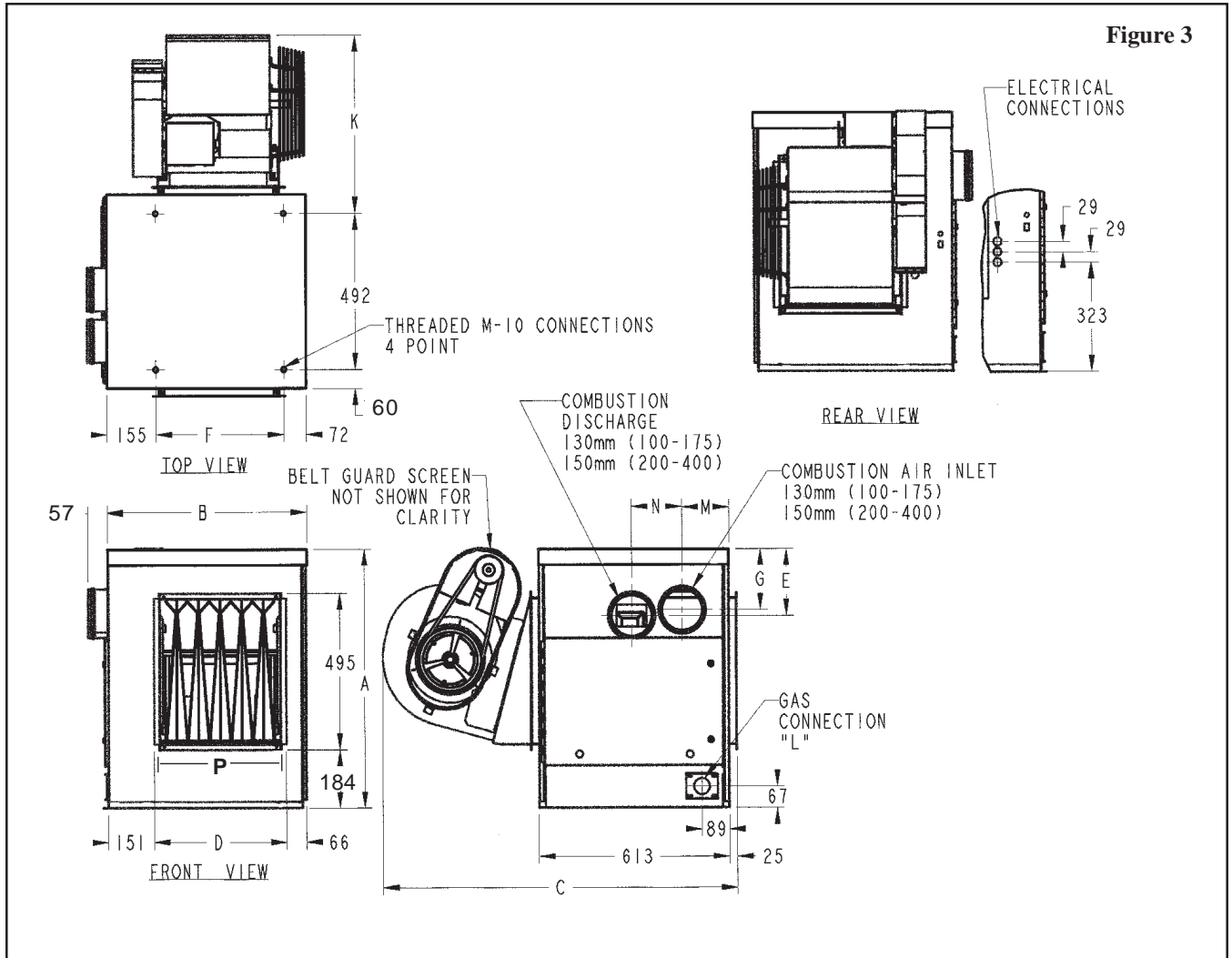

TABLE 6

Model	A	B	C	D	E	F	G
STB	mm	mm	mm	mm	mm	mm	mm
100	819	571	1133	355	194	343	181
125	819	641	1133	425	194	413	181
150	819	780	1226	565	194	553	181
175	819	780	1226	565	194	553	181
200	895	920	1226	705	255	692	234
225	895	920	1226	705	255	692	234
250	895	1130	1133	914	255	902	234
300	895	1130	1133	914	255	902	234
350	895	1269	1226	1054	255	1042	234
400D	895	1409	1226	1194	255	1181	234
400	895	1409	1226	1194	255	1181	234

Model	K	L	M	N	P
STB	mm	BSP in	mm	mm	mm
100	556	1/2	151	165	317
125	556	1/2	151	165	387
150	649	1/2	151	165	527
175	649	1/2	151	165	527
200	649	1/2	119	188	667
225	649	1/2	119	188	667
250	556	1/2	119	188	876
300	556	3/4	119	188	876
350	649	3/4	119	188	1016
400D	649	3/4	119	188	1156
400	649	3/4	119	188	1156

2.3 DIMENSIONS (cont'd)

2.3.3 Dimensions of Standard Model with a Blower Cabinet

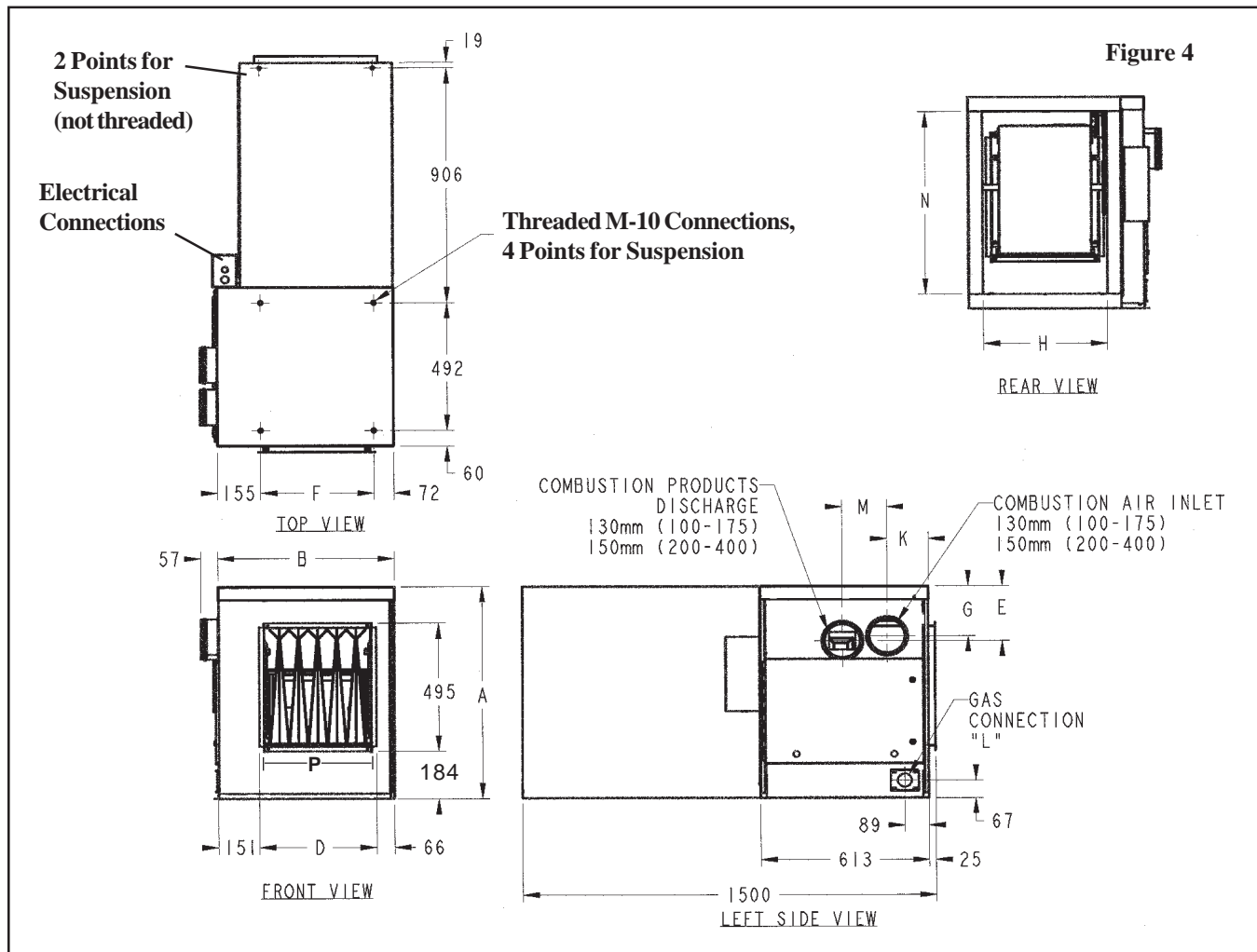

TABLE 7

Model STE	A	B	D	E	F	G	H
	mm	mm	mm	mm	mm	mm	mm
100	819	571	355	194	343	181	451
125	819	641	425	194	413	181	451
150	819	780	565	194	553	181	591
175	819	780	565	194	553	181	591
200	895	920	705	255	692	234	730
225	895	920	705	255	692	234	730
250	895	1130	914	255	902	234	940
300	895	1130	914	255	902	234	940
350	895	1269	1054	255	1042	234	1080
400D	895	1409	1194	255	1181	234	1219
400	895	1409	1194	255	1181	234	1219

Model STE	K	L	M	N	P
	mm	BSP in	mm	mm	mm
100	151	1/2	165	706	317
125	151	1/2	165	706	387
150	151	1/2	165	706	527
175	151	1/2	165	706	527
200	119	1/2	188	783	667
225	119	1/2	188	783	667
250	119	1/2	188	783	876
300	119	3/4	188	783	876
350	119	3/4	188	783	1016
400D	119	3/4	188	783	1156
400	119	3/4	188	783	1156

3.0 GENERAL REQUIREMENTS

3.1 Related Documents

It is important that all gas appliances are installed by competent persons, i.e. a registered CORGI installer, in accordance with the relevant requirements of the following regulations.

Failure to install appliances correctly could lead to prosecution. It is in your own interest and that of safety to ensure compliance with the law.

THE RELEVANT REGULATIONS ARE ...

GAS SAFETY (INSTALLATIONS & USE) (Amendment) REGULATIONS 1990

THE HEALTH AND SAFETY AT WORK, ETC. ACTS

- **BS6230 1991** SPECIFICATION FOR THE INSTALLATION OF GAS FIRED FORCED CONVECTION AIR HEATERS FOR COMMERCIAL AND INDUSTRIAL SPACE HEATING OF RATED INPUT EXCEEDING 60 KW.
- **BS5588 PART 1 (SECTION 1) 1990; PART 2 1985 AND 1990; AND PART 3 1983 AND 1989**
- **BS5440 PART 2 1989** FLUES AND AIR SUPPLY FOR GAS APPLIANCES NOT EXCEEDING 60 KW
- **BS6891 1988** LOW PRESSURE INSTALLATION PIPES

BRITISH GAS PUBLICATIONS

IGE/UP/1 PURGING PROCEDURES FOR NON-DOMESTIC INSTALLATIONS and **SOUNDNESS TESTING PROCEDURES FOR INDUSTRIAL INSTALLATIONS**

I.E.E. REGULATIONS FOR ELECTRICAL INSTALLATIONS AND THE REQUIREMENTS OF THE FOLLOWING...THE LOCAL REGION OF BRITISH GAS Plc

WARNING: Air heaters should not be installed in corrosive atmospheres, i.e., near plating or degreasing plants or in areas where there is a fire risk. Consult BS6230 for further information on hazardous areas.

3.3 Combustion Air Inlet Pipe & Flue Pipe

These balanced-flue heaters are designed to be fitted with a combustion air inlet pipe that obtains air for combustion from the outside atmosphere and a flue pipe that expels flue gases to the outside atmosphere.

The unit is fitted with a power venter permitting either a vertical or a horizontal combustion air inlet/flue pipe system. **The heaters must be fitted with a concentric vertical or horizontal flue/air inlet. The units are only approved for use when used with the appropriate system which is available from AMBI-RAD.**

Flue pipe and combustion air pipe runs must be sealed. Use sealed, seamless aluminum pipe or equivalent.

The flue pipe must include a resealable test port. To ensure a good average sample of flue gas mixture for testing, the port must be at least 456 mm away from the heater socket connection.

Follow the pipe manufacturer's installation instructions for making joints, including heater connections; for passing through a wall or ceiling; and for support requirements. If more than one heater is installed, each unit must have an individual combustion air inlet/flue pipe system.

3.2 Heater Location

The location chosen for the heater must permit the provision of a satisfactory combustion air and flue system. The location must also provide required clearances and adequate space for servicing.

All Sizes	Top	Sides		Bottom	
		Control	Other	To Combustibles	To Non-Combustibles
mm	152	See Note	152	152	0

NOTE: Service Clearance for Control Side is the width of the unit plus 152mm in order to remove the drawer-type burner rack.

Refer to Table 9 for recommended mounting height for heaters equipped with axial fan(s) for air delivery.

Size	100-150	175-250	300-400
Mounting Height	2.5-3 m	2.5-3.5 m	3-5 m

Units should always be arranged to blow toward or along exposed wall surfaces, if possible. Where two or more units are installed in the same room, a general scheme of air circulation should be maintained for best results.

Suspended heaters are most effective when located as close to the working zone as possible. However, care should be exercised to avoid directing the discharge air directly on the room occupants.

Partitions, columns, counters, or other obstructions should be taken into consideration when locating the unit heater so that a minimum quantity of air will be deflected by any such obstacles. When units are suspended in the centre of the space to be heated, the air should be discharged along exposed walls. In large areas, units should be located to discharge air along exposed walls with extra units provided to discharge air in toward the centre of the area. At those points where infiltration of cold air is excessive, such as at entrance doors and loading doors, it is desirable to locate the unit(s) so tempered air is discharged directly toward the source of cold air from a distance of 4.5 to 6.0 meters (15 to 20 ft). The use of downturn 30°, 60°, or 90° nozzles is also recommended.

Size			100	125	150-175	200-250	300-400	
Heater Spigot Diameter	Flue Pipe	mm	130	130	130	150	150	
	Inlet Pipe	mm	130	130	130	150	150	
Pipe Diameter	Flue Pipe	mm	110 or 130	110 130	130	150	150	180
	Inlet Pipe	mm	110 or 130	110 130	130	130 or 150	150	180
Maximum Straight Length	Flue Pipe	m	10	10 12	12	12	11	18
	Inlet Pipe	m	10	10 12	12	12	11	18
Equivalent Length of Elbow	Both Pipes	m	2.5	2.5 3	3	3	3.5	
Concentric Vertical Vent			Ambi-Rad P/N CV100			Ambi-Rad P/N CV130		
Concentric Horizontal Vent			Ambi-Rad P/N CH100			Ambi-Rad P/N CH130		

3.0 GENERAL REQUIREMENTS (cont'd)

3.4 Gas Supply

These heaters are designed to operate on either G20 natural gas or G31 propane gas. Refer to Tables 3 and 4 or the data plate for minimum and maximum supply pressure.

The gas meter and service must be checked by the gas supplier to ensure that it is adequate to deal with the total connected load of the completed installation.

The installation must comply with British Standard 6891, and the complete installation including the meter must be purged and tested for soundness as described in the above standard and in British Gas Document IGE/UP/1.

3.5 Air Distribution System

Recommendations for the air distribution system are given in the document entitled "Standards of Installation for Gas Fired Industrial Warm Air Heaters".

The following notes are of particular importance...

"For free-blowing units, it must be taken into account that the buoyancy of the heated air leaving the heater and air patterns with the space being heated will modify the air throw pattern achieved.

In buildings having a low heat loss where single units are required to cover a large floor area and in buildings with high roof or ceiling heights, air recirculation may be fitted to ensure even heat distribution and minimise stratification respectively. Care should be taken to avoid impeding the air throw with racking, partitions, plant machinery, etc."

Various outlet configurations are available as optional extras to modify the air throw pattern to suit particular site conditions. (See Section 5).

3.6 Electrical Supply

Wiring external to the air heater must be installed in accordance with the I.E.E. Regulations and be carried out by a qualified electrician.

A constant 220-240V, 50 Hz single phase supply is required for all heaters equipped with axial fan(s) for air delivery. Depending on the electrical components, heaters with a centrifugal blower may use either 220-240V, 50 Hz single phase or 415V, 50Hz three phase supply. All heaters

and controls must be correctly earthed. An isolator with a contact separation of at least 3 mm on all poles should be installed adjacent to the heater.

When a number of heaters are to be wired as part of a single installation, each heater must be provided with a separate isolator.

Electrical supply entrance is on the rear of the heater. The final connection to the heater should be to the appliance terminal block in the heater electrical box. See Figure 5 and the connection diagram in Paragraph 9.1.

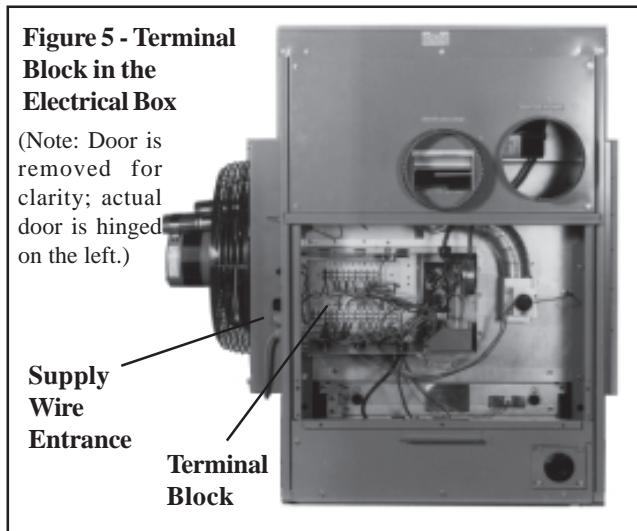

Supply cable size should be 1.0 mm for a model equipped with an axial fan. Larger cable may be required for heaters with a centrifugal blower. See Section 2, Technical Data, for required fuse size.

Fit the cord anchor supplied with the heater. The length of the conductors between the cord anchorage and the terminals must be such that the current-carrying conductors become taut before the earthing conductor, if the cable or cord slips out of the cord anchorage.

4.0 INSTALLATION

4.1 Uncrating and Preparation

Prior to despatch, the unit was operated and tested at the factory. If the heater has incurred any damage in shipment, file a claim with AMBI-RAD within 48 hours.

Check the data plate for the gas specifications and electrical characteristics of the heater to be sure that they are compatible with the gas and electric supplies at the installation site. Read this booklet and become familiar with the installation requirements of your particular heater. Before beginning, make preparations for necessary supplies, tools, and manpower.

Check to see if there are any site-installed options that need to be fitted on the heater prior to installation. Each of the option packages includes a list of components and complete, step-by-step instructions. For a brief explanation of frequently specified site-installed options, see Section 5. After becoming familiar with the instructions, assemble and install the options that are required for your heater.

4.2 Fitting the Heater

Before fitting the heater, check the supporting structure to be used to verify that it has sufficient load-carrying capacity to support the weight of the unit and the ancillary equipment. See weights in Table 11.

Where the location of the air heater is such that it might

Model with following type of Air Delivery Equipment	kg	Size						
		100	125	150 175	200 225	250 300	350	400D 400
With Axial Fan	kg	90	96	104	143	175	195	220
With Blower	kg	100	128	147	158	188	208	234
With Blower and Cabinet	kg	118	142	163	173	219	226	254

suffer external mechanical damage, i.e., from overhead cranes, fork lift trucks, it must be suitably protected.

When lifting a centrifugal-blower unit, support the blower and motor to prevent the unit from tipping. When lifting a unit with a blower cabinet, support the blower cabinet. Blower models may have legs to support the blower assembly during shipping. After the unit is fitted at the site, these legs should be removed.

Material used to support any heater whether suspended or base mounted should be corrosion resistant and of sufficient strength. The gas supply pipe and electrical connections should not support any of the weight of the heater.

WARNING: Units must be level for proper operation. Do not place or add additional weight to the heater.

4.2.1 Suspending the Heater

All heaters are equipped with four suspension brackets. Blower models must be suspended with rigid support material. Do not use chain or flexible support material for heaters with centrifugal blowers.

WARNING: Suspend the heater only from the hanger brackets. Do not suspend from the heater side or top panel.

4.2.2 Mounting the Heater

These heaters may be base mounted on a non-combustible support. Always ensure the heater is adequately secured.

Figure 6 - Suspension Dimensions

Size	A
	mm
100	343
125	413
150/175	553
200/225	692
250/300	902
350	1042
400D/400	1181

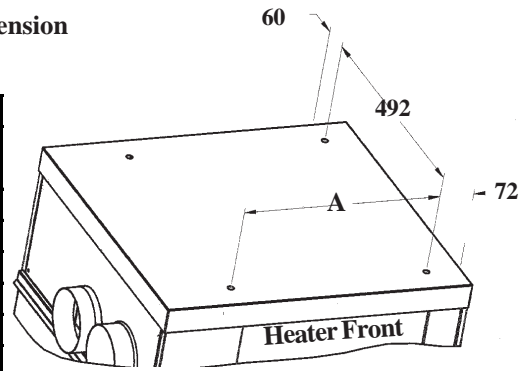

4.3 Fitting the Combustion Air Inlet /Flue Pipe System (See Figures 7A and 7B)

Flue pipe runs may be horizontal or vertical and terminate either through a wall or roof. Minimum length is 1.5 m. See Table 10 for maximum lengths and approved site-supplied concentric terminals.

NOTE: If the diameter selected for the pipe run is different from the socket size, make the transition at the heater with a taper-type connection.

All pipe runs should be supported so that the heater does not carry any of the weight of the pipes.

Figure 7A - Concentric Terminal Arrangements

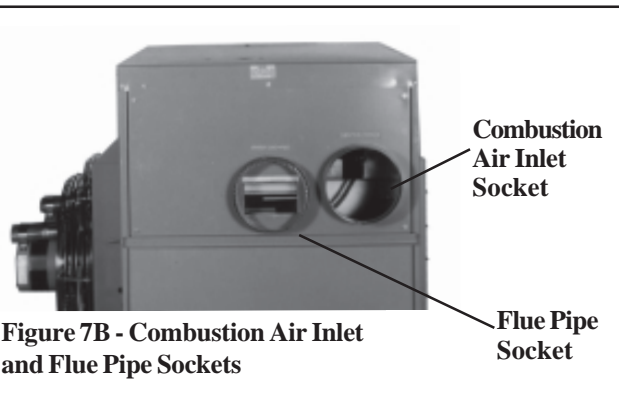
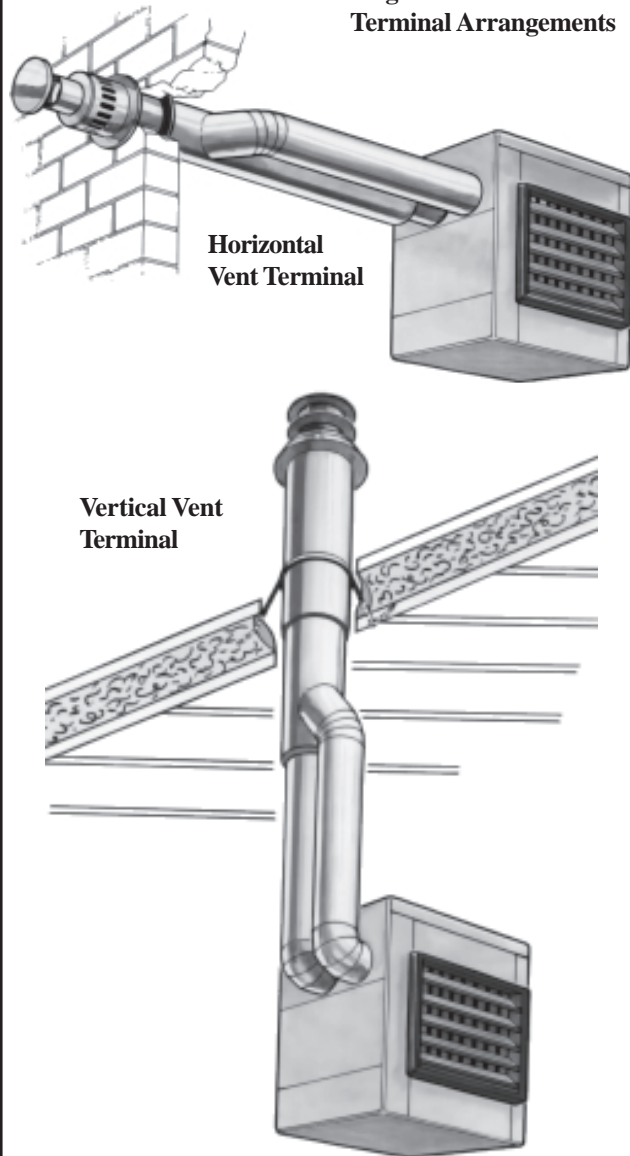

Figure 7B - Combustion Air Inlet and Flue Pipe Sockets

4.3.1 Fitting the Flue Pipe

The flue pipe socket is located on the control side of the heater.

Flue pipe must be sealed. Use seamless, aluminum pipe or equivalent. Follow pipe manufacturer's installation instructions.

TABLE 12A - Flue Pipe Socket Size

Heater Sizes	Flue Pipe Socket (mm)
100 - 175	130
200 - 400	150

4.3.2 Fitting the Combustion Air Inlet Pipe

The combustion air pipe attaches directly to the inlet socket on the control side of the heater. Air inlet pipe must be sealed. Use seamless, aluminum pipe or equivalent. Follow pipe manufacturer's installation instructions.

TABLE 12B - Air Inlet Socket Size

Heater Sizes	Combustion Air Inlet Socket (mm)
100 - 175	130
200 - 400	150

4.4 Gas Connection

To facilitate servicing, the heater must be fitted with an approved service gas cock and union or union cock.

The inlet gas supply line must be installed appropriately to permit the centre access door to be opened and to allow removal of the slide-out burner tray. A recommended arrangement is shown in Figure 8. **An approved service gas cock and union or union cock must be fitted.**

Heaters suspended by flexible support material or drop rods should be connected to the gas service using a flexible connector. Sufficient slack must be provided in the flexible connector to allow for normal movement of the heater. Use a flexible connector of suitable size to reduce pressure drop and the possibility of flow noise.

Warning: Do not use the gas supply connection to balance heater or support any weight of the heater.

4.0 INSTALLATION (cont'd)

4.4 Gas Connection (cont'd)

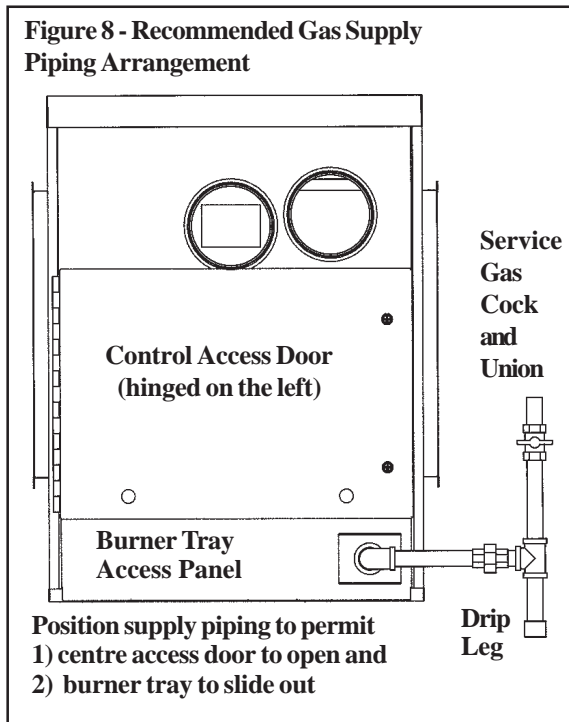

4.5 Electrical Connections

All electrical connections should be made in the heater terminal box (refer to Figure 5). Screw-type terminals are provided. Connections should be in accordance with terminal markings and the wiring diagram affixed to the heater or shown in Section 9.

The minimum control scheme must have a room thermostat, and in all cases, **it is essential that the main input to terminals L and N remains alive at all times to ensure the correct operation of the fan/blower.** Control panels that incorporate time and temperature control and/or remote reset are available from AMBI-RAD.

A factory-fitted indicator light and reset button are on the rear of the unit. (Refer to Figure 8.) To add a remote button, make connections to the terminal strip in the electrical box as indicated on the wiring diagram. **CAUTION: The cause for activating the lockout control should be identified and corrected before resetting. If the first reset is not successful, wait 15 seconds before pushing the reset button.**

4.6 Room Thermostat Siting

The siting of the thermostat or panel is particularly important. It should not be fitted on an outside wall. Avoid locating the thermostat in draughty areas or where it may be directly exposed to heat from the sun or other heat sources. The thermostat or panel should be mounted on an internal wall or column about 1.5m above the floor. Follow the thermostat manufacturer's instructions when fitting a thermostat. The thermostat must be suitable for switching 240 volts.

Do not attempt to control more than one heater from a thermostat or panel unless a properly wired relay is fitted. If correctly fitted with relays, a thermostat or panel can be used to control several heaters. An AMBI-RAD SU4 slave panel allows up to four heaters to be controlled from a single panel.

5.0 AIR DISTRIBUTION SYSTEMS -- Standard and Optional

5.1 Horizontal Louvres

Model STA heaters are factory supplied with adjustable horizontal louvres. Model STB and STE heaters are factory supplied less louvres for direct attachment to ductwork. For free blowing applications, optional horizontal louvre frames may be added to a Model STB or STE heater. Horizontal louvres may be adjusted from 10 to 55 degrees to direct the airflow down to the floor. **IMPORTANT:** Do not adjust the louvres beyond their stops.

5.2 Optional Vertical Louvres

Louvre frames can be fitted with optional vertical louvres to increase the air pattern spread. This option is normally used on heaters that are installed at minimum mounting heights. The vertical louvre assembly is designed to be assembled and fitted at the installation site.

5.3 Optional Downturn Air Nozzles

Heaters can be fitted with optional downturn nozzles to direct the discharge air toward the floor. Downturn nozzles are recommended for Sizes 100-175 installed above 3m and Sizes 200-400 installed above 4m. Downturn nozzles should always be fitted to units mounted above the recommended heights in Table 9.

A 30° downturn nozzle changes discharge air direction up to 57°. A 60° downturn nozzle changes discharge air direction up to 90°. A 30° downturn nozzle may be used with vertical louvres. Do not fit vertical louvres on an axial fan heater with a 60° downturn nozzle. When vertical louvres are required with a 60° nozzle, a centrifugal fan unit must be used. A 90° nozzle with optional two-way or four-way discharge plenum is also available for centrifugal fan models.

All downturn nozzles are designed for site assembly and fitting.

5.4 Fitting Outlet Ductwork - Model STB and Model STE

Low heat capacity materials should be used for the construction of warm air delivery and should be insulated when passing through

unheated spaces. Joints and seams of all outlet air ducts and fittings must be securely fastened and made airtight.

All ducting must be securely supported in such a way that there is no undue strain. The heater should not be used to provide any support for the ductwork. If equipped with louvres, remove the louvres and louvre frame before attaching ductwork.

NOTE: Always attach ductwork to flanges; do not attach ductwork to heater cabinet.

Heater Size	Width	Height
	mm	mm
100	317	462
125	387	462
150 - 175	527	462
200 - 225	667	462
250 - 300	876	462
350	1016	462
400D & 400	1156	462

5.5 Fitting Return Air Ductwork - Model STE

Return air (inlet) ducting may be attached to the blower cabinet. The rear of the standard blower cabinet is totally open. The cabinet is available with a smaller inlet opening with a spigot.

Heater Size	Standard Blower Cabinet		Optional Blower Cabinet	
	Width	Height	Width	Height
100 - 125	451	706	451	495
150 - 175	591	706	591	495
200 - 225	730	783	730	495
250 - 300	940	783	940	495
350	1080	783	1080	495
400D & 400	1219	783	1219	495

6.0 COMMISSIONING AND TESTING

The commissioning and testing should only be carried out by a competent person. This section should be read completely and fully understood. A commissioning service is available from AMBI-RAD.

6.1 Electrical Check

After completion of the installation and before switching on the electrical supply, a preliminary check must be performed by a qualified electrician. Check the following:

- Check that all site wiring is connected in accordance with the appropriate circuit diagram in Section 9.
- Ascertain that the correct fuse and cable size are fitted.
- Check that the earthing of the heater has been carried out by conducting an earth continuity test. Connect a test meter, one lead to the appliance earth point and the other lead to the main incoming earth at the isolator. A resistance reading of 0.1 ohm or less must be indicated. If a higher reading is obtained, check earth connections for being clean and tight. If problem still exists, seek expert advice.
- Carry out a polarity test. Connect one lead of a suitable AC voltmeter to earth and connect the other lead to the live supply terminal at the heater. Turn on power to the heater and check for proper voltage.

The same result should be obtained by connecting the test leads from live to neutral.

Connect the voltmeter test leads to N and E. A reading of between 0-15 volts at maximum should be obtained. If these tests do not conform to the above, there is a fault which must be rectified before progressing further with the commission.

- Check that a suitable thermostat or control panel has been fitted.
- Ensure that an isolation switch has been fitted.
- Centrifugal Fan Models -- Check belt tension; see Section 6.7.5.. Check blower rotation; see Section 6.7.6. After heater is in operation, verify that the amp draw does not exceed maximum allowed on motor data plate.

6.2 Gas Connection

The whole of the gas installation, including the meter, should be inspected, tested for soundness, and purged in accordance with BS6891 and British Gas Document IGE/UP/1.

6.3 Suspension and Support

Check to ensure that the heater is adequately suspended or supported and that no other parts have been fitted that are not properly supported or secured. For safe heater operation, check that the heater is level in all directions.

6.4 Lighting the Heater

All heaters are fitted with an automatic spark ignition system. When sufficient air flow is proven by the air proving switch and a pre-purge period elapses, the built-in ignitor and multifunctional control valve operate. The ignition spark ignites the gas creating the pilot flame which is detected by the flame rod. If a pilot flame is not detected within 50 seconds, the ignition controller locks out and must be manually reset. (See Figure 9.)

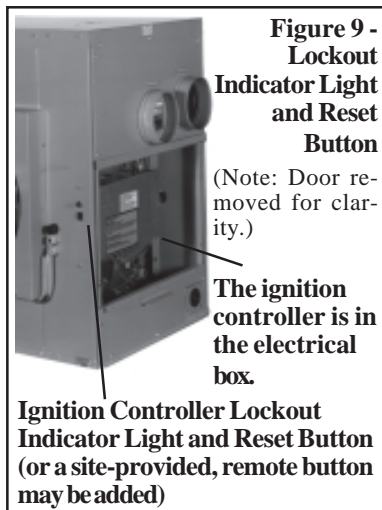

NOTE: If the first reset is not successful, wait 15 seconds before resetting the ignitor.

6.4.1 To Turn the Heater "On"

The following checks should be carried out before attempting to light the heater.

- Ensure that the electrical supply and the gas supply to the heater are turned "On"
- If fitted with a clock control, set to "On".
- Set the room temperature control to above the ambient temperature. The main burners will light. (The main burners can be seen through the viewing port).
- Adjust the room temperature control to the required operating temperature. The heater will operate automatically.

NOTES: If heater will not "start" on initial start up, the ignition controller may be in lockout position. Depress the reset button. Several attempts at lighting the pilot may be required to remove the air from the multifunction valve.

6.4.2 To Turn the Heater "OFF" for Short Periods

Adjust the room temperature control to its lowest temperature or "Off". The fan will continue to run to cool the heat exchanger before turning off automatically.

6.4.3 To Turn the Heater "OFF" for Long Periods

Adjust the room temperature control to its lowest temperature or "off". When the fan has stopped, turn "off" the gas and the electricity supplies.

6.5 Heater Pipework

The soundness of the heater's pipework has been checked at the factory. However, during shipment or installation, connections may be loosened. Check the soundness of the pipework using a leak-detecting fluid such as a soap and water solution. If any leaks are found, they must be rectified immediately.

WARNING: Never use a naked flame for checking the soundness of any gas connections.

6.6 Adjustments

6.6.1 Burner Gas Adjustment

The gas pressure is set for the required heat input before the heater leaves the factory, and normally the gas pressure will not require re-setting. To check gas pressure, the following procedure should be carried out.

- 1) Ascertain from Section 1, Technical Data (Table 3 or 4), the correct burner pressure for the heater.
- 2) Turn the room temperature control to its lowest setting.
- 3) Remove the screw from the outlet pressure test point of the gas valve (See Figure 10, page 12). Connect a manometer to the test point.
- 4) Adjust the room temperature control to a setting above ambient temperature.
- 5) Observe the gas pressure on the manometer and compare to required burner pressure.
- 6) If necessary, adjust the burner gas pressure. Remove the cover screws. Turn the regulator screw anti-clockwise to decrease the pressure or clockwise to increase the pressure.
- 7) Set the room temperature control to lowest setting to turn off the main burners. Replace the pressure test point screw and cover screw (if removed) and with the main burner turned on, test for gas soundness using a leak-detection fluid such as a soap and water solution.

Reset temperature control to required operating temperature.

6.0 COMMISSIONING AND TESTING (cont'd)

6.6.1 Burner Gas Adjustment (cont'd)

Figure 10 - Multifunctional Control Valve - Standard Valve Used on Sizes 100-400

(NOTE: When measuring gas pressure, do not remove screw. Loosen enough to allow gas pressure to register.)

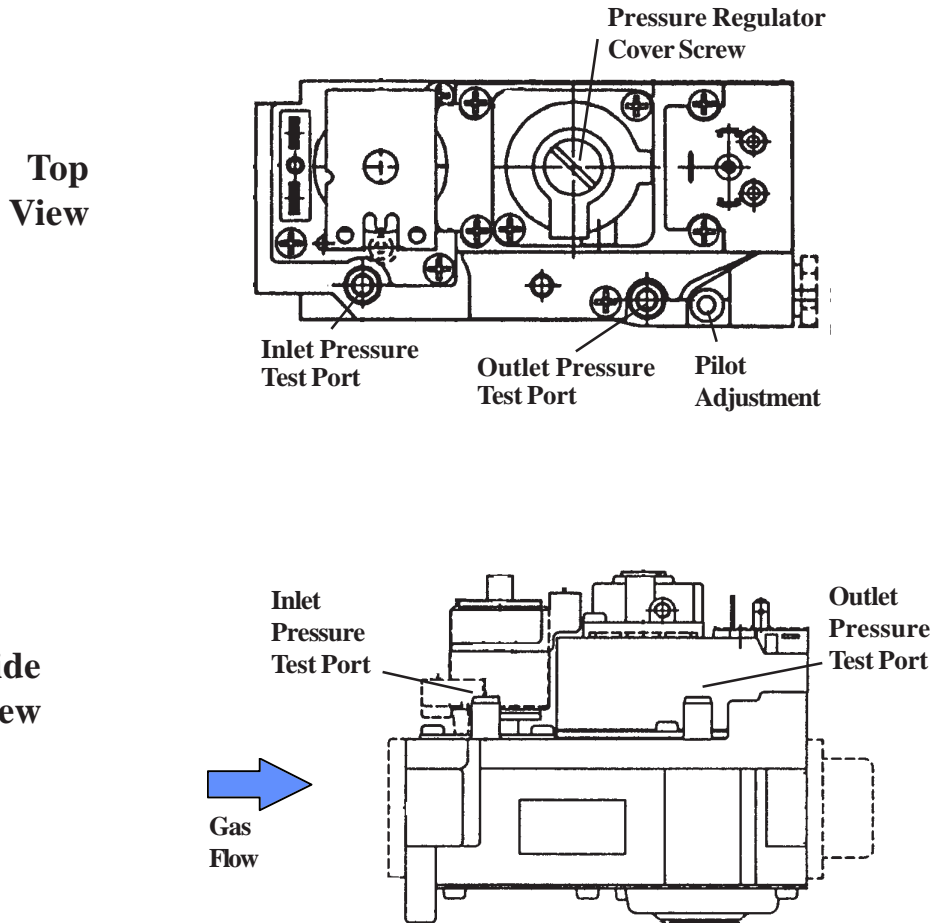

6.6.2 Pilot Flame Adjustment

The pilot regulating screw is contained in the multifunctional control valve. The pilot regulating screw is factory set for the maximum pilot rate. If the G20 natural gas inlet pressure to the heater exceeds 25 mbar (10 inches W.G.), the pilot rate should be reduced.

Figure 11 - Pilot Flame Adjustment

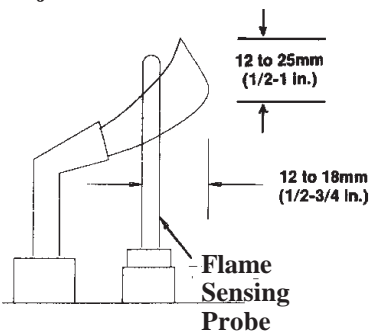

Pilot Flame Adjustment Instructions

- 1) Remove the cover screw (see Figure 10).
- 2) To adjust the pilot flame, turn the adjusting screw clockwise to reduce the flow.
- 3) Replace the cover screw after pilot adjustment is completed.

6.6.3 Burner Air Shutter - G31 Propane Gas Only

A slotted screw on the end of the manifold bracket moves the air shutter and adjusts all burners simultaneously. If necessary, adjust shutter after the heater has been in operation for 15 minutes. Close shutters (turn screw anti-clockwise) until flame turns yellow. Open shutters (turn screw clockwise) until yellow disappears.

DANGER: Failure to adjust air shutter properly could cause property damage, injury, and/or death.

6.7 Air Distribution System

6.7.1 General Requirements

The system should be checked to ensure that the installation work has been carried out in accordance with the design requirements.

6.7.2 Free Blowing Heaters

Adjust the discharge louvres to provide a satisfactory spread of heated air. Direct the heated air to the floor avoiding direct draught on personnel who may be working nearby.

CAUTION: To avoid getting burned, adjust louvres prior to heater operation. If louvres need re-adjusting after startup, wear protective gloves.

The free blowing heater is equipped with a motor with thermal overload protection of the automatic reset type. Should the motor refuse to run, it may be because of improper current characteristics. Make certain that the correct voltage is available at the motor.

6.7.3 Ducted Heaters - Model STB or Model STE

Heaters with a centrifugal blower for air delivery are limited to a maximum external pressure of 500 Pa (2.0 inches W.G.) and a temperature rise of 42°C.

Most motors are equipped with thermal overload protection of the automatic reset type. If a motor is not equipped with thermal overload protection, the unit will be equipped with a starter. The adjustable setting on the starter will be factory set to match the amp draw of the motor and sealed. No change should be made to starter set unless the original motor is replaced.

Starters are supplied from the factory for manual reset operation. If an overload condition is experienced, the condition must be corrected, and the starter must be manually reset.

After the installation is complete including all ductwork, check the amp draw of the motor with an amp meter to verify that the motor amp rating on the motor data plate is not being exceeded. Amps may be adjusted downward by reducing blower speed or by increasing the duct system static pressure. The temperature rise must be within the range specified on the unit rating plate.

6.7.4 Adjusting Centrifugal Fan (Blower) Speed

The blower speed may be adjusted to achieve the desired outlet temperature, as long as the adjustment is within the temperature rise and the static pressure limits shown on the heater rating plate. Motors are factory set between maximum and minimum blower speeds.

If the duct resistance is low, the blower may deliver too high an air volume. If the resistance is very low, the blower may deliver excess air to overload the motor, causing the overload protector to cycle the motor. Reducing the blower speed will correct these conditions. If ductwork is added to an installation, it may be necessary to increase the blower speed. Decreasing blower speed will increase outlet temperature; increasing blower speed will decrease outlet temperature.

The belt drive on these units is equipped with an adjustable pulley which permits adjustment of the blower speed. Follow these instructions to adjust the blower speed.

1. Turn off the gas and the electric power.
2. Loosen belt tension and remove the belt.
3. Loosen the set screw on the side of the pulley away from the motor.
4. **To increase the blower speed, decreasing outlet temperature**, turn the adjustable half of the pulley inward. **To decrease the blower speed, increasing the outlet temperature**, turn the adjustable half of the pulley outward. One turn of the pulley will change the speed 8-10%.
5. Tighten the set screw on the flat portion of the pulley shaft.
6. Replace the belt and adjust the belt tension. Adjust tension by turning the adjusting screw on the motor base until the belt can be depressed 19mm. (See Figure 16, page 16.) Re-tighten the lock nut on the adjusting screw.
7. Turn on the gas and electric. Light the heater following the instructions on the lighting instruction plate.

8. Check the motor amps with an amp meter. The maximum motor amp rating on the motor nameplate must not be exceeded.

When service is complete, carry out commissioning procedure, Section 6.0-6.8.

6.7.5 Check Belt Tension

Check the belt for proper tension. Proper belt tension is important to the long life of the belt and motor. A loose belt will cause wear and slippage. Too much tension will cause excessive motor and blower bearing wear. Adjust the belt tension by turning the adjusting screw on the motor base until the belt can be depressed 19 mm. (See Figure 16, page 16.) After correct tension is achieved, re-tighten the locknut on the adjusting screw.

6.7.6 Blower Rotation

Each blower housing is marked for proper rotation. Rotation may be changed on single-phase motors by re-wiring in the motor terminal box. Three-phase motors may be reversed by interchanging two wires on the 3-phase supply connections.

6.8 Heater Controls

6.8.1 Standard Heater Controls

Check heater operation after all adjustments have been carried out. Set the room temperature control to above ambient temperature.

These power vented heaters are equipped with a pressure-sensitive, combustion air safety switch that monitors airflow. The switch is a single-pole, double-throw switch that operates with the following settings (settings are for sea level installation).

Sizes	100	125	150	175	200	225	250	300	350	400D	400
mbar	1.18	1.18	1.18	1.45	1.08	1.45	1.18	1.45	1.18	1.18	1.45
inches w.g.	0.47	0.47	0.47	0.58	0.42	0.58	0.47	0.58	0.47	0.47	0.58

When the combustion air safety switch closes verifying airflow, the pilot will be lighted and the multifunctional control valve will open.

The main burner will light. Within approximately 30 seconds, the time delay relay will activate the fan thermostat control which will energize the fan or blower motor.

Continue to operate the heater for several minutes to ensure the limit switch does not activate. The limit switch is a manually reset switch which must be cooled to room temperature before being reset. The reset button is accessible by opening the heater control panel. (Refer to Figure 18A.) If for any reason, the limit switch trips, the cause must be determined. See Fault Finding Chart, Section 10.3.

Turn the room temperature control to its lowest setting. The main burners should extinguish while the fan or blower continues to cool the heat exchanger. When the heat exchanger is sufficiently cooled (usually within five minutes), the fan control will de-energize the fan or blower motor.

The circuit diagram on the heater indicates the type of gas control.

6.8.2 Heater with Optional Two-Stage Gas Control

Checks and operation sequence are the same as in Section 6.8.1, except that the heater is controlled by a two-stage temperature controller and a two-stage valve (50% and 100%). Depending on the temperature control setting, the gas valve fires the burner at either 50% or 100%.

6.8.3 Heater Controls with Optional Electronic Modulation Gas Control

Checks and operation sequence are the same as in Section 6.8.1, except that the gas valve is electrically controlled to modulate between 50% to 100% firing rate depending on the temperature requirement.

6.0 COMMISSIONING AND TESTING (cont'd)

6.9 Handing Over

Upon the satisfactory completion of commissioning and testing, hand the instructions to the user or purchaser. Advise the user/purchaser how to safely use and operate the heater, including all associated equipment and controls. Ensure that the user/purchaser understands how to start the heater and how to turn it off.

Suggest that the instructions be placed close to the heater for future reference. Instruct the user/purchaser not to place the instructions adjacent to a hot surface or in a place where they may restrict air flow.

Advise the user/purchaser that for safe and efficient operation, the heater must be serviced at least annually. A complete after sales service is available from AMBI-RAD.

7.0 SERVICING INSTRUCTIONS

WARNING: Only competent and qualified engineers should carry out servicing and fault finding on this equipment. Complete after-sale service is available from AMBI-RAD. Before maintenance is carried out, ensure that both gas and electrical supplies are turned off and the appliance is cold.

This heater will operate with a minimum of maintenance. To ensure long life, satisfactory performance and continued safety, a heater that is operated under normal conditions should be inspected and cleaned annually. Heaters that are operated in areas where an unusual amount of dust or impurities are present in the air, require more frequent maintenance.

7.1 Servicing Requirements/Procedure

The following procedures should be carried out at least annually:

1. Remove the Burner Assembly as in Section 8.1.
 - a) Check the condition of the pilot burner and clean off any deposits which may have formed. Clean the inside of the burner hood with an emery cloth. Clean the pilot injector with solvent and compressed air. **CAUTION: Wearing eye protection is recommended.**
Check the condition of the flame rod and clean with an emery cloth. Remove all deposits. Check the spark gap (2.5 mm).
 - b) Clean any deposits from the main burner, paying particular attention to lint or fluff, etc., which may have formed around the injectors in the venturi of the burner. Clean using compressed air and a soft brush. **CAUTION: Wearing eye protection is recommended.**
 - c) Clean any deposits from the burner tray.
2. The heat exchanger should remain clean unless some problem has developed with combustion. Examine the heat exchanger internally and externally for any sign of deterioration.
3. **Model STA** — The fan blade, fan guard and motor should be cleaned to remove any buildup of dust, fluff, etc.

Model STB — The blower, belt guard, inlet guard and motor should be cleaned to remove any buildup of dust or fluff. The blower belt should be checked for tension and wear. Worn belts should be replaced (See Section 8.6).

Model STE — The blower and motor should be cleaned to remove any buildup of dust or fluff. The blower belt should be checked for tension and wear. Worn belts should be replaced (See Section 8.6).

4. Ensure that any purpose provided air vents for ventilation and combustion are free from obstruction.
5. The flue/air inlet system should be checked for soundness. Reseal/replace any parts that do not appear sound.
6. Check the wiring for any signs of damage. Replace wiring with an equivalent specification.
7. Check operation of the fan control and the fan control relay.
8. When service is complete, carry out commissioning procedure, Section 6.0-6.8.

8.0 REMOVAL AND REPLACEMENT OF PARTS

WARNING: To comply with legislation, only certificated spares may be fitted to heaters supplied after 1/1/96. A full spares service is provided by AMBI-RAD. Only a competent and qualified engineer should carry out servicing on this equipment. Before maintenance is carried out, ensure that both gas and electrical supplies are turned off and the appliance is cold. After maintenance work, the heater **MUST** be fully commissioned (See Section 6).

8.1 Main Burner Removal

Instructions for Burner rack Removal (Refer to Figures 12-13):

1. Open the control access door and remove the bottom side panel from the heater. Open the electrical box cover.
2. Disconnect the ignitor lead from the ignition controller (See Figure 19). Disconnect the flame sensor lead (wire from the ignition controller to the probe) from the auxiliary flame probe.
3. Mark and disconnect electric valve leads.
4. Uncouple the union in the gas supply line upstream from the valve.
5. Remove the two screws holding the bottom of the burner rack assembly. Slide the "drawer-type" burner rack out of the heater.

Figure 12A - Burner Rack Removal

Step 1 - Open the Centre Door and Remove the Burner Access (lower) Panel



Steps 2, 3, and 4 - Disconnect as described above.
Step 5 - After disconnecting everything, remove the two screws and slide the burner rack out of the heater.

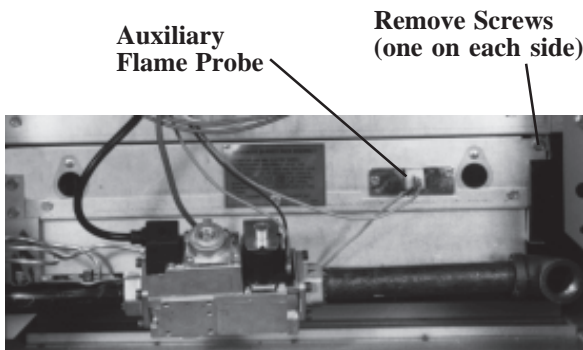

Uncouple gas line (gas valve illustrated may not be the same as on the heater)

Instructions to remove the individual burners from the burner rack assembly :

1. With the burner assembly upside down, remove the screws (located at the rear) that secure the retaining bracket.
2. Lift the front of the burner upwards slightly and pull it back, removing the individual burner (a slight tap with a wooden mallet is sufficient to dislodge it).
3. Clean individual burners using air pressure or soft brush Use an air nozzle to blow out scale and dust accumulation from the burner ports. **CAUTION: Wearing eye protection is recommended.** Alternately blow through burner ports and venturi. Use fine wire to dislodge any stubborn particles. Do not use anything that might change the port size.

Figure 13 - Individual Burner



Instructions to Re-Assemble

1. Reverse the Steps to disassemble and remove the burner rack.
2. When lighting, always follow the lighting instructions on the heater. After any service work, the heater must be fully commissioned. See Section 6.0-6.8.

NOTE: Use only factory-authorized replacement parts. Heaters supplied after 1/1/96 must use certificated spares to comply with legislation.

A complete spares service is available from AMBI-RAD.

8.2 Pilot Burner Injector

1. If connected, disconnect the pilot tubing from the pilot burner.
2. Fit a new pilot burner injector.
3. Re-assemble in reverse order.

Figure 12B - Burner Rack Removed

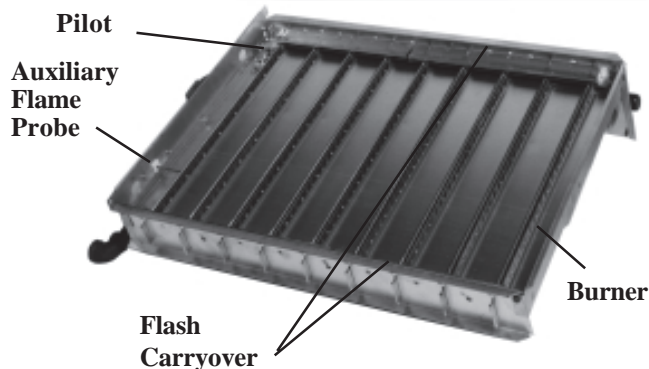
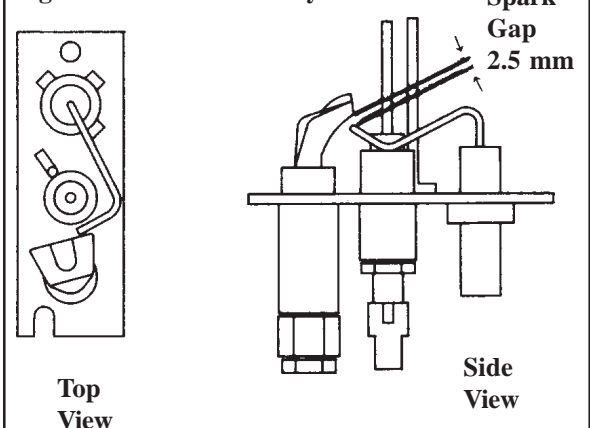

Figure 14 - Pilot Assembly



8.0 REMOVAL AND REPLACEMENT OF PARTS (cont'd)

8.3 Pilot Burner Assembly

1. To remove the pilot assembly, remove its two fixing screws.
2. Refit the new pilot burner by re-assembling in reverse order.
3. Check relationship of the pilot burner with the adjacent main burner.
Refer to Figure 15.

Figure 15 - Relationship of Pilot Assembly and Main Burner

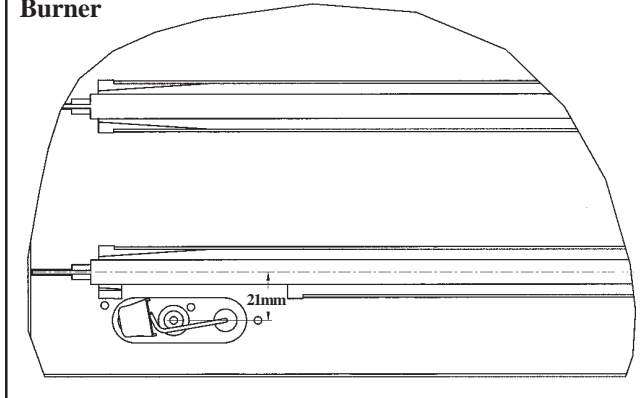

8.4 Pilot Ignition System

The ignition controller of the intermittent electronic ignition pilot system is located in the electrical box (See Figure 19). There are no field-replaceable components in the ignition controller. Check the lead wires for insulation deterioration and good connections.

Proper operation of the electronic spark ignition system requires a minimum flame signal of 0.7 micro amps as measured by a micro amp meter.

CAUTION: Due to high voltage on pilot spark wire and pilot electrode, do not touch when energized.

8.5 Main Burner Injectors

1. Remove the burner rack (See Paragraph 8.1).
2. Remove the manifold bracket screws and manifold
3. Unscrew the main burner injectors .
4. Re-fit new injectors
5. Re-assemble in reverse order.

8.6 Blower Motor and Belt

8.6.1 Belt Tension

Check belt tension. Belt should depress approximately 19mm. See Figure 16.

Figure 16 - Belt Tension

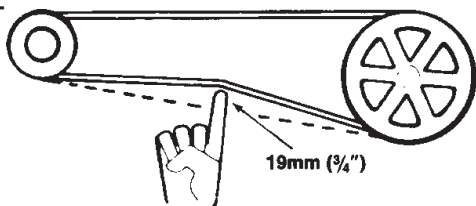

Adjust belt tension by means of the adjusting screw on the motor mounting plate.

When belt is adjusted properly, tighten the lock on the adjusting screw.

8.6.2 Blower Motor

Check motor amps with an ammeter. The maximum motor amp rating on the motor badge must not be exceeded.

CAUTION: A ducting system having excessive static pressure may cause the limit control to actuate.

8.7 Replacement of Fan Motor and/or Blade

Follow these instructions for removal and replacement of fan motor and/or fan blade.

1. Turn off the gas supply.
2. Disconnect the electrical power to the heater.
3. Disconnect the fan motor wires and push out the cable retaining gland.
4. To remove the subassembly including the fan motor, the blades, and the fan guard, remove the screws that attach the fan guard to the heater.
5. Either the fan motor, fan blade or both may now be replaced. Space the fan blade on the shaft as shown in Figure 17.
6. Re-assemble in reverse order.

Figure 17 - Correct Spacing of the Fan Blade on the Motor Shaft

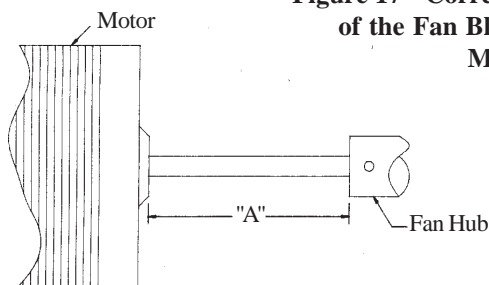

Heater Size	"A" -- Hub to Motor Spacing
100	65 mm
125	52 mm
150, 175, 200, 225	65 mm
250, 300	52 mm
350, 400D, 400	65 mm

8.8 Multifunctional Control Valve

1. Ensure the electrical supply is isolated.
2. Remove the pilot supply tube and the spark tension lead.
3. Remove the terminal cover and disconnect the electricity connections.
4. Disconnect the union between the multifunctional control valve and the gas service cock. Remove the valve.
5. Re-fit the replacement valve making all the required connections. If the connection includes an O-ring, fit a new O-ring.
6. Carry out a complete commissioning procedure. Refer to Sections 6.0 to 6.8.

8.9 Limit Controls

The heater is fitted with two manual reset limit controls that interrupt the circuit to the heater operating controls if the temperature setpoint is reached. The primary limit has a capillary tube sensor that measures the air temperature in the heater discharge.

The high limit is a redundant safety device which senses heat exchanger temperature and is set to open at a correspondingly much higher temperature. **A high limit circuit interruption is a major failure caused by a malfunction of the primary safety controls or miswiring. The cause must be determined and corrected; and the fan and primary limit control must be replaced.** When replacing controls, use only factory-authorized replacements.

8.9.1 Location and Instructions for Replacement of Limit Switch with Capillary Sensor (See Figures 18A and 18B)

1. Remove the one-piece heater side panel on the non-control side of the heater.
On the control side of the heater, open the centre door and remove the lower access panel. The limit switch is visible; see Figure 18A.

Figure 18A - Manual Limit Control Switch Location

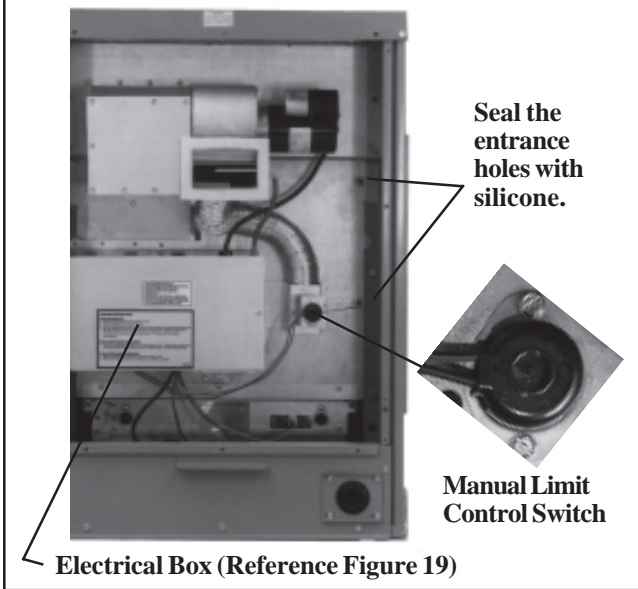

2. Disconnect the limit switch wires from the gas valve.
3. The one-piece capillary tube extends twice across the outlet of the heat exchanger. To replace:
 - a) from the non-control side of the heater (See Figure 18B), pull the upper portion of the "copper-coloured" capillary tube out of stainless steel tube.
 - b) From the control side, withdraw the full length of capillary tubing.
4. Remove the complete limit switch from the bracket by removing the two screws.

5. Replace the limit control switch and re-assemble in reverse order, ensuring that the capillary tube extends two times across the full width of the heat exchanger. **IMPORTANT: To ensure that air does not enter the heat exchanger area, seal all of the capillary tubing entrance holes with silicone.**

Figure 18B - NON-CONTROL Side of the Heater with Cabinet Panel Removed showing the Limit Control Capillary Tubing

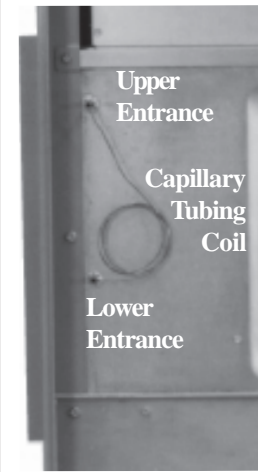

When Removing Tubing: On this side, pull the "copper coloured" capillary tubing from the upper row of stainless steel tubing so that the full length can be pulled through the lower row of tubing and removed from the control side of the heater.

When Installing New Tubing:

- a) Be sure tubing extends twice across full width of the heat exchanger. Coil the excess as shown.
- b) Before replacing the side panel, seal the entrance holes with silicone.

6. Carry out a complete commissioning procedure. Refer to Section 6.0 to 6.8.

8.9.2 High Temperature Limit Switch Location

The high limit switch is located in the electrical box just above the fan temperature control. (See Figure 19). If the high temperature limit switch activates, the primary limit switch and fan control must be replaced. The high limit switch may be reset.

8.10 Fan Temperature Control

The fan temperature control senses the temperature of the heat exchanger. The fan temperature control has a fixed setting and may not be site adjusted. If it is determined that the fan temperature control needs replacing, use only a factory-authorized replacement part. (See Section 8.0.)

The fan control is located in the electrical box (See Figure 19).

As with all service procedures, carry out a complete commissioning procedure after replacement of the fan control. Refer to Sections 6.0 to 6.8.

Figure 19 - Fan Control Location in the Electrical Box (Refer to Figure 18A)

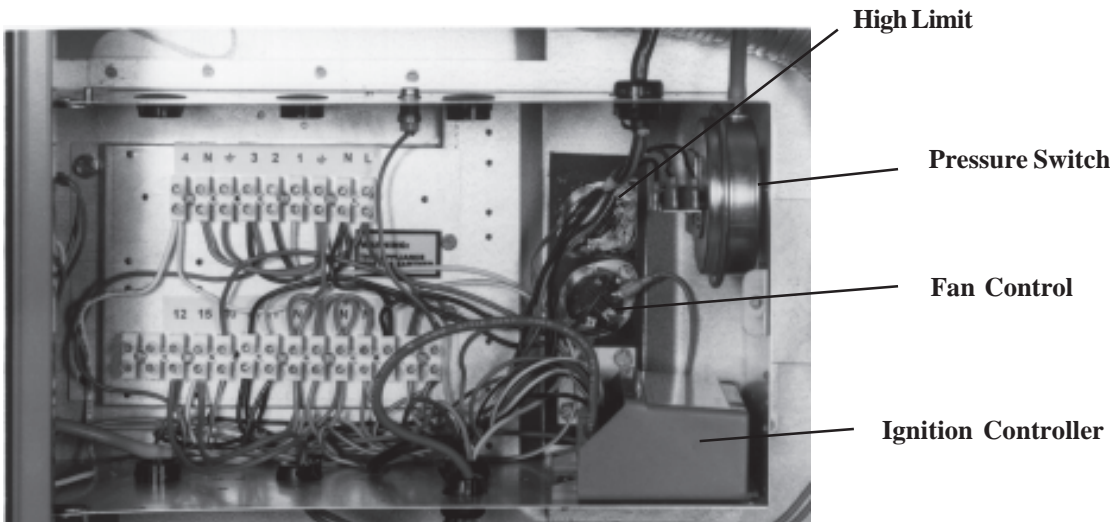

9.0 CIRCUIT DIAGRAMS

9.1 Site Wiring

9.1.1 Site Wiring for Standard Single Stage Control

SITE CONNECTION DIAGRAM
CUSTOMER SUPPLIED WIRING

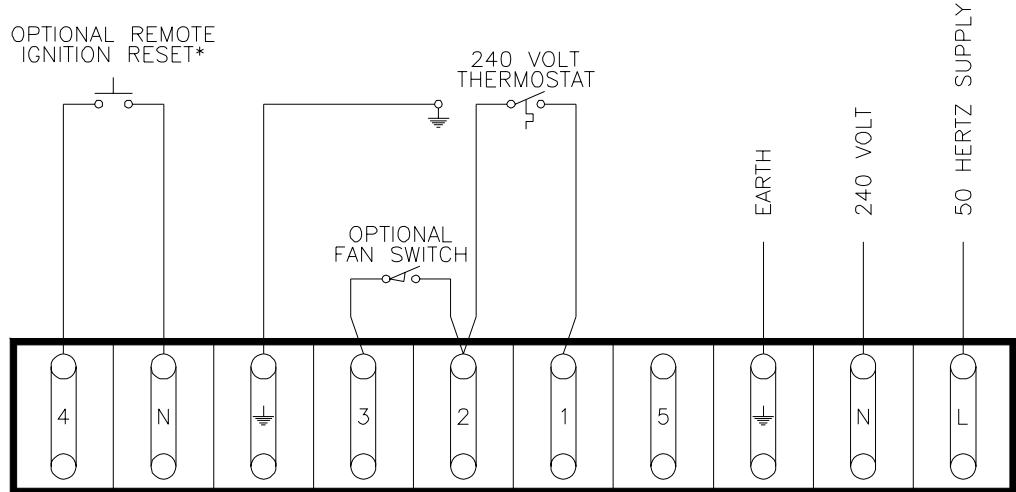

9.1.2 Site Wiring for Optional Two-Stage Control

SITE CONNECTION DIAGRAM
CUSTOMER SUPPLIED WIRING

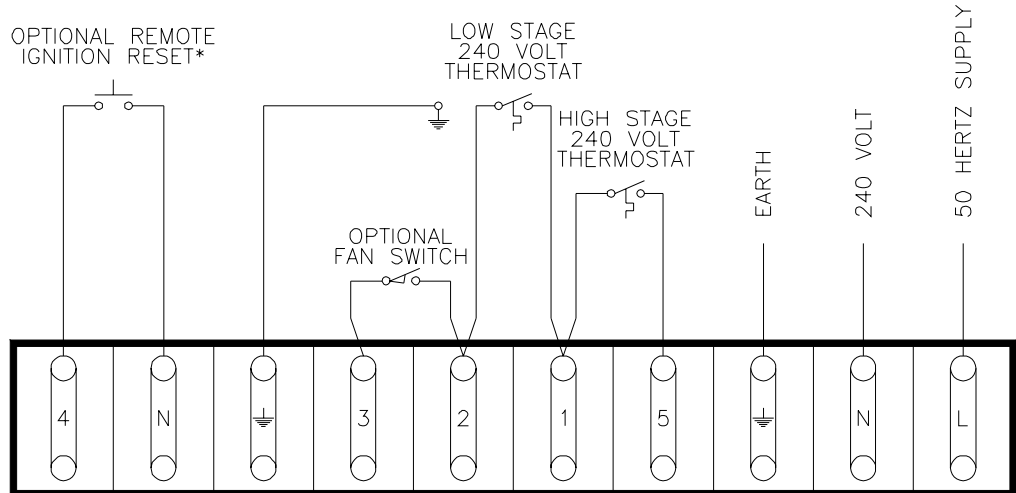

9.1.3 Site Wiring for Optional Electronic Modulation Control

SITE CONNECTION DIAGRAM
CUSTOMER SUPPLIED WIRING

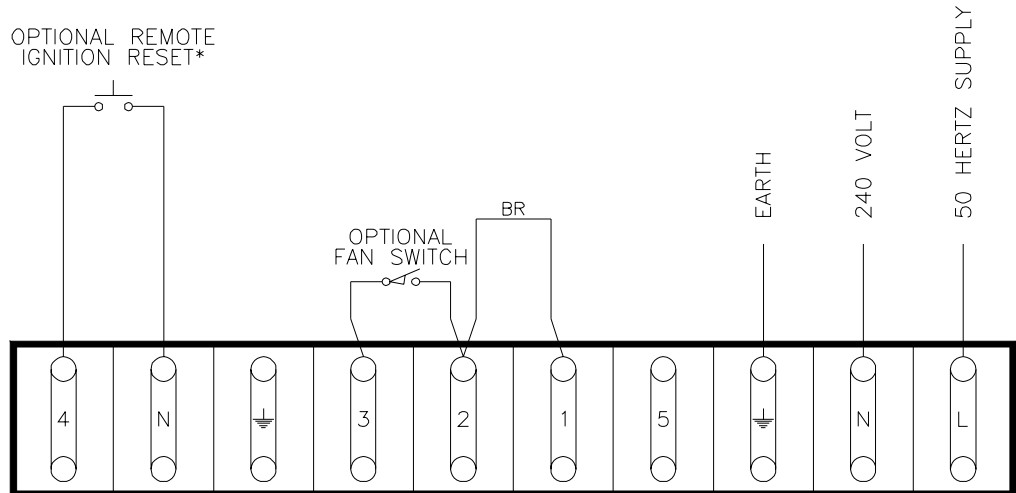

Circuit Diagram A Standard Heater with Axial Fan(s) for Air Delivery

Model STA, Sizes 100 - 175

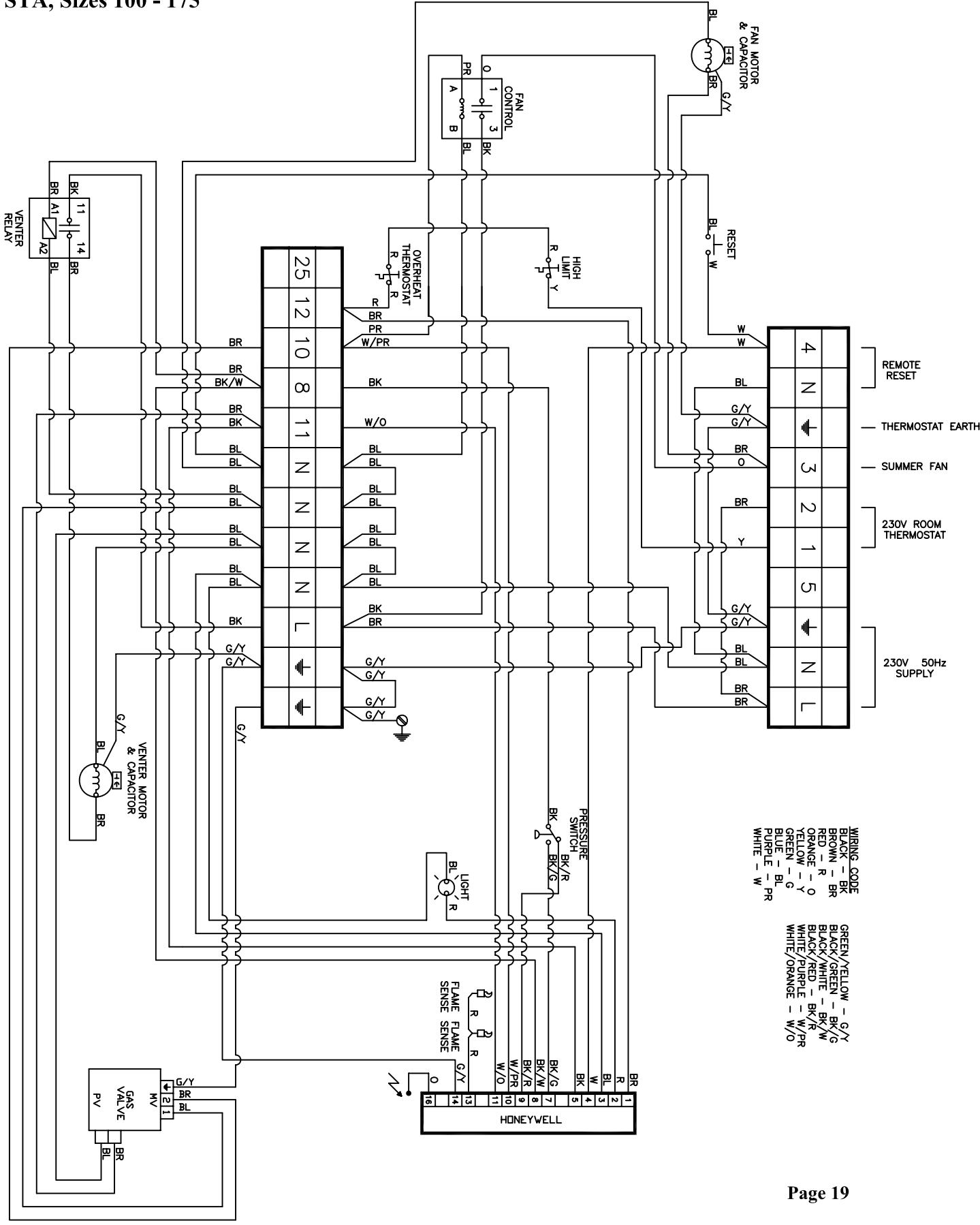

Circuit Diagram C Standard Heater with Axial Fan(s) for Air Delivery

Model STA, Sizes 250-400

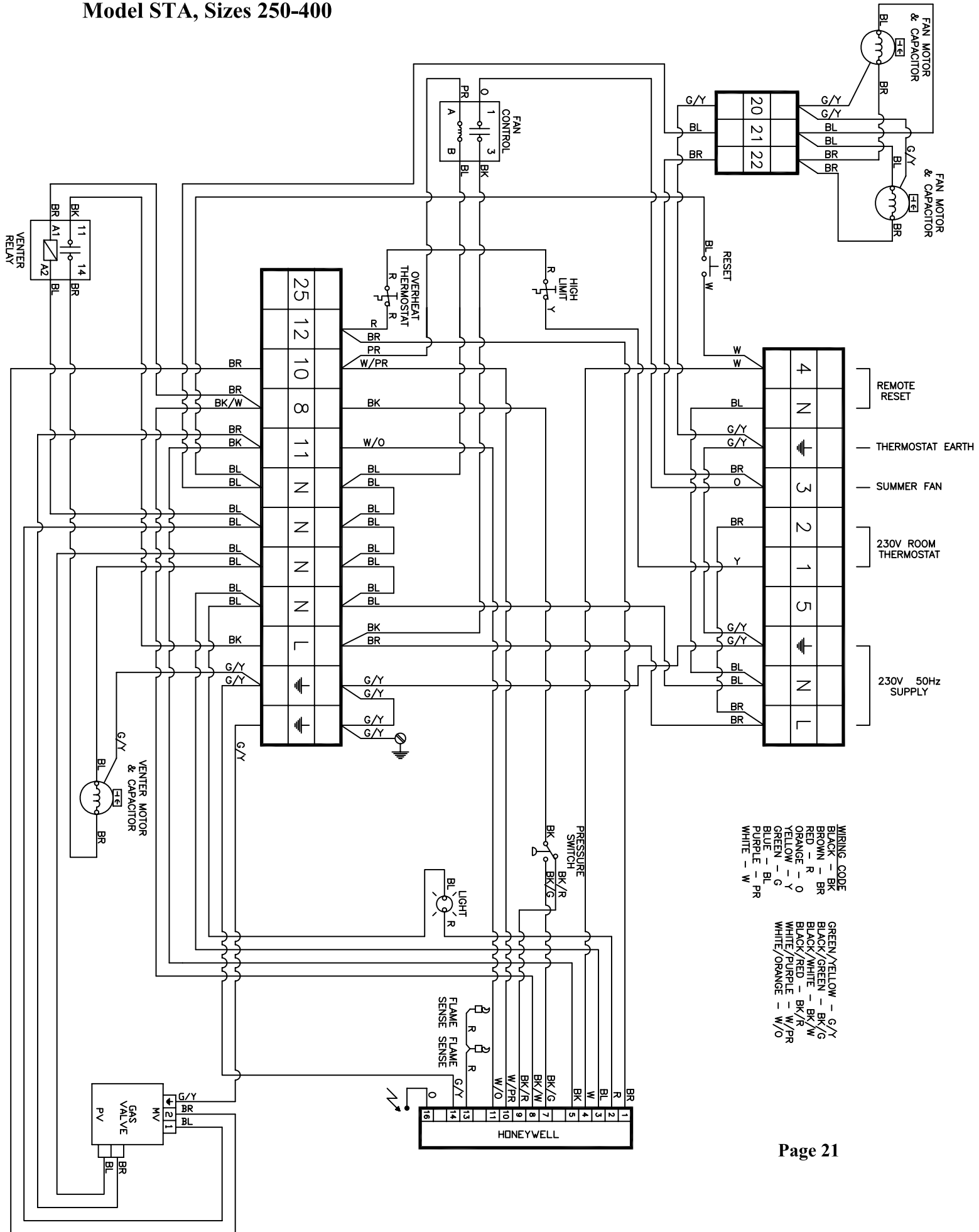

CIRCUIT DIAGRAM D

Circuit Diagram-Standard Heater with a Centrifugal Blower (with or without a cabinet) for Air Delivery

Models STB and STE, sizes 100-175

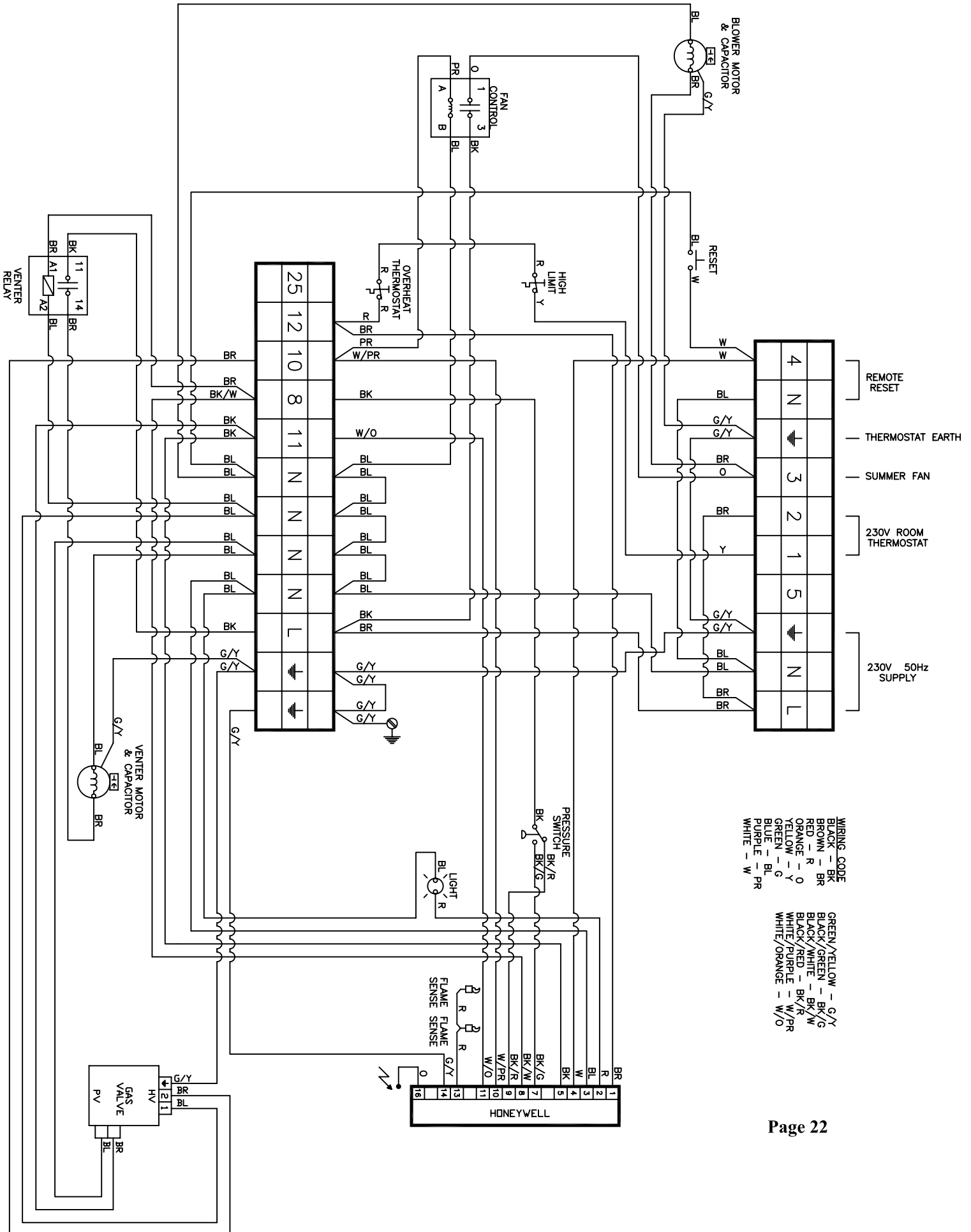

10.0 FAULT FINDING CHARTS

10.1 Main Fault Finding Chart -- Lockout Indicator Light is "Off", but heater will not operate (Applies to heaters with Honeywell controller.)

WARNING: All fault finding should only be carried out by a competent service engineer.

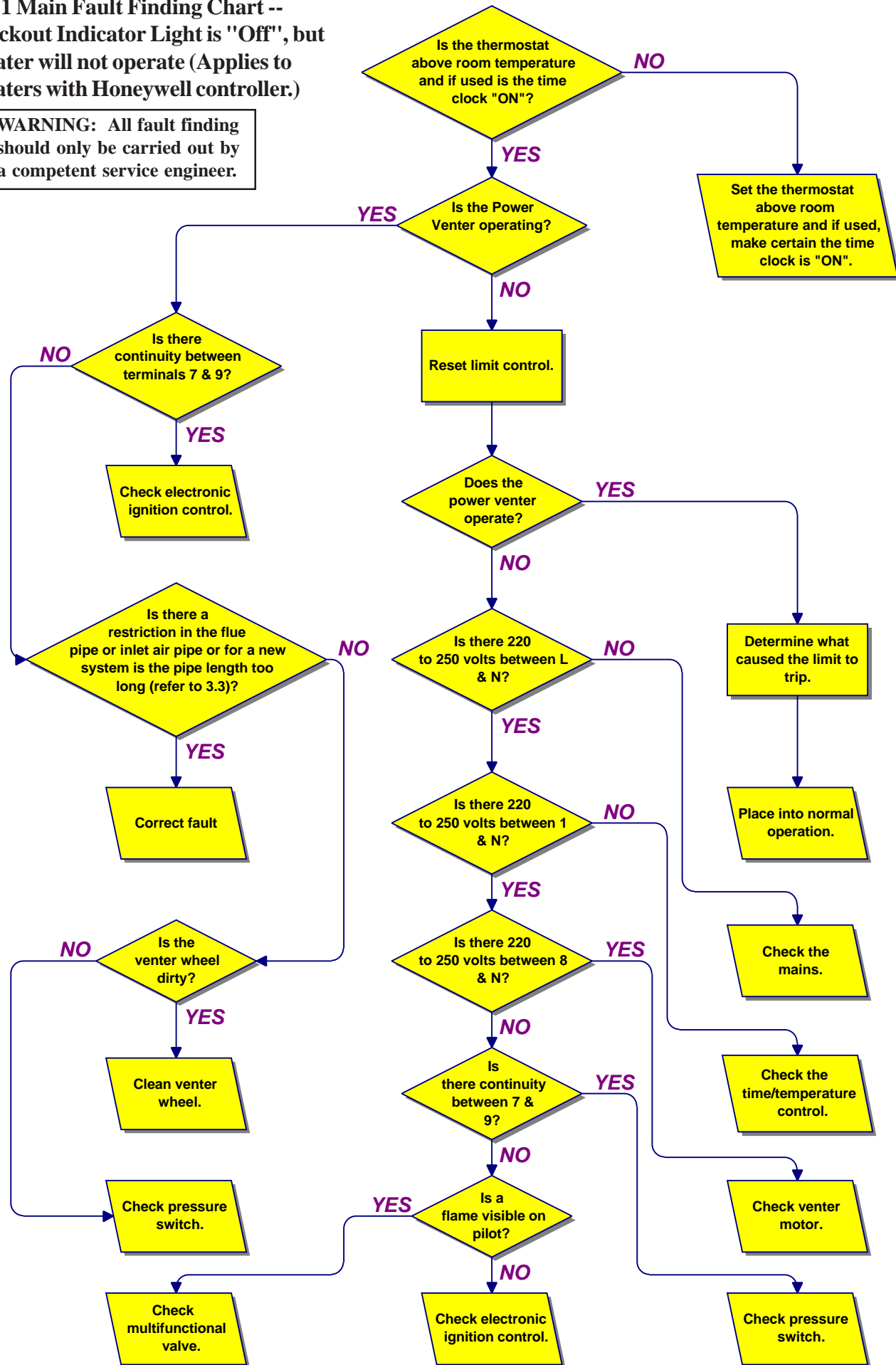

10.2 Ignition Controller Lockout Indicator Light Repeatedly Comes "ON"

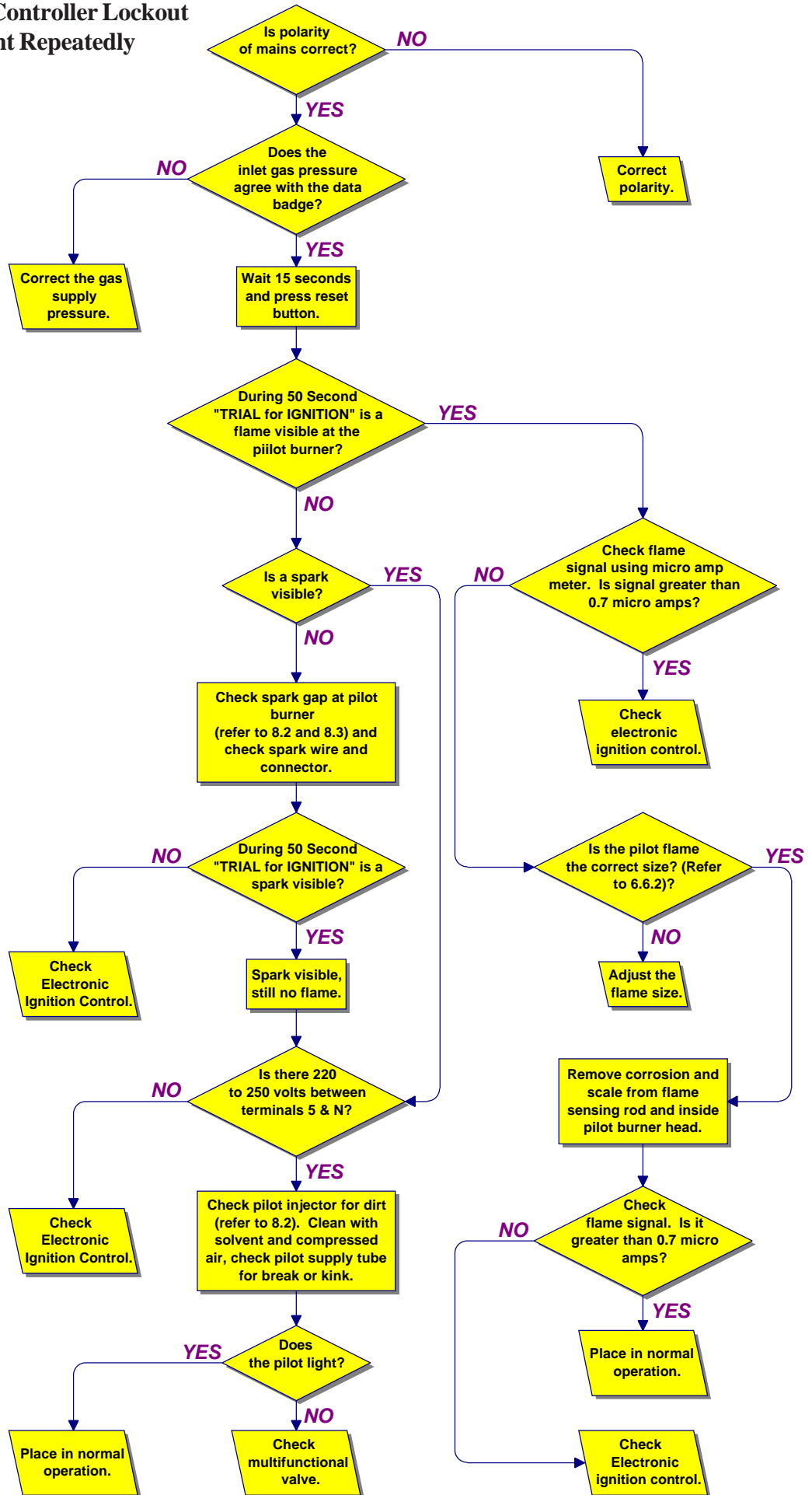

10.0 FAULT FINDING CHARTS (cont'd)

10.3 Limit Control Fault Finding Chart (Limit Control Trips)

NOTE: Interruption of the main electrical supply to the heater when the heater is in operation may cause the limit control to trip. Check that the supply to the heater is not being interrupted incorrectly by (a) Incorrect wiring of the time clock; (b) Fire alarm systems, etc.; or (c) Isolation of main feed to the building.

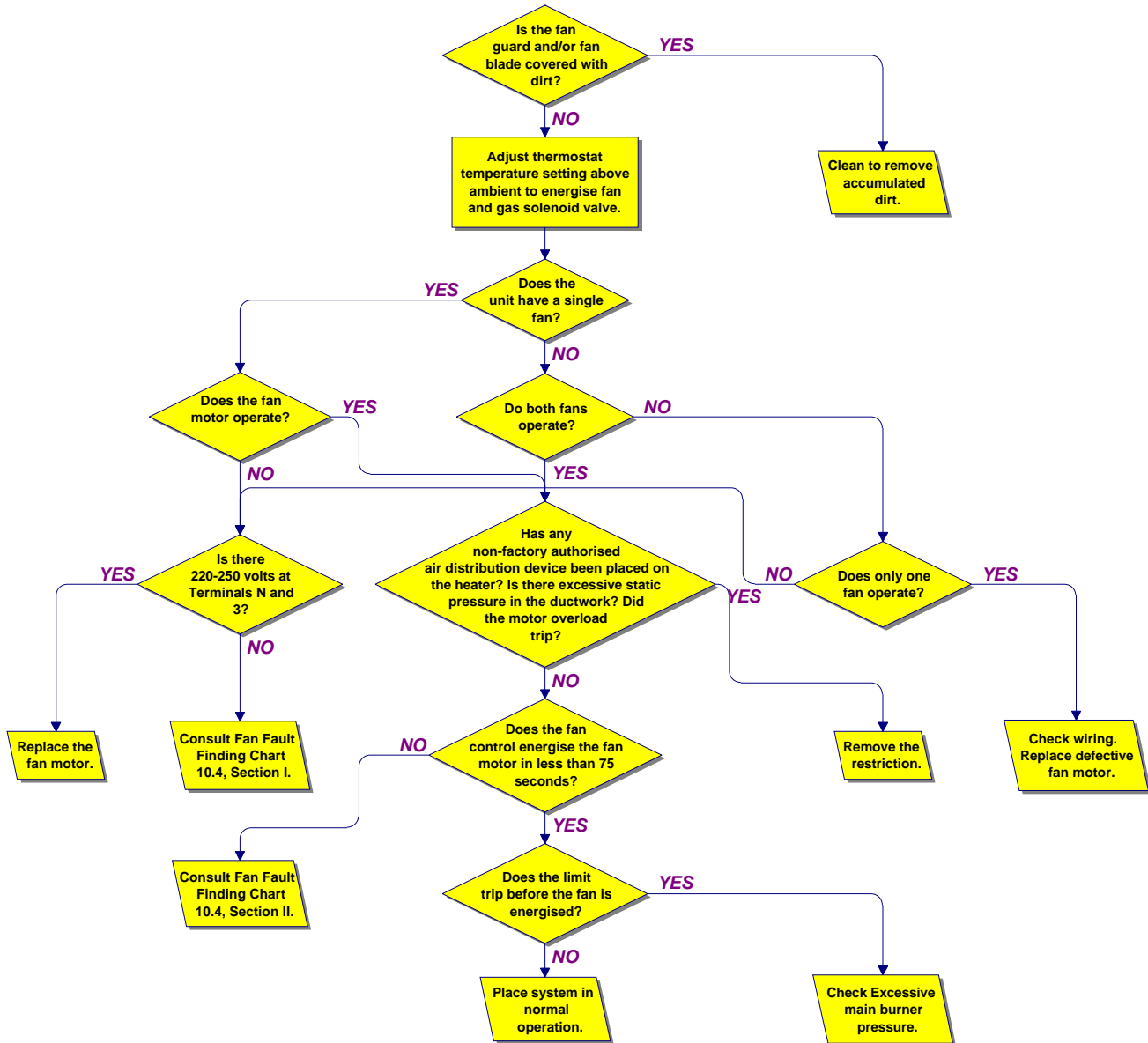

10.4 Fan/Blower Fault Finding Chart

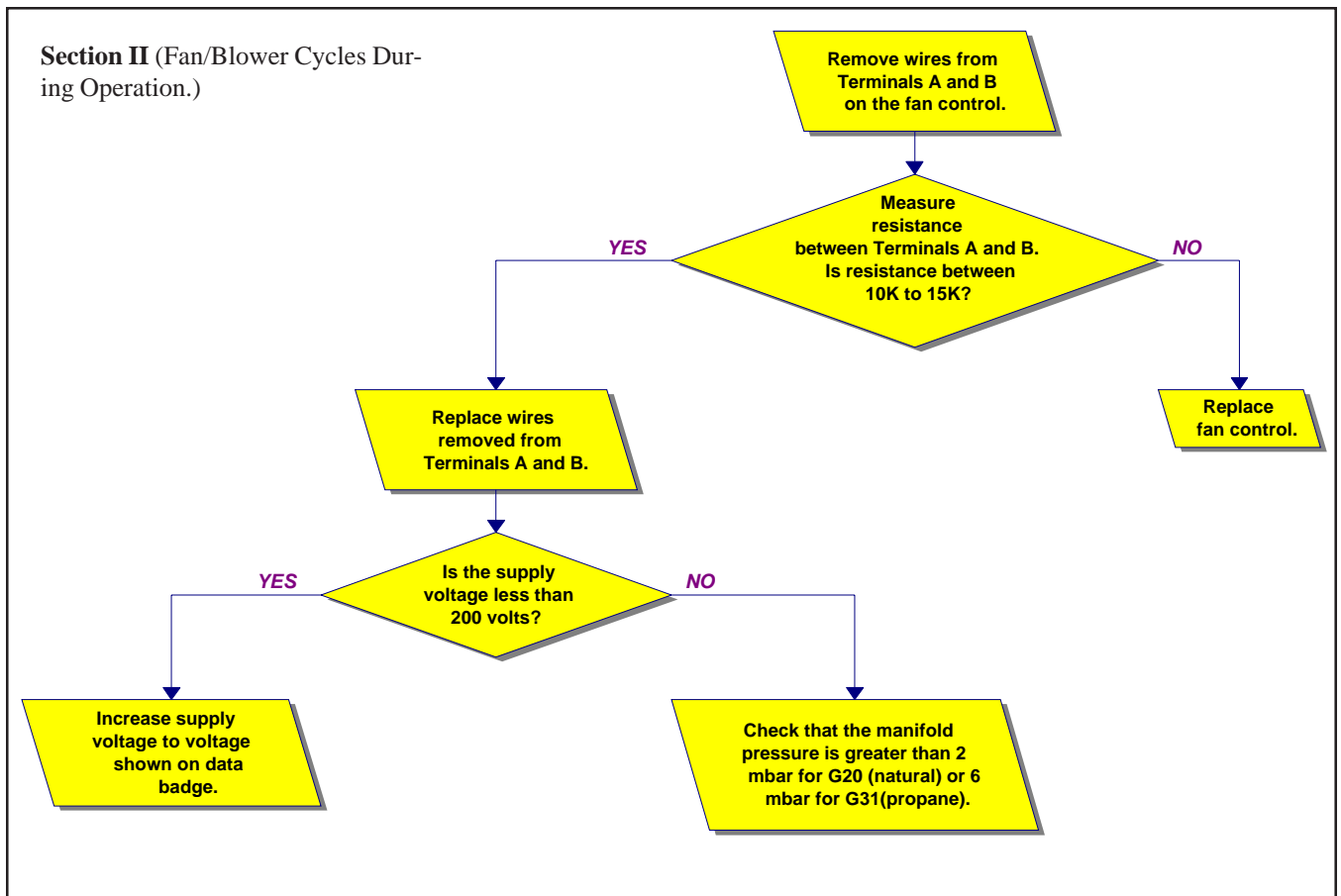
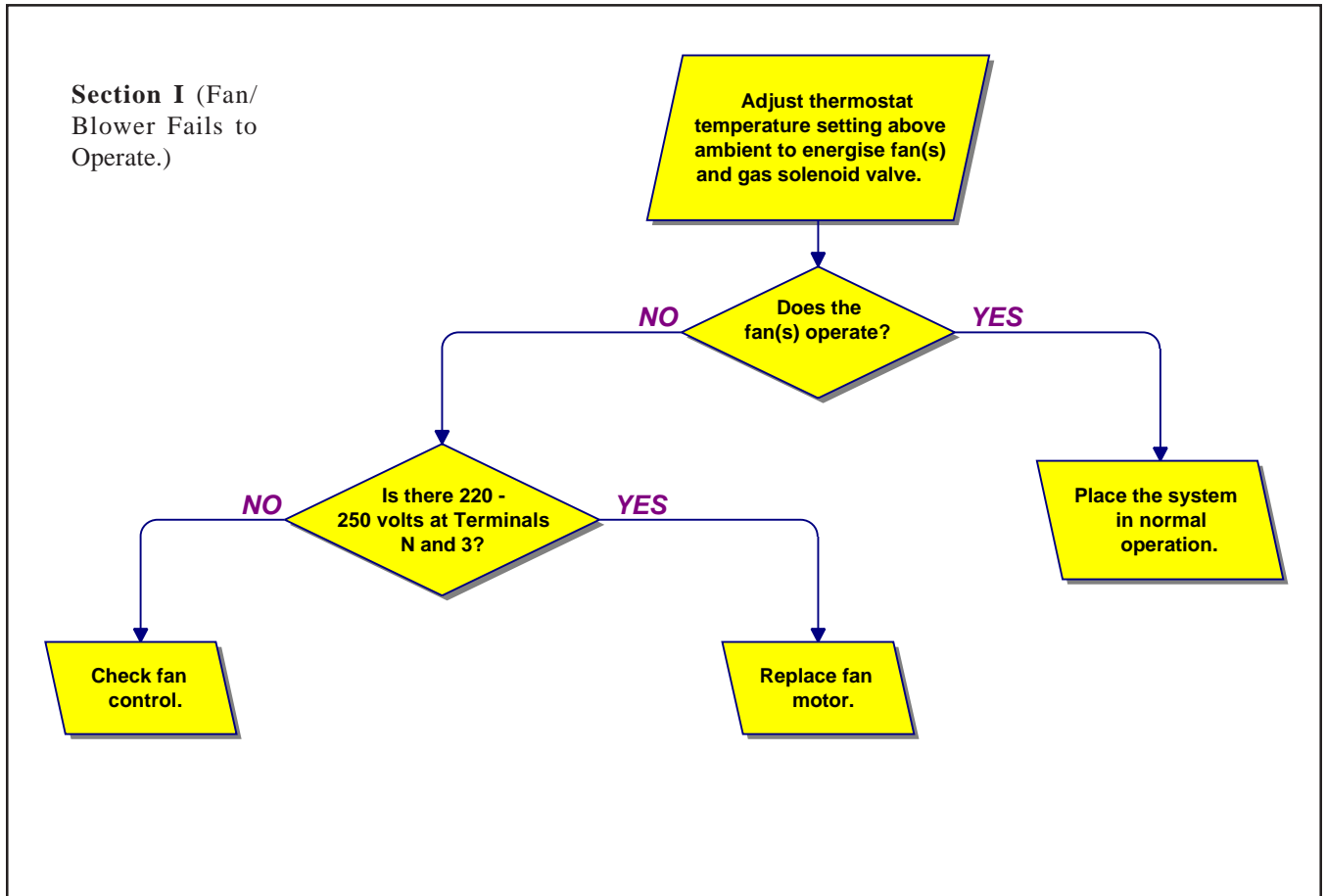

11.0 EXPLODED DIAGRAMS

11.1 Standard Heater Cabinet Parts -- All Models

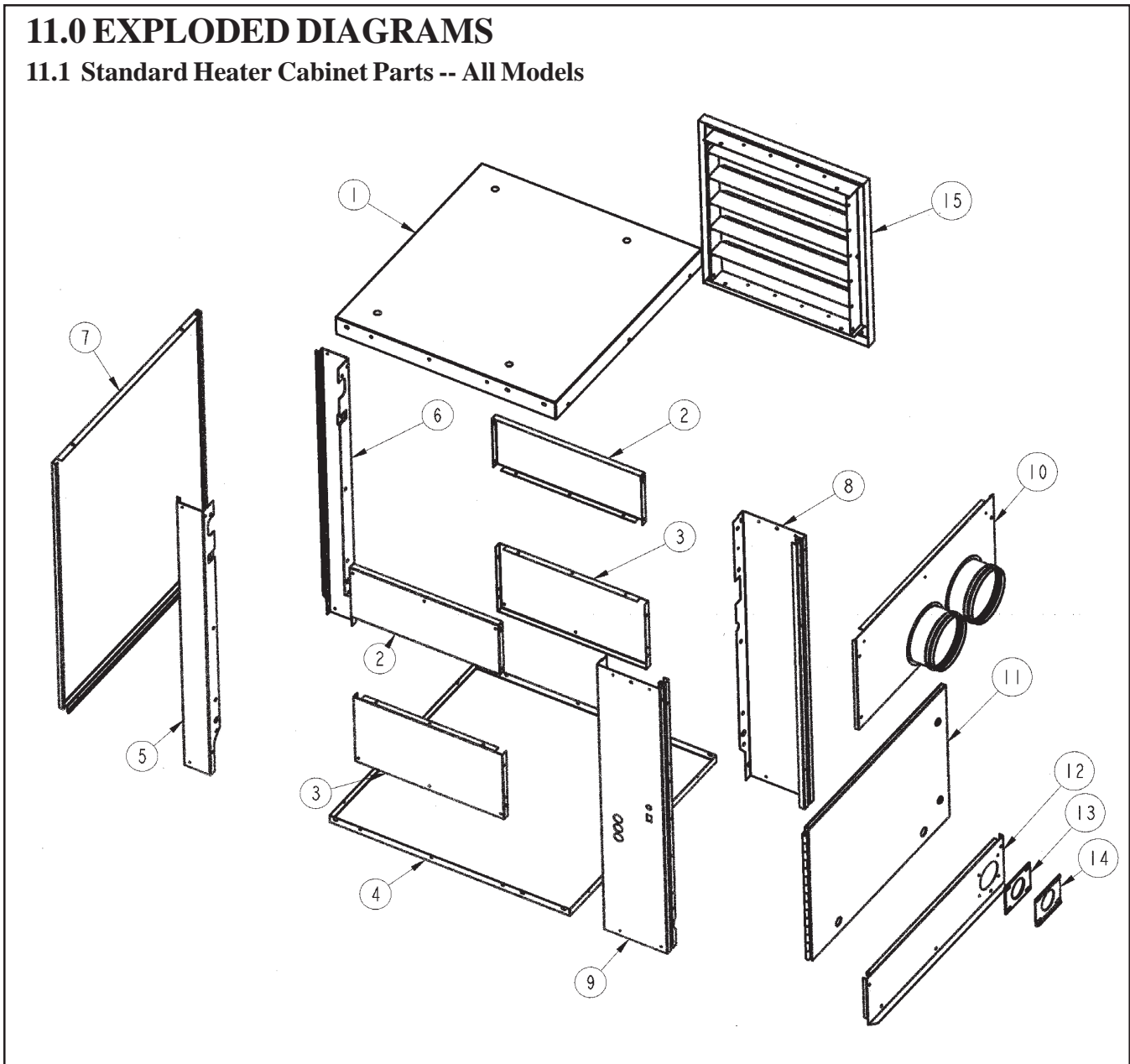

Item No.	Description	Qty	100	125	150	175	200	225	250	300	350	400D	400
1	Casing Top Assy with insulation	1	141178	141179	141180	141180	141181	141181	141182	141182	141183	141184	141184
2	Top Front and Rear Panel	2	10861	10869	10875	10875	10886	10886	10892	10892	10900	10906	10906
3	Bottom Front and Rear Panel	2	9926	9889	9850	9850	9810	9810	9771	9771	9735	9542	9542
4	Bottom Pan Assy - Aluminized	1	125267	125268	125269	125269	125270	125270	125271	125271	125272	125273	125273
	Bottom Pan Assy - Stainless Steel	1	129516	129517	129518	129518	129519	129519	129520	129520	129521	129522	129522
5	Right Rear Corner Leg	1	10309	10309	10309	10309	10311	10311	10311	10311	10311	10311	10311
6	Right Front Corner Leg	1	10310	10310	10310	10310	10312	10312	10312	10312	10312	10312	10312
7	Casing Right Side Panel	1	9853	9853	9853	9853	9547	9547	9547	9547	9547	9547	9547
8	Left Front Corner Leg	1	141734	141734	141734	141734	141735	141735	141735	141735	141735	141735	141735
9	Left Rear Corner Leg	1	141565	141565	141565	141565	141736	141736	141736	141736	141736	141736	141736
10	Top Left Side Panel w/Sockets	1	141786	141786	141786	141786	141787	141787	146060	146060	146060	146060	146060
11	Control Access Panel Assembly	1	141795	141795	141795	141795	141795	141795	141795	141795	141795	141795	141795
12	Bottom Left Access Panel Assy	1	141790	141790	141790	141790	141790	141790	141790	141790	141790	141790	141790
13	Manifold Plate Gasket	1	142267	142267	142267	142267	142267	142267	142267	142267	142267	142267	142267
14	Manifold Plate	1	141794	141794	141794	141794	141794	141794	141794	141794	141794	141794	141794
15	Louvre Frame and Louvre Assy - Model STA only	1	10020	10018	10016	10016	10014	10014	10012	10012	10010	10001	10001

11.2 Standard Heat Exchanger and Burner Rack -- All Models

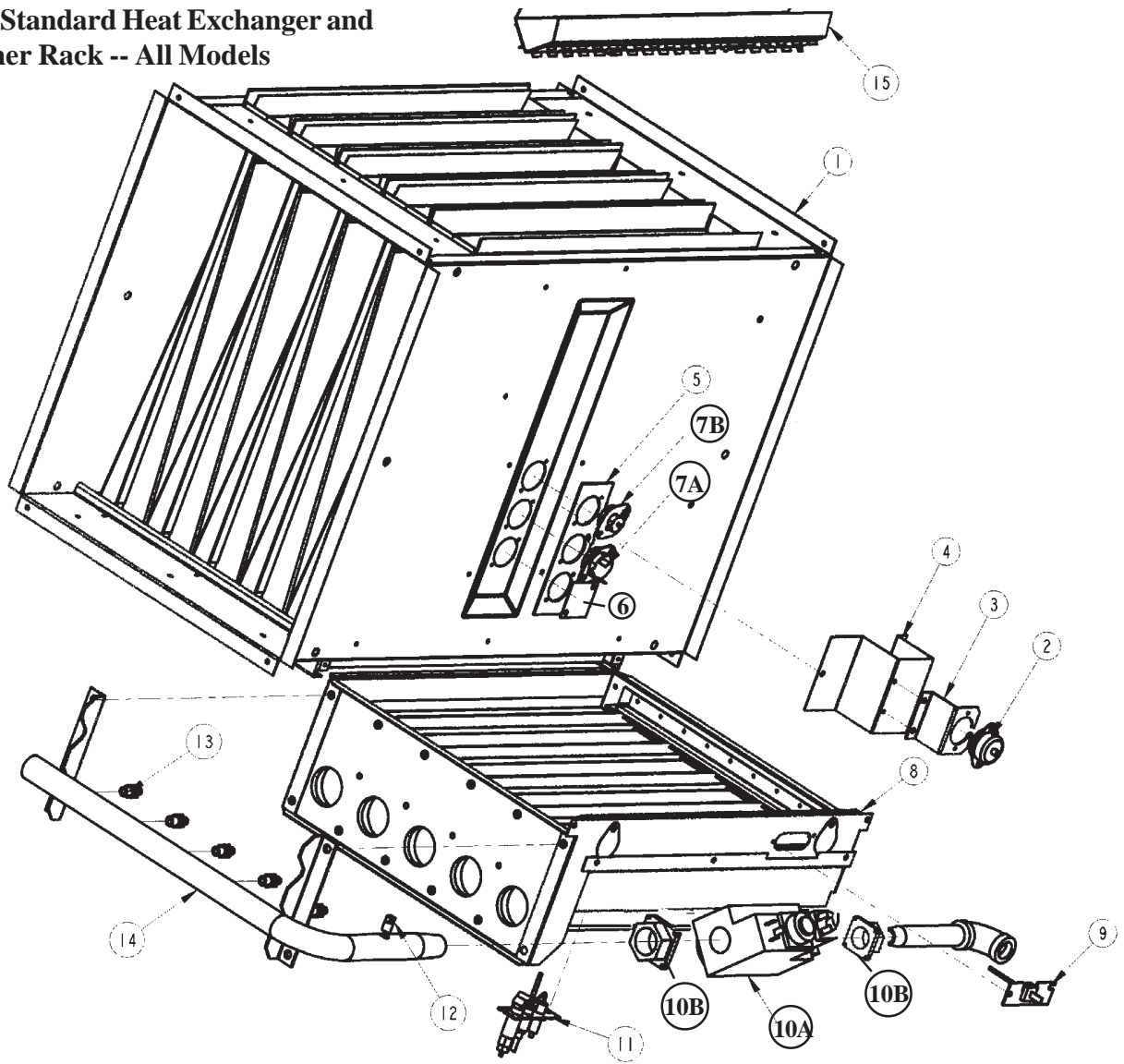

Item No.	Description	Qty	100	125	150	175	200	225	250	300	350	400D	400
1	Heat Exchanger Assy - Aluminized	1	141600	141601	141602	141602	141603	141603	141604	141604	141605	141606	141606
	Heat Exchanger Assy - 409 Stainless	1	145090	145091	145092	145092	145093	145093	145094	145094	145095	145096	145096
	Heat Exchanger Assy - 321 Stainless	1	145097	145098	145099	145099	145100	145100	145101	145101	145102	145103	145103
2	Limit Control with Capillary Tube	1	142692	142692	142692	142692	142692	142692	142693	142693	142693	142693	142693
3	Limit Control Bracket	1	141676	141676	141676	141676	141676	141676	141676	141676	141676	141676	141676
4	Air Tube Bracket	1	141151	141151	141151	141151	141151	141151	141151	141151	141151	141151	141151
5	Fan Control Gasket	1	17083	17083	17083	17083	17083	17083	17083	17083	17083	17083	17083
6	Patch Plate	1	9814	9814	9814	9814	9814	9814	9814	9814	9814	9814	9814
7A	Fan Control	1	141750	141750	141750	141750	141750	141750	141750	141750	141750	141750	141750
7B	High Temperature Limit Control	1	112752	112752	112752	112752	112752	112752	112752	112752	112752	112752	112752
8	Burner Rack Assy - Aluminized	1	125287	125288	125289	125289	125290	125290	125291	125291	125292	125293	125293
	Burner Rack Assy - Stainless Steel	1	131995	131996	131997	131997	131998	131998	131999	131999	132000	132001	132001
9	Auxiliary Sensing Probe	1	126101	126101	126101	126101	126101	126101	126101	126101	126101	126101	126101
10A	Gas Valve	1	142664	142664	142664	142664	134779	134779	134779	134779	134779	134779	134779
10B	Flange	2	—	—	—	—	134809	134809	133913	133913	133913	133913	133913
	O-Ring (not illustrated)	2	—	—	—	—	125842	125842	125842	125842	125842	125842	125842
	Socket Head Screw (Flange to Gas Valve) (not illustrated)	8	—	—	—	—	125843	125843	125843	125843	125843	125843	125843
11	Pilot Assembly	1	142416	142416	142416	142416	142416	142416	142416	142416	142416	142416	142416
12	Pipe Plug	1	142665	142665	142665	142665	142666	142666	142666	142666	142666	142666	142666
13	Main Orifice - Natural Gas	▶	11792 (4)	84437 (5)	11833 (7)	84437 (7)	11828 (9)	84437 (9)	11833 (12)	84437 (12)	84437 (14)	84437 (16)	84437 (16)
14	Manifold	1	141761	141762	141763	141763	141764	141764	141765	141765	141766	141767	141767
15	Tube Baffle Assembly	▶	125170 (4)	125170 (5)	125170 (7)	125170 (7)	125170 (9)	125170 (9)	125170 (12)	125170 (12)	125170 (14)	125170 (16)	125170 (16)
16	Regulator for Optional Electronic Modulation Control (not illustrated)	1	145904	145904	145904	145904	145905	145905	145906	145906	145906	145906	145906
17	Gas Conversion Kit - to G31 propane		146079	146080	146081	146082	146083	146084	146085	146086	146087	146088	146089

11.0 EXPLODED DIAGRAMS (cont'd)

11.3 Standard Flue Collection and Venter Parts -- All Models

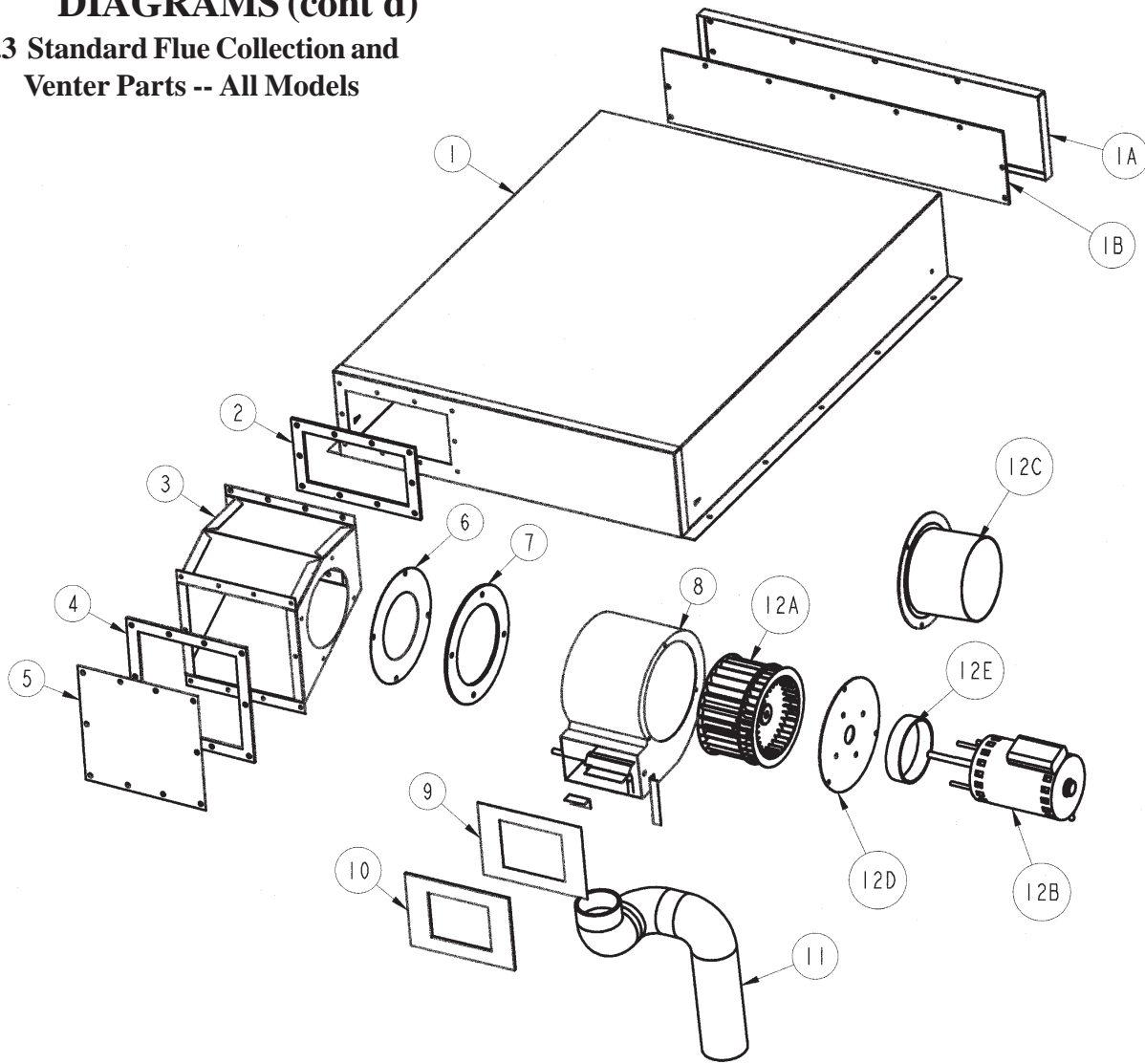

Item No.	Description	Qty	100	125	150	175	200	225	250	300	350	400D	400
1	Flue Gas Collection Box	1	142723	142724	142725	142725	125274	125274	125275	125275	125276	125469	125469
1A	Flue Collection Box Right Side	1	88356	88356	88356	88356	88361	88361	88361	88361	88361	88361	88361
1B	Flue Collection Box Right Side Gasket	1	141062	141062	141062	141062	—	—	—	—	—	—	—
2	Flue Outlet Gasket	1	31900	31900	31900	31900	31900	31900	31900	31900	31900	31900	31900
3	Flue Gas Outlet Duct Assembly	1	41991	41991	41991	41991	41991	41991	141039	141039	141039	141039	141039
4	Gasket	1	41996	41996	41996	41996	41996	41996	41996	41996	41996	41996	41996
5	Flue Gas Outlet Duct Cover Plate	1	41995	41995	41995	41995	41995	41995	41995	41995	41995	41995	41995
6	Combustion Air Orifice	1	125859	88508	88508	142132	68390	43261	142136	142137	142138	142138	—
7	Venter Gasket	1	44695	44695	44695	44695	44695	44695	141812	141812	141812	141812	141812
8	Venter Housing Assembly	1	142282	142282	142283	142283	142284	142284	142285	142285	142286	142286	142286
9	Venter Seal Plate	1	142661	142661	142661	142661	68421	68421	68421	68421	68421	68421	68421
10	Venter Seal Gasket	1	142660	142660	142660	142660	68420	68420	68420	68420	68420	68420	68420
11	Flexible Aluminum Tube	1	141783	141783	141783	141783	141783	141783	141783	141783	141783	141783	141783
12	Venter Motor and Wheel Assy	1	142649	142649	142649	142649	142650	142650	142650	142650	142650	142650	142650
12A	Venter Wheel	1	142658	142658	142658	142658	142659	142659	142659	142659	142659	142659	142659
12B	Venter Motor	1	142480	142480	142480	142480	142480	142480	142480	142480	142480	142480	142480
12C	Venter Motor Mounting Plate with Tube	1	142644	142644	142644	142644	—	—	—	—	—	—	—
12D	Venter Motor Mounting Plate	1	—	—	—	—	142648	142648	142648	142648	142648	142648	142648
12E	Spirol Spacer	4	97721	97721	97721	97721	97721	97721	97721	97721	97721	97721	97721
12F	Venter Motor Support Ring	1	125346	125346	125346	125346	125346	125346	125346	125346	125346	125346	125346

11.4 Model STA -- Standard Heater Cabinet Back and Fan Components

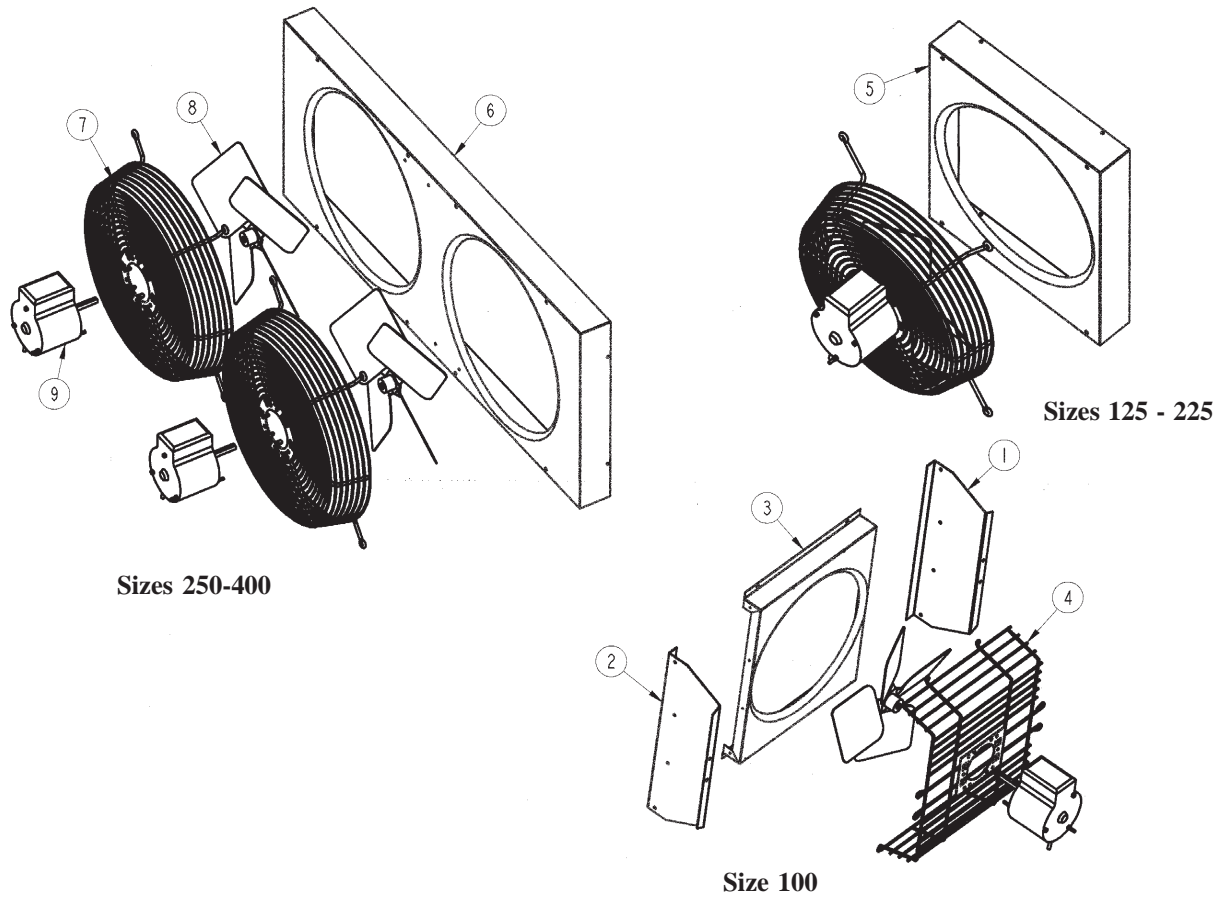

Item No.	Description	Qty	100	125	150	175	200	225	250	300	350	400D	400
1 & 2	Fan Back Sides	2	125136	—	—	—	—	—	—	—	—	—	—
3	Fan Back	1	125137	—	—	—	—	—	—	—	—	—	—
4	Fan Guard Assembly including motor mounting plate	1	114681	—	—	—	—	—	—	—	—	—	—
5 & 6	Casing Back Assembly	1	—	59289	59291	59291	59293	59293	73801	73801	73802	73803	73803
7	Fan Guard	1	—	136950	136949	136949	136949	136949	—	—	—	—	—
		2	—	—	—	—	—	—	136950	136950	136949	136949	136949
8	Fan Blade	1	41004	125563	125564	125564	141598	141598	—	—	—	—	—
		2	—	—	—	—	—	—	125566	125566	125564	141598	141598
9	Fan Motor	1	121277	121277	121277	121277	126688	126688	—	—	—	—	—
		2	—	—	—	—	—	—	121277	121277	126688	126688	126688

11.0 EXPLODED DIAGRAMS (cont'd)

11.5 Models STB and STE - Standard Heater Cabinet Back and Blower Components

Blower Mounting Assembly for Dual Blowers, Sizes 250-400

Motor Mounting Assembly for Motors 1HP and Larger

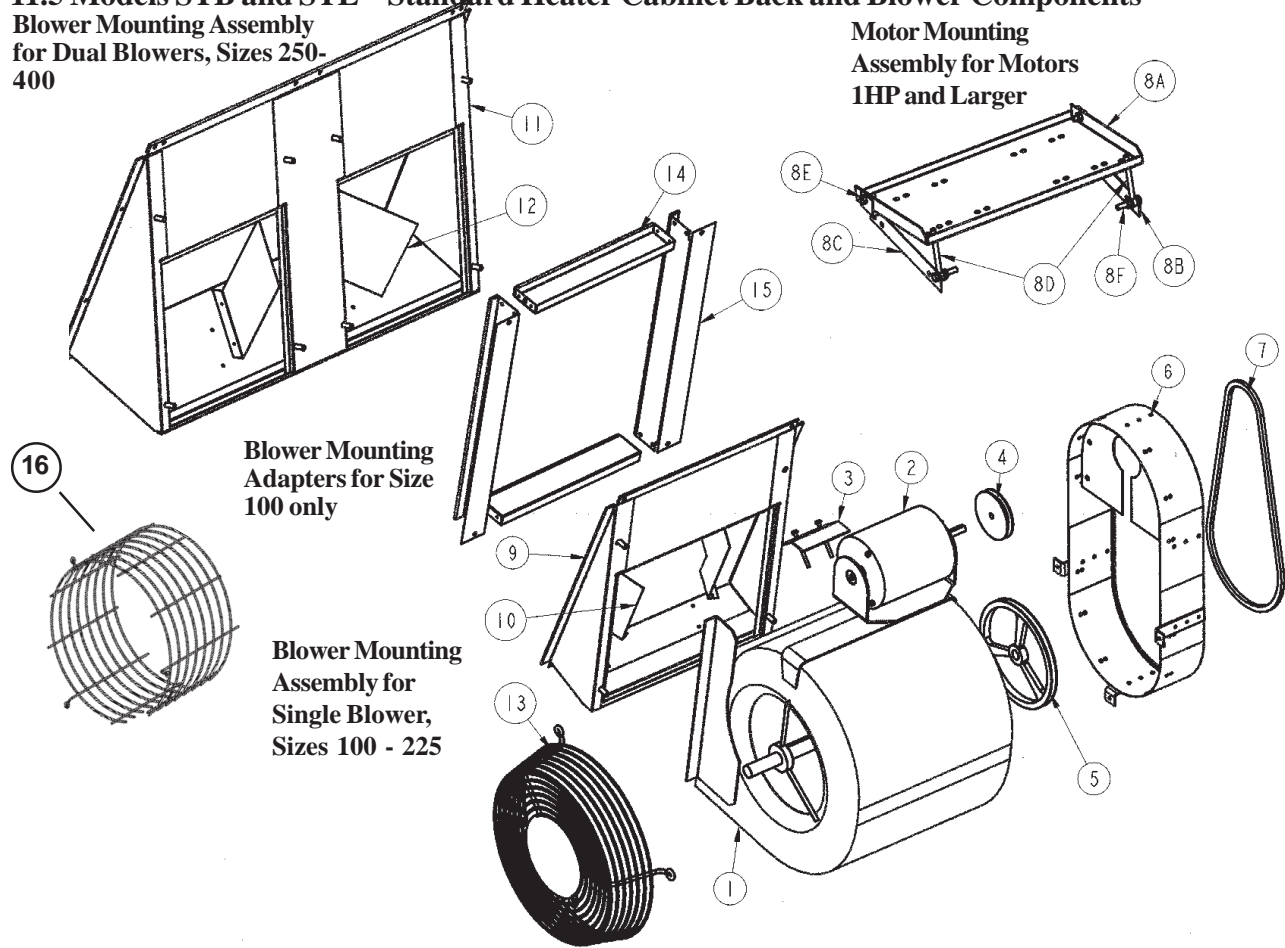

Blower Mounting Adapters for Size 100 only

Blower Mounting Assembly for Single Blower, Sizes 100 - 225

Item No.	Description	Qty	100	125	150	175	200	225	250	300	350	400D	400
1	Blower	1	36428	36428	36429	36429	36429	36429	36430	36430	36432	36432	36432
		1	—	—	—	—	—	—	36431	36431	36433	36433	36433
	Blower Bearings	2	—	—	—	—	—	—	10437	10437	10437	10437	10437
	Blower Shaft	1	—	—	—	—	—	—	10120	10120	10121	10121	10121
2	Blower Motor	1	113761	113761	113761	113761	113762	113762	113763	113763	113764	113764	113764
	Blower Motor Contactor	1	—	—	—	—	133436	133436	133436	133436	133436	133436	133436
3	Motor Adjustment Bracket Assembly	(for motors	1	12585	12585	12585	12585	12585	—	—	—	—	—
	Hardware Bag including Rubber Feet for Adjustment Screws	less than 1HP)	1	64940	64940	64940	64940	64940	—	—	—	—	—
4	Motor Sheave	1	13580	13580	13580	13580	13580	13580	13659	13659	13659	13659	13659
5	Blower Sheave	1	116394	116394	116398	116398	116397	116397	116398	116398	105483	105483	105483
6	Belt Guard (Model ST B only)	1	42801	42801	42807	42807	42807	42807	42801	42801	42807	42807	42807
7	Drive Belt	1	10960	10960	7949	7949	10960	10960	105490	105490	105493	105493	105493
8A	Motor Mounting Plate	(for motors 1HP and larger)	1	—	—	—	—	—	12579	12579	12579	12579	12579
8B	Motor Mounting Plate Left Support		1	—	—	—	—	—	12576	12576	12576	12576	12576
8C	Motor Mounting Plate Right Support		1	—	—	—	—	—	12577	12577	12577	12577	12577
8D	Rod Bolt 5/16-18		2	—	—	—	—	—	12489	12489	12489	12489	12489
8E	Hex Nut 5/16-18		2	—	—	—	—	—	1035	1035	1035	1035	1035
8F	Hex Nut 5/16-18 (Keps)		6	—	—	—	—	—	6554	6554	6554	6554	6554
9	Blower Mounting Plate Assembly	1	17421	17421	17449	17499	17491	17491	—	—	—	—	—
10	Air Baffle	2	—	68434	68434	68434	68435	68435	—	—	—	—	—
11	Blower Mounting Plate Assembly	1	—	—	—	—	—	—	17510	17510	17528	17542	17542
12	Air Baffle	2	—	—	—	—	—	—	68435	68435	68435	68435	68435
13	Blower Inlet Guard (ST B only)	1	102474	102474	102475	102475	102475	102475	102474	102474	102475	102475	102475
14	Blower Adapter Top and Bottom	2	53277	—	—	—	—	—	—	—	—	—	—
15	Blower Adapter Sides	2	53278	—	—	—	—	—	—	—	—	—	—
16	Double Blower Guard (ST B only)	2	—	—	—	—	—	—	143575	143575	143575	143575	143575

11.6 Model STE - Standard Blower Cabinet Parts

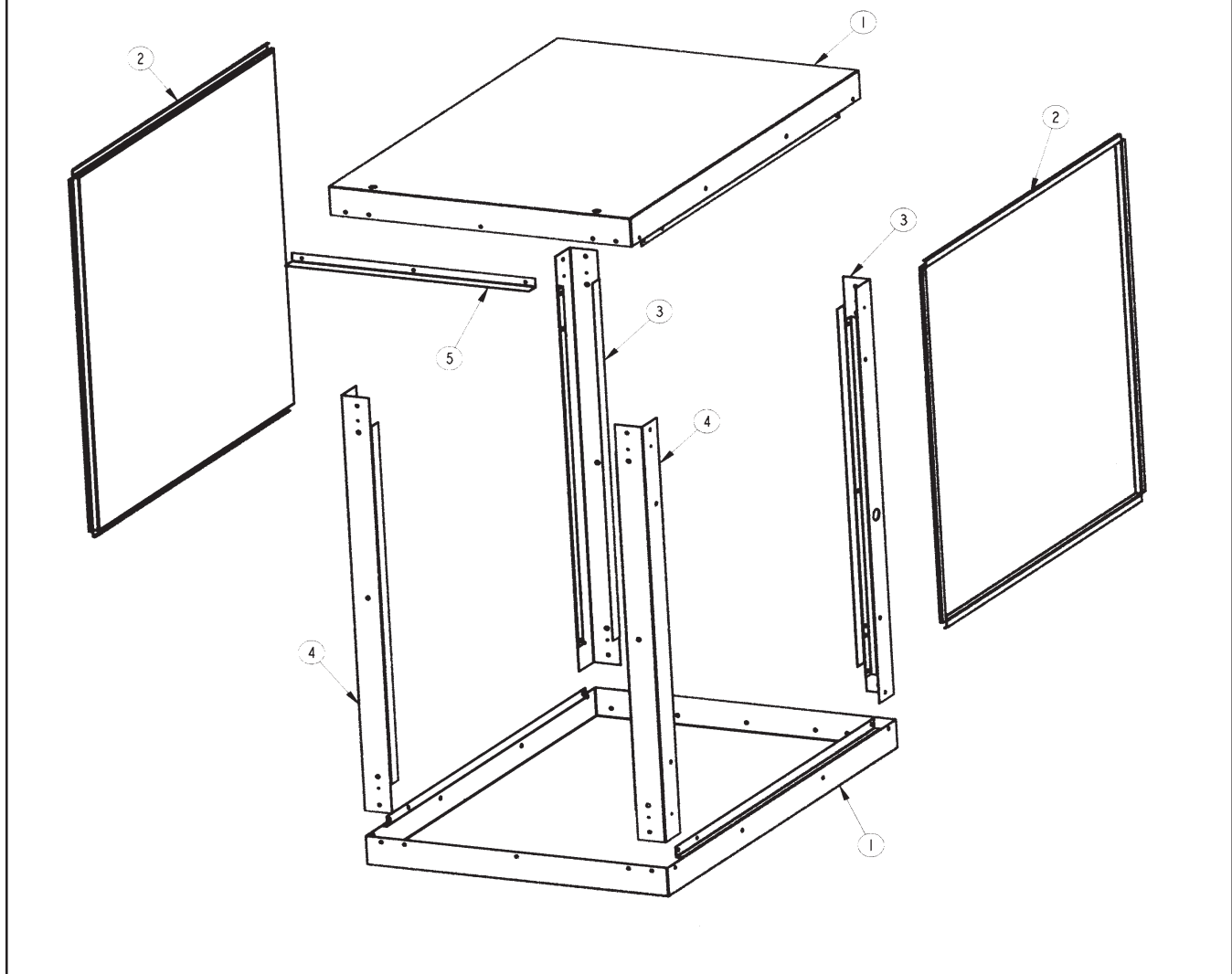

Item No.	Description	Qty	100	125	150	175	200	225	250	300	350	400D	400
1	Top and Bottom Assembly	2	11522	11522	11529	11529	11197	11197	11564	11564	11574	11583	11583
2	Door Panel	2	51041	51041	51041	51041	51042	51042	51042	51042	51042	51042	51042
3	Corner Support	1	11518	11518	11518	11518	11211	11211	11211	11211	11211	11211	11211
	Corner Support	1	11519	11519	11519	11519	19982	19982	19982	19982	19982	19982	19982
4	Corner Support	2	11517	11517	11517	11517	11210	11210	11210	11210	11210	11210	11210
5	Top Duct Connecting Angle	1	11523	11523	11530	11530	11536	11536	11567	11567	11576	11584	11584

11.0 EXPLODED DIAGRAMS (cont'd)

11.7 Model STE - Filter Arrangements

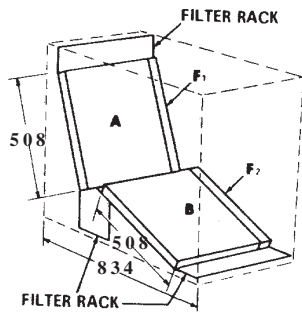

Sizes 100-175

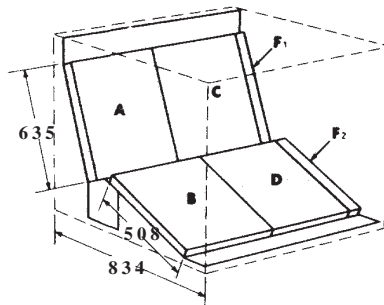

Sizes 200-350

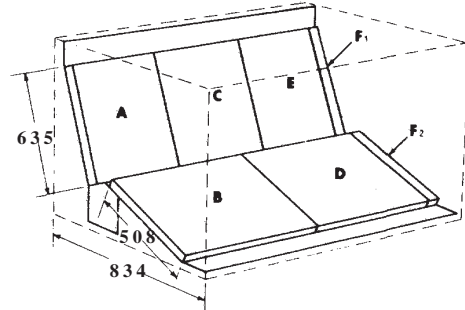

Sizes 400D & 400

Model STE Size	Dimensions (mm)						
	Filters					Metal Fillers	
	A	B	C	D	E	F1	F2
100	508 x 508	508 x 508					
125	508 x 508	508 x 508					
150	508 x 635	508 x 635				21	21
175	508 x 635	508 x 635				21	21
200	406 x 635	406 x 508	406 x 635	406 x 508			
225	406 x 635	406 x 508	406 x 635	406 x 508			
250	508 x 635	508 x 508	508 x 635	508 x 508			
300	508 x 635	508 x 508	508 x 635	508 x 508			
350	508 x 635	508 x 635	508 x 635	508 x 508		122	
400D	406 x 635	508 x 635	406 x 635	508 x 635		67	27
400	406 x 635	508 x 635	406 x 635	508 x 635	406 x 635	67	27

12.0 SHORT LIST OF PARTS

Component	SIZE											
	100	125	150	175	200	225	250	300	350	400D	400	
Pilot Burner Assembly including Injector	142416	142416	142416	142416	142416	142416	142416	142416	142416	142416	142416	142416
Auxiliary Sensing Probe	126101	126101	126101	126101	126101	126101	126101	126101	126101	126101	126101	126101
Ignition Controller	134780	134780	134780	134780	134780	134780	134780	134780	134780	134780	134780	134780
Fan Control	141750	141750	141750	141750	141750	141750	141750	141750	141750	141750	141750	141750
Limit Control with Capillary	142692	142692	142692	142692	142692	142692	142693	142693	142693	142693	142693	142693
HighTemperature Limit Control	121275	121275	121275	121275	121275	121275	121275	121275	121275	121275	121275	121275
Reset Switch	121925	121925	121925	121925	121925	121925	121925	121925	121925	121925	121925	121925
Indicator Light	122075	122075	122075	122075	122075	122075	122075	122075	122075	122075	122075	122075
Injector - Main (G20 Gas)	11792	84437	11833	84437	11828	84437	11833	84437	84437	84437	84437	84437
Natural Gas	(4)	(5)	(7)	(7)	(9)	(9)	(12)	(12)	(14)	(16)	(16)	(16)
Injector - Main (G31 Gas)	61652	61652	97360	61652	11834	61652	97360	61652	61652	97360	61652	61652
Propane Gas	(4)	(5)	(7)	(7)	(9)	(9)	(12)	(12)	(14)	(16)	(16)	(16)
Gas Control (Valve)	142664	142664	142664	142664	134779	134779	134779	134779	134779	134779	134779	134779
Pressure Switch	142653	142653	142653	142654	142655	142654	142653	142654	142653	142653	142654	142654
Venter Wheel	142658	142658	142658	142658	142659	142659	142659	142659	142659	142659	142659	142659
Venter Motor	142480	142480	142480	142480	142480	142480	142480	142480	142480	142480	142480	142480
Axial Fan Motor - STA	121277	121277	121277	121277	121277	121277	121277	121277	126688	126688	126688	126688
	(1)	(1)	(1)	(1)	(1)	(1)	(2)	(2)	(2)	(2)	(2)	(2)
Centrifigal Blower Motor - STB/E	113761	113761	113761	113761	113762	113762	113763	113763	113764	113764	113764	113764
(standard size; check motor size)	.5 HP	.5 HP	.5 HP	.5 HP	.75 HP	.75 HP	1 HP	1 HP	1.5 HP	1.5 HP	1.5 HP	1.5 HP

A "replacement parts tag" listing the most common replacement parts is affixed to the rear of the heater. Each tag is "custom made" for that particular size and style of heater.



Sales & Service by:

AMBI-RAD Ltd

P. O. Box No. 30

Mucklow Hill

Halesowen

West Midlands B62 8DS

Telephone 0121 503 0707

Fax 0121 501 2955