

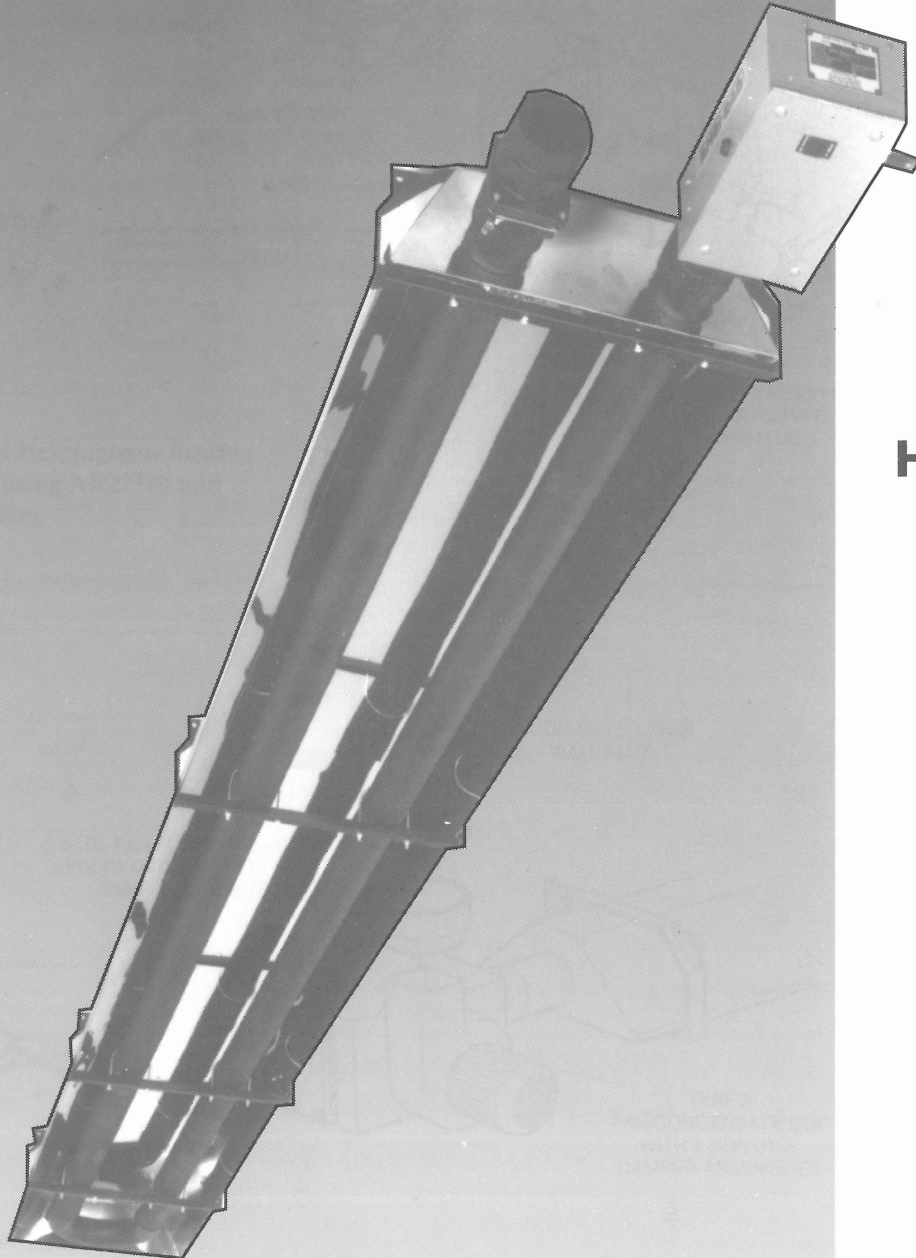

# INSTRUCTION AND INSTALLATION MANUAL



**FOR**  
|  
**THE**  
|  
**HERRINGBONE**  
|  
**COMBINED**  
|  
**FLUE**  
|  
**HEATING**  
|  
**SYSTEM**



# INSTALLATION INSTRUCTIONS FOR AMBI-RAD ER/AR/RB/'U' TUBE & LINEAR HERRINGBONE HEATING SYSTEMS

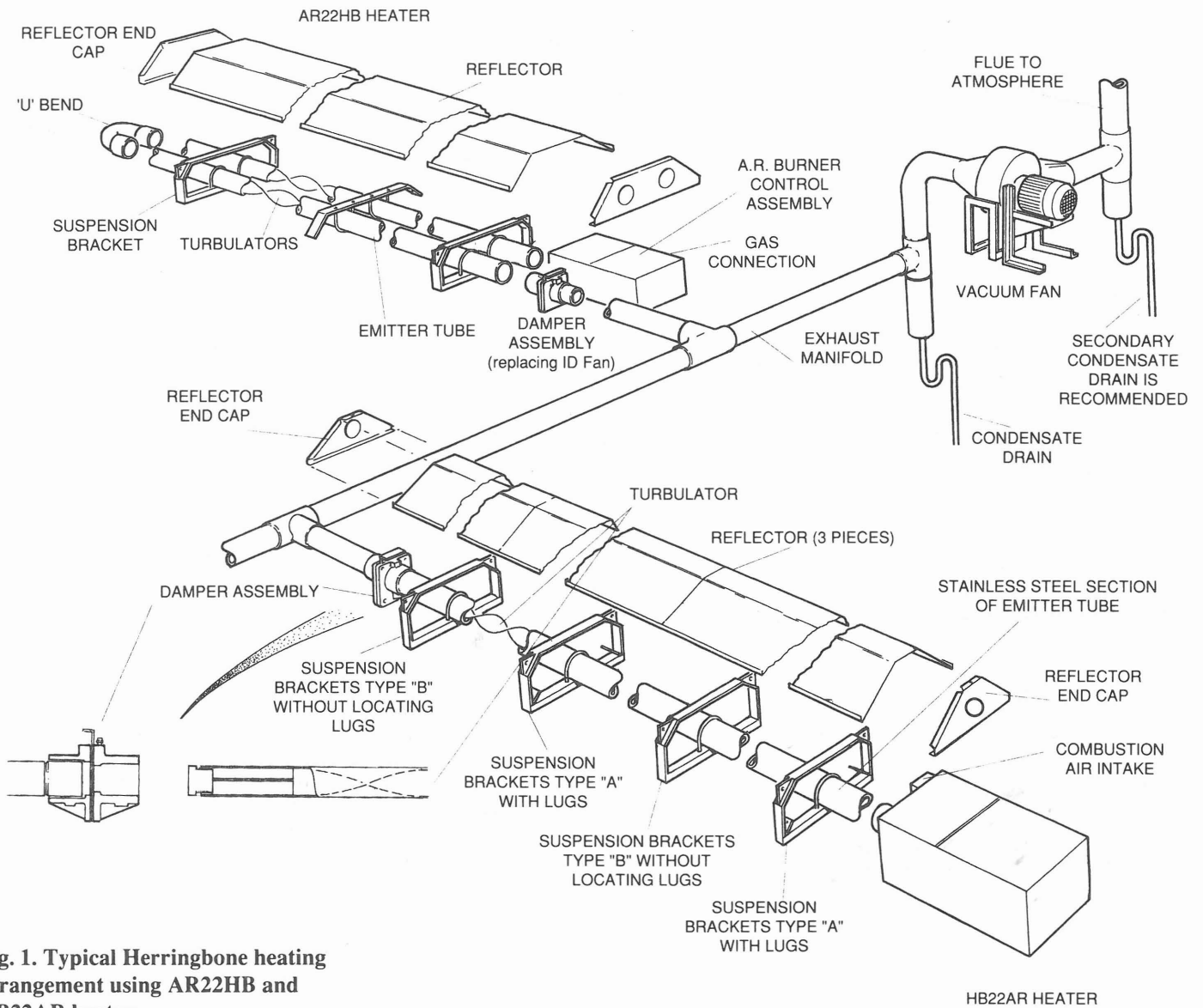

**Fig. 1. Typical Herringbone heating arrangement using AR22HB and HB22AR heaters.**

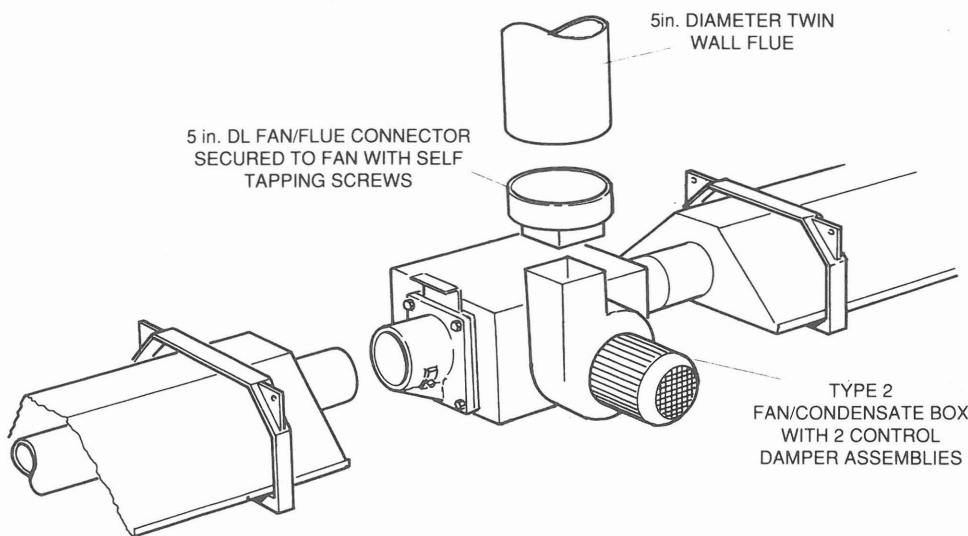

**For heater assembly instructions and fixing heights refer to:**

- ER U TUBE - Doc ref 74**
- ER LINEAR - Doc ref 76**
- AR U TUBE - Doc ref 75**
- AR LINEAR - Doc ref 77**
- RB U TUBE - Doc ref 78**
- RB LINEAR - Doc ref 79**
- AR DL - Doc ref 80**

**Fig.2. DL Heater arrangement.**

# 1. GENERAL ARRANGEMENT OF AMBI-RAD HERRINGBONE SYSTEM

The Ambi-Rad Herringbone HB combined flue system may consist of either 'U' tube or linear heaters, linked into a common aluminium manifold system, which in turn is coupled to one hot gas vacuum fan to 'evacuate' the products of combustion to atmosphere.

**Please refer to the Design Manual to ensure correct manifold design.**

The following appliances are tested and certified by an accredited test house for use on natural gas and propane:

RB18HB	GC No 36 229 25	RB30HB	GC No 36 229 27		
HB18RB	GC No 36 229 28	HB30RB	GC No 36 229 29	HB22	GC No 36 229 02

As each HB heater is self contained and independently commissioned, the design layout of a Herringbone heating system is very flexible and easy to install.

The system is controlled via an Ambi-Rad black bulb thermostat whose controller is housed in a lockable cabinet with fan starter and time switch.

The Ambi-Rad Herringbone combined flue system manifold layout should be designed to be as compact as possible (but not essential) with the final connection to the hot gas vacuum fan approximately central in the manifold system. Please refer to document ref 200/9/92 Ambi-Rad Herringbone Design Manual.

The manifold system should be arranged to fall slightly in the direction of the hot gas vacuum fan to ensure that any condensate formed in the manifold on cold start and cool down is not trapped or allowed to drain back into the heater unit so it will flow towards the condensate trap located at the vacuum fan end. See Fig. (10) for Condensate Trap arrangement.

The flue should be adequately supported from the building structure and installed in accordance with the British Standard Code of Practice - Flues for Gas Appliances, Local and Ministry Authorities and Building Regulations. Alternatively, a telescopic through the wall discharge duct is available for either Type 0, Type 1 or Type 2 (available from Ambi-Rad).

Ambi-Rad will, upon receipt of a proposed drawing showing a Herringbone combined flue system, check the pressure drop of the manifold system to ensure it does not exceed the hot gas vacuum fan design criteria.

## 1.1 Standards

The Ambi-Rad heater must be installed in accordance with the relevant provisions of the Gas Safety (Installations and Use) Regulations 1984 (as amended). Due account should also be taken of any obligations arising from the Health and Safety at Works etc. Act 1974. In addition the installation must be carried out in accordance with the current I.E.E. Regulations, The Building (Standards) (Scotland) Consolidation Regulations, the requirements of BS.5440: Part 1, BS.6891: 1988, BS.6896: 1991 and any other relevant British Standards and Codes of Practice.

## 1.2 Ventilation Requirements

A flue pipe should be adequately supported at regular intervals from the building structure and terminated externally as shown in Fig.10. The maximum flue length and maximum number of bends should be calculated in accordance with the Ambi-Rad Herringbone Design Manual. All connections in the flue pipe must be properly sealed. Permanent ventilation is required as follows:-

Natural Ventilation (preferably at low level)

Up to and including 60kW - 4.5cm<sup>2</sup>/kW

Over 60kW - 270cm<sup>2</sup> + 2.25cm<sup>2</sup>/kW in excess of 60kW total input.

Forced Ventilation

Minimum proven air flow - 2.35 m<sup>3</sup>/h kW of total rated input.

For detailed information please refer to Ambi-Rad Design Manual and/or BS6896: 1991, Installation of Gas Fired Overhead Radiant Heaters for Industrial and Commercial Heating.

## 2.0 MANIFOLD ASSEMBLY

After fixing the heaters in to the desired position, the manifold system should be laid out on the floor, where possible, to the design layout before erecting. All joints must be sealed with high temperature silicon jointing compound and components pop-riveted together. See Fig. 3 and Fig. 4.

After allowing for a minimum of 50mm (2in) of penetration of the fitting into the tube, cut the tubes to the lengths required and remove all burrs and wipe off any grease or oil with a clean rag.

### 2.1 Method of Jointing Aluminum Tube

Using the applicator gun exude a 4mm diameter bead of high temperature silicon jointing compound externally round the end of the fitting and internally round the end of the tube. See Fig. (3).

Fig. 3

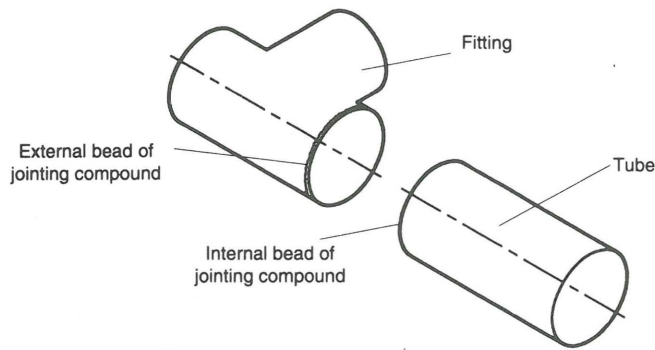

Enter the fitting into the tube using a slight rotating movement to spread the jointing compound uniformly until a penetration of 50mm (2in) is achieved.

Note: The silicon jointing compound remains workable after application for only five minutes.

Secure the joint by drilling through the tube and fitting and fix with three pop rivets at 12 o'clock, 4 o'clock and 8 o'clock positions. 3-5mm (3/16)dia. pop rivets are recommended. See Fig. (4).

Fig. 4

**Important - fit rivets and jointing compound.**

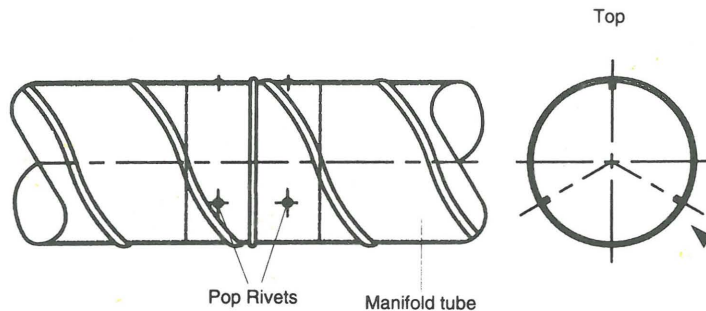

Note: Do not fix rivets in the underside of the tube in order to avoid risk of leakage of condensate.

## 2.2 Damper Assembly

The Damper Assembly secured to the outlet end of the heater unit must be located with its damper blade vertical and left in the closed position. The manifold tube to be sealed and secured as described in Fig.3 & 4 above to the damper assembly. For damper assembly see Fig. (5).

Fig. 5

**Important - fit damper in vertical position.**

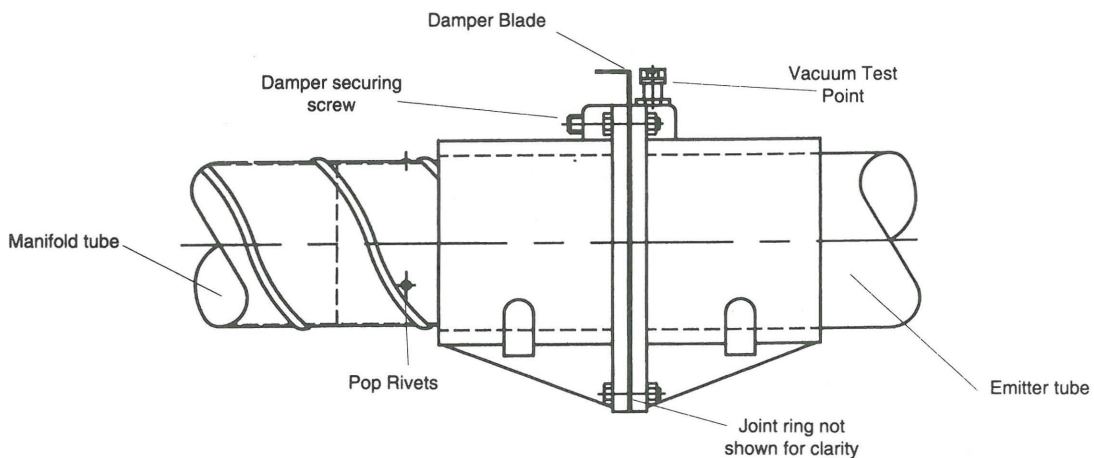

## 2.3 Manifold Suspension

The manifold should be supported by chain, stainless steel flexible wire, or other flexible means from the roof structure to allow movement caused by thermal expansion. For maximum support centres, see Fig. (6).

Flexible couplers (supplied by Ambi-Rad) must be inserted within the manifold system to allow linear expansion to take place and prevent stress and strain on the system.

Note: The manifold must be supported either side of the flexible coupler.

Fig. 6

Manifold Pipe Size	Maximum Distance Between Supports
75mm & 100mm	2.4m (8ft)
150mm & 200mm	3.0m (10ft)

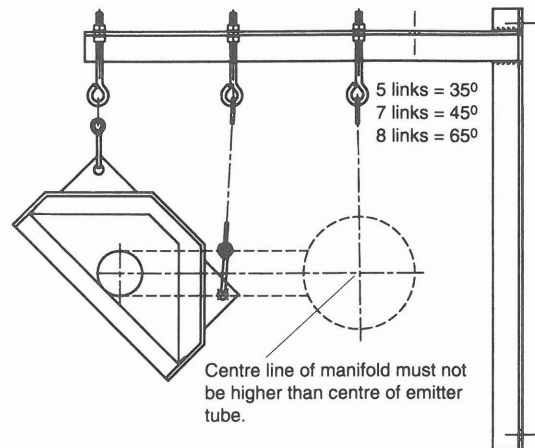

Fig. 7

Where the HB heaters are to be inclined wall mounted, the manifold must NOT be installed higher than the centre of the emitter tube. For typical wall mounting bracket arrangement see Fig. (7).

## 2.4 Condensate Trap

A condensate trap assembly must be provided at the exit from the manifold and before the hot gas vacuum fan. See Fig. (10a).

The minimum depth of the condensate collecting chamber shall be 305mm (12in.) and the minimum depth of the condensate drain pipe 'U' Trap shall be 457mm (18in.) deep.

The end of the collecting chamber to be fitted with a flush fitting flanged tank connector. Any protusion to be removed leaving the inside flush with end cap. See Fig. (11). The end cap to be sealed with silicon jointing compound and pop-riveted in position.

All condensate drains from the flue collecting chamber to the disposal point shall be of corrosion-resistant material of not less than 22mm internal diameter. Copper or copper based alloy shall not be used for condensation drains. See Ref: BS 6896:1991. Condensate drain pipes must be protected against the effects of freezing.

Fig. 8a. Dimensions of Fan Outlet - Type 0 & Type 1 fan.

Fig. 8b. Outside Dimensions of Fan Outlet - Type 2 fan

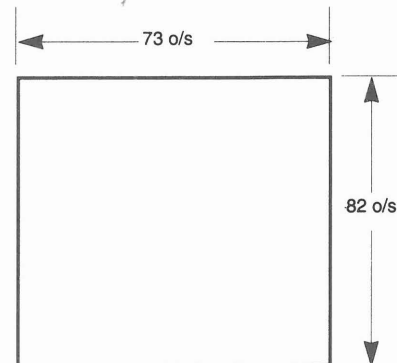
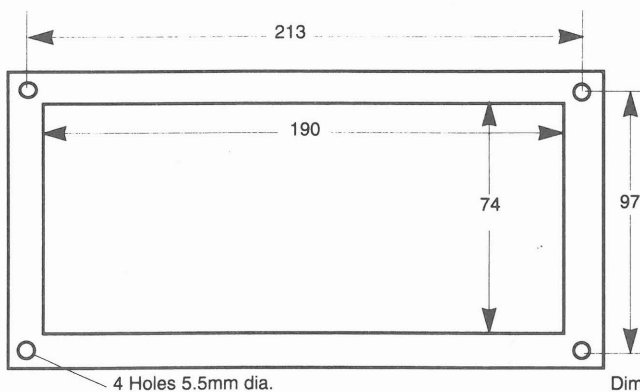

Dimensions in mm.

## 3.0 FAN TO FLUE ARRANGEMENT

The type '0', type '1' and type '2' Vacuum fans have bottom horizontal discharge with rectangular flanged connections and must be mounted in that position by means of the fan support stool onto a suitable platform or brackets fixed to the building structure. For details of the fan outlet flange fixing holes see Fig. (8a & 8b). For details of fan mounting bracket and fixing down holes see Fig.(9).

- There are two recommended methods of discharging the products of combustion.
- A conventional flue arrangement using twin wall flue. See Fig. (10c) & (10d).
  - A telescopic through the wall flue with bird cage cover. See Fig. (10e).

Where a conventional flue is to be installed, Ambi-Rad supply a stainless steel square to round transformation piece to which a 6" diameter twin wall flue should be attached.

The maximum length of flue which may be connected to the fan outlet must be calculated in accordance with the Ambi-Rad Herringbone Design Manual Doc ref: 200/10/92 and must be adequately supported from the building structure.

Exhaust Flues should be installed in accordance with the British Standard Code of Practice BS.5440, Part 1 - Flues for Gas Appliances, I.E.E. Regulations, Local Ministry Authorities and Building Regulations.

## DO'S AND DON'TS of HERRINGBONE SYSTEMS

### DO'S

- Do check design pressure drop.
- Do check for corrosive industrial processes in proposed building - e.g., cleaning, electroplating, printers using sugar powder etc.
- Do drain all flue ducts and seal all joints.
- Do secure joints with pop rivets as well as sealing compound. See Fig.3 & 4.
- Do fit drain traps before and after fans (see Fig.10.).
- Do fit expansion joints before fan and at intermediate points on the Herringbone system.
- Do run drains in galvanised steel or plastic pipe.
- Do follow guide to Combined Flue Heating System.

### DON'Ts

- Do not install system with extra 90 degree bends without asking Ambi-Rad if the system will operate correctly.
- Do not run drains in copper pipe as it will corrode.
- Do not install flue going upwards without fitting a drain point at lowest level.
- Do not fit fan with outlet pointing vertically upwards or with top horizontal discharge
- Do not fit damper assembly upside down or on its side. See Fig.(5).

**Fig.9. Vaccum fan mounting details.**

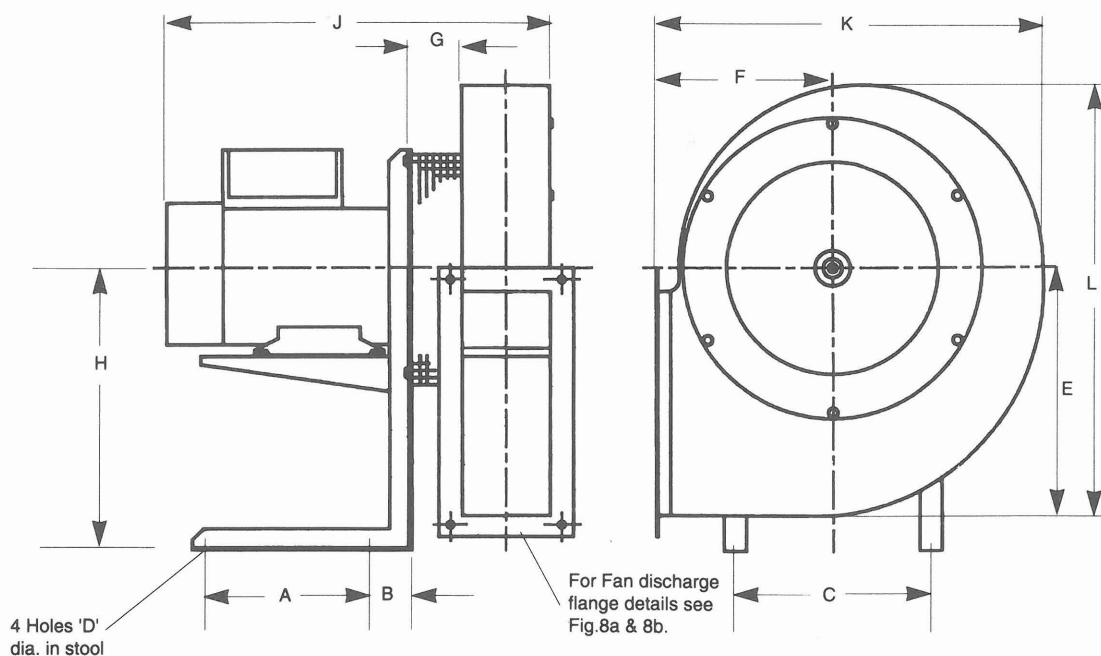

FAN TYPE	DIMENSIONS IN mm.										
	A	B	C	D	E	F	G	H	J	K	L
0	124	38	175	7.1	209	153	42	239	340	332	363
1	124	38	175	7.1	209	153	42	239	296	332	363
2	80	35	174	7	125	100	25	120	210	205	215

**Fig.10. Conventional fan to flue arrangements.**

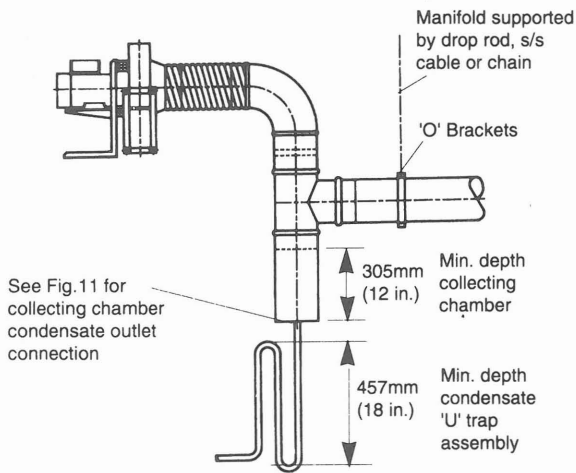

**Fig.10a. High Fan Arrangement**

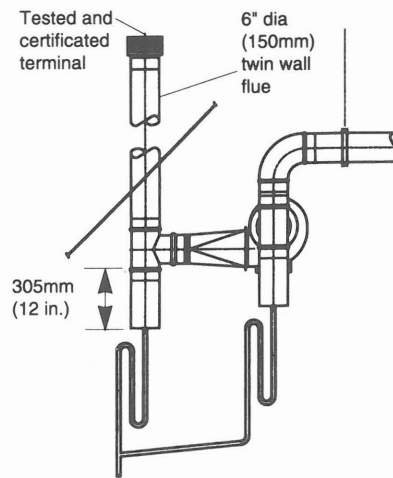

**Fig.10c.**

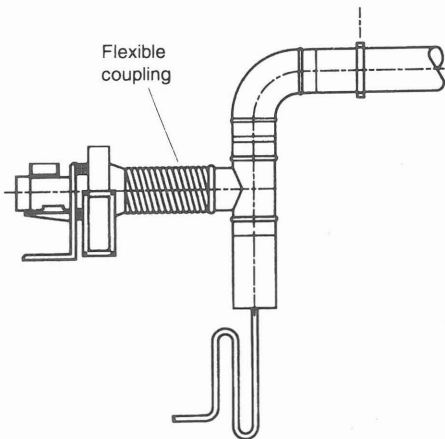

**Fig.10b. Low Fan Arrangement**

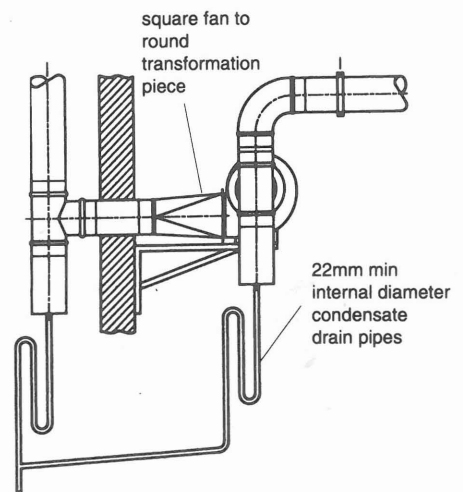

**Fig.10d.**

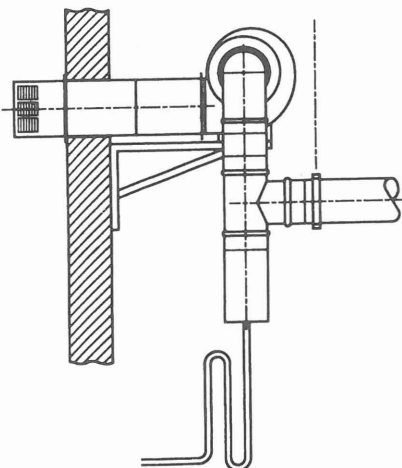

**Fig.10e. Stainless steel telescopic through the wall arrangement (available for Type '0', Type 1 and Type 2 Fans).**

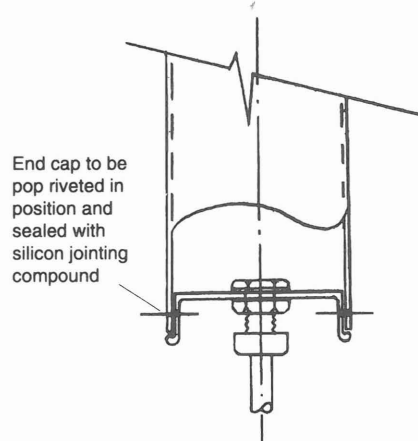

**Fig.11. Collecting Chamber Arrangement**

## 4.0 Commissioning

Inspect installation and ensure it has been carried out in accordance with these instructions. Ensure that electrical and gas supplies are isolated.

The gas supply should be purged and tested for soundness in accordance with the British Standard BS 6891: 1988, BG1M/16 BGC Report IM/2 and any other British Standards and Codes of Practice.

Ensure that the settings of any time switch and thermostat are such that the heating system will be required to operate (or put the mode switch to 'constant').

Before attempting to start up the heating system it is essential to perform the preliminary balancing of the vacuum level at each burner unit.

Isolate each heater unit by unplugging each electrical connector and closing each gas isolating valve.

Adjust the damper at exit of each heater using a 4mm hexagon wrench in the M8 locking screw. Observing the vacuum reading using a 'U' tube manometer connected to the vacuum test point (see Fig. 5.), set each damper in turn to give a hot conditions reading as below.

**Fig.12 Damper Settings.**

HEATER TYPE	DAMPER SETTING HOT CONDITIONS	
	mbar	in. w.g.
ER13HB	1.67	0.67
HB13	1.52	0.61
ER22HB	1.22	0.49
HB22	1.00	0.40
ER38HB	1.12	0.45
HB38	1.00	0.40
AR13HB	1.67	0.67
HB13AR and A13/DL	1.52	0.61
AR22HB	1.49	0.60
HB22AR and AR22DL	1.25	0.50
AR35HB	1.02	0.41
HB35AR and AR35/DL	1.00	0.40
RB18HB	1.40	0.55
HB18RB and RB18DL	1.40	0.55
RB30HB	1.40	0.55
HB30RB and RB30/DL	1.00	0.44

After initial setting of damper re-check when system is at equilibrium.

### Referring Now to Each Individual Heater Unit

Open isolating valve and test gas connections for soundness using leak detecting solution. Remove the combustion chamber cover plate by unscrewing the fixing screws. Take care not to damage the sealing gasket. Inspect the burner and electrode assemblies ensuring these are securely fixed and all electrical connections securely made. Replace the cover plate ensuring that the sealing gasket is correctly positioned and the screws are fully tightened. The heater will not operate until this plate is refitted.

Remove the safety control housing cover plate by unscrewing the securing screws and folding down/lifting off the plate.

Ensure all internal components are securely fixed and all connections securely made.

Reinsert the electrical connector to the burner control assembly.

To allow the heater to start up it is necessary to switch off the whole system at the timeswitch or manual switch and to allow the fan to stop completely before switching on again. At this point the individual heater unit will start up with the following sequence.

The red "mains on" lamp will illuminate and the main fan will start to run. Safe-start checks are carried out automatically. After the fan has run up to full speed and a satisfactory vacuum condition been established at the burner, a purge period of approximately 9 seconds will commence.

At the end of the purge period the ignition sequence will commence. The spark ignition will be energised producing a spark at the ignition electrode. The gas solenoid valve is energised and will open.

If ignition is successful the flame is detected by the flame sensing probe and the ignition spark is switched off. The amber "burner on" lamp indicates that the gas solenoid valve is energised.

If ignition is unsuccessful the gas valve is closed and the spark ignition de-energised after approximately 4 seconds. After unsuccessful ignition attempt the electronic sequence controller will "lock out", the red "mains on" lamp only will remain illuminated. To re-set this "lock out" condition, switch the power supply to the system, wait until the fan stops completely then re-start it. If repeated lock-out occurs, investigate the cause.

Note that if an individual burner assembly unit is switched off and re-connected it cannot restart. The fan must stop running before the burner can be restarted.

To shut down the heaters switch off the power supply to the system. Automatic control of the heating system is achieved through the lockable control panel, incorporated in the electrical supply, which may contain a time switch, Black Bulb Controller with day and night settings, a 3 position mode switch giving constant on/off auto control and fan starter. It is essential to allow a delay of 30 seconds after switching off heaters before attempting to re-start the system.

If at any time after completion of the start up sequence loss of flame should occur, the electronic sequence controller will attempt to re-ignite. If this is unsuccessful, heater lock-out will occur.

To set the burner gas pressure: Close gas valve. Unplug mains input connector to heater. Unscrew the fixing screws of the safety control housing lid and remove pressure test point screw and connect a 'U' tube manometer to the pressure test nipple (located between the pressure regulator and solenoid gas valve). Remove the cover from the pressure regulator to reveal the adjusting screw.

Replace mains input connector, open gas valve and start system.

Using a suitable screwdriver, adjust the pressure regulator, turning the screw clockwise to increase the pressure or anti-clockwise to decrease the pressure. Set the burner pressure to the required figure given on the data label. Switch off the heater by pulling out the mains connector. Disconnect 'U' tube manometer and refit screw in pressure test nipple. Refit cover of pressure regulator. Replace cover plate on safety control housing and refit screws.

To re-ignite heater, switch system off at control panel. Wait until fan stops completely and then re-start system.

Check the operation of the flame safeguard equipment as follows: With the heater running normally switch off the gas supply at the appliance isolating valve. Observe that the "burner on" lamp extinguishes within one second. After a purge period of approximately 9 seconds the heater should attempt to relight and if the gas isolating valves have been left off, lock-out should occur, indicated by power light only being illuminated and fan running.

Check the operation of the vacuum proving switch as follows: With the heater running normally, pull out the mains input connector. Pull off the silicone tube connecting the vacuum switch to the combustion chamber. Observe for at least 20 seconds that there is no attempt to re-ignite. Then replace the silicone tube.

Replace the safety control housing lid and re-connect the mains input connector.

To re-ignite each heater in the system, the fan must stop running. Switch system off at the control panel. Wait until fan stops completely and then restart system.

Repeat the above procedure for each of the heater units in the heating system.

#### **IMPORTANT**

When all the heaters have been commissioned as above, the vacuum settings must be finally balanced in the hot condition. Start all burners up and allow them to run for at least 20 minutes. With the use of a 'U' tube manometer determine vacuum reading at the damper assembly on each heater. See Fig. 5. for vacuum test point. The damper should be re-adjusted and set at a hot conditions reading as shown in Fig.12 for the appropriate size heater and model.

It will be noted that the emitter tube has a tendency to bow when hot, this is normal and quite acceptable.

## **5.0 CONTROL SYSTEMS.**

The control system must be installed in accordance with the design specification.

## 5.1 Control Panel Design

Ambi-Rad control panels are available either as standard units to control single or multiple zones of heaters utilising the Ambi-Rad Black Bulb radiant thermostat. Special control functions are available on request.

If a Herringbone control panel is used the following logic to operate in a safe and satisfactory manner is necessary:-

**Fig.13. Logic Sequence for Herringbone Control Panel.**

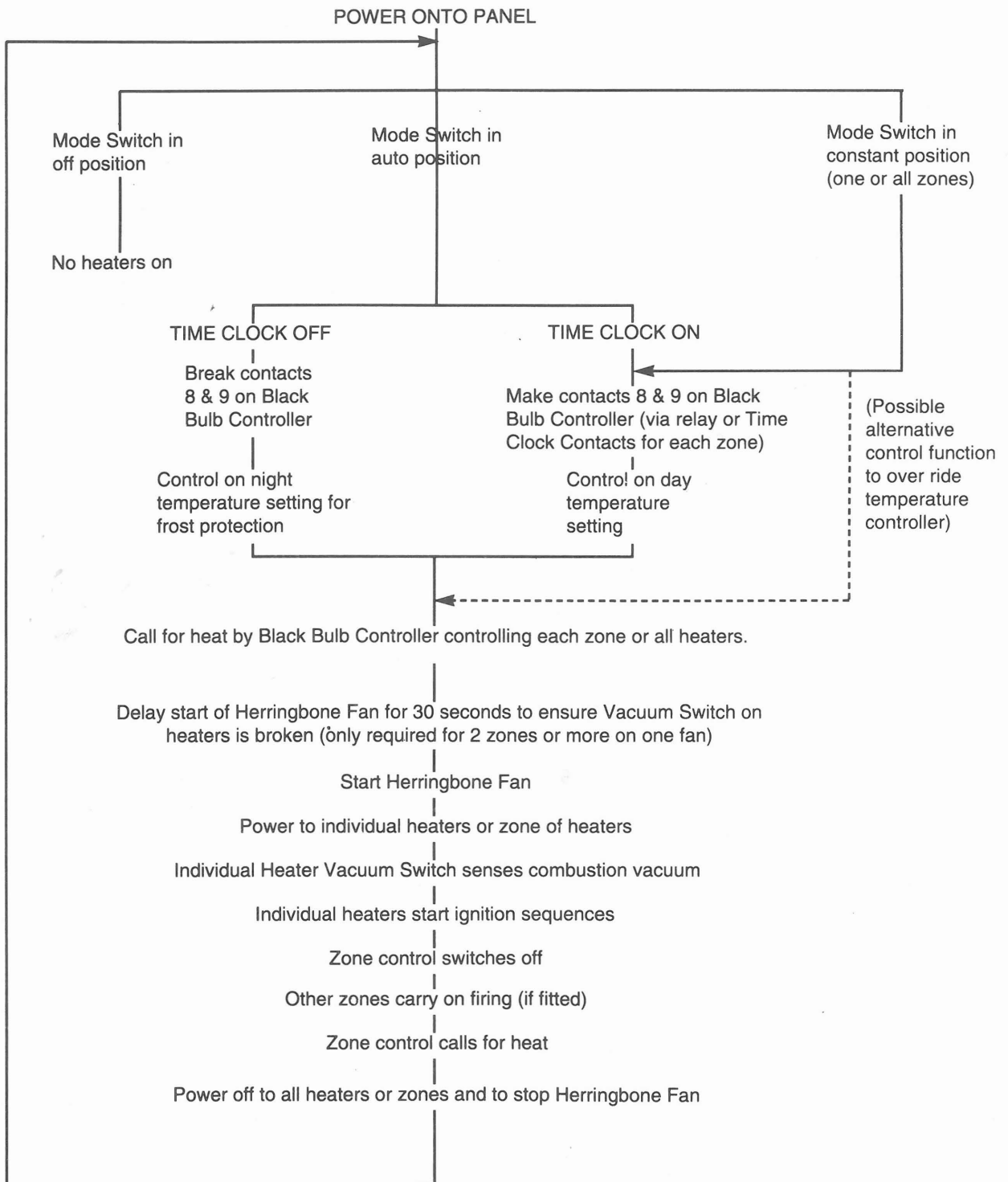

## 5.2 Installation of Control Panel

To Install the Ambi-Rad control panel remove the plastic plugs from the four 9mm diameter holes in the back of the control box. Using these holes fix the box in a convenient position to a suitable plugged wall or solid structure with No. 10 gauge woodscrews or 6mm diameter bolts or set screws. Access to the holes may be gained from the inside of the box without the necessity of removing the wiring chassis. Make the electrical connections in accordance with Fig.14 and cut holes in the removable gland plate provided in the box. Conduit or strain relief glands should be used.

**Fig.14a Herringbone Control Panel wiring diagram for Type 0 and Type 1 fans (single phase) incorporating the ARBB65 Black Bulb Control Thermostat.**

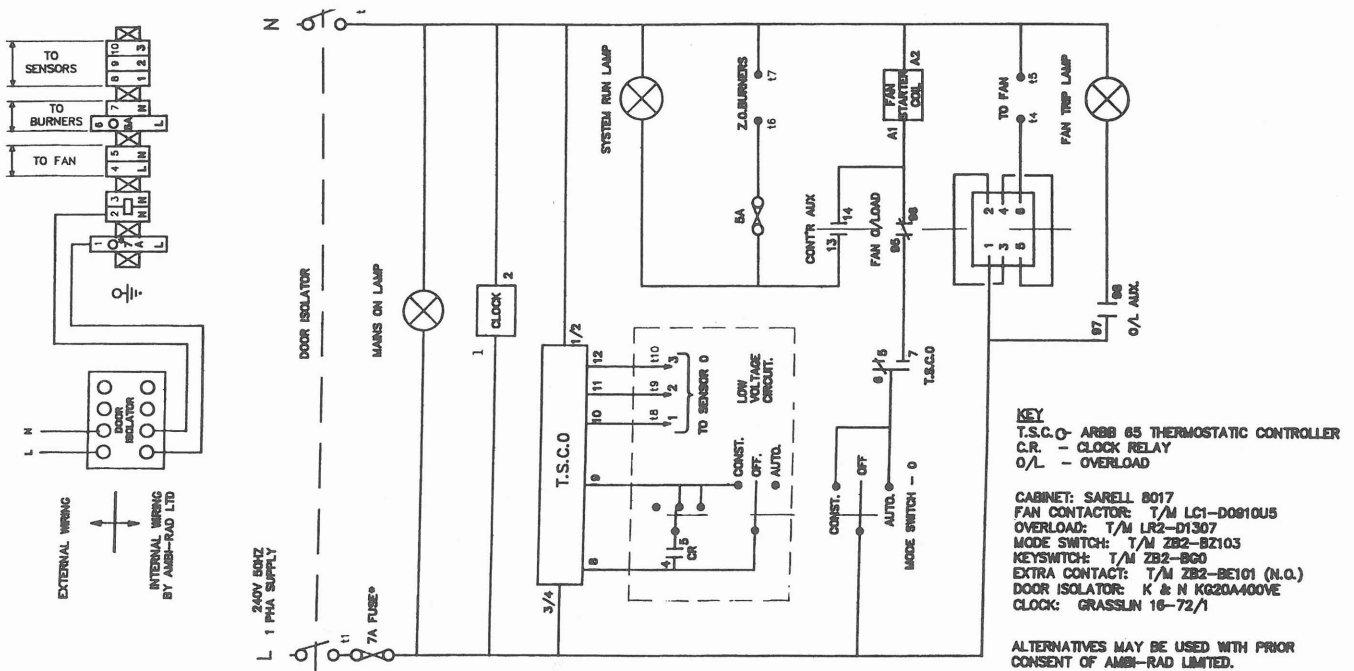

SET OVERLOAD RATING AT 1.8 AMPS (TYPE 1 FAN ONLY)  
SET OVERLOAD RATING AT 3.8 AMPS (TYPE 0 FAN ONLY)  
\*NOTE: FOR TYPE 0 FAN USE 10 AMP MAINS FUSE

**Fig.14b. Wiring diagram for Type 1 fan (three phase).**

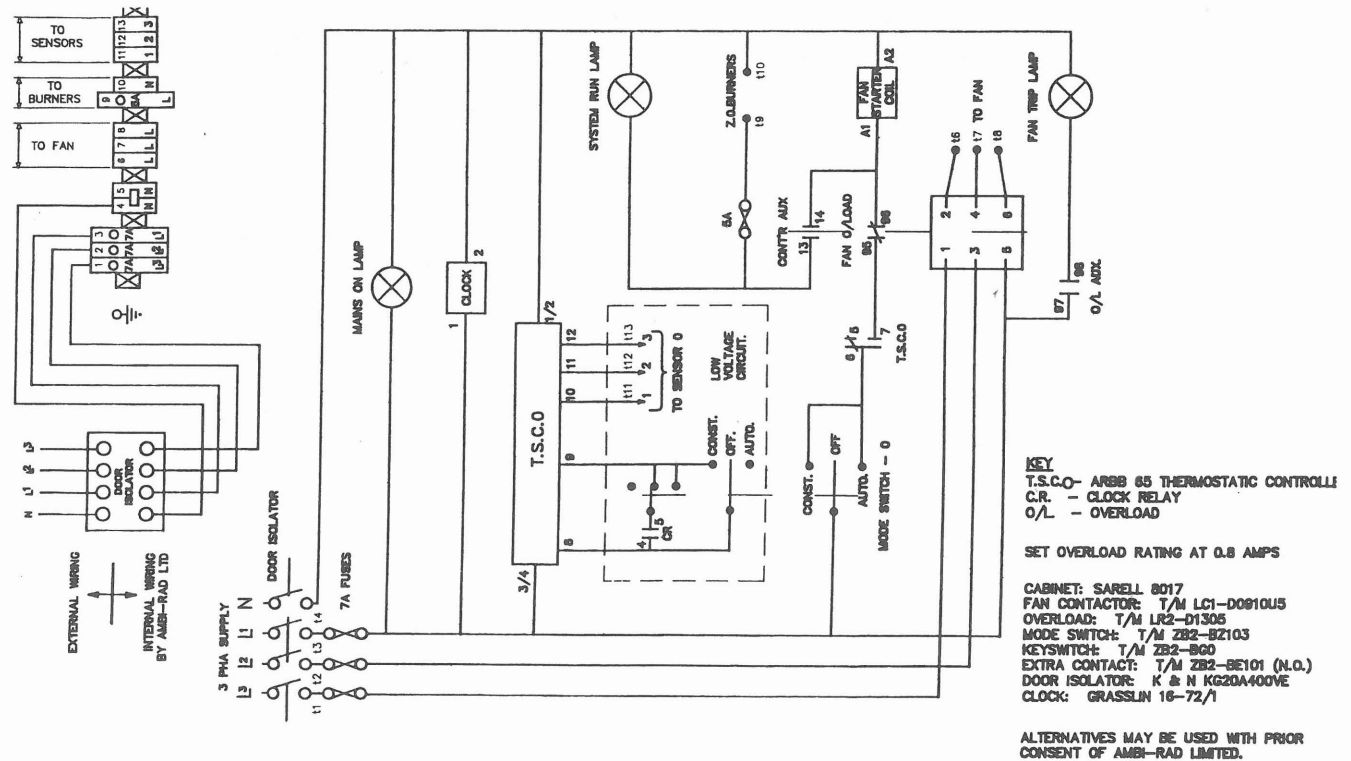
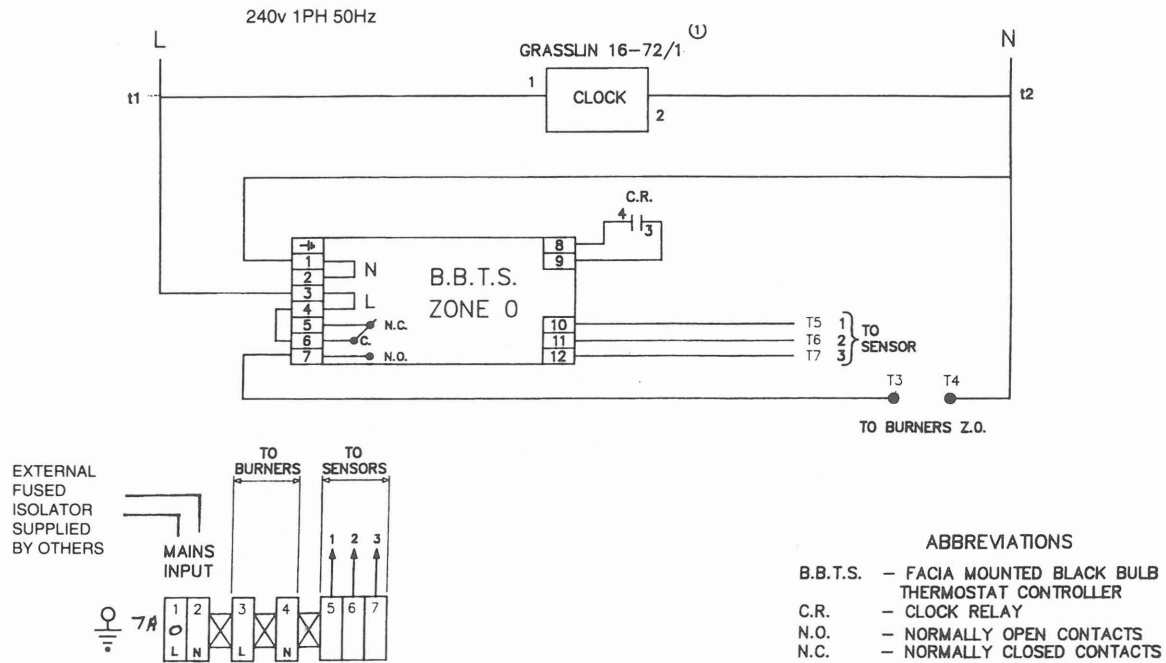

Fig.14c. Wiring diagram for Type 2 fan (single phase).



Vacuum fan characteristics.

FAN TYPE	POWER kW	RUNNING CURRENT A (overload rating)	PHASE	VOLTAGE V
'0'	550	3.8	Single	240
1	430	1.8	Single	240
1	250	0.8	Three	415
2*	120	0.8	Single	240

\*Overload not required.

5.3 Control Panel Timer and Black Bulb Thermostat Controller

The Grasslin 16/72/1 Digital Time Switch fitted to Ambi-Rad Control Panels should be set as follows:-

1. Check the main electricity supply is connected.
2. Use pencil or similar instrument, press reset button - After five seconds window displays 00:00.
3. Depress +/- button to advance time by 1 hour for British Summer Time. Depress once to cancel 1 hour advance.

TO SET DAY AND TIME

4. Depress  $\odot$  button continuously whilst setting day and time.
5. Depress day button until correct day appears in window.
6. To set time - depress h+ m+.
7. After setting day and time release  $\odot$  button. Clock will commence working after five seconds.

PROGRAMMING

8. Depress button CH1 - window will display....
9. Depress day button to set "on" days required.
  - (a) Press once for 7 day display.
  - (b) Press again for 5 day display.

- (c) Press again for Sat. and Sun only.
- (d) Press again for individual days.
10. To set switching "on" times to suit day programme depress h+ m+ button.
11. To lock in the "on" programme - depress CH1 button.
12. To set switching "off" time depress CH1 button.
13. Depress day button to set "off" days required.
14. Using buttons h+ m+ set switching "off" days required.
15. To lock in the "off" programme depress CH1 button.
16. After setting "on-off" programme, depress button  $\odot$  to reinstate day and time window.
17. To manually override programme, depress  $\triangle$  1 button - "on" or "off" will be displayed in window.

**NOTE: If buttons h+ m+ are depressed for longer than 2 seconds rapid advance will take place. FOR FULL OPERATING INSTRUCTIONS REFER TO MANUFACTURER'S OPERATING INSTRUCTIONS.**

**Fig.15. Time Switch and Facia Mounted Black Bulb Controller**

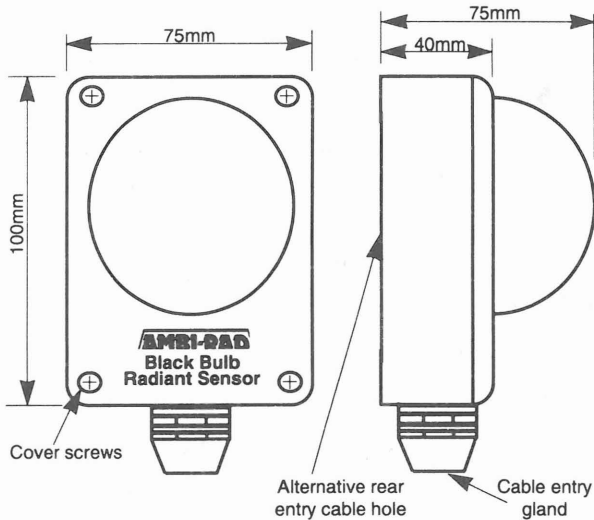
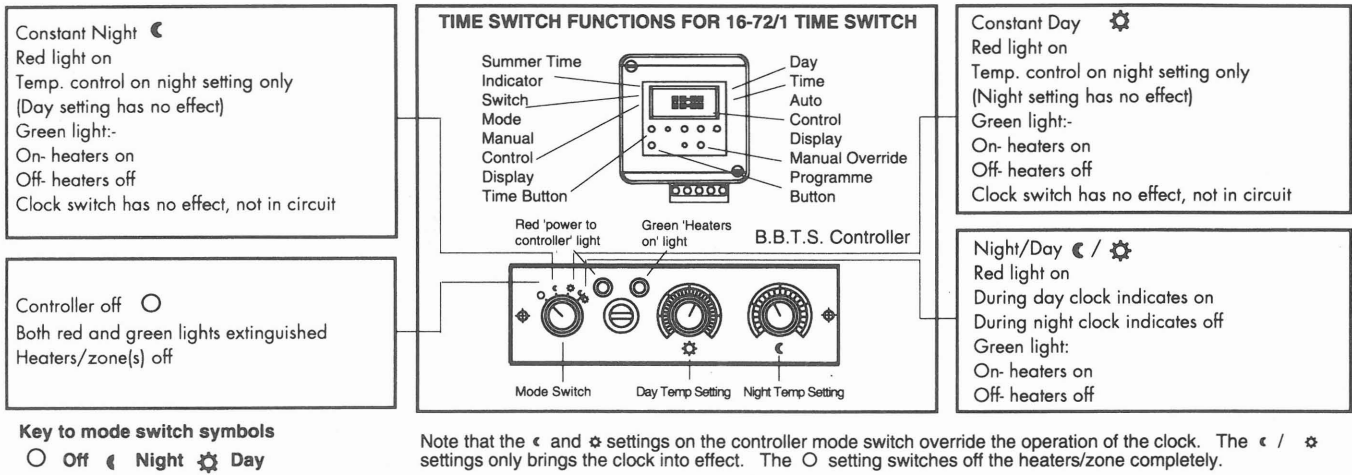

**Fig.16. Sensor Unit.**

**Instructions for fixing Sensor unit.**

1. A position should be selected 1.5m from the floor where the sensor will be free from undue draughts and if necessary between 4 and 5m from one of the heaters to be controlled. Avoid placing the sensor where it will be in an area shadowed from radiant heat (behind racking etc.).
2. Remove the cover of the sensor unit by undoing the four screws.
3. Fix the base to the wall with two screws.
4. Connect the sensor using a three core cable of not less than 0.5mm<sup>2</sup>. Maximum length of cable is 200m if 0.5mm<sup>2</sup> is used. Secure wires in the cable gland provided (alternative rear cable entry available - remove gland and seal with grommet if rear entry used).
5. Wire sensor to controller in accordance with wiring diagram. See section (5).
6. Refit the sensor to the base.

**5.3 Fan Starter Overload**

The red "reset" button on the fan starter is used only to restart the fan should it cut out due to overload or malfunction. Should repeated lock-out occur, then a qualified electrician should be consulted.

**6.0 SERVICE INSTRUCTIONS**

Under normal working conditions, it is recommended that the Ambi-Rad heater has a routine service once per year. In exceptionally dirty or dusty conditions, more frequent servicing may be desirable. Servicing work should be carried out by a qualified gas servicing engineer.

For heater routine service, trouble shooting checklist and spares list, please refer to the appropriate ER, AR or RB heater model section.

NOTES

## USER INSTRUCTIONS FOR AMBI-RAD HERRINGBONE HEATERS.

AMBI-RAD is an overhead radiant heating system for industrial and commercial buildings. The AMBI-RAD heater is suspended horizontally overhead from the roof or inclined mounted and heats by radiation in the same way as the sun.

### IMPORTANT

- 1 This appliance must only be installed by a competent person in accordance with the requirements of the Gas Safety (Installation & Use) Regulations 1984 (as amended) and the Health and Safety at Work etc. Act 1974.
- 2 **WARNING: THIS APPLIANCE MUST BE EARTHED.**
- 3 Never rest anything, especially ladders, against the heater.

To start the AMBI-RAD heater:

- 1 First ensure that the gas supply to the heater is turned on.
- 2 Ensure that the settings of any time-switch and thermostat are such that the heating system will be required to operate.
- 3 Switch on electrical supply to heater. Mains light, coloured red, will illuminate and ignition sequence will commence.
- 4 After completion of an air purge period, ignition of the burner will occur and burner light, amber, will illuminate.
- 5 If ignition attempt fails, burner sequence controller will lock out with mains light only illuminated.
- 6 If lock out occurs switch off electrical supply, wait 15 seconds then switch on again. If lock out occurs again switch off heater and call service engineer.

N.B. Heater will have tendency to bow when hot, but this is quite acceptable.

To switch off AMBI-RAD heater.

Switch off electrical supply to the heater. The burner will shut off and the fan will stop.

If the heater is switched off for periods in excess of one week it is highly recommended that both gas and electrical supplies are turned off.

### Servicing:

To ensure continued efficient and safe operation it is recommended that the heater is serviced regularly by a competent person, e.g., every year in normal working conditions but in exceptionally dusty or polluted conditions more frequent servicing may be required. The manufacturer, whose address is given below, offers a maintenance service. Details available on request.

**AMBI-RAD**  
radiant heating systems

P.O. Box 30, Enfield Works,  
Mucklow Hill, Halesowen, West Midlands.  
B62 8DS  
Tel: 021 503 0707. Fax: 021 501 2955

Because of our policy of continuous development Ambi-Rad limited reserves the right to vary the equipment specification without notice.