

# The Ambi-Rad Mid Range Heater

AMBI-RAD produces a range of overhead heating systems designed for industrial, commercial and other large buildings. Heaters are mounted at high level, suspended from chains or wall brackets and are available in various thermal ratings and configurations.

The ER22 heater incorporates a pair of parallel radiant emitter tubes, connected together at one end by a "U" bend. A gas burner fires into the open end of one tube and hot combustion gases are drawn through the tubes by a vacuum fan mounted on the exit end of the second tube. The tubes become hot and emit infra red radiant heat. A stainless steel reflector supported above the tubes directs the radiant heat downwards towards the lower, occupied levels of the building.

The firing and return tubes are of mild steel and are supported in adjustable suspension brackets. The reflectors are of highly polished stainless steel for long life, are easily detachable for cleaning, as and when required. They are mounted in the suspension brackets in such a way as to permit free thermal expansion.

The burner assembly is mounted on the firing leg of the heater and incorporates two compartments. There is a combustion chamber in which are located the burner and the ignition and flame sensing

electrode assembly. Attached to the combustion chamber is a totally enclosed housing which contains the burner control components including the gas safety shut off valve, gas pressure regulator, electronic sequence controller, vacuum proving switch and its checking relay. The vacuum switch monitors vacuum conditions via an impulse line from the combustion chamber.

As the safety control housing is an enclosed compartment all safety controls and electronic components are protected from contamination from airborne dust and fumes commonly found in industrial environments.

A high efficiency centrifugal vacuum fan is mounted on the exit

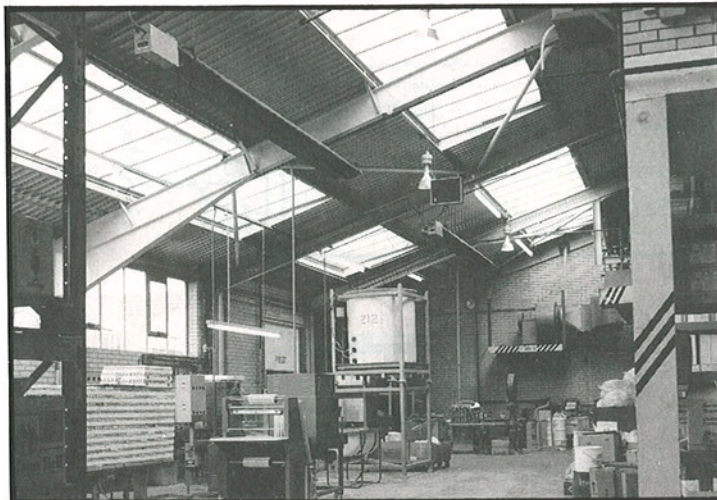

of the return leg of the heater. The motor is housed in an aluminium shroud, has thermal overload protection, a shaft mounted cooling impeller and pre-lubrication long life bearings. It has a plug-in electrical connection and is easily detachable for inspection and cleaning.

## OPERATION

When an electrical supply is switched on to the heater(s) either manually or via a time switch or thermostat, automatic start up occurs. The "mains on" indicator light is illuminated and power is supplied to the vacuum fan. The fan runs up to speed and a vacuum condition is created throughout the emitter tube system and combustion chamber.

When the correct vacuum condition is detected by the vacuum

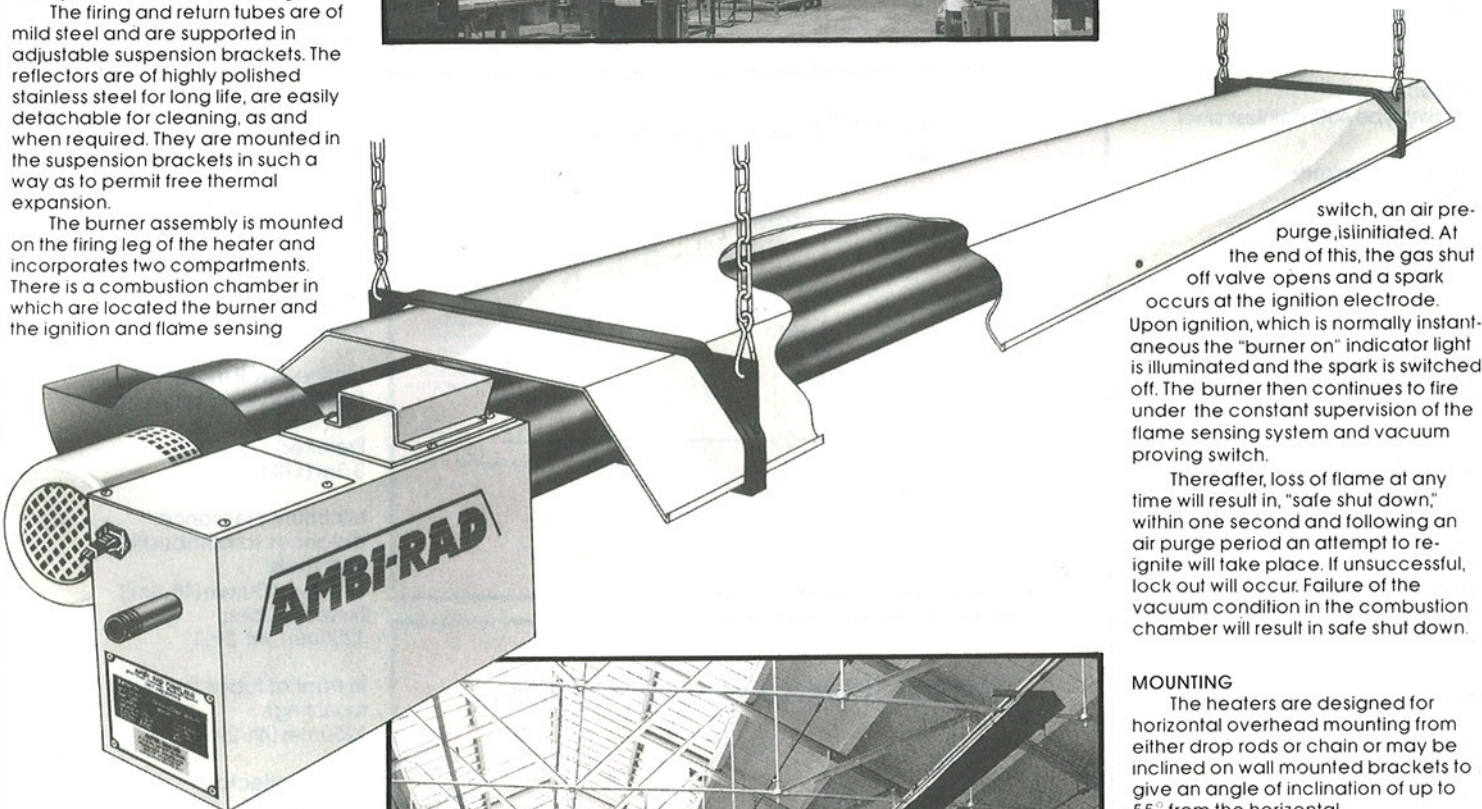

switch, an air pre-purge is initiated. At the end of this, the gas shut off valve opens and a spark occurs at the ignition electrode. Upon ignition, which is normally instantaneous the "burner on" indicator light is illuminated and the spark is switched off. The burner then continues to fire under the constant supervision of the flame sensing system and vacuum proving switch.

Thereafter, loss of flame at any time will result in, "safe shut down," within one second and following an air purge period an attempt to re-ignite will take place. If unsuccessful, lock out will occur. Failure of the vacuum condition in the combustion chamber will result in safe shut down.

## MOUNTING

The heaters are designed for horizontal overhead mounting from either drop rods or chain or may be inclined on wall mounted brackets to give an angle of inclination of up to 55° from the horizontal.

The heaters may be installed with or without flues to atmosphere providing the preceding criteria given are complied with. Where heaters are required to be fitted with a flue, an optionally available down draught diverter must be fitted to the vacuum fan outlet. The diverter is designed to accept a 125mm (5") nominal bore twin wall flue to BS 715. Maximum length of flue is 9m (30ft) with a maximum of two bends.

When the heater is to be installed in locations where there is airborne dust or a polluted atmosphere a ducted fresh air supply may be provided to the combustion chamber. Maximum length of fresh air duct is 7m (23ft) with a maximum of two bends.

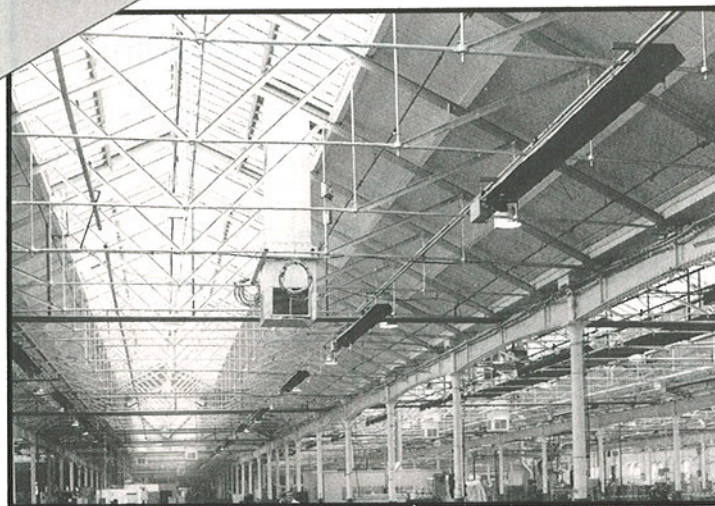

# MODEL ER22

# Technical Data and Specification

**Heat input:**  
22kW (75,000 Btu/hr)

**Combustion efficiency:**  
80-84%

**Combustion air intake (optional)**  
100mm (4in.) dia.

**Exhaust flue (optional)**  
125mm (5in.) twin wall

**Ignition:**  
Electronic programmed start up with spark ignition.

**Emitter tubes (outside dia.):**  
76mm (3in.)  
gauge 3.65mm (0.144in.)

**Reflector:**  
22 swg type 430 stainless steel

**Support brackets:**  
Mild steel

**Total weight**  
92 Kg (202.8lb.)

**Natural ventilation requirements:**  
Minimum unobstructed permanent area to external air.

**Unflued heaters:**  
Low level ventilation: Where A/C rate is below 37.5m<sup>3</sup>/hr/kW of total heat input additional low level ventilation to be provided as follows:  
a) 1.4cm<sup>2</sup>/1m<sup>3</sup>/hr/kW below 37.5m<sup>3</sup>/hr/kW or b) 52cm<sup>2</sup>/kW of total rated heat input.

**High level ventilation to be provided preferably above personnel working positions as follows:**  
Up to and including 60kW, 4.5cm<sup>2</sup>/kW; over 60kW, 270cm<sup>2</sup> plus 2.25cm<sup>2</sup>/kW in excess of 60kW total heat input.

**Flued heaters:**  
Ventilation openings shall be provided preferable at low level as follows:  
Up to and including 60kW, 4.5cm<sup>2</sup>/kW; over 60kW, 270cm<sup>2</sup> plus 2.25cm<sup>2</sup>/kW in excess of 60kW total rated heat input.

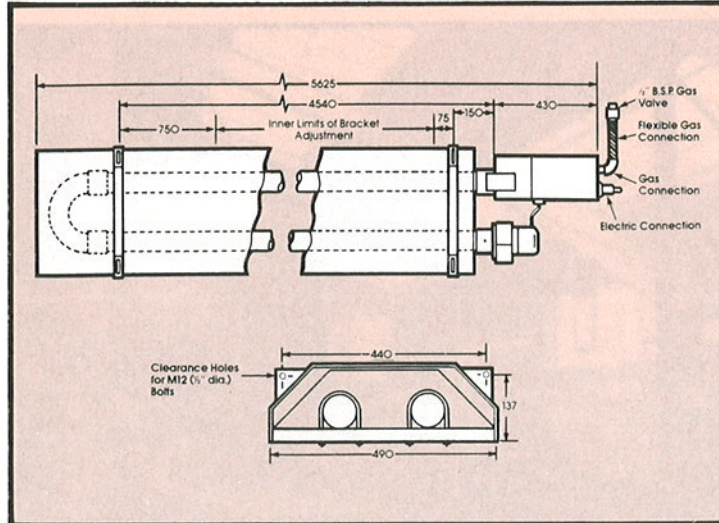

**Gas supply connection:**  
R $\frac{1}{2}$  (1/2in. B.S.P external thread)

**Electrical supply:**  
240v, 1 phase, 50Hz

**Current rating:**  
0.33 amp max. (inductive)

**Internal fuse rating:**  
1 amp

**Injector size:**  
Nat. Gas 4.1mm (0.161in.)  
Propane 2.4mm (0.945in.)

**Maximum supply pressure:**  
Nat. Gas 40mbar (16in. w.g.)  
Propane 40mbar (16in. w.g.)

**Minimum supply pressure:**  
Nat. Gas 13mbar (5in. w.g.)  
Propane 30mbar (12in. w.g.)

**Burner setting pressure:**  
Nat. Gas 10.6mbar (4.2in. w.g.)  
Propane 28.75mbar (11.5in. w.g.)

**Mounting heights:**  
**Over head horizontal**  
Recommended minimum 3.6m (12ft.)  
Preferred 4.2m (14ft.)

**Inclined wall mounted:**  
Recommended minimum 3m (10ft.)  
Preferred 3.3m (11ft.)

**Minimum clearance:**  
distances to combustible materials:  
To sides: 500mm (1ft. 8in.)  
Beneath tubes: 1250mm (4ft. 2in.)

**In front of tubes (inclined mounting):**  
1250mm (4ft. 2in.)

**Above reflector:**  
100mm (4in.)

**Above burner/fan:**  
400mm (1ft. 4in.) if heater unflued  
200mm (8in) if heater flued

GC Approval No. 36 229 01

**For full assembly, installation and commissioning instructions please ask for our publication AR883.**

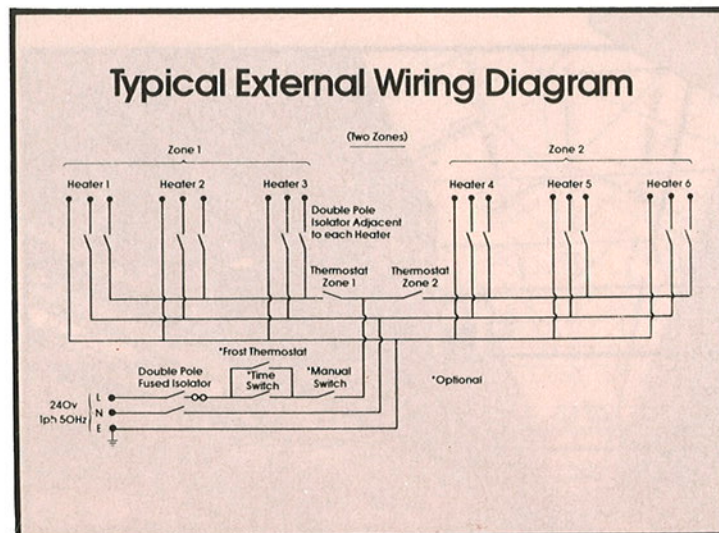
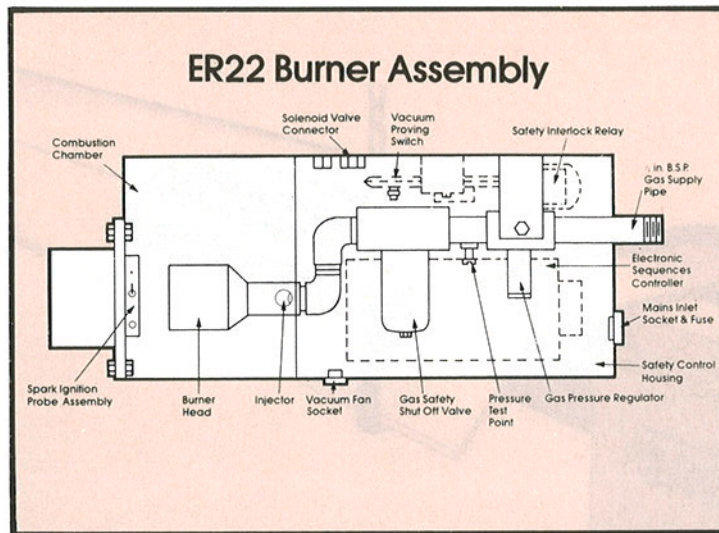

Because of our policy of continuous development Ambi-Rad Ltd. reserve the right to vary the equipment specification without notice.

# AMBI-RAD<sup>®</sup>

## radiant heating systems

London Office:  
Unit 24, Rosemary Road,  
Swan Industrial Centre, Wandsworth,  
London SW17 0AR.  
Tel: 01-879 3161. Fax: 01-879 0457.

Head Office:  
PO Box 30, Enfield Works, Mucklow Hill,  
Halesowen, West Midlands B62 8DS.  
Tel: 021-503 0707. Telex: 333003 AMBI-G.  
Fax: 021-501 2955.

Northern Office:  
Unit 35, Offerton Industrial Estate,  
Hempshaw Lane, Offerton, Stockport,  
Cheshire SK2 5TJ.  
Tel: 061-429 6066. Fax: 061-429 9606.

AMBI-RAD is the registered trade mark of AMBI-RAD LTD.