

ASSEMBLY INSTRUCTIONS FOR MODELS : ER13SL/HB13, ER22SL/HB22, ER38SL/HB38

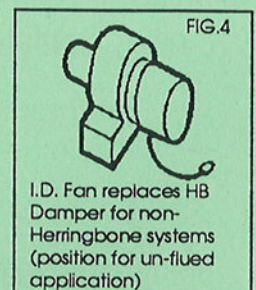
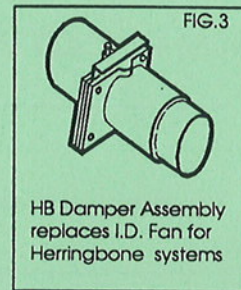
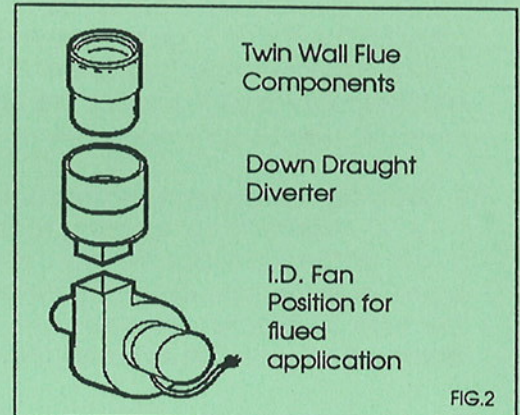
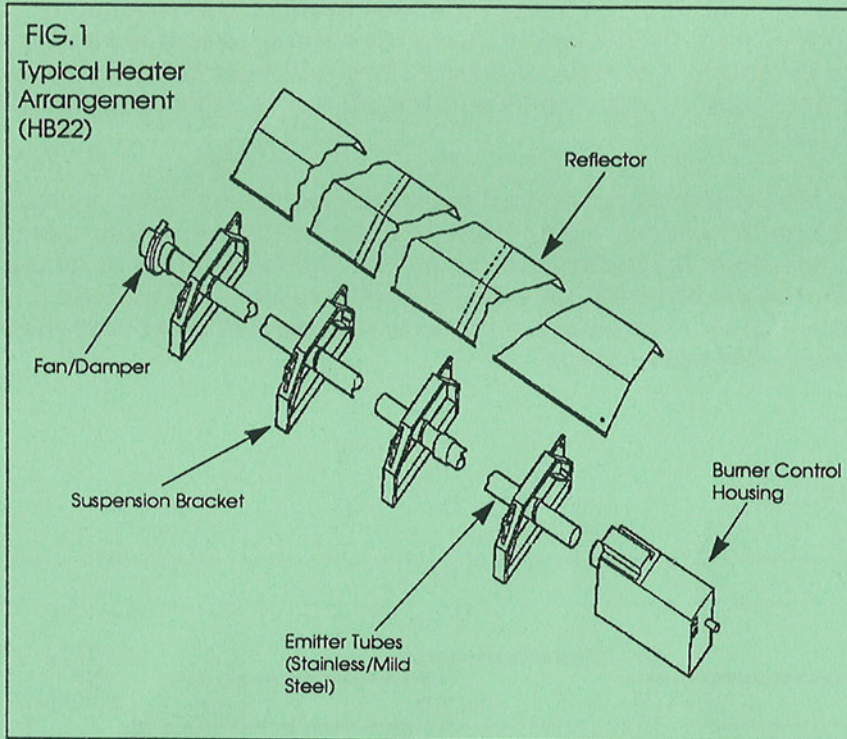

TECHNICAL DATA & CONTENTS

MODEL		ER13SL/HB13	ER22SL/HB22	ER38SL/HB38
Heat Input		13kw (44,400Btu/h)	22kw (75,000Btu/h)	38kw (130,000Btu/h)
Nominal Gas	(nat gas)	43 cu.ft./h (1.2 cu.m/h)	73 cu.ft./h (2.1 cu.m/h)	126 cu.ft./h (3.6 cu.m/h)
	(propane)	17.7 cu.ft./h (0.5 cu.m/h)	30 cu.ft./h (0.85 cu.m/h)	52 cu.ft./h (1.47 cu.m/h)
Gas Supply Connection		Rc 1/2 (1/2in B.S.P. external taper)		
Electrical Supply		240v 1 phase 50hz		
Internal Fuse Rating		1A		
Current Rating		0.55 max. inductive (HB models 0.04A + main fan current)		
Ignition		Electronic Programme Start-Up with spark ignition		
Total Installed Weight		55kg	92kg	110kg
Exhaust Flue (optional)		100mm (4in.) dia.	125mm (5in.) dia.	125mm (5in.) dia.
Burner Assembly		1 qty.	1 qty.	1 qty.
Induced Draught Fan		ER13SL only	ER22SL only	ER38SL only
Damper Assembly		HB13 only	HB22 only	HB38 only
Stainless Steel Tube		No	1 qty. 2m long x76mm dia.	1 qty. 1.75m long x100mm dia.
Mild Steel Tube		1 qty. 6.1m long x 63mm dia.	1 qty. 5.5m long x76mm dia.	2 qty. 5.3m long x100mm dia.
Suspension Brackets		1 type 'A', 2 type 'B'	2 type 'A', 2 type 'B'	3 type 'A', 2 type 'B'
Stainless Steel Reflectors		2 qty.	3 qty.	4 qty.
Electrical Flying Lead		1 qty.	1 qty.	1 qty.
Sundry Items		Chain, Nuts, Bolts, Washers etc.		

HB ACCESSORIES

1 HB Type 1 Fan. Single phase standard. (Three phase available upon request).

1 Manifold kit to individual specification; kit includes aluminium manifold tubing, manifold tees, connectors, bends etc.

1 Jointing compound gun and a quantity of silicon sealant.

1 Square to round exhaust flue transition piece (rectangular telescopic wall flue available upon request).

ASSEMBLY INSTRUCTIONS FOR ER13SL/HB13, ER22SL/HB22, ER38SL/HB38

1. Support radiant tube(s) on blocks, trestle etc. at least 250mm (6in) above floor level, preferably under position of installation. Ensure tubes are clear internally.
2. Where supplied (ER22SL, HB22 and ER38SL, HB38) bolt the stainless steel tube to the mild steel tube(s) ensuring the stainless steel section is at the burner end of the heater. The tube sections are attached to each other by means of 2 "grub" screws and locking nuts. **(NOTE: Do not over tighten the grub screws into the mild steel tube, finger tight is sufficient to allow for thermal expansion but the locking nuts must be tightened with a spanner.)** When all the tubes are connected together, turn the tube assembly so the collar screws and nuts are facing left to right when viewed from the top.
3. Slide the suspension brackets onto the tube assembly noting that there are two distinct types of brackets, type "A" with reflector locating tabs and type "B", without. (fig.6) These must be fitted alternately along the length of the tube assembly as shown in fig5 **Note: These positions are critical. Tighten the nuts to secure the brackets to the tube assembly ensuring that all the brackets have the same orientation, i.e. horizontal. The type 'A' bracket located on the stainless steel tube adjacent to the burner must be fitted with the long threaded "U" bolt with stop nuts (Fig. 7) and clamped in position.**

FIG.5 SUSPENSION BRACKET LOCATION

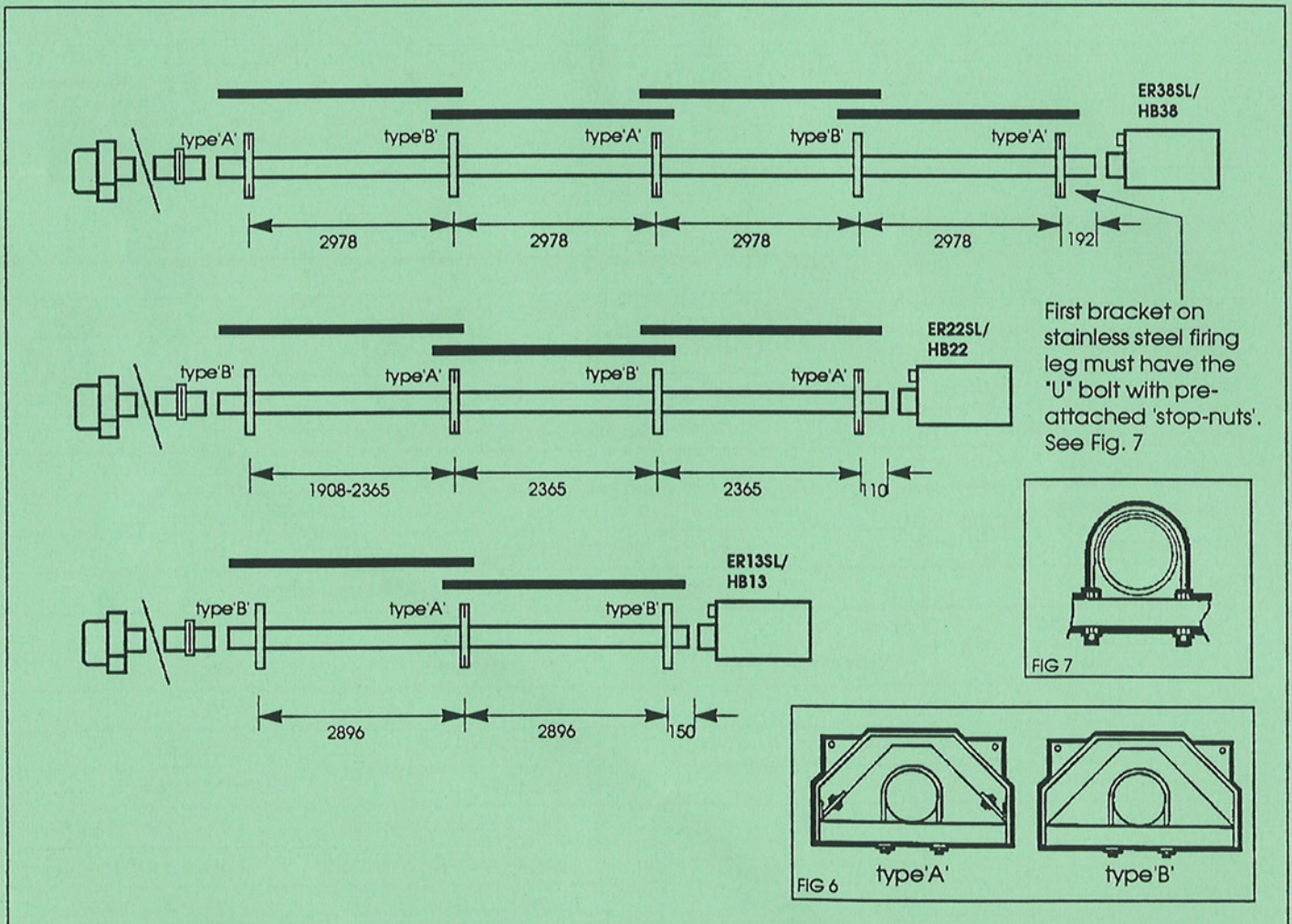

INSTALLATION

We recommend that at this stage the tube assembly is raised into position and suspended by all suspension brackets from previously fixed chains of 4mm gauge galvanised welded link construction or fixed to two wall mounting brackets which must incorporate a short section of hanging chain to allow movement due to thermal expansion. Alternatively 10mm diameter mild steel drop rods can be used. Wall mounting brackets must support the heater at an angle of inclination of between 35 and 55 degrees and are available from the manufacturer. The angle is varied by adjusting the chain on each bracket.

NOTE: If the heater is to be wall mounted the burner assembly must be on the right-hand side when viewed facing the wall. A 90 degree bend must be fitted to the fan to discharge products of combustion horizontally away from the heater.

SUGESTED METHODS OF HEATER SUSPENSION

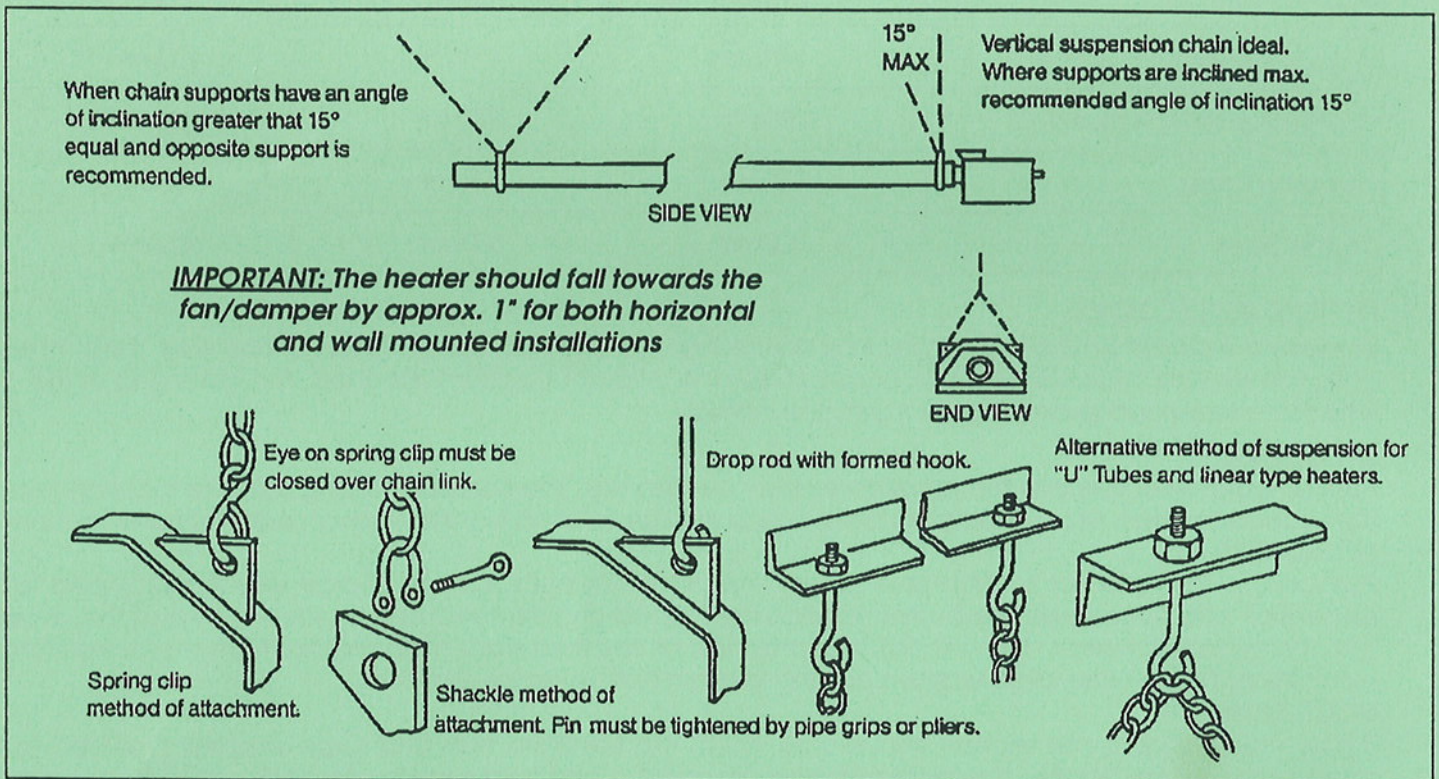

Attachment to the heater bracket support lugs should be made by either a spring hook, "D" shackle, nut bolt and large washers, or in the case of drop rods, a formed hook and due allowance must be made for thermal expansion of the heater.

The hanging attachments to overhead steelwork etc. must be purpose made to good sound engineering practice or of a proprietary type fixing.

They must be adequately fixed and designed to carry the whole weight of the heater and to permit free movement due to linear expansion.

In the event of suitable roof steelwork not being available, additional steelwork should be fitted to enable vertical hangers to be used for suspending the heaters.

If there is any doubts as to the strength or suitability of roof steelwork to which heaters are to be suspended, please refer to consultant/architect/ owner of the building.

The recommended minimum and preferred mounting heights for the AMBI-RAD heaters are as follows:

MODEL	MOUNTING POSITION	MINIMUM MOUNTING HEIGHT	RECOMMENDED MOUNTING HEIGHT	WHEN MOUNTING OVER THESE HEIGHTS CONTACT AMBI-RAD DESIGN OFFICE
ER13SL/HB13	HORIZONTAL	3.0m	3.6m-6.0m	over 4.5m
ER13SL/HB13	WALL MOUNTED	2.7m	3.0m-4.0m	
ER22SL/HB22	HORIZONTAL	3.6m	4.2m-14m	over 7.0m
ER22SL/HB22	WALL MOUNTED	3.0	3.3m-5.5m	
ER38SL/HB38	HORIZONTAL	4.3m	4.9m-25m	over 11.0m
ER38SL/HB38	WALL MOUNTED	3.6m	4.0m-7.0m	

The proposed position of the heater should be selected so that the clearance distances to combustible materials will be ensured. These are tabulated overleaf.

MINIMUM CLEARANCE DISTANCES

Model	ER13SL/HB13	ER22SL/HB22	ER38SL/HB38
Above Reflector	100mm	100mm	100mm
Above Burner/Fan (unflued)	300mm	400mm	400mm
Above Burner/Fan (flued)	200mm	200mm	400mm
Beneath Tubes	900mm	1250mm	1500mm
To The Sides	300mm	500mm	500mm

FITTING REFLECTORS

Remove the plastic film from the reflectors. Notice that the reflectors are punched at one end. These holes coincide with the Type A suspension brackets with the reflector locating tabs fitted. The other end of the reflector is free-floating allowing for thermal expansion.

ER13SL/HB13

Position both reflectors into the brackets so they overlap with the holes coinciding with the locating tabs on the second bracket. Secure using M6 bolts, nuts and large washers passing through both reflector sections.

ER22SL/HB22

Position the first reflector section and secure it with the M6 bolts, nuts and large washers provided to the suspension bracket nearest the burner. Position the second and third sections of reflector so that they overlap with the punched holes in line with the lugs provided on the third suspension bracket from the burner. Secure using M6 bolts, nuts and large washers passing through both reflector sections.

ER38SL/HB38

Position the first reflector section and secure it with the M6 bolts, nuts and large washers provided to the suspension bracket nearest the burner. Position the second and third section of reflector so that they overlap with the punched holes in line with the lugs provided on the third suspension bracket from the burner. Position the fourth reflector in the fourth bracket, and attach the reflector to the fifth bracket. Secure using M6 bolts, nuts and large washers passing through both reflector sections where appropriate.

BURNER/FAN/DAMPER ASSEMBLY

Slide the burner/control assembly onto the tube assembly (with 22kw and 38kw models the burner assembly must be fitted to the stainless steel section), ensuring it is fully engaged and whilst holding burner assembly horizontal secure with pinch screws provided.

Slide fan/damper assembly onto the other end of the tube ensuring it is fully engaged. ***The fan discharge outlet should face vertically upwards, if heater is to be individually flued or horizontally if unflued. Using the junction box kit connect the burner to the fan assembly NOTE: The installer to provide cable between burner/fan. Where the damper assembly is fitted the damper blade must be in the vertical plane.*** Secure with pinch screw.

FLUE CONNECTION (ER13SL, ER22SL, ER38SL)

The Ambi-Rad heater may be installed with or without a flue to atmosphere providing the air supply and building ventilation requirements as stated in BS 6896:1991 are complied with.

If the heater is installed without a flue, ensure that combustion gases do not impinge on combustible materials. The maximum permitted temperature for such materials is 65C (BS.3561). When unflued due consideration must be given to the possibility of condensation forming on cold surfaces.

If the heater is to be installed with a flue a down draught diverter (supplied as an optional extra) must be fitted to the induced draught fan exit by means of the screws and clamps provided.

The flue construction should be adequately supported at regular intervals from the building structure and terminated externally with a British Gas Tested and Certified terminal. The maximum flue length is 9m and maximum number of bends is two. All connections in the flue pipe must be properly sealed.

**FOR GAS CONNECTION, COMMISSIONING, ELECTRICAL DETAILS AND SERVICING SEE PUBLICATION:
USER INSTALLATION AND SERVICING MANUAL**



Ambi-Rad Limited, P.O. Box 30, Enfield Works,
Mucklow Hill, Halesowen, West Midlands, B62 8DS.
Tel: 021-503 0707. Fax: 021-501 2955.