

AMBIRAD

ENERGY EFFICIENT HEATING SYSTEMS

ARO SERIES

OIL FIRED
TUBE HEATER

Installation and
operating manual



Index

- 1** Commissioning, service and warranty
- 2** Health and safety
- 3** Electrical installation
- 4** Heater suspension & mounting heights
- 5** Clearance distance to combustible surfaces
- 6** Heater assembly
- 7** Flue details
- 8** Ventilation requirements
- 9** Ducted air for polluted/dusty atmospheres
- 10** Oil type and supply details
- 11** Routine servicing and fault finding
- 12** Replacement of parts
- 13** Parts: Spares and installation



1 Commissioning, service and warranty

Commissioning

After installation in accordance with these instructions please contact Ambi-Rad Service on 01384 489700 to arrange commissioning of the product.

Note Failure to observe the above will invalidate the warranty.

Service

To ensure continued and safe operation it is recommended that the heater is serviced every 6 months.

The manufacturer, whose address is provided at the back of these instructions, offers a maintenance service. Details available on request.

Warranty

All parts and labour are covered for a period of 12 months from the date of commissioning. Any consumable parts such as the burner nozzle used on routine service are excluded from the warranty.

Please contact Ambi-Rad Service on 01384 489700 for further details.

2 Health & safety

Sole liability rests with the installer to ensure that all site safety procedures are adhered to during installation.

Sole liability rests with the installer to ensure that protective safety wear such as hand, eye, ear and head protection is used during installation of the product.

Direct contact with oils or insulation without the use of safety protection must be avoided.

Do not rest anything, especially ladders against the heater.

All installations must be in accordance with the regulations in force in the country of use.

Installers must be able to demonstrate competence and be suitably qualified in accordance with the regulations in force in the country of use.

These instructions must be given to the user on completion of the installation.

3 Electrical installation

Ensure the burner has a permanent live supply in addition to the switch live supply.

This appliance must be earthed.

Electrical supply must be via a fused double pole isolator having a contact separation of >3mm in all poles. The installation shall conform to the regulation in force in the country of use.

Switching and control is recommended on the live conductor.

Supply 230V 50Hz single phase.

Current rating 0.7 amp max (inductive).

Fuse rating 5 amp per heater.

The plug supplied with the burner must be wired as shown in the wiring diagram. (See Fig 1 page 2).

For economic control of the heater(s) the installation of a black bulb thermostat is recommended and available from the manufacturer.

Remote reset of control box is possible via a momentary switch that is available from the manufacturer.

Figure 1 Wiring diagram

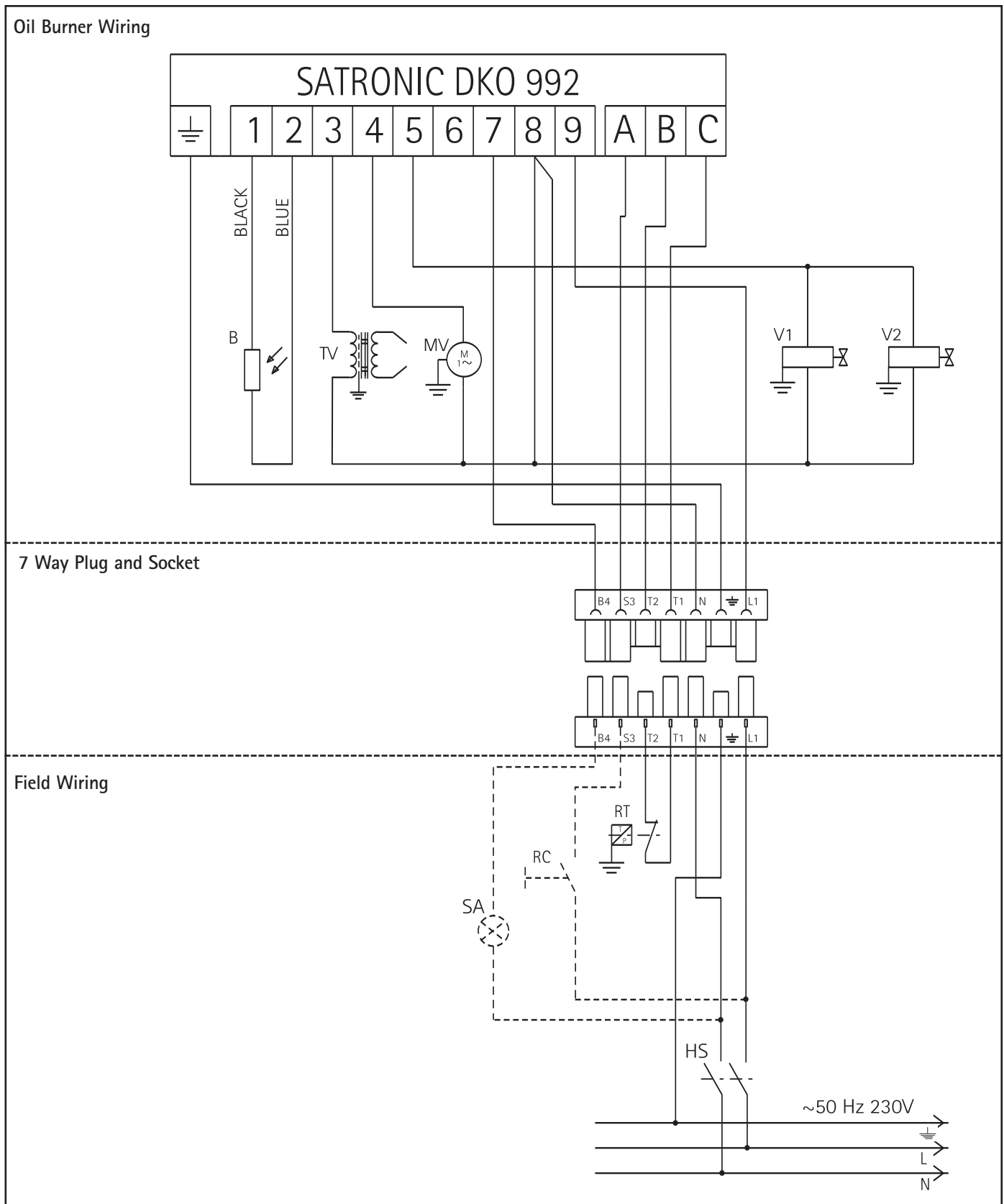

- B Photo resistor
- TV Transformer - ignition
- MV Burner motor
- V1 Oil solenoid valve
- V2 Extra safety oil solenoid valve

- SA External lockout lamp (optional)
- RC External reset lockout (optional)
(AR Part No 200159)
- RT Control thermostat
- HS Mains switch

4 Heater suspension and mounting heights

The weight of the heater is approx. 100kg.

Attachment of the heater support brackets to the building structure must be made using 4mm welded link chain and speed links. Alternatively 10mm diameter closed loop drop rods.

The U Tube heater must be suspended from a minimum of 2 support brackets. First and third brackets from the burner end or first and forth. See Table 2/Fig 2.

It is the sole responsibility of the installer to ensure that the points of attachment to the building are sound. Consultation with the consultant/architect or owner of the building is recommended to ensure that a sound, mechanically stable installation is achieved.

Please refer to diagram and tables on this page.

Table 2

Required angle	60°	45°	30°
Chain length	2 links,	18 links,	15 links
Eye bolt position	3 U Tube		

All dimensions in mm.

5 Clearance distance to combustible surface

Figure 4

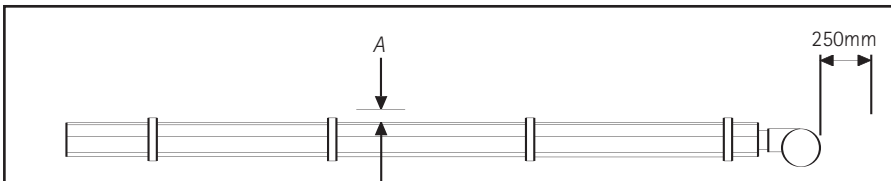

Table 3 Clearance distances

		All models
Above reflector	A	420
Beneath tubes	C	2300
To the sides	D	1480

All dimensions in mm.

Table 1 Mounting heights from floor

Model	ARO40	
	Horizontal	Inclined/wall
Minimum mounting height	4000	3600
Recommended mounting height range	4900 - 11000	4000 - 7000
When mounting over these heights contact Ambi-Rad Design office	Over 11000	Over 7000

Figure 2

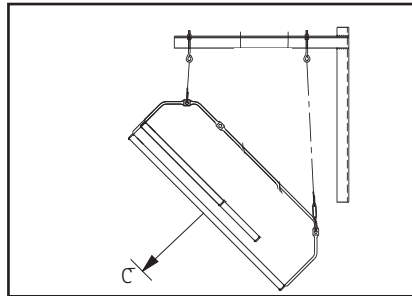

Note If heater is to be mounted at an angle (Fig 2) the burner must be on lowest leg.

Important The heater should slope downwards towards the return bend by approx 20mm for both horizontal and wall mounted installations.

Figure 3

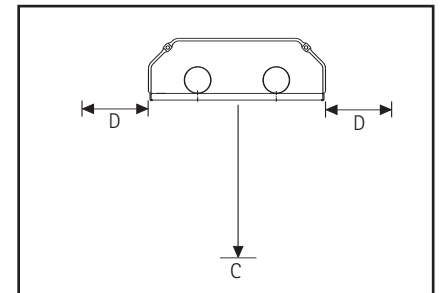

6 Heater assembly U Tube

Figure 5

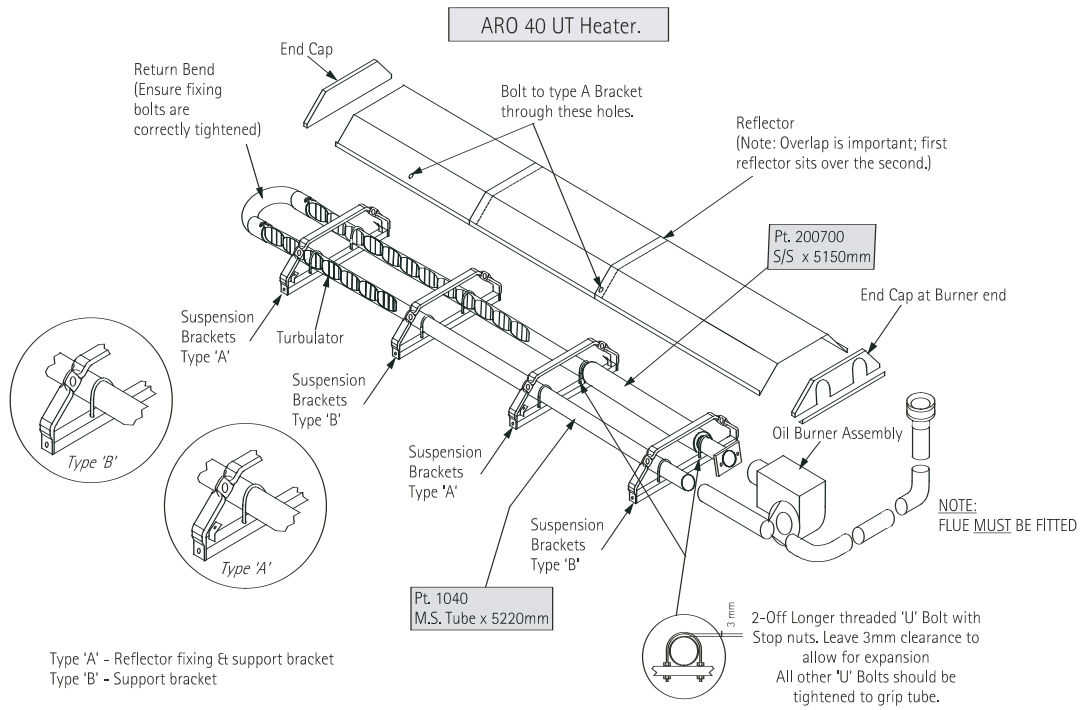

ARO 40 UT Heater
Typical arrangement.

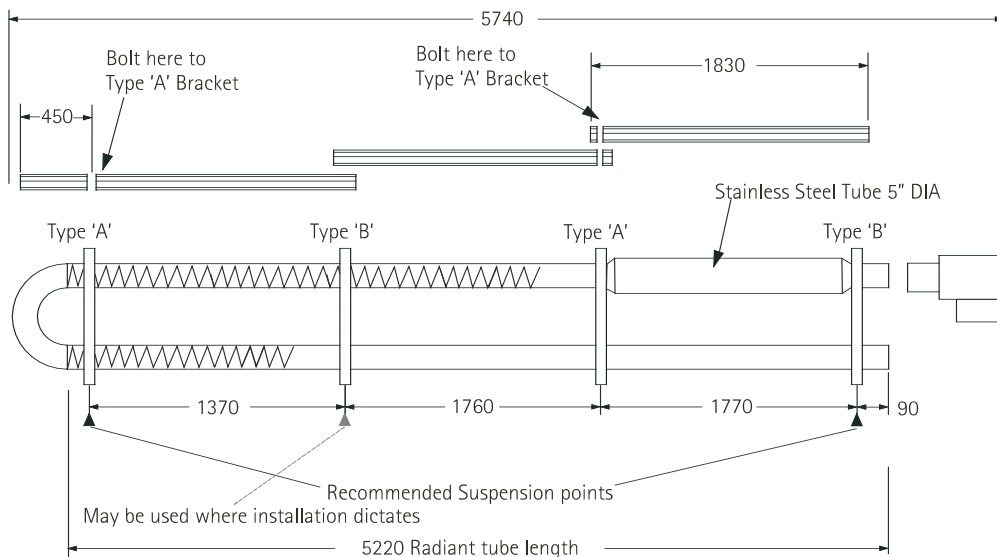

Type 'A' - Reflector fixing Et support bracket
Type 'B' - Support bracket

All dimensions in mm.

6 Heater assembly SL

Figure 6

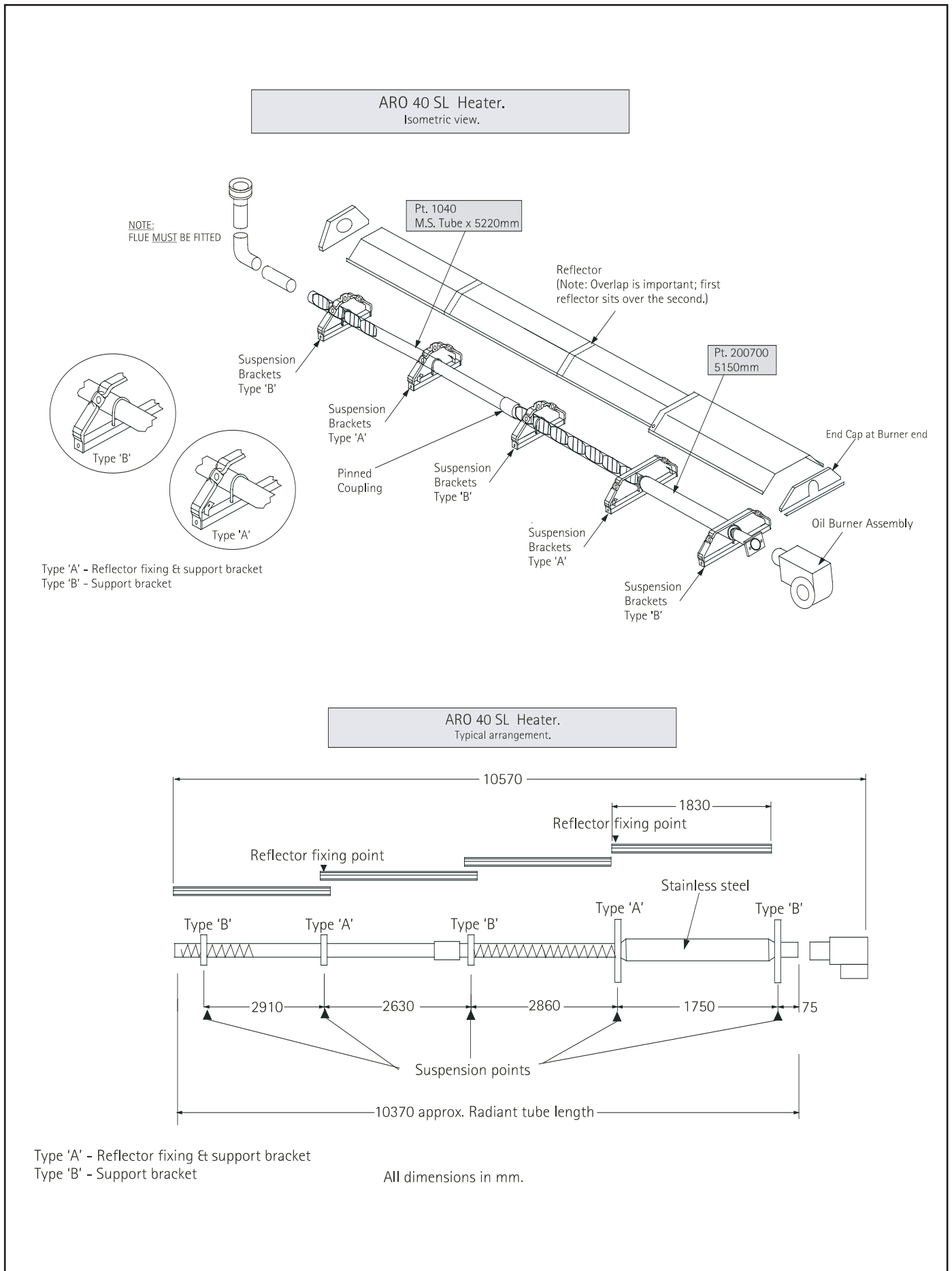

7 Flue details

Flue details

Each heater must be individually flued.

Stainless steel twin wall flue is recommended to minimise condensation. The product must be used with a flue to the outside.

Flue diameter 100mm (4").

An approved terminal must be used.



Maximum flue length is 4m (13ft).

Flue termination must be vertical.

Maximum bends : 2

8 Ventilation requirements

Permanent ventilation must be ensured.

Natural Ventilation

(Preferably at low level)

Up to and including 60kW: 4.5cm²/kW.

Over 60kW : 270cm² + 2.25cm²/kW in excess of 60kW total rated input.

Forced Ventilation

Minimum proven air flow is 2.35m³/h/kW of total rated input.

9 Ducted air for polluted/dusty atmospheres



A fresh air ducted inlet is available as an option to prevent ingress of process dust, chlorinated vapours etc. If installation is in a potentially polluted atmosphere the installer must consider prior to installation, the requirement for this option. The ducted air inlet is to be connected between the burner and a suitable 100mm ducted air feed pipe to outside.

10 Oil type and supply details

Technical data

Model		
ARO40		
Fuel type		35 sec gas oil class D visc 1.5E at 20°C
Oil supply connection		RC 1/4 BSP Male
Heat input	Gross	38kW
Heat input	Nett	35.7kW
Flow rate	Lts/Hr	3.6
	Gals/hs	0.8
Nozzle size/Spray Angle		Danfoss 0.85 30S
Burner pump pressure		
	Bar	9
	PSI	130

Note Only use nozzles of identical type as supplied by manufacturer

Pre heater

In cold climates with continued sub zero temperature, consideration must be given to heating and lagging of the oil tank.

Insulate external pipework to reduce the potential of freezing.

To prevent freezing ensure winter grade fuel is used during the winter.

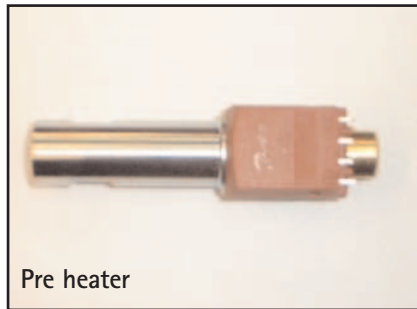

Pre heater

If temperatures are likely to fall below -4°C. A burner with pre- heater should be used to stop waxing of the oil.

The oil supply line shall be sized to ensure that the required flow rate at the burner is achieved at all times.

Oil lifter installation see Fig 7. page 7 (Single Burner). Lift pump/installation. See Fig 8. page 7. (Multiple Burner).

It is recommended that isolation valves are provided to facilitate servicing. Oil storage tanks must be installed outside the building in accordance with the regulations in force.

- A ring main pressure of min 0.5 to 1.5 bar gauge must be used.
- Use pressure regulating valves as appropriate. The flexible oil line must be used to allow for expansion of the heater.

Fire valve

A fire valve (operating temperature 70°C) must be utilised to sense each burner installed. The oil shut off valve should be sited externally of the building. (See Fig 7 and 8. Page 7 on the feed from the storage tank.

Lift Pumpset

Where a lift pump set (Part No 200140) is used it is recommended that the pump is wired into the control panel to give continuous oil circulation. This will assist in preventing waxing of the oil during the winter period and also ensure a continuous delivery of oil to the burners.

Flexible oil lines

Where the flexible oil lines connect between the fixed oil supplies and burner, do not allow lines to become stretched or stressed allow 'Easy' bends, which will compensate for expansion of the heater.

Figure 7 Single Burner Installation (with part number identification)

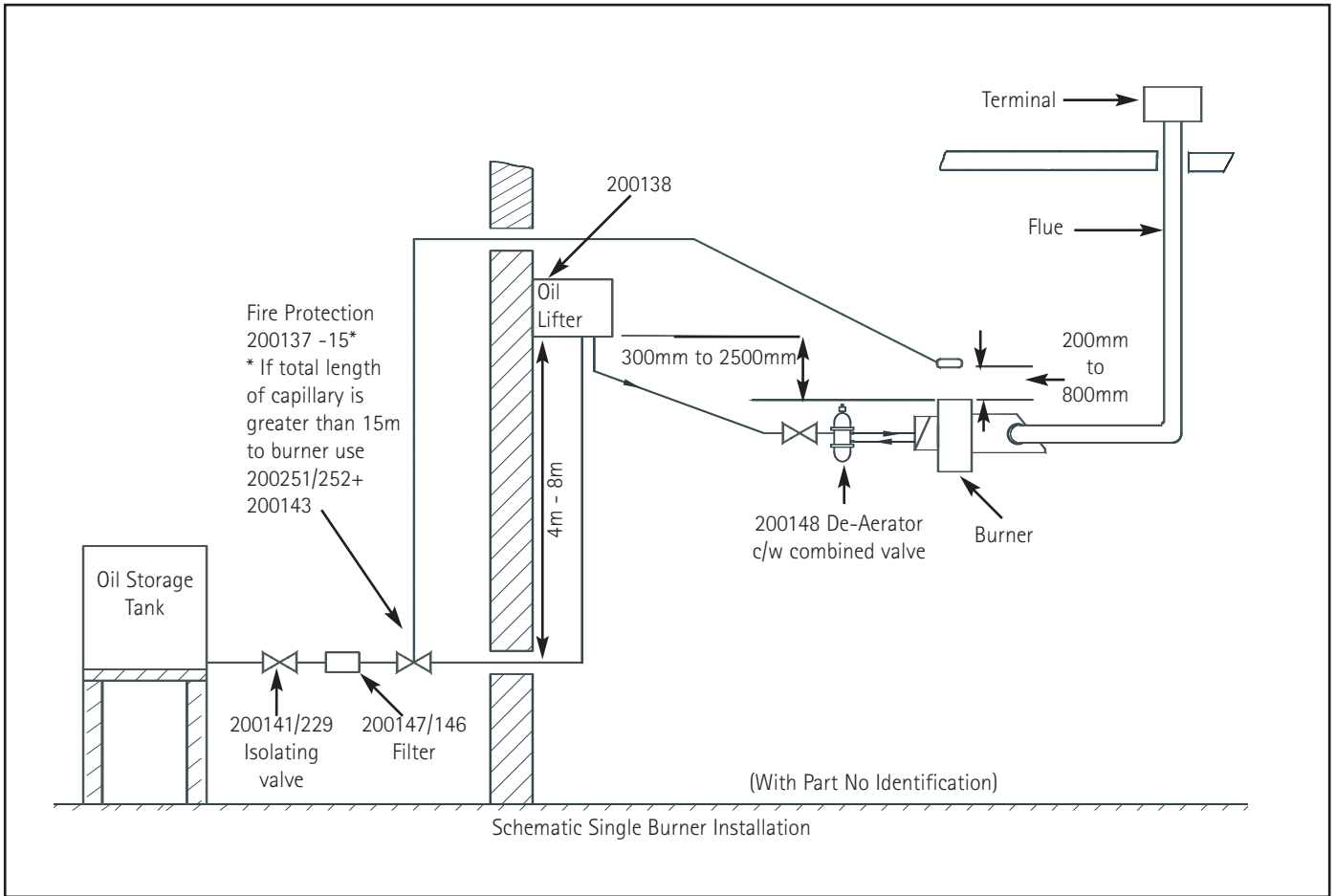
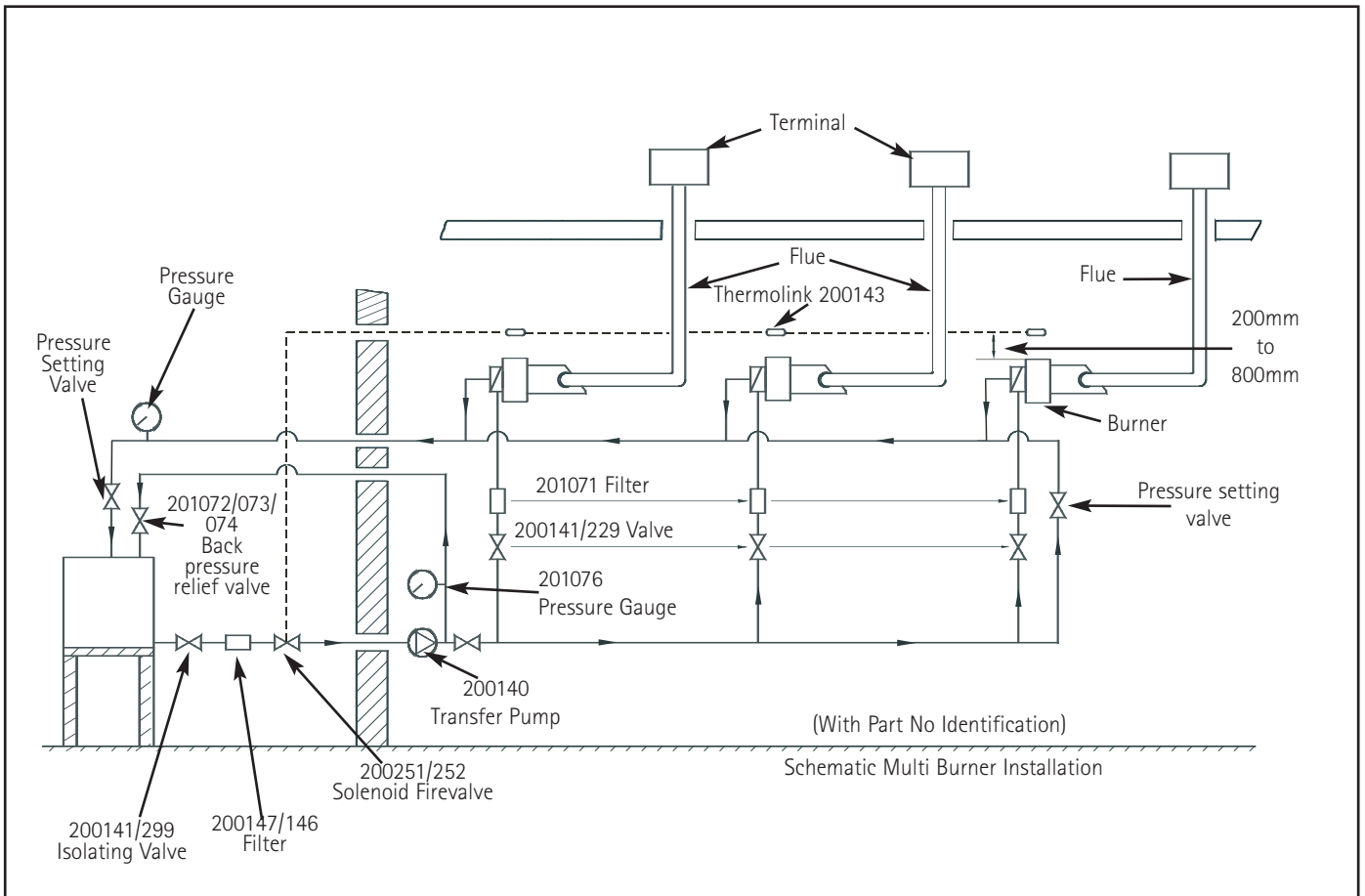
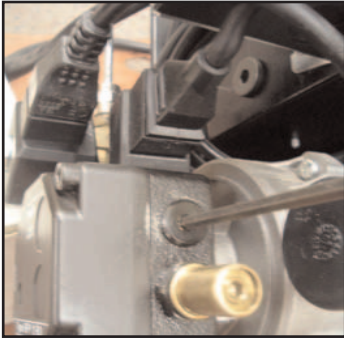

Figure 8 Multiple Burner Installation (with part number identification)



Burner start up procedure

Turn on the oil supply, connect electrical supply. Ensure that the thermostat and time clock are calling for heat. Bleed the air through the pump by slackening the oil pump plug.



Note Where a deaerator is used, release the air through knurled nut on the top of the deaerator.



During this purging sequence the burner may go to lock out.

Depress lockout reset.



Once the air is purged, retighten the oil pump plug.

Check air regulator is set to 4.5.



If adjustment is required see Figure 11.

Observe start up sequence;

- 1 Fan runs
- 2 Spark ignition is energized
- 3 Oil solenoids open
- 4 Ignition successful

If ignition fails air may still be present within the system. Purge the air as necessary. Depress lockout reset to restart ignition sequence.

Turn off electrical supply and attach the oil pressure gauge to pressure gauge port on pump firstly removing oil pump plug.

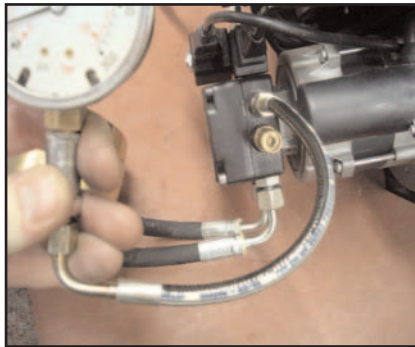

Reconnect the electrical supply. Check the oil is set to 130psi (9bar) if necessary adjust at oil pump with a suitable allen key.

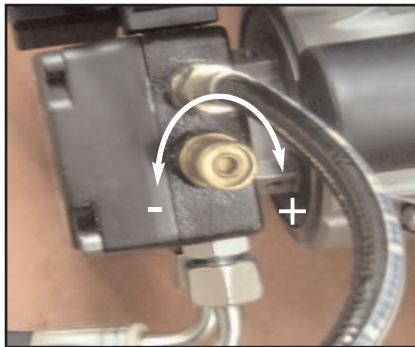

Run the burner for a minimum of 15 minutes, then check the combustion products in the flue with a suitable gas analyser adjust air regulator to give CO₂ of 10-10.5% and a smoke No. 0.

Figure 11 Air regulation

To adjust air flow, loosen the two screws 'B' and turn the air damper as required.

Re-tighten the screws 'B'.

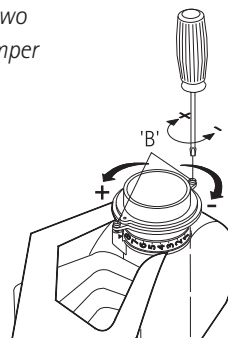

11 Routine servicing and fault finding

Radiant tube inspection.

Brush away any dust on the exterior of the emitter tubes.

To remove the burner

Disconnect electrical supply by slackening two M8 bolts, twist burner and remove. Inspect the emitter tubes internally. If there is any appreciable build up of dust or deposits the tubes should be cleaned internally.

Detach return bend and remove the turbulators. The two tubes can then be cleaned by passing rods and a suitable scraper through them or by use of an industrial vacuum cleaner with a long extension.

Check burner

Remove 3 screws securing air intake and use soft brush.



Clean impellers internally.



Open access door. Remove 2 screws.



Figure 9

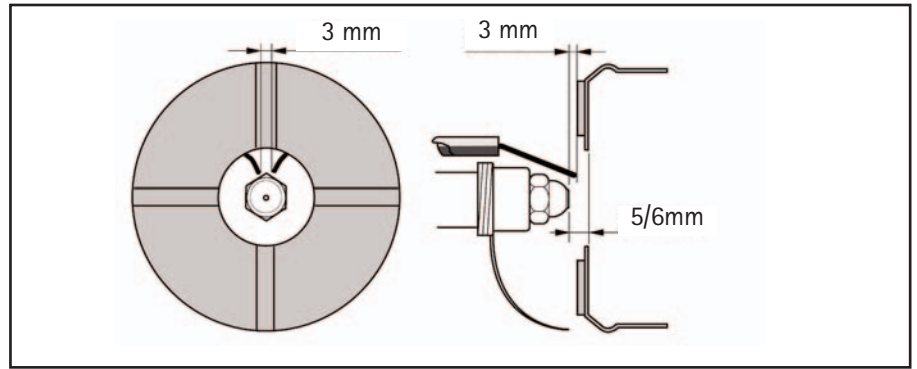

Clean impellor externally



Remove 4 screws securing pump cover.



Check and clean pump filter.



- Clean diffuser.
- Electrodes replace or clean as necessary. Ensure correct position as Figure 9.
- It is necessary to replace the nozzle at each service to gain access. Follow steps in section 12 Replacement of Parts.

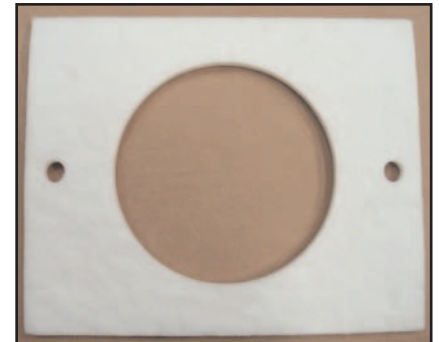

Replace burner mounting gasket at each service. (See above).

Reflector

The reflectors can be cleaned with a soft cloth and detergent in water. A mild non abrasive metal polish may be used in cases of extreme discolouration. Dirty reflectors will increase the heat radiation upwards into the roof space by 3-4%.

Flexible oil line

The flexible oil lines should be replaced annually.

Oil filters to the burner

Inspect and clean filter elements and replace elements where necessary. Recommission heater follow burner start up procedure.

Figure 11

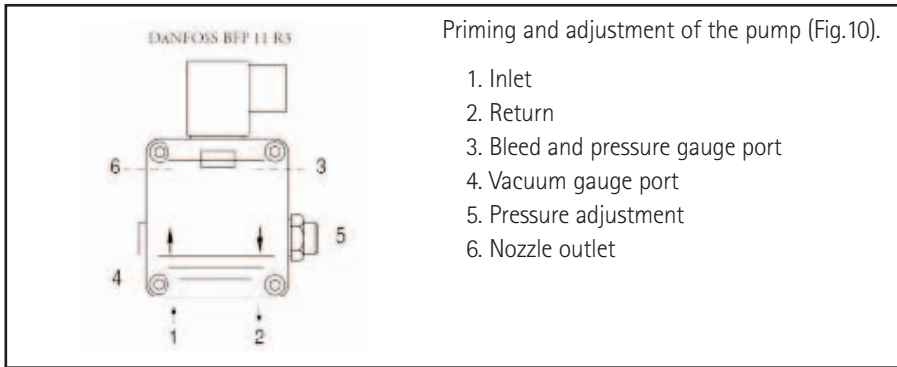

Trouble shooting checklist

Symptoms	Fault check
Burner will not start Ensure burner lockout has been reset.	Mains switch not on. Blown fuse. Timer/thermostats not made. Fault in control box or fan motor.
Burner pre-purges and stops	Fault in control box Photo cell. Seeing the light or faulty.
Burner does not spark during cycle and stops	Transformer. Fault in control box.
Burner does not ignite	Dirty ignition electrodes or incorrect setting. Fault ignition transformer. Blocked nozzle. oil solenoid failure. Oil pressure too low/Check oil supply. Blocked oil filter. Excessive combustion air for nozzle capacity/check air setting Fault in control box.
Burner ignites and then stops	Faulty nozzle. Photo-resistor does not 'see' flame. Excessive combustion air for nozzle capacity. Fault in control box. Oil pressure too low. Blocked oil filter.

12 Replacement of parts

Disconnect electric and oil supplies to the burner. Remove the burner by slackening two M8 bolts - twist and remove the burner.

Removal of blast tube.

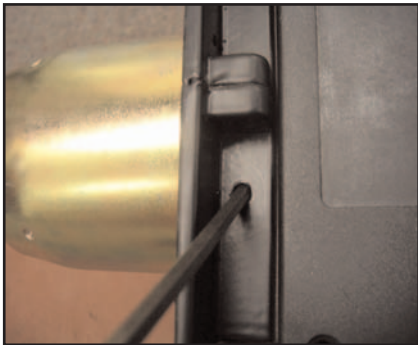

Slackening grub screw

Remove blast tube by twisting and pulling outwards.



Note When refitting blast tube do not overtighten grub screw.

Removal of ignition electrodes.

Remove securing screw.



Note When replacing electrodes - Ensure setting positions are correct. See Fig 9.

Removal of diffuser

Slacken grub screw and remove diffuser.



Note When refitting, ensure the diffuser sits against top of the screw head.

Removal of nozzle

Using a suitable spanner grip nozzle and remove, use a second spanner to stop the nozzle assembly rotating.

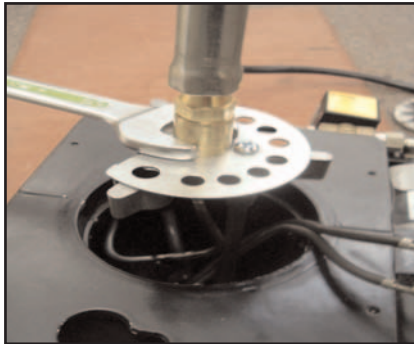

When replacing nozzle, do not touch front face of the nozzle.

Do not overtighten the nozzle when replacing, as this may damage the sealing face.

To Replace the Pump

Remove oil lines. Disconnect solenoid coil. Disconnect oil feed line to burner.

Slacken 3 grub screws and remove pump.



When refitting, ensure pump coupling locates correctly into the motor.

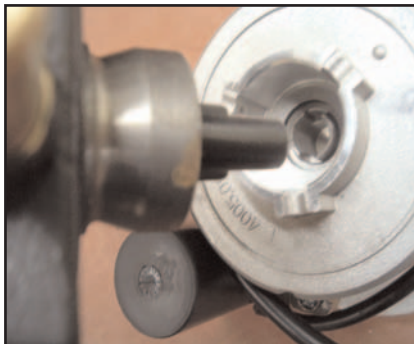

To Replace the Motor

Disconnect oil pump by slackening 3x grub screws. Remove 2 screws open access door.



Release the fan impellor by slackening grub screw through access door.

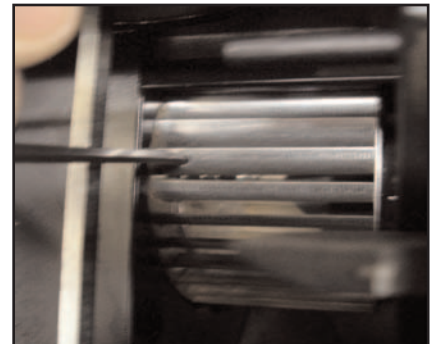

Remove 3 screws securing motor to burner body. Disconnect electrical connection to control box.



To Replace Transformer

Remove screws securing access door and lift. Remove screws securing transformer. Disconnect electrode leads. Disconnect wiring from control box.



To Replace the Photo Resistor

Pull out of location. Depress clip and pull photo resistor from the socket.



Note When replacing ensure photo resistor cell faces forward towards blast tube.

13 Parts : Spares and installation

	Description	Part Number		Description	Part Number
	Oil Pump	200154		Nipple/washer	200156
	Motor	200153		Primary solenoid	200164
	Nozzle	200152		Oil hose	200155
	Secondary solenoid	200149		Pump coupling	200161
	Blast tube	200151		Gasket	200008
	Electrodes	200158		Oil line filter	201071
	Diffuser	200168		Pump filter	201095
	Electrode leads	200162		De-aerator	200148
	Control box	200160		De-aerator filter	201075
	Photo resistor	200150		Pre-heat kit	200603
	Transformer	200157		Turbulator Burner Leg	200015T
				Turbulator Flue Leg	6602



Ambi-Rad Limited Fens Pool Avenue
Brierley Hill West Midlands
DY5 1QA United Kingdom

Telephone 01384 489700
Facsimile 01384 489707
UK sales email sales@ambirad.co.uk
Website www.ambirad.co.uk

AMBIRAD is the registered
trademark of Ambi-Rad Limited.

Due to continuous product
innovation, Ambi-Rad reserves
the right to change product
specification without due notice.

AMBIRAD
ENERGY EFFICIENT HEATING SYSTEMS

Document reference number GB/ARO/104/1104