

# USERS INSTALLATION AND SERVICING INSTRUCTIONS.

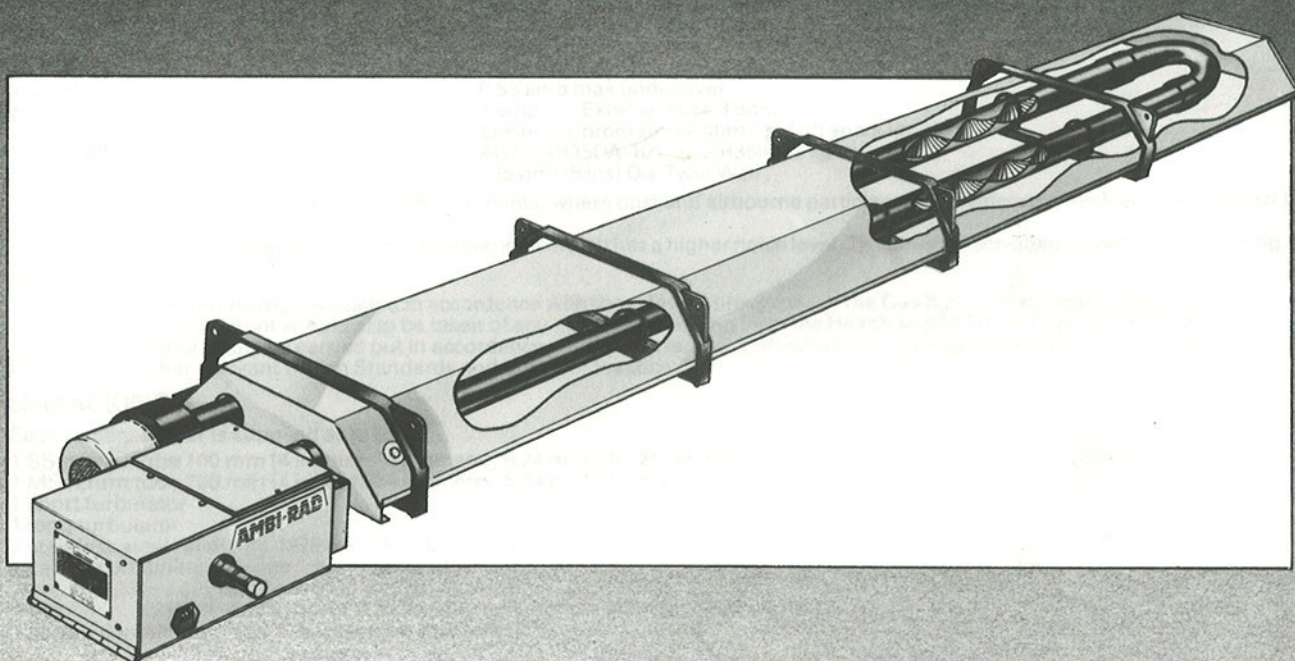

## MODEL AR35/AR35I

AR35 (G.C. No. 36 229 10)

AR35I (G.C. No. 36 229 16)

IMPORTANT

This appliance is for use on Natural Gas or Propane as indicated on the Data Badge. It must be installed and serviced by a competent person as stated in the Gas Safety (Installation & Use) Regulations 1984.

**AMBI-RAD**  
radiant heating systems

# INSTALLATION INSTRUCTIONS FOR AMBI-RAD MODEL AR35/AR35I

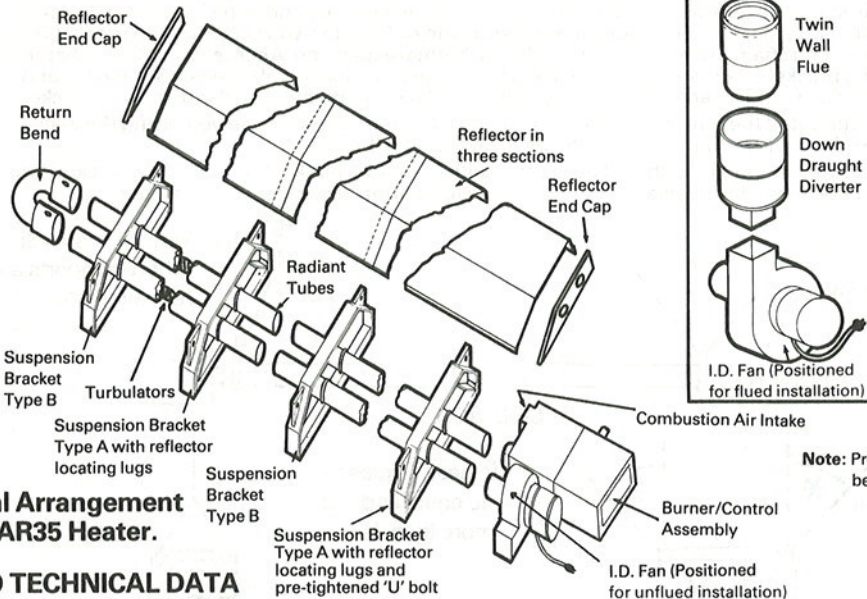

**Fig. 1. General Arrangement of AMBI-RAD AR35 Heater.**

## 1 AMBI-RAD TECHNICAL DATA

Model	AR35/AR35I
Heat Input	Max: 35 kW (119,400 Btu/h) Min: 28 kW (95,500 Btu/h)
Nominal Gas Rate (Natural Gas)	Max: 3.28 m <sup>3</sup> /h (116 ft <sup>3</sup> /h) Min: 2.62 m <sup>3</sup> /h (93 ft <sup>3</sup> /h)
Gas Supply Connection	R <sup>1</sup> / <sub>2</sub> (1/2" B.S.P. external)
Electrical Supply	240 v 1 phase 50 Hz
Current Rating	0.55 amp max (inductive)
Internal Fuse Rating	1 amp External Fuse 3 amp
Ignition	Electronic programme start up with spark ignition
Total Installed Weight	AR35/AR35DA-101 kg; AR35I-112 kg
Exhaust Flue (Optional)	125 mm (5 ins) Dia Twin Wall

The AR35 should only be used in clean environments, where dust and airborne particles are in evidence a fresh air inlet lid must be fitted as per section 8.

An open port burner is available for dirty environments which has a higher noise level. This must be specified at the time of ordering.

### Standards

The Ambi-Rad heater must be installed in accordance with the relevant provisions of the Gas Safety (Installations and Use) Regulations 1984. Due account should also be taken of any obligations arising from the Health and Safety at Work etc. Act 1984. In addition the installation must be carried out in accordance with the current I.E.E. Regulations, the requirements of BS 5440: Part 1, BS 6896 and any other relevant British Standards and Codes of Practice.

## 2 UNPACKING

Each radiant heater is supplied as follows:

- 1 SS burner tube 100 mm (4 in) outside diameter, 5.24 m (17 ft - 2 1/4 in) long
- 1 MS return tube 100 mm (4 in) outside diameter, 5.24 m (17 ft - 2 1/4 in) long
- 1 short turbulator
- 1 long turbulator
- 3 stainless steel reflectors 1829 mm (6 ft - 0 in) long
- 1 carton containing: burner/control assembly  
induced draught fan  
return bend, 2 Reflector end caps and sundry components.
- 1 carton containing: Heater suspension brackets

## 3 ASSEMBLY

Support radiant tubes on blocks, trestles etc. at least 150 mm (6 in) above floor level, preferably under the position of installation. Ensure tubes are clean internally and position tube weld away from reflector. Space the tubes 300 mm (12 in) apart.

The SS burner tube (marked with labels) to be positioned on the right hand side of the MS return tube when viewed from the burner end.

Slip the 4 suspension brackets onto the tubes and attach by means of 'U' bolts and nuts. Note there are 2 types of suspension brackets. Type A and B (Fig. 3). Type A has additional reflector locating lugs and one has a pre-tightened 'U' bolt. Position these brackets as shown in Fig 2. Tighten the 'U' bolts and nuts to secure the tubes within these brackets.

Before fitting the return bend locate the turbulator into each radiant tube flush with the end of the tube. Short turbulator in burner tube. Slip the return bend onto the tubes with the two pinch screws facing upwards. Ensure that each tube enters the bend fully.

Correct positioning of suspension brackets is IMPORTANT for satisfactory installation and operation of the heater. Incorrect positioning of the suspension bracket will give either too much or too little reflector overlap which is essential for linear thermal expansion of the heater. Note the first type A bracket must not exceed 150 mm from burner face.

**Note:** Different size suspension brackets are fitted on the AR35I model. I denotes insulated reflector model

Tighten 'U' bolts properly or twisting forces will be imposed on the 'U' bolts causing damage to the heater.

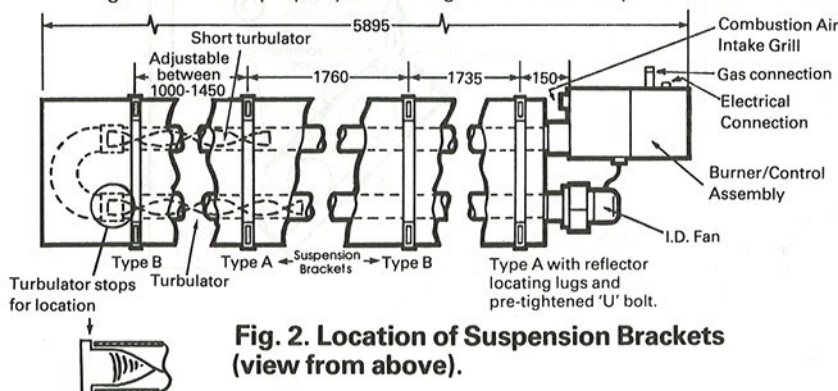

**Fig. 2. Location of Suspension Brackets (view from above).**

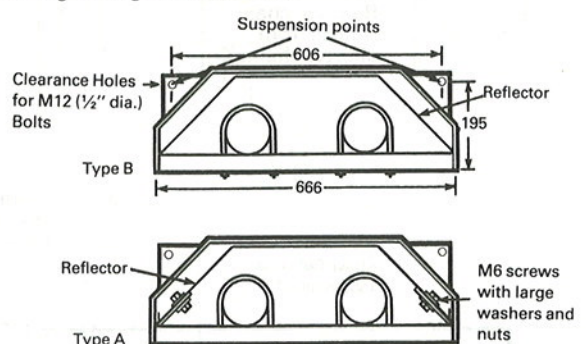

**Fig. 3. Section Through Suspension Brackets.**

## 4 INSTALLATION

We recommend that at this stage the tube assembly is raised into position and suspended by its two end brackets only from previously fixed chains of 4 mm gauge galvanised welded link construction or fixed to two wall mounting brackets which must incorporate a short section of hanging chain to allow movement due to thermal expansion. Alternatively 10 mm diameter mild steel drop rods can be used. Wall mounting brackets must support the heater at an angle of inclination of between 35° and 55° and are available from the manufacturer (AR35 and AR35I only). The angle is varied by adjusting the drop rod bolts or chain on each bracket.

**Note:** If the heater is to be wall mounted the return bend must be on the left-hand side when viewed facing the wall. A 90° bend must be fitted to the fan to discharge products of combustion horizontally away from the heater.

Attachment to the heater bracket support lugs should be made by either a spring hook, 'D' shackle, nut, bolt and large washers, or in the case of drop rods, a formed hook and due allowance must be made for thermal expansion of the heater.

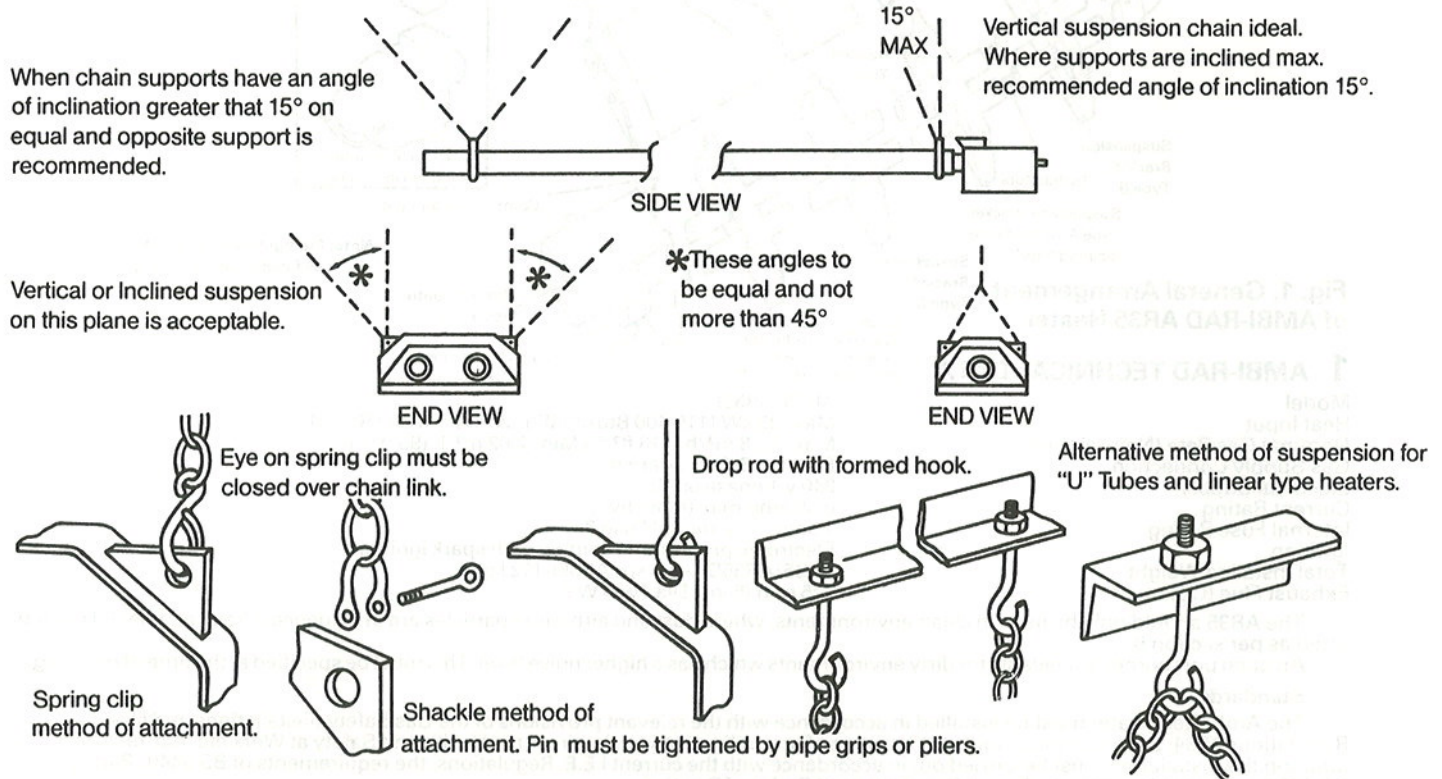

The hanging attachments to overhead steelwork etc. must be purpose made to good sound engineering practice or of a proprietary type fixing.

They must be adequately fixed and designed to carry the whole weight of the heater and to permit free movement due to linear expansion.

In the event of suitable roof steelwork not being available, additional steelwork should be fitted to enable vertical hangers to be used for suspending the heaters.

If there is any doubt as to the strength or suitability of roof steelwork to which heaters are to be suspended, please refer to consultant/architect/Client owner of the building.

The recommended minimum and preferred mounting heights for the AMBI-RAD heaters are as follows:

MODEL	MOUNTING POSITION	RECOMMENDED MINIMUM MOUNTING HEIGHT	PREFERRED MOUNTING HEIGHT
AR35	Horizontal	4.3 m (14 ft)	6.1m - 9.1m (20ft - 30ft)
	Inclined/Wall Mounted	3.6 m (12 ft)	4.6m - 5.5m (15ft - 18ft)
AR35I	Horizontal	4.3 m (14 ft)	6.1m - 9.1m (20ft - 30ft)
	Inclined/Wall Mounted	4.3 m (14 ft)	4.6m - 5.5m (15ft - 18ft)

The proposed position of the heater should be selected so that the above clearance distances to combustible materials will be ensured.

**Fig. 4. Minimum Clearance Distances.**

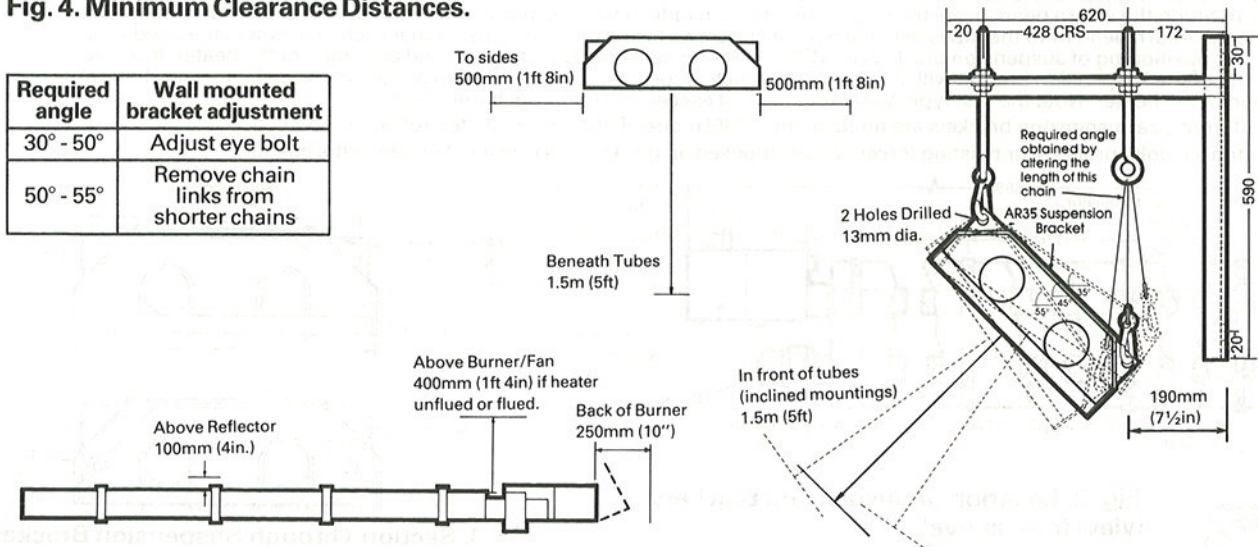

Remove the protective plastic film from the reflector surface.

**Note:** When removing protective covering from reflector do not stand on inside face of reflector.

Each section of the reflector has two holes punched at one end. This end is firmly fixed by bolting to the lugs provided on suspension bracket type A. The other end of each reflector section is free floating in suspension bracket type B thereby allowing for thermal expansion.

Position the first reflector section and secure it with the M6 bolts, nuts and large washers provided to the suspension bracket nearest the burner.

Position the second and third sections of reflector so that they overlap with the punched holes in line with the lugs provided on the third suspension bracket from the burner. Secure using M6 bolts, nuts and large washers passing through both reflector sections.

Before attaching burner & fan assembly, fit reflector end caps and secure to reflectors with screws provided.

Slide burner/control assembly onto the right hand tube (when viewed facing the open ends of the tubes) ensuring it is fully engaged and horizontal and secure with pinch screws provided.

Slide fan assembly onto left hand tube ensuring it is fully engaged and with fan discharge outlet facing vertically upwards if the heater is to be flued or horizontally away from the burner if unflued and secure with pinch screw provided.

Insert three pin fan connection plug in socket on burner housing.

## 5 GAS CONNECTION

The gas connection on the AMBI-RAD heater is R $\frac{1}{2}$  (1/2" B.S.P. external thread).

GAS	NATURAL GAS	PROPANE
Maximum supply pressure	30 mbar (12 in. wg)	50 mbar (20 in. wg)
Minimum supply pressure	16.5 mbar (6 in. wg)	30 mbar (12 in. wg)
Burner setting pressure	Max: 11.2 mbar (4.5 in. wg) Min: 7.2 mbar (2.9 in. wg)	22.5 mbar (9 in. wg)

A gas meter is connected to the service pipe by the local Gas Region or local Gas Region contractor. An existing meter should be checked preferably by the Region to ensure that the meter is adequate to deal with the rate of gas supply required. Installation pipes should be fitted in accordance with BS 6891: 1988 such that the minimum pressure at least as stated above will be achieved. Pipes of a smaller size than the heater inlet gas connection should not be used. The complete installation must be tested for soundness as described in the above Code.

The gas supply must not be in a position where it is subject to overheating.

A gas union service cock **MUST** be fitted in the gas supply close to the heater, but not onto the burner itself.

It is essential to provide some flexibility in the final gas connection by use of a tested and certified metallic hose to BS 6501: Part 1, 1984 (minimum acceptable quality Type B Class 1) or copper expansion loop. When stainless steel flexible hoses are used the hose should be connected in a 180° bend without any strain or torsion. See leaflet 410/12/88 for details.

**Note:** Take care when making a gas connection to the heater not to apply excessive turning force to the internal controls.

## 6 ELECTRICAL CONNECTION

**WARNING:** THIS APPLIANCE MUST BE EARTHED.

Supply 240 v 50 Hz Single Phase.

Current Rating 0.55 amp max (inductive).

Fuse: Internal 1 amp. External 3 amp.

All electrical work should be carried out to I.E.E. standards by a competent electrician.

The electrical connection to the heater is made by means of a three pin plug-in power connector. Live, Neutral and Earth connections should be made via a flexible supply cable to the power connector and routed clear of the heater or tubes. The flexible supply cable should be of 0.5 mm<sup>2</sup> complying with BS 6500, 1975.

### IMPORTANT

The wires in the mains lead are coloured in accordance with the following code:

Green and Yellow	- Earth
Blue	- Neutral
Brown	- Live

Instructions for connecting mains lead to plug:

Connect Green and Yellow to plug terminal marked E or Green or Green and Yellow.

Connect Blue wire to terminal marked N or Black or Blue.

Connect Brown wire to terminal marked L or Red or Brown.

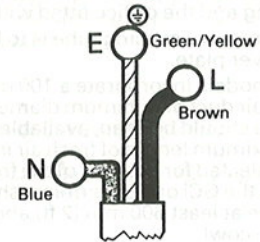

It is recommended that the electrical circuit controlling the heater or group of heaters incorporates thermostats, a time switch and if required manual control switches and a frost thermostat see Fig 5

**Important:** All such controls and switchgear must be rated to handle the total inductive load of the circuit they control. The inductive load per AMBI-RAD Model AR35 and AR35L is given above. For large installations the use of relays or contactors should be considered.

The method of connection to the electricity supply must facilitate complete isolation and should be made via a fused double pole isolation having a contact separation of at least 3 mm in all poles and supplying the appliance only.

Alternatively connection may be made via a fused three pin plug and unswitched shuttered socket both complying with the requirements of BS 1363.

Ensure that a copy of the lighting instructions - (back page of user manual) is affixed adjacent to the electricity supply switch. Should this switch serve more than one heater it is only necessary to fit one plate per service switch.

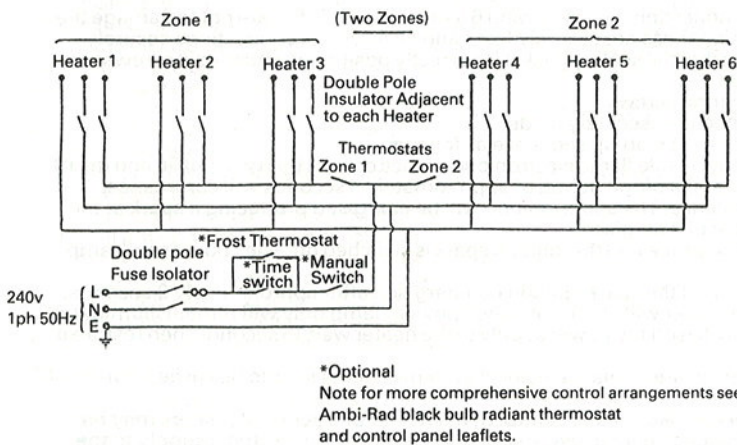

\*Optional  
Note for more comprehensive control arrangements see Ambi-Rad black bulb radiant thermostat and control panel leaflets.

Fig. 5. Typical External Wiring Diagram.

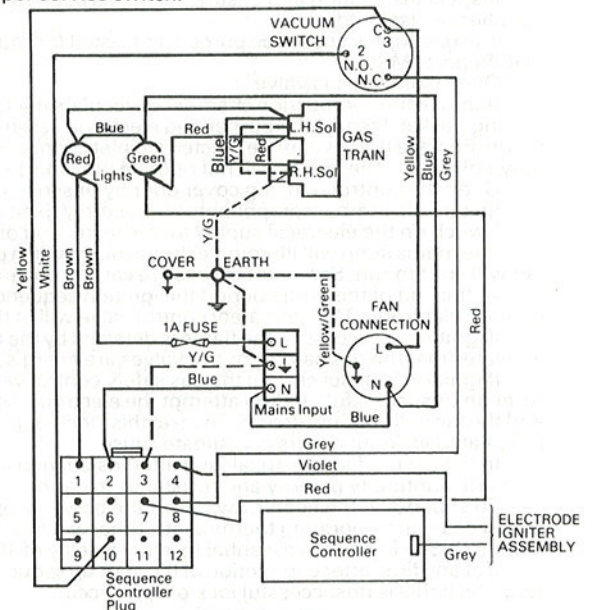

Fig. 6 Internal Wiring Diagram.

## 7 FLUE CONNECTION

### 7.1 Unflued Installation

The Ambi-Rad heater may be installed without flue to atmosphere providing the air supply and building ventilation requirements as stated in BS 6896: 1987 are complied with and providing due consideration is given to the possibilities of condensation forming on cold surfaces.

Permanent ventilation required is as follows:

Natural Ventilation (to be fitted at high and low level)

Low Level - When air change rate is less than 37.5 m <sup>3</sup> /hr/kW of total rated input.	either	1.4 cm <sup>2</sup> for each 1 m <sup>3</sup> /h per kW below 37.5 m <sup>3</sup> /h per kW.
	or	52 cm <sup>2</sup> /kW of total rated input.
High Level - Above areas where personnel are working.	—	As above.
<u>Mechanical Ventilation</u>		
Minimum proven air flow	—	37.5 m <sup>3</sup> /h/kW of total rated heated input.

For detailed information please refer to AMBI-RAD design manual.

If the heater is installed without a flue, ensure that combustion gases do not impinge on combustible materials. The maximum permitted temperature for such materials is 65°C (BS 3561).

### 7.2 Flued Installation

The AMBI-RAD heater may be installed with a flue. A down-draught diverter (supplied as an optional extra by the manufacturer) must be fitted to the induced draught fan exit by means of the screws and clamp plates provided.

The diverter is designed to accept a 125 mm (5 in) nominal bore proprietary twin wall metal flue pipe complying with BS 715. The joint should be sealed with heat resistant caulking and faced off with fire cement. If single wall metal flue pipe complying with BS 715 is used then an adaptor will be required.

A flue pipe should be adequately supported at regular intervals from the building structure and terminated externally with a British Gas Tested and Certified terminal. The maximum flue length is 9 m (30 ft) and maximum number of bends is two. All connections in the flue pipe must be properly sealed. Permanent ventilation is required as follows:-

Natural Ventilation (preferably at low level)

Upto and including 60 kW	—	4.5 cm <sup>2</sup> /kW
Over 60 kW	—	270 cm <sup>2</sup> + 2.25 cm <sup>2</sup> /kW in excess of 60 kW total rated input.

Forced Ventilation

Minimum proven air flow	—	2.35 m <sup>3</sup> /h/kW of total rated input.
-------------------------	---	---

For detailed information please refer to AMBI-RAD design manual.

## 8 FRESH AIR DUCTED INLET (Models AR35 DA and AR35 I/DA)

When the AMBI-RAD heater is to be installed in locations where there is airbourne dust or where there is a polluted atmosphere, a ducted fresh air supply must be provided to the burner. In addition an open port burner can be used where dust conditions are moderate.

Where a fresh air ducted inlet is to be fitted to the burner assembly the Stainless Steel Air intake grill must be removed from the burner casing and the orifice fitted with a blanking off plate.

**Note:** The pressure sensing tube is to be re-positioned to align with the orifice in the ducted fresh air connection of the combustion chamber cover plate.

These models incorporate a 100 mm (4 in) fresh air duct connection.

A fresh air duct of minimum diameter 100 mm (4 in) should be connected to the combustion chamber cover plate inlet duct. A flexible joining piece should be used, available from the manufacturer, fixed with hose clips to facilitate disconnection when servicing the burner.

The maximum length of fresh air inlet duct is 7 m (23 ft) of 100 mm (4 in) diameter duct. Maximum number of bends is two. A position should be selected for the inlet of the fresh air duct such that will receive dust free clean air. A cowl of the British Gas Tested and Certified type such as the GCI or GLC terminal should be fitted at the inlet of the duct. If the duct inlet is located on a roof the underside of the inlet cowl must be at least 600 mm (2 ft) above roof level and at least 250 mm (10 in) higher than any projection on the roof within a 2 metre radius of the cowl.

## 9 INSULATED REFLECTOR MODEL AR35I

An insulated reflector can be used to conserve upward radiation from the reflector. In addition, insulation should be used where dust is likely to settle on the reflector to reduce the increased radiation caused by the dirty reflector.

After the reflectors are assembled, the insulation should be attached to the back of the reflector with the spring ties provided. The insulation fits underneath the suspension brackets.

## 10 COMMISSIONING

Inspect installation and ensure that it has been carried out in accordance with these instructions. Ensure that electrical and gas supplies are isolated.

The gas supply should be purged and tested for soundness in accordance with the British Standard Code of Practice CP 331, Part 3 and BGC Report 1M/2.

Open isolating gas valve.

Remove the combustion chamber cover plate ducted air inlet connection by unscrewing 6 fixing screws. Take care not to damage the sealing gasket. Inspect the burner and electrode assemblies ensuring these are securely fixed and all electrical connections securely made. Replace the cover plate, ducted air inlet connection, ensuring that the sealing gasket is correctly positioned and the six screws are fully tightened. The heater will not operate until this plate is refitted.

Open the control housing cover door by unscrewing the 2 securing screws.

Ensure all internal components are securely fixed and all connections securely made.

Switch on the electrical supply to the heater and observe the correct start up sequence as follows.

The mains lamp will illuminate the vacuum switch checking relay (inside flame electronic sequence control box) will pull in and the ID fan will start to run. Safe-start checks are carried out automatically and a purge period of approximately 9 seconds will commence.

At the end of the purge period the ignition sequence will commence. The spark ignition will be energised producing a spark at the ignition electrode. The gas safety control valve will at the same time be energised.

If ignition is successful the flame is detected by the flame sensing probe and the ignition spark is switched off. The "burner on" lamp indicates that the gas safety control valves are energised.

If ignition is unsuccessful the gas safety control valve is closed and the spark ignition de-energised after approximately 2 seconds.

After an unsuccessful ignition attempt the electronic sequence controller will "lock-out", the "power" lamp only will remain illuminated and the fan will continue to run. To reset this "lock-out" condition switch off the power supply to the heater wait 15 seconds then restore it. If repeated lock-out occurs investigate cause.

In the event of an electrical fault after installation of the appliance, preliminary electrical systems checks should be carried out (re-earth continuity polarity and resistance to earth).

To shut down the heater, switch off the power supply to the heater. Automatic control of the heater or a series of heaters may be achieved by incorporating thermostats, timeswitches, frost thermostats, manual over-ride switches etc. in the electrical supply to the heater(s). See Fig. 5. It is essential to allow a delay of 15 seconds after switching off a heater before attempting to restart.

If at any time after completion of the start up sequences, loss of flame should occur the electronic sequence controller will attempt to reignite. If this is unsuccessful lock-out will occur.

Set burner gas pressure as follows. Unplug mains input connector to heater. Unscrew the 2 fixing screws in the hinged safety control housing lid and swing away. Remove pressure test point screw and connect a 'U' tube manometer to the pressure test nipple located on the body of the gas valves. Remove the slotted cover from the pressure test regulator revealing the adjustable screw. Replace mains input connector and start the heater. Using a suitable screwdriver adjust the pressure regulator, turning the screw clockwise to increase the pressure or anti-clockwise to decrease the pressure. Set the burner pressure to the required figure given in Section 5. Switch off the heater by pulling out the mains input connector. Disconnect 'U' Tube manometer and refit screw in pressure test nipple. Replace cover on pressure regulator. The data badge **must** be marked by the commissioning engineer to indicate the gas pressure setting to which the burner has been adjusted to and noted heat input of heater.

If heater is flued check that there is adequate updraught at the draught diverter e.g. by means of a smoking taper.

Check the operation of the flame safeguard equipment as follows. With the heater running normally switch off the gas supply at the appliance isolating valve. Observe that the "burner on" lamp extinguishes within one second. After a purge period of approximately 9 seconds the heater should attempt to relight and if the gas isolating valves have been left off lock-out should occur indicated by power light only being illuminated and fan running.

Check the operation of the vacuum proving switch as follows with the heater running normally pull out the three pin fan connection plug thus causing the fan to slow down and stop. Within 3 seconds the burner should shut off. Observe for at least 20 seconds that there is no attempt to reignite. Then replace the three pin plug and observe that the heater proceeds to ignite in the normal way.

Close the Safety Control housing lid which is secured with the 2 fixing screws.

Hand the Users Instructions to the user and explain how to operate the heater.

Leave the Installation and Servicing Instructions at the users meter or preferably with the service/maintenance engineer/manager for use on future service calls.

**Note:** It will be noted that the emitter tube has a tendency to bow when hot, this is normal and quite acceptable.

## 11 SERVICING INSTRUCTIONS

Under normal working conditions, it is recommended that the AMBI - RAD heater has a routine service once per year. In exceptionally dirty or dusty conditions such as may occur in a foundry more frequent servicing may be desirable. Servicing work should be carried out by a qualified gas servicing engineer.

### IMPORTANT

- 1 Never rest anything, especially ladders against the heater.
- 2 Isolate gas and electrical supplies before commencing any servicing work or component exchange.
- 3 Unless otherwise instructed, reassemble parts in reverse order to the instructions given below.
- 4 Always test for gas soundness with a suitable leak detection fluid after completing any service or exchange of gas carrying components.

## 12 ROUTINE SERVICE

### 12.1 ID Fan

Remove ID fan by unplugging its electrical connection from the burner/control assembly and slackening the fan securing pinch screw. If a flue fitted this must also be disconnected. The fan will now slip off the emitter tube.

Inspect the main fan impeller and remove any dust by brushing with a soft brush. Similarly remove any dust from the finger guard covering the secondary ( cooling ) impeller and the mesh aperture in the motor cover. Ensure that the impeller turns freely and that there is not excessive play in the bearings. Do not replace fan until emitter tube inspection has been completed.

### 12.2 Emitter Tubes Inspection

Brush away any dust on the exterior of the emitter tubes.

Inspect the emitter tubes internally. If there is any appreciable build up of dust or deposits the tubes should be cleaned internally.

Remove the burner/control assembly as directed in 12.4 below.

Detach return bend by releasing the 2 pinch screws and remove the turbulators. The two tubes can then be cleaned by passing rods and a suitable scraper through them or be cleaned by use of an industrial vacuum cleaner with long extension tube.

### 12.3 Reflector

Although not considered part of an annual routine service, the condition of the reflector should be noted and the users attention drawn to any cleaning necessary. The reflectors can be simply withdrawn for cleaning by removing the four M6 nuts and bolts securing them and sliding them out of the suspension brackets once the reflector end caps have been removed. A mild non abrasive metal polish may be used in cases of extreme. The reflectors can be cleaned with a soft cloth and detergent in water.

Dirty reflectors will increase the heat radiation upwards into the roof space by 3-4%.

### 12.4 Removal of Burner/Control Assembly

Remove the burner/control assembly by disconnecting the gas and electrical supply, fresh air inlet ( if fitted ) and the fan electrical connection. Slacken the burner fixing pinch screws and draw the assembly off the emitter tube.

### 12.5 Burner/Electrode Assembly

Inspect the burner electrode assembly by removing the six dome head screws securing the combustion chamber cover plate on top of the combustion chamber, taking care not to damage the sealing gasket. Remove the burner head by unscrewing it from the injector, tacking care not to drop it onto the leads of the ignition electrodes. Matrix burner heads should be examined every 6 months for signs of blockage and cleaned by blowing compressed air in reverse direction to flow. Renew the electrode assembly if it is not in good condition. The assembly is removed by removing two 2BA screws which attach it to the sidewall of the combustion chamber. The assembly is then lifted out of the combustion chamber and the two connection cables disconnected.

If the electrode assembly is in good order check the spark electrode gap. This should be 3.5 mm  $\pm$  0.5 mm. Adjust the gap if necessary by bending the earth rod. Refit the electrode assembly in the reverse order of removal, ensuring that the electrical connections to the assembly are the correct way round and secure.

Inspect the injector and clean as necessary do not broach out. To remove or replace the injector with the burner head removed. Unscrew the injector from its carrier using a spanner on the hexagon portion of its body. When replacing the injector ensure that it is fully tightened in its carrier.

Replace the burner head. Replace the combustion chamber plate cover, renewing the rubber sealing gasket Part No. 338 if this is not in good condition.

Inspect the burner fresh air inlet duct and flue if fitted and ensure that they are free of any blockage or obstruction. Inspect the air inlet terminal and ensure this is not liable to obstruction.

Replace the burner/control and fan assemblies engaging them fully on their tubes and secure by tightening the pinch screws ensuring that both items are squarely and neatly positioned. The burner should be positioned horizontally and the fan discharge should face vertically upwards for flued heaters or horizontally away from the burner for unflued heaters as detailed in Fig. 1 of these instructions.

Re-commission the heater by following the procedure for commissioning as per section 10, taking care to check that the burner gas pressure is correctly set to that indicated on the data badge and that the vacuum switch and flame safeguard equipment function correctly.

### 12.6 Auxiliary Controls

Check that auxiliary controls such as room thermostats, switches, frost thermostats, etc. function correctly and set to operate at the desired temperatures. Ensure that the user is aware of the functions of the auxiliary control and their correct settings. For the most efficient operation of the heating system the time switch if fitted should be set to switch on normally between ¼ hour and 1 hour before commencement of the occupation of the building, depending on local conditions. The correct setting of the room thermostat can only be determined by experience in cold weather when it should be set to shut off the heaters when a comfortable level of warmth has been achieved. This setting will normally be several degrees below that which would be required with a convective heating system.

## 13 REPLACEMENT OF COMPONENTS

**Warning:** Isolate gas and electrical supplies before carrying out any repair work. Always test for gas soundness with a suitable leak detection fluid.

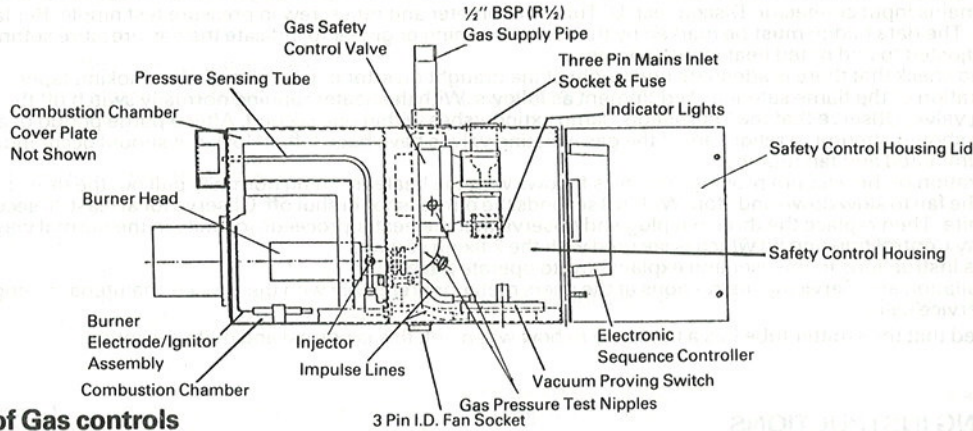

**Fig. 7 Layout of Gas controls (Viewed from Above Burner/Control Assembly)**

### 13.1 To Replace ID Fan

Remove ID fan connecting plug from the burner control assembly. Disconnect flue if fitted. Slacken pinch screw securing fan to emitter tube. Draw fan off tube. Remove three M5 screws securing fan support to fan casing. Refit Support flange to new fan with the pinch bolt facing in the same direction as the fan outlet. Refit the fan to the heater ensuring that the fan discharge faces vertically upwards for flued heaters or horizontally away from the burner for unflued heaters as detailed in fig.1 in these instructions.

### 13.2 To Relace Any Components In The Burner/Control Assembly

This assembly should be removed from the heater by first disconnecting the gas and electrical supplies, the fresh air intake duct if fitted and the fan electrical connection. Slacken the securing pinch screws and draw the burner/control assembly off the emitter tube. When refitting the burner assembly to the heater ensure the box is horizontal.

### 13.3 To Replace Electrode Assembly

Remove top cover of combustion chamber by removing the six dome headed fixing screws taking care not to damage the gasket. Remove the 2BA screws securing the electrode assembly and pull off the two electrode cable connectors. Reconnect the cable connectors to the new electrode assembly ( the two connectors are non interchangeable ) and refit the electrode assembly. Refit the combustion chamber cover plate and rubber gasket. Replace the rubber gasket if this is damaged.

### 13.4 To Replace The Burner Head

Remove combustion chamber cover as in paragraph 13.3. Unscrew burner head from injector taking care not to drop it onto the ignition leads. Refit new burner head and replace combustion chamber cover plate, replacing the rubber gasket if this is damaged.

### 13.5 To Replace The Injector

Refer to 12.5 over page the injector size for Natural Gas 5.0 mm and for Propane 3.4 mm

### 13.6 To Replace Gas Safety Control Valve ( double solenoid and governor Models Honeywell and Teknigas )

Remove combustion chamber cover as in paragraph 13.3 Remove control housing cover by removing the two dome headed fixing screws. Remove burner head as in paragraph 13.4 slacken the support flange grub screw securing the gas pipe nipple and unscrew the 1/2" BSP gas supply pipe entering the gas control valve.

Unplug the gas valve electrical connection marking each connection. The gas valve and injector can now be removed as an assembly. Using an approved pipe joining compound on pipe threads refit the support bracket and pipe fittings onto the replacement control valve. Replace the control valve into the control housing and refit the 1/2" BSP gas supply pipe using a suitable joining compound. N.B. Refit burner onto injector holder before tightening inlet supply pipe support flange grub screw. Carry out commissioning (section 10) setting the burner pressure to that indicated on the data badge.

### 13.7 To Replace The Electronic Sequence Controller

Swing open the safety control housing lid by unscrewing 2 screws. Unplug the electrical connector on the side of the electronic sequence controller. Unplug the single grey wire from the connector on the bulkhead at the side of the electronic sequence controller. Remove the two bolts securing the sequence controller to the control house door and replace the sequence controller using a high tension lead (grey) from an old controller unless its insulation is damaged.

When refitting the Pactrol sequence controller take care that the rear flange of the sequence controller is correctly located underneath the retaining lip in the door of the control housing ( Pactrol P16DI only ). Refit the two bolts and edge connector into the sequence controller and high tension leads into its connector.

### 13.8 To Replace the Vacuum Proving Switch

Disconnect the 2 rubber tube connections at the vacuum switch. Disconnect the three push on connectors from the vacuum switch. Remove the two screws securing the vacuum switch and slip the vacuum switch out of the control housing. Refitting is a reversal of the above taking care to correctly reconnect the three cables. See Fig. 8 below.

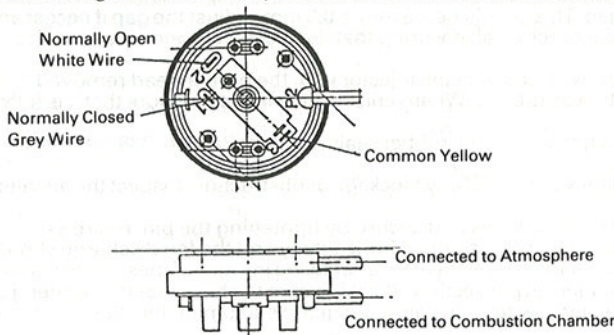

**Fig. 8. Beck Vacuum Proving Switch**

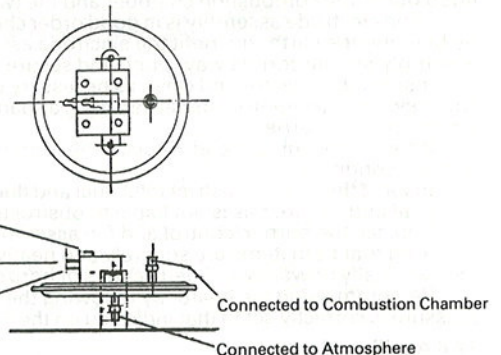

**Fig. 8. Honeywell Vacuum Proving Switch**

### 13.9 To Replace Fuse

Withdraw fuse carrier which is located directly underneath the main electrical input socket, slip the old fuse from the carrier and replace with a new fuse of 1 amp rating

# TROUBLE SHOOTING CHECK LIST

Symptoms	Possible Causes	Remedy
<b>1 BURNER WILL NOT START</b>		
<b>1.1 Red "Mains On" light does not illuminate</b>	a. External controls, thermostat, time switch etc. not calling for heat	Adjust controls
	b. Fuse blown	Check for short circuit in wiring or individual electrical components
<b>1.2 Red light illuminates</b>	a. Fan connector plug not fully engaged	Engage securely
	b. Loose electrical connection.	Check all connections.
	c. Fan seized or burnt out	Replace fan, re-commission heater especially checking gas pressure setting. Check 1.2e below if satisfactory replace sequence controller.
	d. Sequence Controller relay failing to pull in and / or hold in.	
	e. Vacuum switch not returning to normal (switched off) position	Replace vacuum switch
<b>1.3 Fan starts but burner does not attempt ignition</b>	a. Insufficient vacuum generated by fan	Clean fan blades with soft bristle brush.
	b. Blocked emitter tube	Clean emitter tube internally.
	c. Combustion chamber cover permitting air leakage.	Examine condition of rubber gasket, tighten down lid securely.
	d. Vacuum impulse line between combustion chamber and vacuum switch insecure or defective	Fix securely or replace
	e. Vacuum switch does not "pull in".	Replace vacuum switch
	f. Vacuum switch "pulls in" but electronic sequence controller does not proceed to programme ignition sequence.	Replace burner sequence controller unit but first check that the case of failure is not a short on output circuit, by measuring resistance between pins 2 and 7 of burner control unit plug. A reading of less than about 10,000 OHMS indicates short circuit on gas valve burner indicator light or associated wiring
<b>1.4 Burner Control proceeds to ignition stage (normally indicated by audible spark gas valve energised and "burner on" light illuminated) but burner does not light</b>	a. No spark	Check electrode for cracks - replace if necessary. Check high tension - connections are secure. Check spark gap is $3.5 \pm 0.5$ mm. If no high tension output from electronic sequence controller replace controller.
	b. Gas safety control valve burnt out or defective.	Replace solenoid operator section of gas valve.
	c. Insufficient gas pressure.	Set burner pressure to that indicated on the data badge. (see commissioning instructions).
	d. Burner injector blocked.	Clean burner injector.
<b>2 BURNER LIGHTS BUT SHUTS DOWN AFTER A FEW SECONDS</b>		
	a. Inadequate flame signal. This can be varified by connecting a sensitive micrommeter in series with the violet wire which passes through the combustion chamber bulkhead. The correct reading should be $5\mu A \pm 1\mu A$ .	Replace flame electrode. Check connections to electrodes and terminal 4 of electronic sequence controller plug. Replace the electronic sequence controller.
	b. Flame unstable.	Check cleandliness of burner and set burner pressure as per section 5.
	c. Inadequate gas supply. Observe burner gas pressure with all heaters operating.	If gas pressure drops below that indicated on the data badge. Examine gas supply pipework for exsessive pressure loss
	d. Insufficient vacuum at combustion chamber causing vacuum switch to cut off.	Clean fan blades with soft bristle brush. Inspect tube internally and clean if necessary (see servicing servicing instructions ).
<b>3 HEATER SHUTS DOWN AFTER OPERATING FOR A PERIOD OF TIME</b>		
	Refer to 2a and 2d.	If problem persists, replace vacuum switch.

# SPARE PARTS LIST

## RADIANT HEATER MODEL AR35

<b>Part No.</b>	<b>Description</b>
105	Emitter Tubes per length, stainless steel 100 mm dia (4 in)
104	Emitter Tubes per length, aluminiumised steel 100 mm dia (4 in)
120	Relector 6ft section
FA35	ID Fan Assembly
270	I.D. Fan
209	Honeywell Vacuum Proving Switch
259	Beck Vacuum Proving Switch
250	P16DI Electronic Sequence Controller
200	Vernitron 22508/005 Electronic Sequence Controller
258	Teknigas Twin Gas Safety Control Valve
204	Honeywell Twin Gas Safety Control Valve
233	Mains input connector and flexible cable
236	Fuse
203	Red and Green Lamp 240/220v
294	Small H.T. Lead
295	Long H.T. Lead
296	Rectification Lead
BA35AR	Burner Assembly
347	Electrode Ignition/Assembly
403	Standard Burner Head
420	Open Port Burner Head
329	Burner Injector
328	Burner Injector Carrier
309	Burner Support casting
338	Burner Gasket
330	Impulse Line Assembly
397	Type 'A' Bracket
398	Type 'B' Bracket
346	U Bend 100 mm dia (4 in)

### **Note**

When ordering spare parts - please order replacement items identical to that item being replaced.

## USERS INSTRUCTIONS FOR AMBI-RAD HEATERS MODEL AR35

AMBI - RAD is an overhead radiant heating system for industrial and commercial buildings. The AMBI - RAD heater is suspended from the roof or mounted at an angle on the wall and heats by radiation in the same way as the sun.

### IMPORTANT :

1. This appliance must only be installed by a competent person in accordance with the requirements of the Gas Safety Regulations and The Health and Safety at Work Act.
2. **THIS APPLIANCE MUST BE EARTHED.**
3. Never rest anything especially ladders, against the heater.

### To Start the AMBI - RAD Heater:

1. First ensure that the gas supply to the heater is turned on.
2. Ensure that the settings of any time - switch and thermostat are such that the heating system will be required to operate.
3. Switch on electrical supply to heater. Mains light, coloured red, will illuminate and ignition sequence will commence.
4. After completion of an air purge period, ignition of the burner will occur and burner light, green will illuminate.
5. If ignition attempt fails, burner sequence controller will lock out with mains light only illuminated.
6. If lock out occurs switch off electrical supply, wait 15 seconds then switch on again. If lock out occurs again switch off heater and call service engineer.

N.B. Heater will have tendency to bow when hot, but this is quite acceptable.

### To Switch Off AMBI - RAD Heater:

Switch off electrical supply to the heater. The burner will shut off and the fan will stop.

If the heater is switched off for periods in excess of one week it is highly recommended that both gas and electrical supplies are turned off.

### Servicing :

To ensure continued efficient and safe operation it is recommended that the heater is serviced regularly by a competent person eg. every year in normal working conditions but in exceptionally dusty or polluted conditions more frequent servicing may be required. The manufacturers whose address is given below offer a maintenance service, details available on request.

Because of our policy of continuous development Ambi-Rad Ltd. reserve the right to vary the equipment specification without notice

# AMBI-RAD

## radiant heating systems

Southern Office  
Unit 18c, Chapman Way  
Haslemere Highbrooms Estate  
Tunbridge Wells, Kent, TN2 3EF  
Tel: (0892) 512760 Fax (0892) 512788

**Ambi-Rad Limited, PO Box 30,  
Enfield Works, Mucklow Hill,  
Halesowen,  
West Midlands B62 8DS, England.**  
Tel: 021-503 0707 Telex: 333003 AMBI G  
Fax: 021-501 2955

Northern Office  
Unit 27, Etherow Industrial Estate,  
Woolley Bridge Road, Hollingsworth,  
Cheshire SK14 8NS  
Tel (04574) 60080 Fax (04574) 60045

AMBI-RAD is the registered trade mark of AMBI-RAD LTD.