

AMBIRAD

AMBIRAD AR SERIES

RADIANT TUBE HEATERS

INSTALLATION AND OPERATING MANUAL



WARNINGS

Nortek Global HVAC (UK) Ltd equipment must be installed and maintained in accordance with the relevant provisions of the Gas Safety (Installations and Use) Regulations 1998 for gas fired products. Due account should also be taken of any obligations arising from the Health and Safety at Works Act 1974 or relevant codes of practice. In addition the installation must be carried out in accordance with the current IEE wiring regulations (BS 7671), BS 6896 (Industrial & Commercial) and any other relevant British Standards and Codes of Practice by a qualified installer. All external wiring MUST comply with the current IEE wiring regulations.

Part No. 700050



Nortek Global HVAC (UK) Limited, Fens Pool Avenue, Brierley Hill, West Midlands, DY5 1QA

Index

- 1 AR and ARE series gas fired radiant tube heaters
- 2 Gas connection
- 3 Standards
- 4 Electrical connection
- 5 Assembly instructions
- 6 Health and safety
- 7 Fixing tubes and brackets
- 8 Fitting reflectors and end caps
- 9 Burner/fan/damper assembly
- 10 AR and ARE series double linear gas radiant tube heaters
- 11 HB and DL damper settings
- 12 Installation – suggested methods of heater suspension
- 13 Flue connection
- 14 Fresh air ducted inlet *(all models)*
- 15 Commissioning for individually flued and unflued heaters
- 16 Routine service
- 17 Replacement of components
- 18 Trouble shooting checklist
- 19 User instructions for Ambi-Rad AR and ARE series of heaters

1 AR and ARE series gas fired radiant tube heaters

These heaters are for use on natural gas (G20) at a maximum supply pressure of 25 mbar and propane (G31) at a maximum supply pressure of 45 mbar in G.B and I.E.

2 Gas connection

The gas connection on the Ambi-Rad heater is R $\frac{1}{2}$ (1/2in B.S.P internal thread).

Natural gas (I_{2H})

Max supply pressure	25 mbar
Min supply pressure	17 mbar

Propane (I_{3p(37)})

Max supply pressure	45 mbar
Min supply pressure	25 mbar

Propane (I_{3p(50)})

Max supply pressure	57.5 mbar
Min supply pressure	42.5 mbar

Correct gas burning pressure is indicated in the table below.

Correct gas pressure

AR U Tubes Heaters

Model	Natural Gas G20	Propane G31
AR13	8.4mbar	32.9mbar
AR13QB	8.1mbar	35.2mbar
AR22	11.6mbar	31.6mbar
AR35	10.0mbar	34.0mbar
AR40	10.4mbar	28.4mbar
AR45	9.5mbar	28.0mbar
AR50	5.8mbar	28.0mbar

ARE U Tubes Heaters

Model	Natural Gas G20	Propane G31
ARE13	8.4mbar	32.9mbar
ARE22	12.5mbar	31.6mbar
ARE35	12.9mbar	34.0mbar
ARE40	12.7mbar	28.4mbar
ARE45	10.7mbar	28.0mbar
ARE50	5.6mbar	28.0mbar

3 Standards

Ambi-Rad heaters must be installed in accordance with the relevant provisions of the Gas Safety (Installations and Use) Regulations 1998. Due account should also be taken of any obligations arising from the Health and Safety at Works etc. Act 1974. In addition the installation must be carried out in accordance with the current I.E.E. 1992 (BS 7671), BS 6896:1991 (Industrial & Commercial for Flued Appliances) BS EN 13410:2001 (Unflued Appliances and IGE/UP/1) and any other relevant British Standards and Codes of Practice.

A gas meter is connected to the service pipe by the local gas region or local gas region contractor. An existing meter should be checked preferably by the Gas Region or local Gas Region Contractors to ensure that the meter is adequate to deal with the rate of gas supply required. Installation pipes should be fitted in accordance with BS 6891:1988, such that the minimum pressure at least, as stated in section 2 will be achieved and any

other British Standards and Codes of Practice. Pipes of smaller size than the heater inlet gas connection should not be used. The complete installation must be tested for soundness as described in the previous standard.

The gas supply must not be in the position where it is subject to overheating.

The gas union service cock **MUST** be fitted in the gas supply close to the heater, but not onto the burner itself.

It is essential to provide some flexibility in the final gas connection by use of a tested and certified metallic hose to BS 6501 Part 1:1991 (minimum acceptable quality Type 'B' Class 1). When stainless steel flexible hoses are used the hose should be connected in a 180° bend without any strain or torsion. (See figure 1).

Note Take care when making a gas connection to the heater not to apply excessive turning force to the internal controls.

AR SL Single Linear Heaters

Model	Natural Gas G20	Propane G31
AR13	8.4mbar	32.9mbar
AR13QB	8.1mbar	35.2mbar
AR22/24'	10.7mbar	31.6mbar
AR22/27'	11.6mbar	31.6mbar
AR22/32'	10.7mbar	31.6mbar
AR22/36'	10.7mbar	31.6mbar
AR35/33'	13.7mbar	36.6mbar
AR35/42'	11.2mbar	36.6mbar
AR35/50'	11.2mbar	36.6mbar
AR40/42'	11.3mbar	28.6mbar
AR40/50'	11.3mbar	28.6mbar
AR45/50'	10.1mbar	29.6mbar
AR45/60'	10.1mbar	29.6mbar
AR50/50'	5.8mbar	24.2mbar
AR50/60'	5.8mbar	24.2mbar

ARE SL Single Linear Heaters

Model	Natural Gas G20	Propane G31
ARE13	8.4mbar	32.9mbar
ARE22	12.5mbar	31.6mbar
ARE35/42'	13.7mbar	36.6mbar
ARE35/50'	13.7mbar	36.6mbar
ARE40/42'	12.7mbar	28.6mbar
ARE45/50'	10.7mbar	29.6mbar
ARE45/60'	10.7mbar	29.6mbar
ARE50/50'	5.6mbar	28.0mbar
ARE50/60'	5.6mbar	28.0mbar

Figure 1 Correct installation of flexible gas connection

Corrugated Flexible Metallic Hose Assemblies to BS 6501 Part 1 1984 Class 1 Type C Construction
1 Metre Long - Ambi-Rad Part No. 6500-2

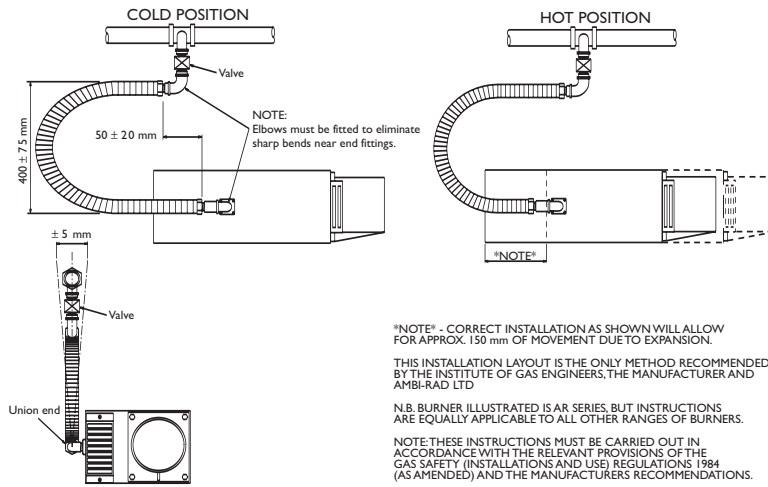

Corrugated Flexible Metallic Hose Assemblies to BS 6501 Part 1 1984 Class 1 Type C Construction
600 mm Long - Ambi-Rad Part No. 6500

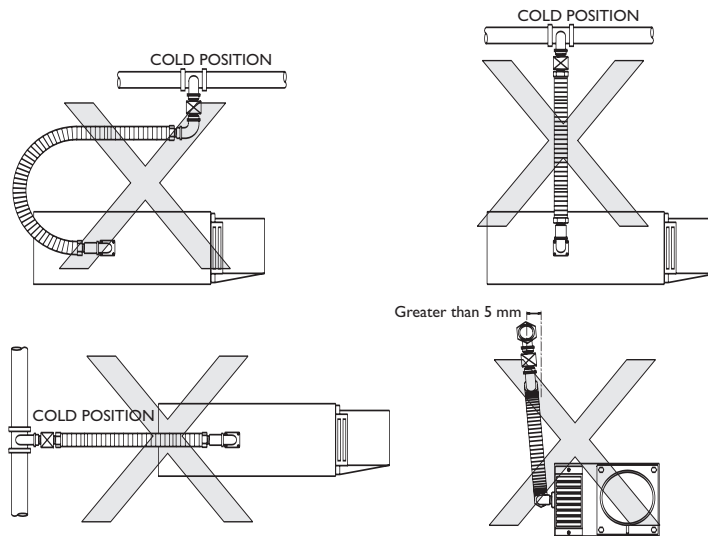
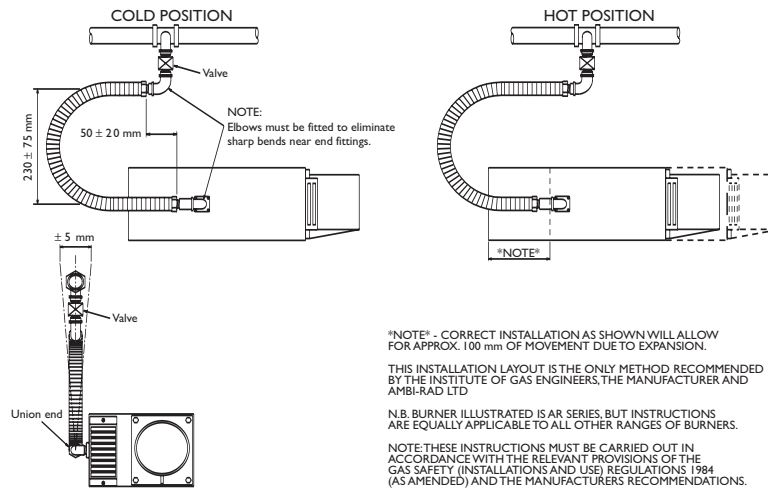

4 Electrical connection



This appliance must be earthed.

Supply 230V 50Hz single phase.
Current rating 0.55 amp max (inductive).
Fuse: external 3 amp.

All electrical work should be carried out to I.E.E. standards by a competent electrician. The electrical connection to the heater is made by means of a three pin plug-in power connector. Live, neutral and earth connections should be made via a flexible supply cable to the power connector and routed clear of the heater or tubes. The flexible supply cables should be of 0.5mm² complying with BS 6500:1990.

Note SL heaters require an electrical cable between the burner unit and the fan assembly. This to be provided by the installing/electrical contractor.



Wiring

The wires in the mains lead are coloured in accordance with the following code:

Green & yellow	Earth
Blue	Neutral
Brown	Live

Instructions for connecting mains lead to plug

Connect green and yellow to plug terminal marked E. Connect blue wire to terminal marked N. Connect brown wire to terminal marked L.

It is recommended that the electrical circuit controlling the heater or group of heaters incorporates thermostats, a time switch and if required, manual control switches and a frost thermostat.

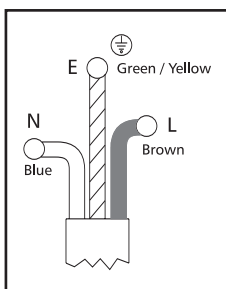

Circuits and controls

All such controls and switchgear must be rated to handle the total inductive load of the circuit they control. Load per Ambi-Rad heater is 0.55 amp. For large installations, the use of relays and contactors should be considered. The method of connection to the electrical supply must facilitate complete isolation and should be made via a fused double pole isolator having a contact separation of at least 3mm in all

poles and supplying the appliance only. Alternatively, connection may be made via a fused three pin plug and unswitched shuttered socket, both complying with the requirements of BS 1361:1971 (1986). Ensure that a copy of the lighting instructions plate is affixed adjacent to the electricity supply switch. Should this switch serve more than one heater it is only necessary to affix one copy per service switch.

Figure 2 Typical wiring connections

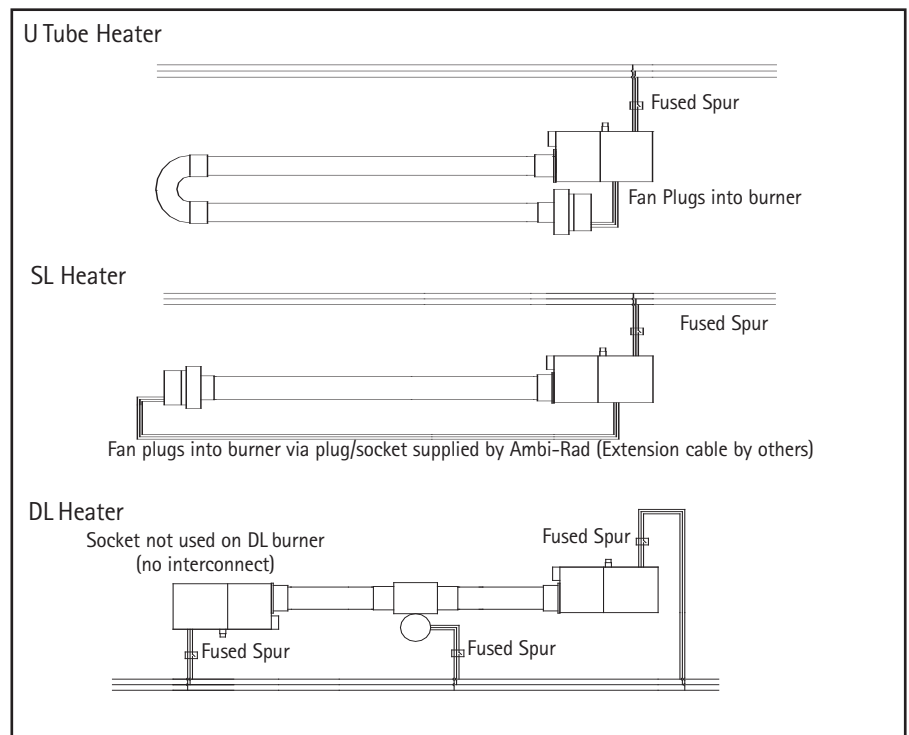

For more comprehensive control arrangements see black bulb and control panel leaflets.

Figure 3 Internal wiring diagram (AR Burner)

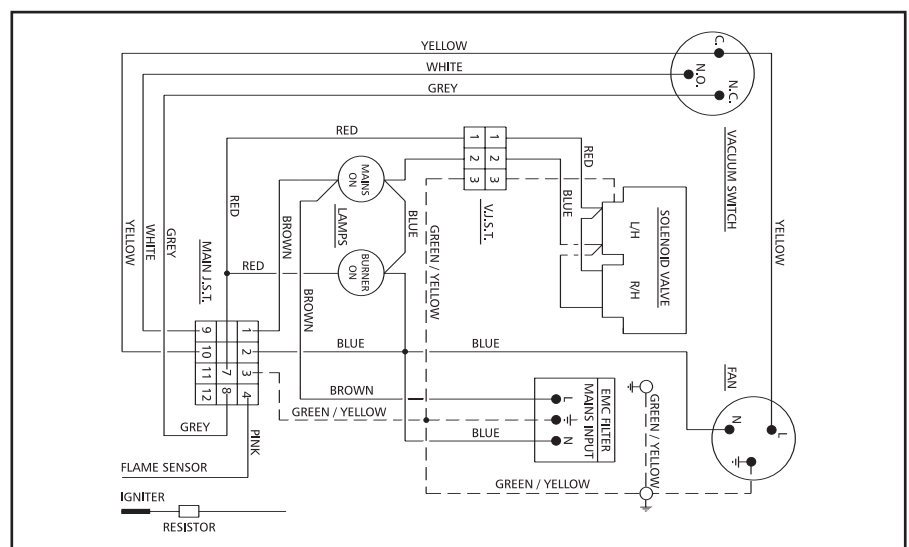

5 Assembly instructions

For assembly drawings and details on specific heaters please refer to the following data sheets.

AR series	Data sheet reference number
AR13 UT/AR13 HB	GB/AR/063/0800
AR22 UT/AR22 HB	GB/AR/064/0103
AR35 Et 40 UT/AR35 Et 40 HB	GB/AR/065/0103
AR45 Et 50 UT/AR45 Et 50 HB	GB/AR/066/0103
AR13 SL/DL HB (22ft)	GB/AR/068/0901
AR22 SL/DL HB (24ft)	GB/AR/069/0901
AR22 SL/DL HB (27ft)	GB/AR/083/0603
AR22 SL/DL HB (32ft)	GB/AR/084/0901
AR22 SL/DL HB (36ft)	GB/AR/087/0901
AR35 SL/DL HB (33ft)	GB/AR/070/0901
AR35 SL/DL HB (42ft)	GB/AR/089/0103
AR35 SL/DL HB (50ft)	GB/AR/093/0103
AR40 SL/DL HB (42ft)	GB/AR/090/0103
AR40 SL/DL HB (50ft)	GB/AR/094/0103
AR45 SL HB (50ft)	GB/AR/096/0103
AR45 SL HB (60ft)	GB/AR/097/0103
AR50 SL HB (50ft)	GB/AR/098/0103
AR50 SL HB (60ft)	GB/AR/092/0103
ARE13 UT/ARE13 HB	GB/ARE/071/0800
ARE22 UT/ARE22 HB	GB/ARE/072/0800
ARE35 Et 40 UT/ARE 35 Et 40 HB	GB/ARE/073/0800
ARE45 Et 50 UT/ARE 45 Et 50 HB	GB/ARE/074/0800
ARE13 SL/DL (22ft)	GB/ARE/075/0901
ARE22 SL/DL HB (27ft)	GB/ARE/076/0901
ARE35 SL/DL HB (42ft)	GB/ARE/077/0901
ARE40 SL/DL HB (42ft)	GB/ARE/078/0901
ARE45 SL HB (50ft)	GB/ARE/099/0901
ARE45 SL HB (60ft)	GB/ARE/100/0901
ARE50 SL HB (50ft)	GB/ARE/101/0901
ARE50 SL HB (60ft)	GB/ARE/091/0901

6 Health and safety

Ambi-Rad Limited cannot be responsible for ensuring that all site safety procedures are adhered to during assembly and installation. Sole liability rests with the installer.

7 Fixing tubes and brackets

'U' tube

General assembly instruction for the;

AR UT/HB

Support radiant tubes on blocks, trestles etc, ensuring the internal welded seam of the tube is facing downwards. Ensure tubes are clear internally.

Push one turbulator into each tube flush with the end adjacent to the return bend (opposite end to the burner and fan). Turbulators are not supplied with any heaters in the AR13 range.

Slip return bend completely onto tubes with the clamping bolts facing upwards. Tighten securely.

Slip the suspension brackets onto the tube assembly.

Position the brackets as shown on relevant data sheet.

AR13 UT/AR13 HB

The AR13 heater has one suspension bracket fitted with reflector locating tabs.

This bracket must be located nearest the burner/open end of the tube assembly.

AR22 UT/AR22 HB

Fit additional centre support bracket onto the tube assembly. 'U' bolts for the centre support bracket and suspension brackets are not interchangeable.

AR35 UT/AR35 HB and AR40 UT/AR40 HB

Identify the difference between the two radiant tubes. The burner tube comprises of half mild steel and half stainless steel. The stainless steel is labelled 'burner end only' and must be installed adjacent to the burner. There are two types of suspension brackets Type 'A' and Type 'B', one of the Type 'A' brackets must be fitted with one standard 'U' bolt and one extra long threaded 'U' bolt. The extra long threaded 'U' bolt with 'stop-nuts' to be located on the stainless steel firing tube as indicated and bolted into position.

Clearance of 3mm must be provided around the tube to allow for thermal expansion. (See Fig 4).

AR45 UT/AR45 HB and AR50 UT/AR50 HB

Identify the difference between the two radiant tubes. The stainless steel burner tube is labelled and weighs less than the return tube. The stainless steel tube must be located on the firing leg only. Join short tube to long tube with swaged joint. One of the Type 'B' brackets must be fitted with one standard 'U' bolt and one extra long threaded 'U' bolt with 'stop-nuts' to be located on the stainless steel firing tube as indicated and bolted into position.

Clearance of 3mm must be provided around the tube to allow for thermal expansion. (See Fig 4).

The above assembly instructions apply to ARE UT/HB series of heaters. However, turbulators are not supplied.

Linear

General assembly instructions for AR SL/HB.

We advise that the tube assembly be built in the roof space where the heater will eventually be situated. This is due to the overall length of the heater, which could be too large for floor assembly.

Referring to the relevant data sheets suspend the brackets as directed.

Insert stainless steel tube into the first two suspension brackets (on some tube lengths the stainless steel tube section may fall short of the second bracket).

Note The stainless steel section is at the burner end of the heater.

Insert the remaining mild steel tube(s) into the remaining brackets to make the overall tube length. Tube sections are attached to each other by means of two 'grub screws' and locking nuts.

Note Do not over tighten the grub screws into the mild steel tube. Finger-tight is sufficient to allow for thermal expansion, but locking nuts must be tightened with a spanner.

When all tubes are connected together, turn the tube assembly so the collar screws and nuts are facing left to right when viewed from the top. Push the turbulator into the end of the tube which is furthest away from where the burner will be located (same end as fan/damper), ensuring it is fully inserted to the location tabs at the end of the turbulator.

Note Fit reflector end-caps before fitting burner assembly and fan assembly. (Not ARE)

Fit the fan/damper assembly onto the mild steel tube (opposite end to where the burner will be located), ensuring it is fully engaged. Secure the pinch screws provided.

Note The above assembly instructions apply to ARE SL/HB series of heaters. However, turbulators are not supplied.

8 Fitting reflectors and end caps

Remove the plastic film from the reflectors.

Note The reflectors are punched at one end.

These holes coincide with the Type 'A' suspension brackets (centre bracket AR22/AR22 HB) with reflector location tabs fitted. The other end of the reflector is free floating to allow for thermal expansion.

'U' tube

AR13 UT/AR13 HB

Affix the single reflector to the locating tabs with M6 nuts, bolts and washers

provided. Fit the reflector end caps using M5 screws, washers and 'S' clips.

AR22 UT/AR22 HB

Insert the two reflectors into the suspension with the punched holes exactly in line with the centre bracket holes. Secure with M6 nuts, bolts and washers provided, passing through both reflector sections. Fit reflector end caps using M5 screws, washers and 'S' clips.

AR35 UT/AR35 HB and AR40 UT/AR40 HB

Position the first reflector section and secure it to the bracket nearest the burner position with M6 nuts, bolts and washers provided. Position the second and third sections so they overlap with the punched holes in line with the tabs on the third suspension bracket from the burner position. The first reflector must lie on top of the second reflector. Secure using M6 nuts, bolts and washers provided, passing through both reflector sections fit reflector end caps using M5 screws, washers and 'S' clips.

AR45 UT/AR45 HB and AR50 UT/AR50 HB

Position first and second reflector sections so they overlap with the punched holes in line with the tabs on the second suspension bracket from the burner and secure using M6 nuts, bolts and washers provided, passing through both reflector sections. Position third and fourth reflector sections so they overlap with punched holes in line with the tabs on the fourth suspension bracket and secure using M6 nuts, bolts and washers provided. Ensure the second reflector is placed over the third reflector. Fit reflector end caps using M5 screws, washers and 'S' clips.

Linear

AR13 SL/HB

Position both reflectors into the brackets so they overlap with the holes coinciding with the locating tabs on the Type 'A' second bracket. Secure using M6 bolts, nuts and large washers passing through both reflector sections and tabs. Fit reflector end caps using M5 screws, washers and 'S' clips.

AR22 SL/HB

Position the first reflector section and secure it with the M6 bolts, nuts and large washers to the Type 'A' suspension bracket nearest

the burner. Position the second and third sections of the reflector so that they overlap with the punched holes in line with the lugs provided on the third suspension bracket from the burner. Secure using M6 bolts, nuts and large washers passing through both reflector sections. Fit reflector end caps using M5 screws, washers and 'S' clips. Ensure the second reflector is placed over the third reflector.

AR35 and 40 SL/HB

Position the first reflector section and secure it with the M6 bolts, nuts and large washers to the Type 'A' suspension bracket nearest the burner. Position the second reflector so they overlap with the punched holes in line with the tabs provided on the third suspension bracket from the burner. Position the fourth reflector in the fourth bracket, and attach the reflector to the fifth bracket. Secure using M6 bolts, nuts and large washers passing through both reflector sections where appropriate. Fit reflector end caps using M5 screws, washers and 'S' clips. Ensure the second reflector is placed over the third reflector.

AR45 and 50 SL/HB

Position the first reflector section and secure it with the M6 bolts, nuts and large washers to the Type 'A' suspension bracket nearest the burner. Position the second and third section of reflector so that they overlap with the punched holes in line with the tabs provided on this suspension bracket from the burner. Where required, fit fifth and sixth reflector sections to sixth and seventh brackets. Secure using M6 bolts, nuts and large washers passing through both reflector sections where appropriate. Fit reflector end caps using M5 screws, washers and 'S' clips. Ensure the second reflector is placed over the third reflector.

Note The above assembly instructions apply to ARE SL/HB series of heaters. However, end caps are not supplied.

9 Burner/fan/damper assembly

Slide the burner control assembly onto the right hand tube (when viewed from the open ends of the tubes) ensuring it is fully engaged.

Note For both horizontal and inclined mounting the burner assembly must be perfectly horizontal with the burner indicating lights facing downwards.

Slide fan/damper assembly onto left hand tube ensuring it is fully engaged. The fan discharge outlet should face vertically upwards if heater is to be individually flued upwards or horizontally away from burner if unflued.

Where the damper assembly is fitted the damper blade must be in the vertical plane. Secure with pinch screw.

Figure 4 Fixing brackets

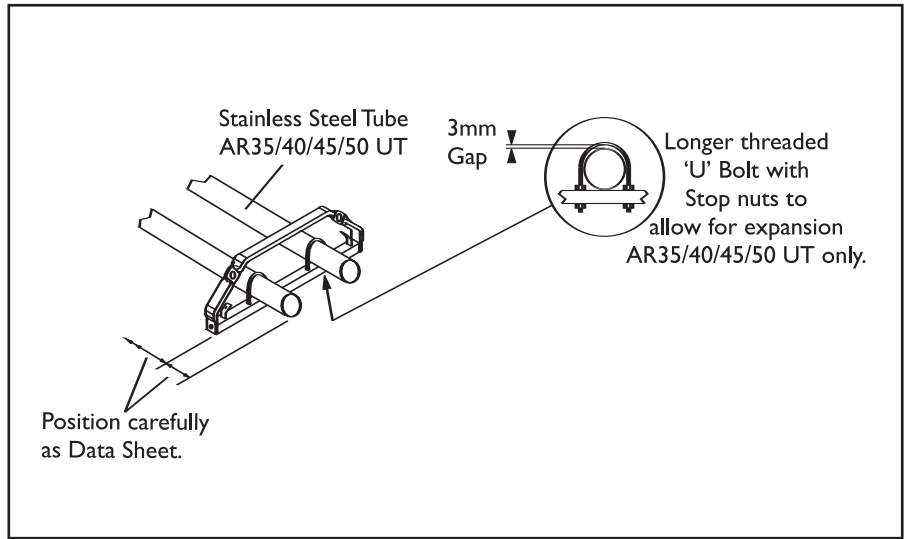

Figure 5 Type 'A' and Type 'B' brackets

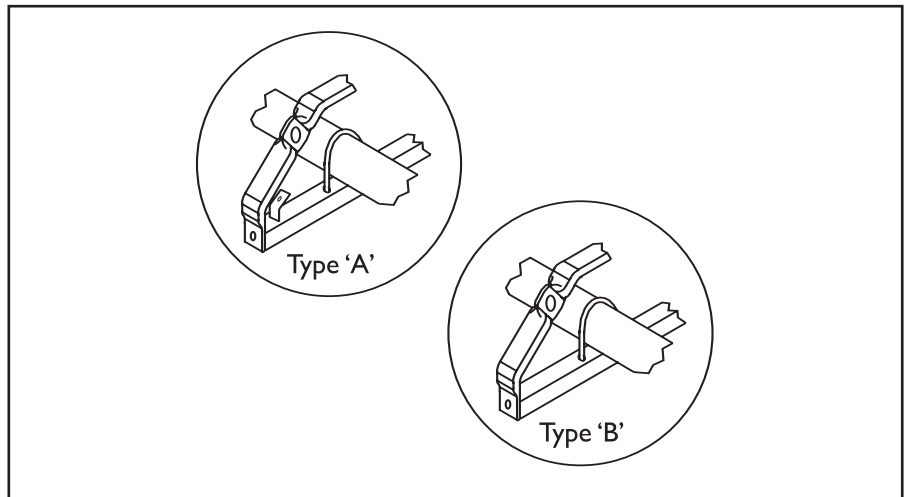

Figure 6 Swaged joint detail

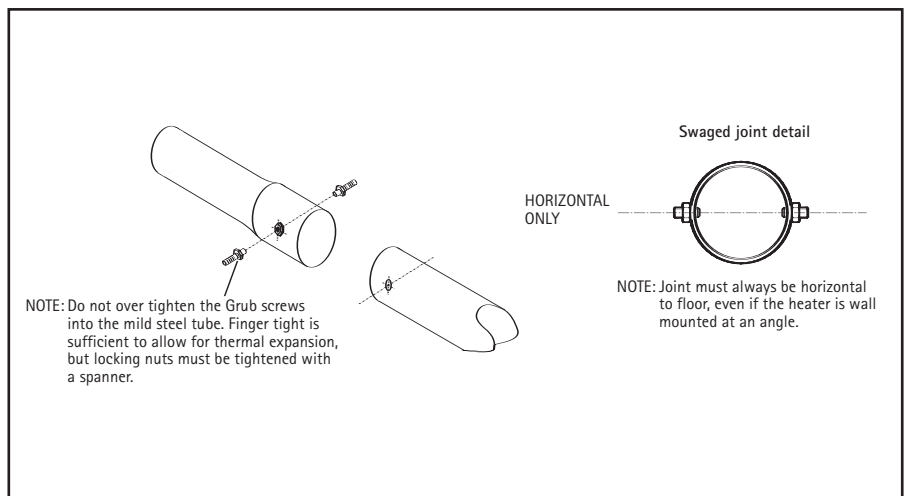
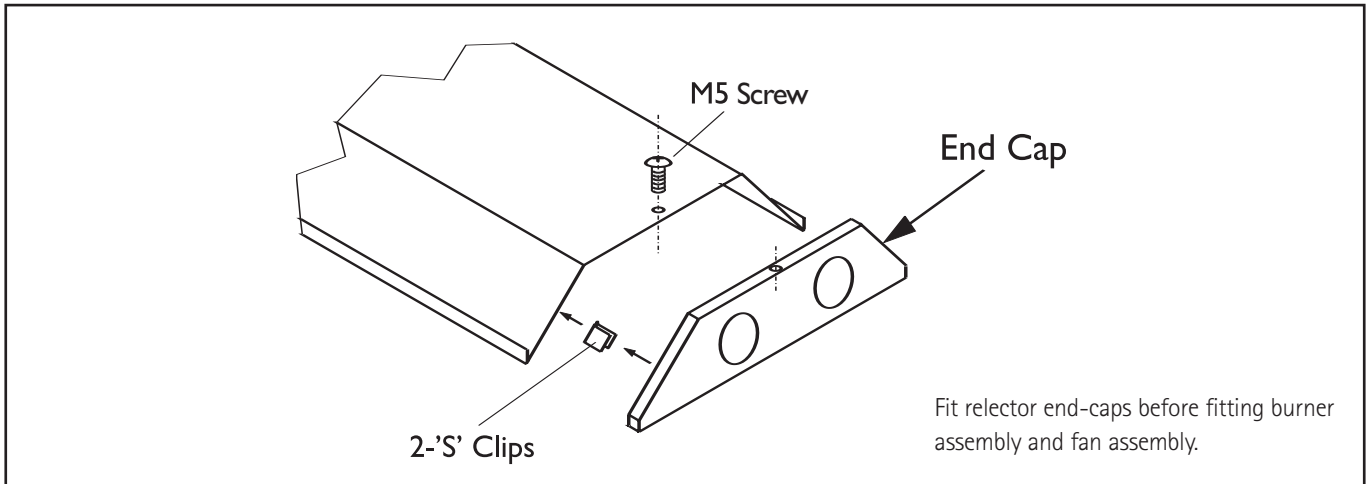

Figure 7 Fitting reflector end caps



Fit reflector end caps using M5 bolts, washers and 'S' clips. (Not applicable to ARE range)

Note Do not stand on reflectors when removing plastic film.

Figure 8 Inclined mounting – unflued

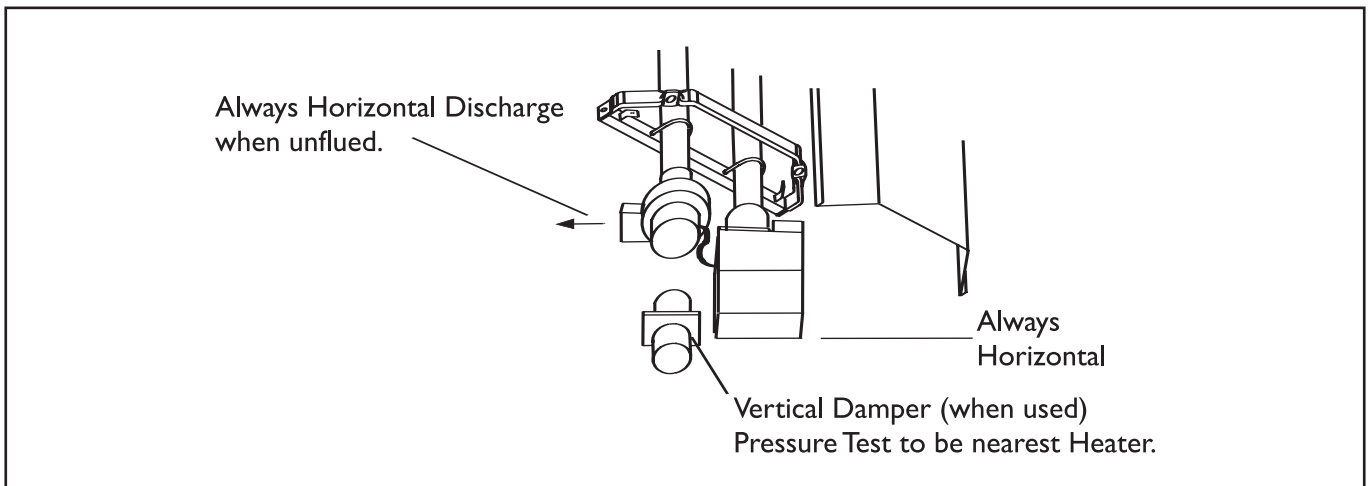
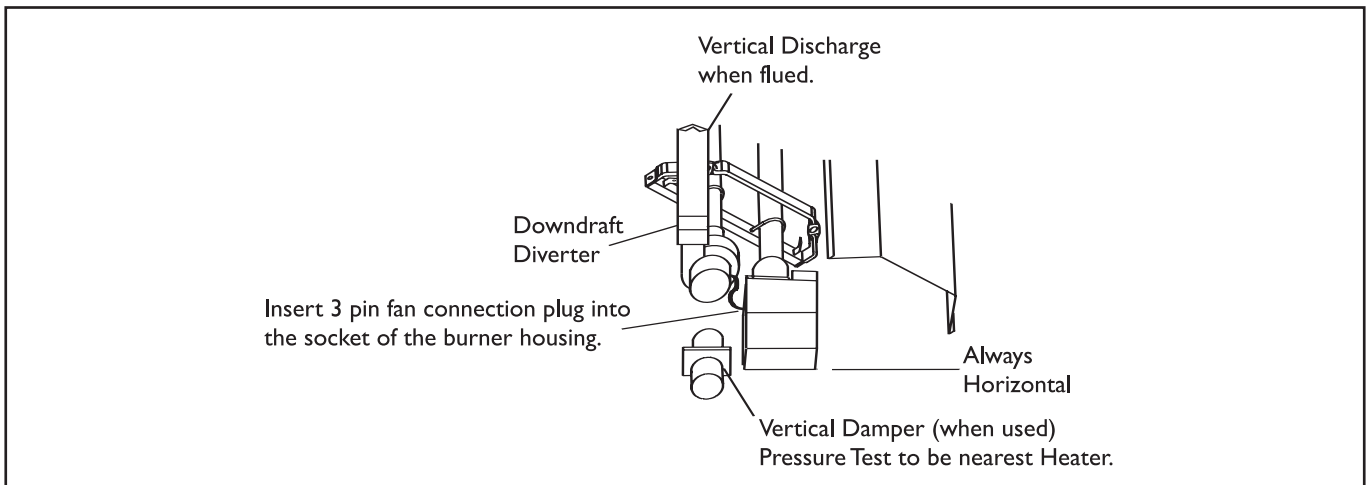

Figure 9 Inclined mounting – flued



10 AR and ARE series double linear gas radiant tube heaters

For double linear heaters refer to the relevant SL data sheet.

Effectively a DL heater comprises of two identical SL heaters with the fan being replaced by a condensate box and fan combined in one unit.

Bracket positions, reflectors and turbulators remain consistent with SL models.

For total overall lengths and weights of DL heaters refer to the table below. For damper settings refer to the table on p11 section 11.

Installation should be carried out in the roof space due to the length of the heaters. Refer to the SL data sheet for bracket positions and reflector installation.

Data is shown for all DL heaters.

Figure 10 Condensate box arrangement

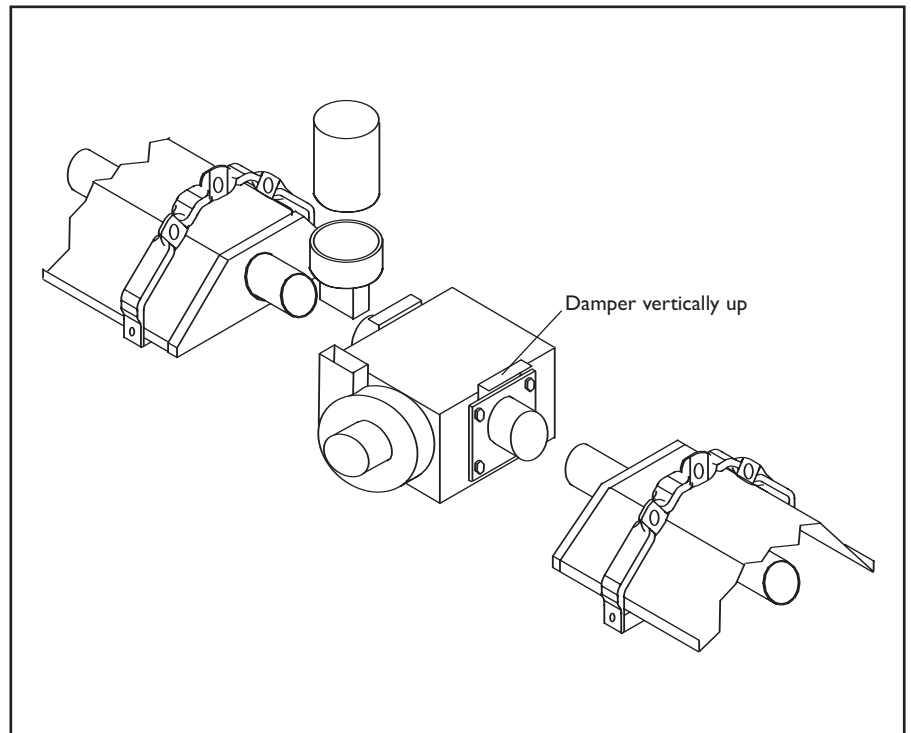

Model	O/A length (m)	Total installed weight (kg)	SL data sheet reference
AR13 DL (22ft)	13.26	112	GB/AR/068/0901
AR22 DL (24ft)	15.0	128	GB/AR/069/0901
AR22 DL (27ft)	16.0	144	GB/AR/083/0603
AR22 DL (32ft)	19.0	170	GB/AR/084/0901
AR22 DL (36ft)	21.0	192	GB/AR/087/0901
AR35 DL (33ft)	20.0	184	GB/AR/070/0901
AR35 DL (42ft)	25.0	234	GB/AR/089/0103
AR35 DL (50ft)	30.0	280	GB/AR/093/0103
AR40 DL (42ft)	25.0	234	GB/AR/090/0103
AR40 DL (50ft)	30.0	280	GB/AR/094/0103
ARE13 DL (22ft)	13.26	112	GB/ARE/075/0901
ARE22 DL (27ft)	16.0	144	GB/ARE/076/0901
ARE35 DL (42ft)	25.0	234	GB/ARE/077/0901
ARE40 DL (42ft)	25.0	234	GB/ARE/078/0901

Figure 11 Typical double linear arrangement

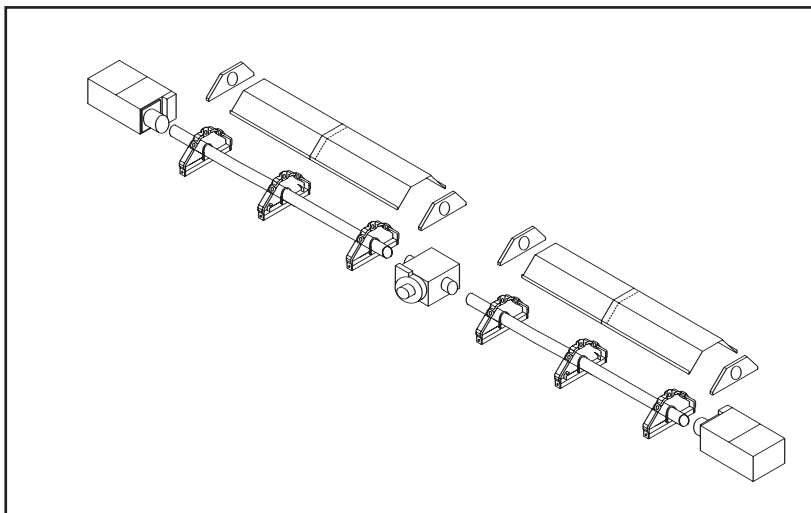

11 HB and DL damper settings

AR Linear Herringbone & DL Heaters

Heater type	Damper setting when hot (mbar)
AR13SHN/22	1.7
AR13SHP/22	1.7
AR22SHN/24	1.4
AR22SHP/24	1.4
AR22SHN/27	1.4
AR22SHP/27	1.4
AR22SHN/32	1.4
AR22SHP/32	1.4
AR22SHN/36	1.4
AR22SHP/36	1.4
AR35SHN/33	1.5
AR35SHP/33	1.5
AR35SHN/42	1.2
AR35SHP/42	1.7
AR35SHN/51	1.0
AR35SHP/51	1.5
AR40SHN/42	1.6
AR40SHP/42	1.4
AR40SHN/51	1.9
AR40SHP/51	1.9
AR45SHN/50	1.9
AR45SHP/50	2.0
AR45SHN/60	2.0
AR45SHP/60	2.3
AR50SHN/50	1.9
AR50SHP/50	2.0
AR50SHN/60	2.0
AR50SHP/60	2.3

AR U Tube Herringbone Heaters

Heater type	Damper setting when hot (mbar)
AR13UHN	1.9
AR13UHP	1.9
AR22UHN	1.6
AR22UHP	1.6
AR35UHN	1.7
AR35UHP	1.7
AR40UHN	1.8
AR40UHP	1.8
AR45UHN	2.2
AR45UHP	2.2
AR50UHN	2.2
AR50UHP	2.2

ARE Linear Herringbone & DL Heaters

Heater type	Damper setting when hot (mbar)
ARE13SHN/22	1.1
ARE13SHP/22	1.1
ARE22SHN/27	1.1
ARE22SHP/27	1.1
ARE35SHN/42	1.0
ARE35SHP/42	1.0
ARE40SHN/42	1.4
ARE40SHP/42	1.4
ARE45SHN/50	1.6
ARE45SHP/50	1.6
ARE45SHN/60	1.9
ARE45SHP/60	1.6
ARE50SHN/50	1.8
ARE50SHP/50	2.3
ARE50SHN/60	1.8
ARE50SHP/60	2.3

ARE U Tube Herringbone Heaters

Heater type	Damper setting when hot (mbar)
ARE13UHN	1.3
ARE13UHP	1.3
ARE22UHN	1.3
ARE22UHP	1.3
ARE35UHN	1.4
ARE35UHP	1.4
ARE40UHN	1.6
ARE40UHP	1.6
ARE45UHN	2.0
ARE45UHP	2.0
ARE50UHN	2.0
ARE50UHP	2.0

12 Installation – suggested methods of heater suspension



Health and safety

Attachment to the heater bracket support lugs should be made by either a 'speed link', D shackle, nut bolt and large washers, or in the case of drop rods, a closed formed hook. Due allowance must be made for thermal expansion of the heater. The hanging attachments to overhead steelwork etc. must be purpose made to good sound engineering practice or of a proprietary type fixing.

They must be adequately fixed and designed to carry the whole weight of the heater and to permit free movement due to linear expansion.

In the event of suitable roof steelwork not being available, additional steelwork should be fitted to enable vertical hangers to be used for suspending the heaters.

If there are any doubts as to the strength or suitability of roof steelwork to which heaters are to be suspended, please refer to Consultant/Architect/owner of the building.

The recommended minimum and preferred mounting heights for the Ambi-Rad heaters are as below.

The recommended clearance to combustibles are shown in the table opposite.

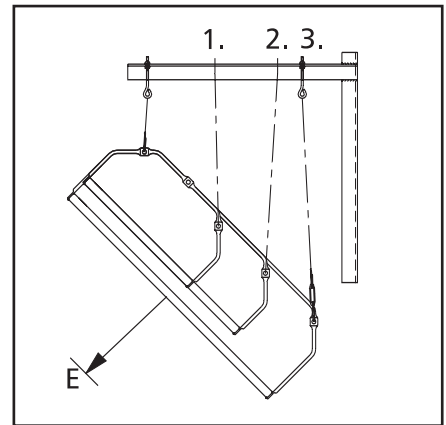
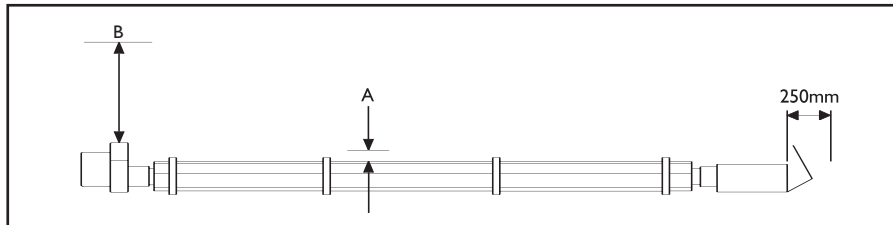
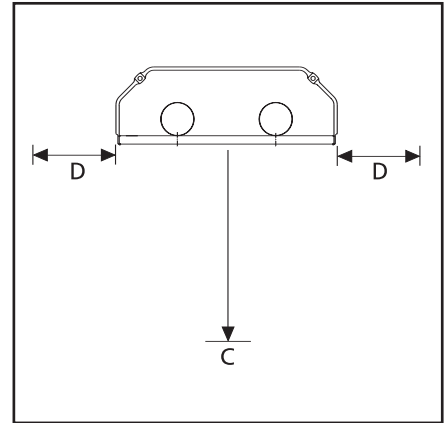

Model AR/ARE	Required angle	Chain length	Eye bolt position
13 'U' tube	45°-60°	8 links	2
	30°-35°	5 links	2
22 'U' tube	45°-60°	14 links	2
	30°-35°	8 links	2
35-50 'U' tube	60°	24 links	3
	45°	18 links	3
	30°-35°	15 links	3

Note Component available pre-drilled Part No WMB-13-22-38

Mounting heights

Model	Mounting position	Minimum mounting height (m)	Recommended mounting height range (m)	When mounting over these heights contact Ambi-Rad design office (m)
AR/ARE13	Horizontal	3.0	3.3 to 4.2	over 4.2
AR/ARE13	Inclined/wall mounted	2.7	3.0 to 4.0	
AR/ARE22	Horizontal	3.6	4.8 to 7.0	over 7.0
AR/ARE22	Inclined/wall mounted	3.0	4.2 to 4.9	
AR/ARE35	Horizontal	4.3	4.9 to 11.0	over 11.0
AR/ARE35	Inclined/wall mounted	3.6	4.0 to 7.0	
AR/ARE40	Horizontal	4.3	4.9 to 11.0	over 11.0
AR/ARE40	Inclined/wall mounted	3.6	4.0 to 7.0	
AR/ARE45	Horizontal	5.0	5.9 to 12.0	over 12.0
AR/ARE45	Inclined/wall mounted	4.3	5.0 to 8.0	
AR/ARE50	Horizontal	5.7	6.9 to 13.0	over 13.0
AR/ARE50	Inclined/wall mounted	5.0	6.0 to 9.0	

Clearance distances

Model	AR/ARE13	AR/ARE22	AR/ARE35	AR/ARE40	AR/ARE45	AR/ARE50
A Above reflector	150	150	150	150	150	150
B Above burner fan assembly flued	500	500	500	500	500	500
C&E Beneath tubes	1250	1250	1500	2100	2100	2100
D To the sides	600	600	600	600	600	600
B From fan outlet unflued	1200	1200	1200	1200	1200	1200

All dimensions are in millimetres.

We recommend that at this stage the tube assembly is raised into position and suspended by its two end brackets only from previously fixed chains, of 4mm gauge galvanised welded link construction or fixed to two wall mounting brackets which must incorporate a short section of hanging chain to allow movement due to thermal expansion.

Alternatively 10mm diameter mild steel drop rods can be used. Wall mounting brackets must support the heater at an angle of inclination of between 35° and 55° and are available from the manufacturer. The angle is varied by adjusting the drop rods or chain on each bracket. These bracket positions are critical and when suspended, must have the same orientation i.e. all the same angle.

UT only

Note If the heater is to be wall mounted the return bend must be on the left hand side when viewed facing the wall, with the burner fitted to the tube nearest the floor.

Figure 12 Methods of heater suspension

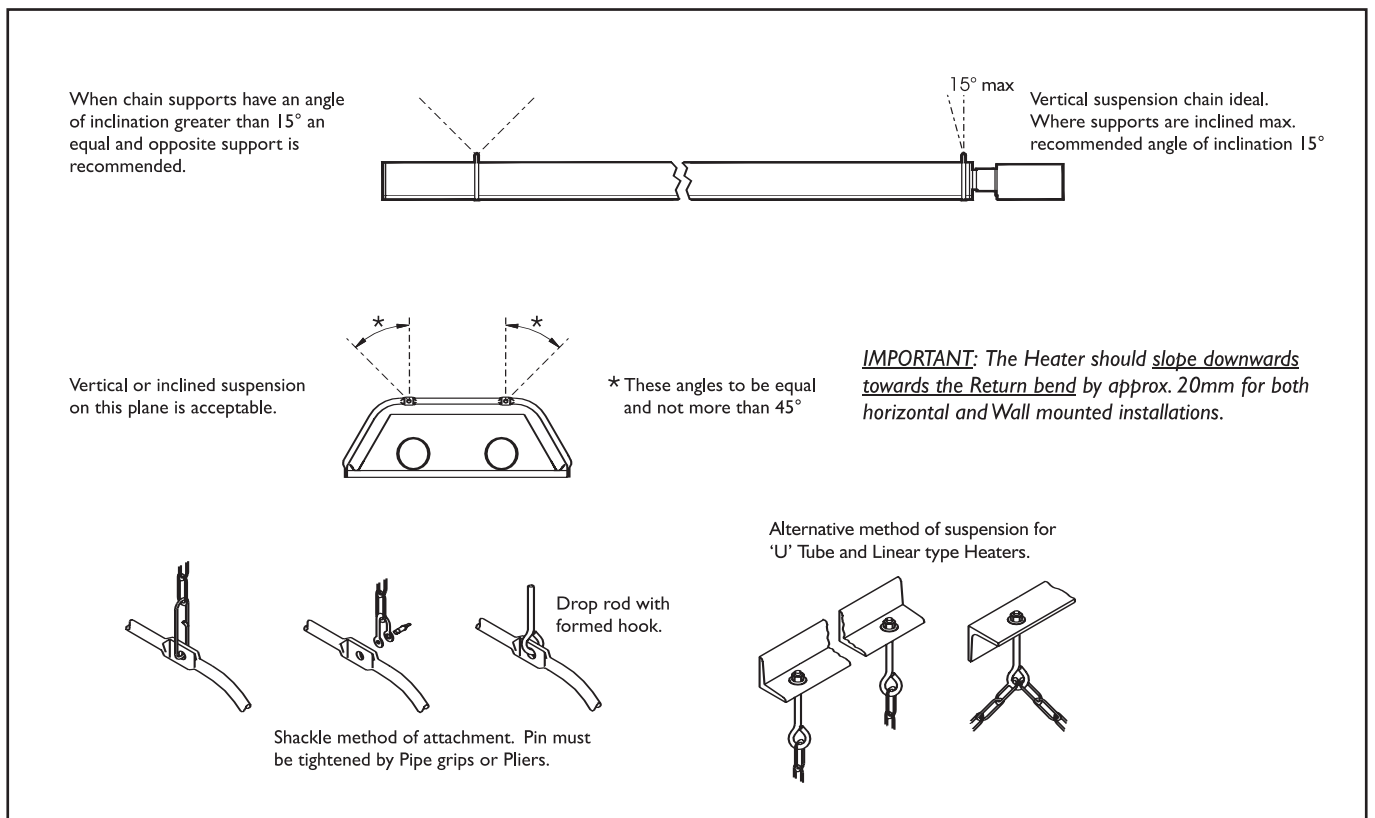

Figure 13 Mounting of 'U' tube heater

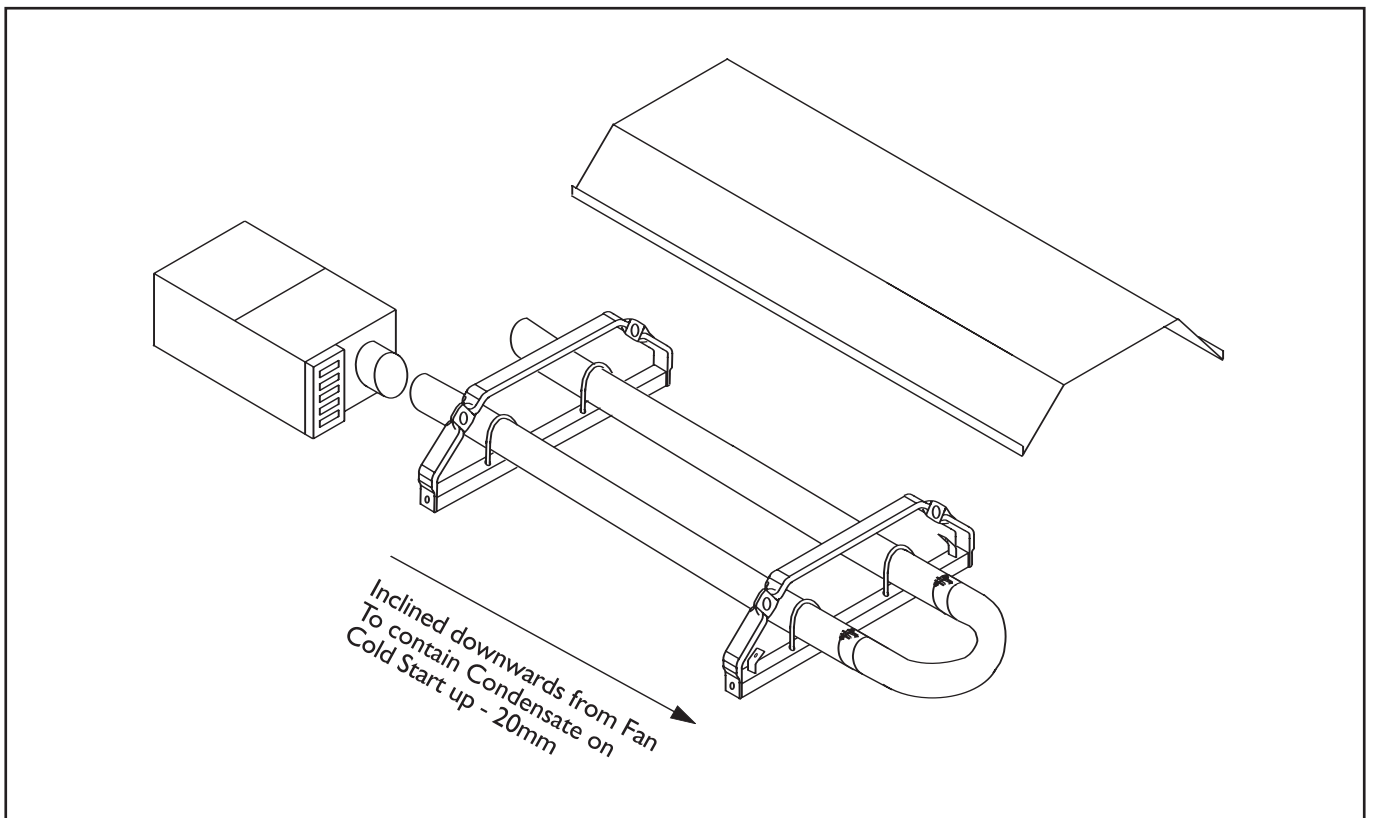
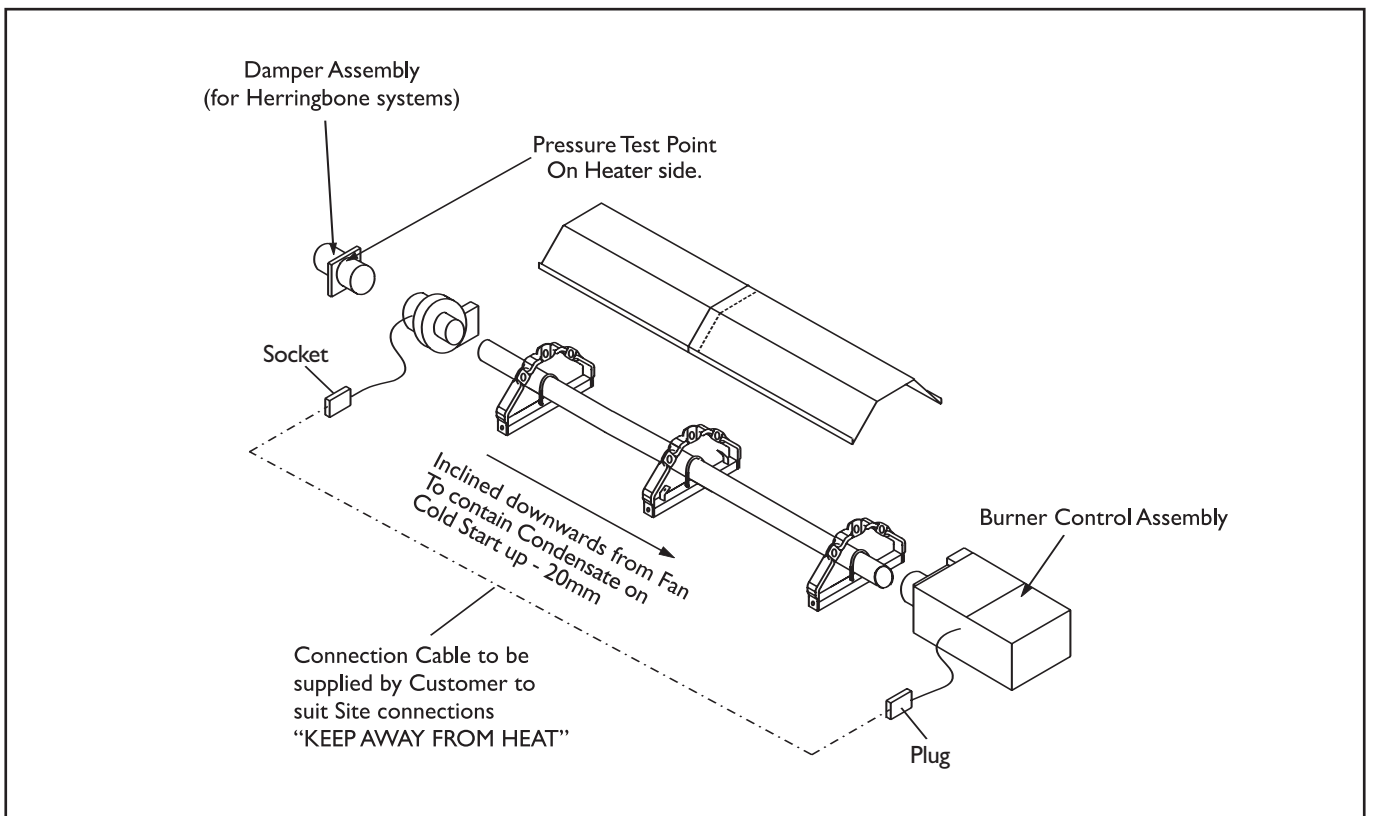

Figure 14 Mounting of 'SL' tube heater



13 Flue connection

The Ambi-Rad heater may be installed with or without a flue to atmosphere providing the air supply and building ventilation requirements as stated in BS 6896:1991 complied with and providing due consideration is given to the possibilities of condensation forming on cold surfaces when used as an unflued heater.

Unflued installation

Permanent ventilation required is as follows:

Natural ventilation

(to be fitted at high and low level with minimum distance between of 3m).

Low level, when air change rate is less than 33m³/h/kW of total rated input, either: 1.4cm² for each 1m³/h/kW below 33m³/h/kW or 46cm²/kW of total rated input.

High level, above areas where personnel are working is as above.

Mechanical ventilation

Minimum proven air flow is 33m³/h/kW of total rated heated input.

If the heater is installed without a flue, ensure that combustion gases do not impinge on combustible materials. The maximum permitted temperature for such materials is 50°C, EN416.

Flued installation

The Ambi-Rad heater may be installed with a flue. A down-draught diverter (supplied as an optional extra by the manufacturer) must be fitted to the induced draught fan exit by means of the screws and clamp plates provided. The diverter is designed to accept a 125mm (5in) nominal bore proprietary metal flue pipe complying with BS 715:1993.

The joint should be sealed with heat resistant caulking and faced off with fire cement. A flue pipe should be adequately supported at regular intervals from the building structure and terminated externally with a British Gas Tested and Certified terminal. The maximum flue length is 9m (30ft) and maximum number of bends is two. For individually flued appliances, horizontal runs and 90° bends should be avoided. All connections in the flue pipe must be properly sealed. Permanent ventilation is required as follows:

Natural ventilation

(Preferably at low level)

Up to and including 60kW : 4.5cm²/kW.
Over 60kW : 270cm² + 2.25cm²/kW in excess of 60kW total rated input.

Forced ventilation

Minimum proven air flow is 2.35m³/h/kW of total rated input.

For detailed information please refer to BS 6896:1991, Installation of Gas Fired Overhead Radiant Heaters for Industrial and Commercial Heating (2nd and 3rd family gases).

14 Fresh air ducted inlet (all models)

When the Ambi-Rad heater is to be installed in locations where there is airborne dust or where there is a polluted atmosphere, eg. chlorinated vapours, process dust etc., a ducted fresh air supply must be provided to the burner. Where a fresh air ducted inlet is to be fitted to the burner assembly the stainless steel air intake grill must be removed from the burner casing and the orifice fitted with a blanking off plate.

Note The pressure sensing tube is to be re-positioned to align with the orifice in the ducted fresh air connection of the combustion chamber cover plate (see document reference AR/050/0498 drawing no. ER 3473). (ARE35, AR/ARE40, 45, 50 connection to 90° bend). These models incorporate a 100mm (4in) fresh air duct connection. A fresh air duct of minimum 100mm (4in) diameter should be connected to the combustion chamber cover plate inlet duct. A flexible joining piece should be used, available from the manufacturer, fixed with hose clips to facilitate disconnection when servicing the burner. The maximum length of fresh air inlet duct is 7m (23ft) of 100mm (4in) diameter duct. Maximum number of bends is two.

A position should be selected for the inlet of the fresh air duct such that will receive dust free clean air. A cowl of the British Gas tested and certified type, such as the GCI or GLC terminal, should be fitted at the inlet of the duct. If the duct inlet is located on a roof the underside of the inlet cowl must be at least 600mm (2ft) above roof level and at least

250mm (10in) higher than any projection on the roof within a 2m radius of the cowl. For fresh air ducted inlet heaters, heater model is suffixed with DA to indicate ducted air inlet (eg. AR22 DA).

15 Commissioning for individually flued and unflued heaters

Inspect installation and ensure that it has been carried out in accordance with these instructions. Ensure that electrical and gas supplies are isolated. The gas supply should be purged and tested for soundness in accordance with the BS 6891:1988, BGIM/16, IGE Report 1M/2 and any other British Standard and Codes of Practice. Open isolating valve.

Remove the combustion chamber cover plate or ducted air inlet connection by unscrewing 6 fixing screws. Take care not to damage the sealing gasket. Inspect the burner and electrode assemblies, ensuring these are securely fixed and all electrical connections securely made. Replace the cover plate or ducted air inlet connection, ensuring that the sealing gasket is correctly positioned and the six screws are fully tightened. The heater will not operate until this plate is refitted.

Open the control housing cover door by unscrewing the securing screw. Ensure all internal components are securely fixed and all connections securely made.

Switch on the electrical supply to the heater and observe the correct start up sequence as follows:

The mains lamp (red) will illuminate. The ID fan will start to run and the vacuum switch checking relay (inside flame electronic sequence control box) will pull in. Safe-start checks are carried out automatically and a purge period of approximately 9 seconds will commence.

At the end of the purge period the ignition sequence will commence. The spark ignition will be energised producing a spark at the ignition electrode. The gas shut off valve will at the same time be energised. If ignition is successful the flame is detected by the flame sensing probe and the ignition spark will be switched off. The 'burner on' (amber) lamp indicates that the gas safety control valves are energised.

If the ignition is unsuccessful the gas safety control valve is closed and the spark ignition de-energised after approximately 5 to 7 seconds. After an unsuccessful ignition attempt the electronic sequence controller will 'lock-out'. The 'power lamp' (red) only will remain illuminated and the fan will continue to run. To reset this 'lock-out' condition, switch the power supply to the heater, wait 15 seconds then restore it. If repeated lock-out occurs investigate cause.

In the event of an electrical fault after installation of the appliance preliminary electrical systems checks should be carried out (re-earth continuity polarity and resistance to earth).

To shut down the heater, switch off the power supply to the heater. Automatic control of the heater or a series of heaters may be achieved by incorporating thermostats, time switches, frost thermostats, manual over-ride switches etc., in the electrical supply to the heater(s). It is essential to allow a delay of 15 seconds after switching off a heater before attempting to restart.

If at any time after completion of the start up sequences, loss of flame should occur, the electronic sequence controller will attempt to re-ignite. If this is unsuccessful lock-out will occur.

Set burner gas pressure as follows. Isolate gas supply. Unplug mains input connector to heater. Unscrew the fixing screw in the hinged safety control housing lid and swing away. Remove pressure test point screw nearest the burner head and connect a 'U' tube manometer to the pressure test nipple located on the body of the gas valves.

Remove the slotted cover from the pressure test regulator revealing the adjustable screw. Replace mains input connector and start the heater. Using a suitable screwdriver adjust the pressure regulator. Switch off the heater by pulling out the mains input connector. Disconnect 'U' tube manometer and refit screw in pressure test nipple. Replace cover on pressure regulator. If heater is flued check that there is adequate updraught at the down-draught diverter eg. by means of a smoking taper when heater is running.

Check the operation of the flame safe guard equipment as follows. With the heater running normally, switch off the gas supply at the appliance isolating valve. Observe that the 'burner on' lamp extinguishes within one second. After a purge period of approximately 9 seconds the heater should attempt to re-light and if the gas isolating valve has been left off, lock-out should occur indicated by power light only being illuminated and fan running.

Check the operation of the vacuum proving switch as follows. With the heater running normally pull out the three pin fan connection plug, thus causing the fan to slow down and stop. Within 3 seconds the burner should shut off. Observe for at least 20 seconds that there is no attempt to re-ignite, then replace the three pin plug and observe that the heater proceeds to ignite in the normal way.

Close the safety control housing lid which is secured with the fixing screw.

Hand the 'User Instructions' to the user and explain how to operate the heater.

Leave the 'Installation and Servicing Instructions' at the user's meter or preferably with the service/maintenance engineer/manager for use on future service calls.

Note It will be noted that heaters have a tendency to bow when hot, this is normal and quite acceptable.

16 Routine service

ID fan

Remove ID fan by unplugging the electrical connection from the burner/control assembly and loosening the fan securing pinch screw. If a flue is fitted, this must be disconnected. The fan will now slip off the emitter tube. Inspect the main fan impeller and remove any dust by brushing with a soft brush. Similarly remove any dust from the finger guard covering the secondary (cooling) impeller and the mesh aperture in the motor cover. Ensure that the impeller turns freely and that there is not excessive play in the bearings. Do not replace fan until emitter tube inspection has been completed.

Emitter tube inspection

Brush away any dust on the exterior of the emitter tubes.

Inspect the emitter tubes internally. If there is any appreciable build up of dust or deposits the tubes should be cleaned internally. Remove the burner/control assembly as directed below.

Detach return bend and remove the turbulators where fitted. The two tubes can then be cleaned by passing rods and a suitable scraper through them or by use of an industrial vacuum cleaner with a long extension tube.

Reflector

Although not considered part of an annual routine service, the condition of the reflector should be noted and the user's attention drawn to any cleaning necessary. The reflectors can be simply withdrawn for cleaning by removing the M6 nuts and bolts securing them and sliding them out of the suspension brackets once the reflector end caps have been removed. The reflectors can be cleaned with a soft cloth and detergent in water. A mild non abrasive metal polish may be used in cases of extreme discolouration. Dirty reflectors will increase the heat radiation upwards into the roof space by 3-4%.

Removal of burner/control assembly

Remove the burner/control assembly by disconnecting the gas and electrical supply, fresh air inlet (if fitted) and the fan electrical connection. Slacken the burner fixing pinch screws and draw the assembly off the emitter tube.

Burner/electrode assembly

Inspect the burner electrode assembly by removing six dome head screws securing the combustion chamber's cover plate on top of the burner box, taking care not to damage the sealing gasket. Remove the burner head by unscrewing it from the injector, taking care not to drop it onto the leads of the ignition electrodes. Pepper pot burner heads should be examined every 6 months for signs of debris and cleaned by blowing compressed air in reverse direction to flow. Renew the electrode assembly if it is not in good condition. The assembly is then lifted out of the combustion chamber and the two connection cables disconnected.

If the electrode assembly is in good order check the spark electrode gap. This should be $3.5\text{mm} \pm 0.5\text{mm}$. Adjust the gap if necessary by bending the earth rod. Refit the electrode assembly in the reverse order of removal, ensuring that the electrical connections to the assembly are the correct way round and secure.

Inspect the injector and clean as necessary. Do not broach out. To remove the injector with the burner head removed, unscrew the injector from its carrier using a spanner on the hexagon portion of its body. When replacing the injector ensure that it is fully tightened in its carrier. Replace the burner head. Replace the combustion chamber plate cover, renewing the sealing gasket if this is not in good condition.

17 Replacement of components

Health and safety

Isolate gas and electrical supplies before carrying out any repair work. Always test for gas soundness with a suitable leak detection fluid.

To replace ID fan

Remove ID fan connecting plug from the burner control assembly. Disconnect flue if fitted. Slacken pinch screw securing fan to emitter tube. Draw fan off tube. Remove three M5 screws securing fan support to fan casting. Refit support flange to new fan with the pinch bolt facing in the same direction as the flue outlet. Refit the fan to the heater, ensuring that the fan discharge faces upwards for flued heaters or horizontally away from the burner for unflued heaters.

To replace any components in the burner/control assembly

This assembly should be removed from the heater by first disconnecting the gas and electrical supplies and the fan electrical connection. Slacken the securing pinch screws and draw the burner/control assembly off the emitter tube. When refitting the burner assembly to the heater ensure the box is horizontal ie. with indicator lamps downwards.

To replace electrode assembly

Remove top cover of combustion chamber by removing the six dome headed fixing screws, taking care not to damage the gasket. Remove the M4 screws securing the electrode assembly and pull off the two electrode cable connectors. Reconnect the cable connectors to the new electrode assembly (the two connectors are non interchangeable) and refit the electrode assembly. Refit the combustion chamber cover plate and sealing gasket. Replace the sealing gasket if this is damaged.

To replace burner head

Remove combustion chamber as above. Unscrew burner head from the injector, taking care not to drop it onto the ignition leads. Refit new burner head and replace combustion chamber cover plate, replacing the gasket if this is damaged.

To replace the injector

Remove burner head as on previous page. Unscrew injector from its carrier using a spanner on the hexagonal portion of its body. When replacing ensure the injector is fully tightened in its carrier. For correct injector size see data badge on heater.

To replace gas safety control valve

(double solenoid and governor models S.I.T., Honeywell and Black/Teknigas). Remove combustion chamber cover as on previous page. Remove control housing cover by removing the two dome headed fixing screws. Remove burner head and the 2 screws holding inlet gas connection supply support plate. Disconnect the gas valve electrical connection, marking each connection. The gas valve and injector can now be removed as an assembly. Using an approved pipe joining compound on pipe threads,

refit the pipe fittings onto the replacement control valve. Replace the control valve into the control housing (refit burner onto injector holder before tightening inlet support plate screws). Carry out commissioning, setting the burner pressure to that indicated on the data badge.

Note Insulated inline connectors are used on Black/Teknigas control valve.

To replace the electronic sequence controller

Swing open the safety control housing cover by unscrewing two screws. Disconnect the electrical connector on the side of the electronic sequence controller. Unplug the single grey high tension lead from the electronic sequence controller. Remove the two bolts securing the sequence controller to the control housing door and replace the sequence controller using the high tension

lead (grey) from the old controller unless its insulation is damaged. When refitting the patrol sequence controller, take care that the rear flanges of the sequence controller are correctly located underneath the retaining lip in the door of the control housing (pactrol P16DIA only). Refit the two bolts and electrical connector into the sequence controller and high tension leads into its connector.

To replace the vacuum proving switch

Disconnect the two silicon rubber tube connections at the vacuum switch. Disconnect the three push on connectors from the vacuum switch. Remove the two screws securing the vacuum switch and slip the vacuum switch out of the control housing. Refitting is a reversal of the above, taking care to correctly reconnect the three cables.

Figure 15 Model AR burner assembly

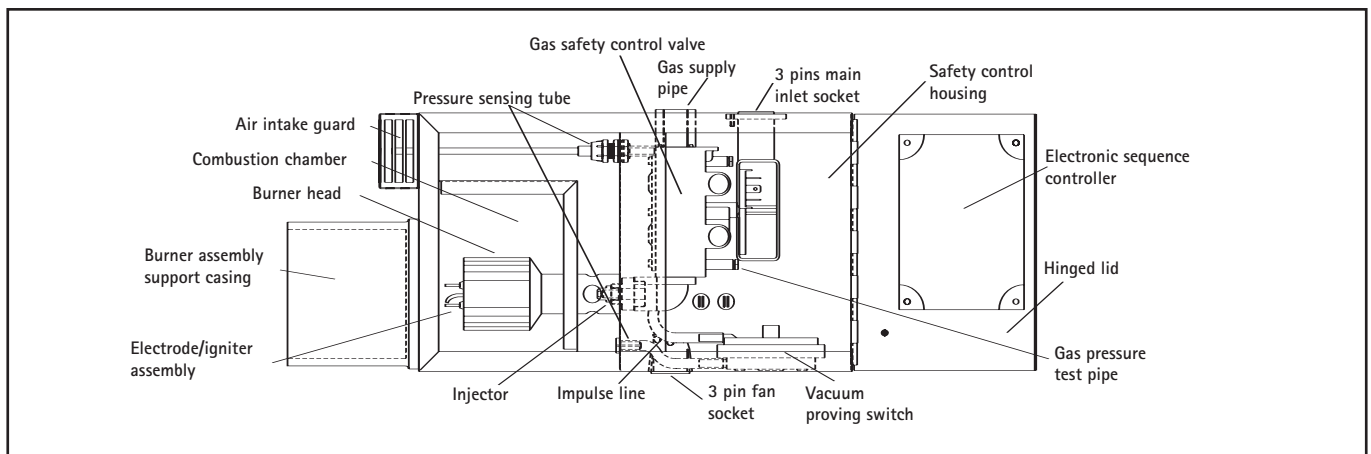
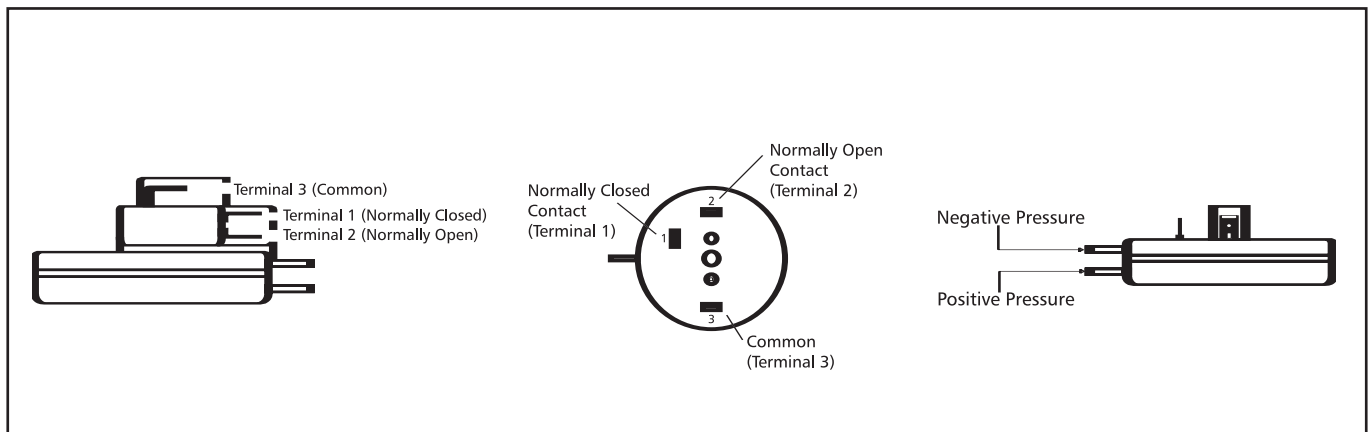

Figure 16 S.I.T. vacuum proving switch



18 Trouble shooting checklist

Symptoms	Possible causes	Remedy
Burner will not start Red 'mains on' does not illuminate.	External controls, thermostats, time switch etc. not calling for heat.	Adjust controls.
	Fuse blown.	Check for short circuit in wiring or individual electrical components.
Red light illuminates.	Fan's connector plug not fully engaged.	Engage securely.
	Loose electrical connection.	Check all connections.
	Fan seized or faulty motor.	Replace fan, recommission heater, checking gas pressure settings.
	Sequence controller relay failing to pull in and/or hold in.	Check vacuum switch is satisfactory, replace sequence controller.
	Vacuum switch not returning to normal (switch off) position.	Replace vacuum switch.
HB Herringbone system only.	Fan tripped out on overload. (Type O fans only)	Check overload setting: single phase 3.1 amp. Reset button on in control panel. Check for build up of condensate in fan casing.
Fan starts but burner does not attempt ignition.	Insufficient vacuum generated by fan.	Clean fan blades with soft bristle.
	Blocked emitter tube.	Clean emitter tube internally.
	Combustion chamber cover permitting air leakage.	Examine condition of sealing gasket, tighten down lid securely.
	Vacuum impulse line between combustion chamber and vacuum switch insecure or defective.	Fix securely in place.
	Vacuum switch 'pulls in' but electronic sequence controller does not proceed to programme ignition sequence.	Replace burner sequence controller unit but first check that the cause of failure is not a short on output circuit, by measuring resistance between pins 2 and 7 of burner control unit plug. A reading of 10,000 ohms indicates short circuit on gas valve burner indicator light or associated wiring.
HB Herringbone system only.	Leaks in joint separation in manifold system.	Reseal or reconnect.
Burner proceeds to ignition stage (normally indicated by audible spark valve energised and 'burner on' light illuminated) but burner does not light.	No spark.	Check electrode for cracks – replace if necessary. Check high tension connections are secure. Check spark gap is 3.5 ± 0.5 mm. If no high tension output from electronic controller, replace controller.
	Gas safety valve faulty or defective.	Replace solenoid operator section of gas valve.
	Insufficient gas pressure.	Set burner pressure to that indicated on data badge (see commissioning).
Burner lights but shuts down after a few seconds.	Inadequate flame signal. This can be verified by connecting a sensitive micrometer in series with the violet wire which passes through the combustion chamber bulkhead. The correct reading should be $5\mu A \pm 1\mu A$.	Replace electrode. Check connections to electrodes and terminal 4 of electric sequence controller plug. Replace the electronic sequence controller.
	Flame unstable.	Check cleanliness of burner and set burner pressure as indicated on data badge.
	Inadequate gas supply. Observe burner gas pressure with all heaters operating.	If gas pressure drops below that indicated on the data badge, examine gas supply pipework for excessive pressure loss.
	Insufficient vacuum at combustion chamber causing vacuum switch to cut off.	Clean fan blades with soft bristle brush. Inspect tube internally and clean if necessary (see servicing instructions).
Heater shuts down after operating for a period of time.	Refer to above.	If problem persists, replace vacuum switch.

19 User instructions for Ambi-Rad AR and ARE series of heaters

Ambi-Rad is an overhead radiant heating system for industrial and commercial buildings. The Ambi-Rad heater is suspended horizontally overhead from the roof or inclined mounted at 35° to 55° from the horizontal and heats by radiation in the same way as the sun.

1 This appliance must only be installed by a competent person in accordance with the requirements of the Codes of Practice or the rules in force.

2 **Warning this appliance must be earthed.**

3 Never rest anything, especially ladders, against the heater.

To start the Ambi-Rad heater

1 First ensure that the gas supply to the heater is turned on.

2 Ensure that the settings of any time-switch and thermostat are such that the heating system will be required to operate.

3 Switch on electrical supply to heater. Mains light, coloured **red** will illuminate and ignition sequence will commence.

4 After completion of an air purge period, ignition of the burner will occur and burner light, coloured **amber**, will illuminate.

5 If lock out occurs, switch off electrical supply, wait 15 seconds then switch on again. If lock-out occurs again switch off heater and call out a service engineer.

Note Heater will have a tendency to bow when hot, this is quite acceptable.

To switch off Ambi-Rad heater

1 Switch off electrical supply to the heater. The burner will shut off and the fan will stop.

2 If the heater is switched off for periods in excess of one week, it is highly recommended that both gas and electrical supplies are turned off.

Servicing

To ensure continued efficient and safe operation, it is recommended that the heater is serviced regularly by a competent person, eg. every year in normal working conditions but in exceptionally dusty or polluted conditions more frequent servicing may be required. The manufacturer, whose address is given below, offers a maintenance service. Details available on request.

NORTEK GLOBAL HVAC (UK) LTD
Fens Pool Avenue
Brierley Hill
West Midlands DY5 1QA
United Kingdom

Tel: 01384 489 250

Fax: 01384 489 707

ambiradsales@nortek.com

www.ambirad.co.uk

