

**AMBI-RAD®**

Energy Efficient Heating Systems



# AR & ARE SERIES HEATER INSTRUCTIONS

**FOR**

**GAS**

**ELECTRIC**

**INSTALLATION**

**COMMISSIONING**

**AND**

**SERVICING**

# AR SERIES HEATER

## GAS, ELECTRIC, COMMISSIONING & SERVICING INSTRUCTIONS.

For heater assembly and installation see coloured instruction sheets for appropriate model. These appliances are for use on natural gas (G20) at a supply pressure of 20 mbar and Propane (G31) at a supply pressure of 37 mbar in G.B. and I.E.

### 1. GAS CONNECTION

The gas connection on the AMBI-RAD heater is R $\frac{1}{2}$  (½ in. B.S.P. external thread).

GAS	NATURAL GAS	PROPANE
Max supply pressure	30mbar	37mbar
Min supply pressure	16.5mbar	N/A

MODEL	GAS	BURNER	SETTING	PRESSURE
	NATURAL GAS			PROPANE**
		G20		G31
AR13GB		MAX 9.7mbar - MIN 6.5mbar		29.4mbar
AR13GBQB		MAX 10.4mbar - MIN 7.0mbar		32.9mbar
AR22GB/QB		MAX 12.5mbar - MIN 8.0mbar		(AR22) 31.6mbar
AR35GB/QB		MAX 11.2mbar - MIN 7.2mbar		(AR35) 34.0mbar
ARE13		8.4mbar		32.9mbar
ARE22		12.5mbar		31.6mbar
ARE35		12.9mbar		34.0mbar

The above data also applies to the SL, H/L, I and HB with or without DA.

**NOTE: \*\*A separate Propane governor must be fitted before each burner.**

**STANDARDS** The Ambi-Rad heater must be installed in accordance with the relevant provisions of the Gas Safety (Installations and Use) Regulations 1984 or the rules in force. Due account should also be taken of any obligations arising from the Health and Safety at Works etc. Act 1974. In addition the installation must be carried out in accordance with the current I.E.E. Regulations, The Building Standards (Scotland) (Consolidation) Regulations, the requirements of BS 5440 1990: Part 1, BS 6891 1988, BS 6896 1991 and any other relevant British Standards and Codes of Practice.

A gas meter is connected to the service pipe by the local Gas Region or local Gas Region contractor. An existing meter should be checked preferably by the Region to ensure that the meter is adequate to deal with the rate of gas supply required. Installation pipes should be fitted in accordance with BS6891:1988, such that the minimum pressure at least as stated above will be achieved and any other British Standards and Codes of Practice. Pipes of a smaller size than the heater inlet gas connection should not be used. The complete installation must be tested for soundness as described in the above standard. It is recommended that installation pipes be blown out by compressed air before being installed or after installation but before heaters are connected.

The gas supply must not be in a position where it is subject to overheating.

A gas union service cock **MUST** be fitted in the gas supply close to the heater, but not onto the burner itself.

It is essential to provide some flexibility in the final gas connection by use of a tested and certified metallic hose to BS6501: Part 1, 1991 (minimum acceptable quality Type 'B' Class 1) or copper expansion loop. When stainless steel flexible hoses are used the hose should be connected in a 180 degree bend without any strain or torsion. See Ambi-rad leaflet Doc. ref: 410.6.90 for details.

**Note:** Take care when making a gas connection to the heater not to apply excessive turning force to the internal controls.

### 2. ELECTRICAL CONNECTION

**WARNING: THIS APPLIANCE MUST BE EARTHED.**

2.1. Supply 230v50 Hz Single Phase.

Current Rating 0.55 amp max (inductive).

Fuse: External 3 amp.

All electrical work should be carried out to I.E.E. standards by a competent electrician.

The electrical connection to the heater is made by means of a three pin plug-in power connector. Live, Neutral and Earth connections should be made via a flexible supply cable to the power connector and routed clear of the heater or tubes. The flexible supply cables should be of 0.5mm<sup>2</sup> complying with BS6500, 1990. Note: SL and DL heaters require an electrical cable between the burner unit and the fan assembly. This to be provided by the installing/electrical contractor.

#### IMPORTANT

The wires in the mains lead are coloured in accordance with the following code:

Green & Yellow - Earth  
Blue - Neutral  
Brown - Live

Instructions for connecting mains lead to plug:

Connect Green and Yellow to plug terminal marked E or Green or Green and Yellow.

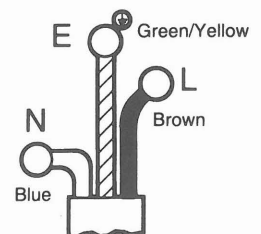

Connect Blue wire to terminal marked N or Black or Blue.  
 Connect Brown wire to terminal marked L or Red or Brown.

It is recommended that the electrical circuit controlling the heater or group of heaters incorporates thermostats, a time switch and if required, manual control switches and a frost thermostat (see fig. 1).

**IMPORTANT**

All such controls and switchgear must be rated to handle the total inductive load of the circuit they control. For inductive load per Ambi-Rad model see 2.1. For large installations, the use of relays or contactors should be considered. The method of connection to the electrical supply must facilitate complete isolation and should be made via a fused double pole isolator having a contact separation of at least 3mm in all poles and supplying the appliance only. Alternatively, connection may be made via a fused three pin plug and unswitched shuttered socket, both complying with the requirements of BS1361 1971(1986). Ensure that a copy of the lighting instructions plate is affixed adjacent to the electricity supply switch. Should this switch serve more than one heater it is only necessary to affix one copy per service switch.

**Fig. 1. Typical External Wiring Diagram** For Individual Flued & Unflued Heaters.

For external wiring diagram for AR/HB Herringbone heater contact AR. Technical Dept.

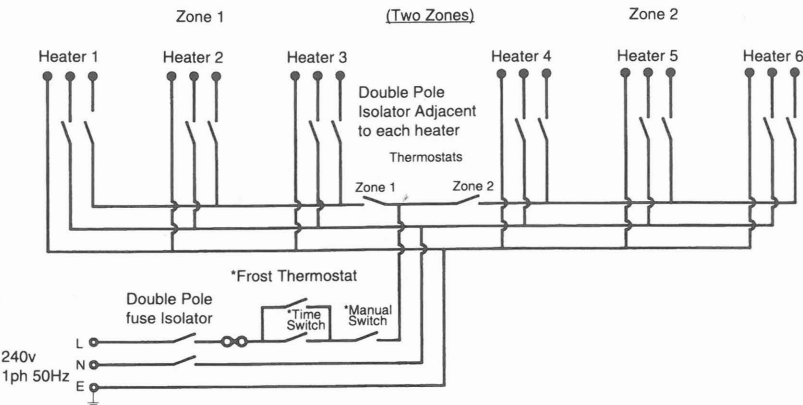

\*Optional  
 Note for more comprehensive control arrangements see  
 Ambi-Rad black bulb and control panel leaflets.

**Fig. 2. Internal Wiring Diagram**

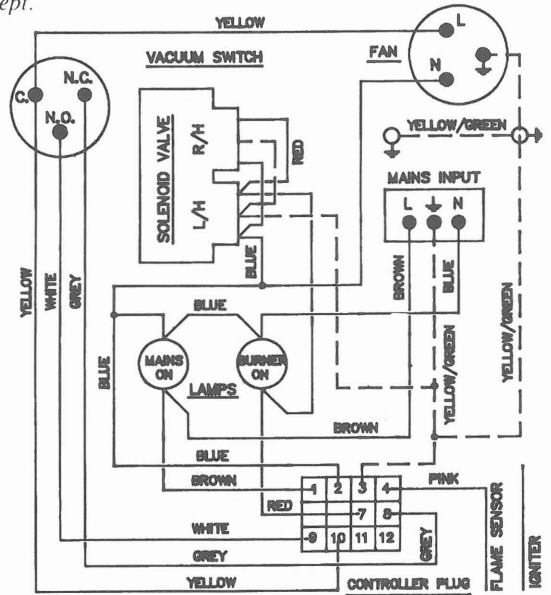

**3. FLUE CONNECTION**

The AMBI-RAD heater may be installed with or without a flue to atmosphere providing the air supply and building ventilation requirements as stated in BS 6896: 1991 are complied with and providing due consideration is given to the possibilities of condensation forming on cold surfaces when used as an unflued heater.

**3.1 UNFLUED INSTALLATION**

Permanent ventilation required is as follows:

Natural Ventilation (to be fitted at high and low level with minimum distance between of 3m).

- Low Level - When air change rate is less than 33 m<sup>3</sup>/hr/kW of total rated input. Either 1.4 cm<sup>2</sup> for each 1 m<sup>3</sup>/h per kW below 33 m<sup>3</sup>/h per kW.
- or 52 cm<sup>2</sup>/kW of total rated input.
- High Level - Above areas where personnel are working. As above.

Mechanical Ventilation

Minimum proven air flow. 33 m<sup>3</sup>/hr/kW of total rated heated input.

For detailed information please refer to AMBI-RAD design manual. If the heater is installed without a flue, ensure that combustion gases do not impinge on combustible materials. The maximum permitted temperature for such materials is 50°C (BS7186) 1989.

**3.2 FLUED INSTALLATION**

The AMBI-RAD heater may be installed with a flue. A down-draught diverter (supplied as an optional extra by the manufacturer) must be fitted to the induced draught fan exit by means of the screws and clamp plates provided. The diverter is designed to accept a 125mm (5in.) nominal bore propriety twin wall metal flue pipe complying with BS715 1993. The joint should be sealed with heat resistant caulking and faced off with fire cement. If single wall metal flue pipe complying with BS715 1993 is used, then an adaptor will be required. A flue pipe should be adequately supported at regular intervals from the building structure and terminated externally with a British Gas Tested and Certified terminal. The maximum flue length is 9m (30ft) and maximum number of bends is two. All connections in the flue pipe must be properly sealed. Permanent ventilation is required as follows.

Natural Ventilation (preferably at low level)

Up to and including 60 kW — 4.5 cm<sup>2</sup>/kW

Over 60 kW — 270 cm<sup>2</sup> + 2.25 cm<sup>2</sup>/kW in excess of 60 kW total rated input.

#### Forced Ventilation

Minimum proven air flow — 2.35 m<sup>3</sup>/h/kW of total rated input.

For detailed information please refer to Section 7 BS 6896, 1991, Installation of Gas Fired Overhead Radiant Heaters for Industrial and Commercial Heating (2nd and 3rd family gases).

### **4. FRESH AIR DUCTED INLET (models AR13 DA, AR22 DA & AR35 DA, ARE13 DA, ARE22 DA, ARE35 DA)**

When the AMBI-RAD heater is to be installed in locations where there is airborne dust or where there is a polluted atmosphere, e.g., chlorinated vapours, process dust etc., a ducted fresh air supply must be provided to the burner. Where a fresh air ducted inlet is to be fitted to the burner assembly the Stainless Steel Air intake grill must be removed from the burner casing and the orifice fitted with a blanking off plate. (ARE35, fitted with 90° bend with 100mm diameter inlet).

**Note:** The pressure sensing tube is to be re-positioned to align with the orifice in the ducted fresh air connection of the combustion chamber cover plate (see drawing No. ER 3473). (ARE35, connection to 90° bend).

These models incorporate a 100mm (4in.) fresh air duct connection. A fresh air duct of minimum diameter 100mm (4in.) should be connected to the combustion chamber cover plate inlet duct. For ARE 35 see above. A flexible joining piece should be used, available from the manufacturer, fixed with hose clips to facilitate disconnection when servicing the burner. The maximum length of fresh air inlet duct is 7m (23ft) of 100mm (4in.) diameter duct. Maximum number of bends is two. A position should be selected for the inlet of the fresh air duct such that will receive dust free clean air. A cowl of the British Gas Tested and Certified type, such as the GCI or GLC terminal, should be fitted at the inlet of the duct. If the duct inlet is located on a roof the underside of the inlet cowl must be at least 600mm (2ft.) above roof level and at least 250mm (10in.) higher than any projection on the roof within a 2 metre radius of the cowl. For fresh air ducted inlet heaters, heater model is suffixed with DA to indicate ducted air inlet (e.g., AR22 DA).

### **5. INSULATED REFLECTOR MODELS**

An insulated reflector can be used to conserve upward radiation from the reflector. In addition, insulation should be used where dust is likely to settle on the reflector to reduce the increased radiation caused by the dirty reflector.

After the reflectors are assembled, the insulation should be attached to the back of the reflector with the spring ties provided. The insulation fits underneath the suspension brackets.

### **6. COMMISSIONING FOR INDIVIDUAL FLUED & UNFLUED HEATERS.**

*For commissioning procedure for Herringbone system and DL heaters see Doc ref: 134/06/92 Section 4.*

Inspect installation and ensure that it has been carried out in accordance with these instructions. Ensure that electrical and gas supplies are isolated.

The gas supply should be purged and tested for soundness in accordance with the British Standard BS6891: 1988, BGIM/16, BGC Report 1M/2 and any other British Standard and Codes of Practice.

Open isolating valve.

Remove the combustion chamber cover plate or ducted air inlet connection by unscrewing 6 fixing screws. Take care not to damage the sealing gasket. Inspect the burner and electrode assemblies, ensuring these are securely fixed and all electrical connections securely made. Replace the cover plate or ducted air inlet connection, ensuring that the sealing gasket is correctly positioned and the six screws are fully tightened. The heater will not operate until this plate is refitted.

Open the control housing cover door by unscrewing the 2 securing screws. Ensure all internal components are securely fixed and all connections securely made.

Switch on the electrical supply to the heater and observe the correct start up sequence as follows:

The mains lamp will illuminate. The vacuum switch checking relay ( inside flame electronic sequence control box) will pull in and the ID fan will start to run. Safe-start checks are carried out automatically and a purge period of approximately 9 seconds will commence.

At the end of the purge period the ignition sequence will commence. The spark ignition will be energised producing a spark at the ignition electrode. The gas shut off valve will at the same time be energised. If ignition is successful the flame is detected by the flame sensing probe and the ignition spark is switched off. The "burner on" (amber) lamp indicates that the gas safety control valves are energised.

If ignition is unsuccessful the gas safety control valve is closed and the spark ignition de-energised after approximately 5 to 7 seconds. After an unsuccessful ignition attempt the electronic sequence controller will "lock-out". The "power lamp" (red) only will remain illuminated and the fan will continue to run. To reset this "lockout" condition, switch off the power supply to the heater, wait 15 seconds then restore it. If repeated lock-out occurs investigate cause.

In the event of an electrical fault after installation of the appliance preliminary electrical systems checks should be carried out (re-earth continuity polarity and resistance to earth).

To shut down the heater, switch off the power supply to the heater. Automatic control of the heater or a series of heaters may be achieved by incorporating thermostats, time switches, frost thermostats, manual over-ride switches etc., in the electrical supply to the heater(s) (see Fig. 1). It is essential to allow a delay of 15 seconds after switching off a heater before attempting to restart.

If at any time after completion of the start up sequences, loss of flame should occur, the electronic sequence controller will attempt to re-ignite. If this is unsuccessful lock-out will occur.

Set burner gas pressure as follows. Isolate gas supply. Unplug mains input connector to heater. Unscrew the 2 fixing screws in the hinged safety control housing lid and swing away. Remove pressure test point screw and connect a 'U' tube manometer to the pressure test nipple located on the body of the gas valves. Remove the slotted cover from the pressure test regulator revealing the adjustable screw. Replace mains input connector and start the heater. Using a suitable screwdriver adjust the pressure regulator, turning the screw clockwise to increase the pressure or anti-clockwise to decrease the pressure. Set the burner pressure to the required figure given in Section 1. Switch off the heater by pulling out the mains input connector. Disconnect 'U' Tube manometer and refit screw in pressure test nipple. Replace cover on pressure regulator. If heater is flued check that there is adequate updraught at the draught diverter e.g., by means of a smoking taper when heater is running.

Check the operation of the flame safeguard equipment as follows: With the heater running normally, switch off the gas supply at the appliance isolating valve. Observe that the "burner on" lamp extinguishes within one second. After a purge period of approximately 9 seconds the heater should attempt to relight and if the gas isolating valves have been left off lock-out should occur indicated by power light only being illuminated and fan running.

Check the operation of the vacuum proving switch as follows: With the heater running normally pull out the three pin fan connection plug, thus causing the fan to slow down and stop. Within 3 seconds the burner should shut off. Observe for at least 20 seconds that there is no attempt to re-ignite, then replace the three pin plug and observe that the heater proceeds to ignite in the normal way.

Close the Safety Control housing lid which is secured with the 2 fixing screws.

Hand the Users Instructions to the user and explain how to operate the heater.

Leave the Installation and Servicing Instructions at the users meter or preferably with the service/maintenance engineer/manager for use on future service calls.

**Note:** It will be noted that heaters have a tendency to bow when hot, this is normal and quite acceptable.

## **7. SERVICING INSTRUCTIONS**

Under normal working conditions it is recommended that the AMBI-RAD heater has a routine service once per year. In exceptionally dirty or dusty conditions, such as may occur in a foundry, more frequent servicing may be desirable. Servicing work should be carried out by a qualified gas servicing engineer.

### **IMPORTANT**

1. Never rest anything, especially ladders, against the heater.
2. Isolate gas and electrical supplies before commencing any servicing work or component exchange.
3. Unless otherwise instructed, re-assemble parts in reverse order to the instructions given below.
4. Always test for gas soundness with a suitable leak detection fluid after completing any service or exchange of gas carrying components.

## **8. ROUTINE SERVICE**

### **8.1 ID Fan**

Remove ID fan by unplugging its electrical connection from the burner/control assembly and slackening the fan securing pinch screw. If a flue is fitted, this must also be disconnected. The fan will now slip off the emitter tube. Inspect the main fan impeller and remove any dust by brushing with a soft brush. Similarly remove any dust from the finger guard covering the secondary (cooling) impeller and the mesh aperture in the motor cover. Ensure that the impeller turns freely and that there is not excessive play in the bearings. Do not replace fan until emitter tube inspection has been completed.

### **8.2 Emitter Tubes Inspection**

Brush away any dust on the exterior of the emitter tubes.

Inspect the emitter tubes internally. If there is any appreciable build up of dust or deposits the tubes should be cleaned internally. Remove the burner/control assembly as directed in 8.4 below.

Detach return bend by releasing the 2 pinch screws and remove the turbulators. The two tubes can then be cleaned by passing rods and a suitable scraper through them or by use of an industrial vacuum cleaner with long extension tube.

### **8.3 Reflector**

Although not considered part of an annual routine service, the condition of the reflector should be noted and the users attention drawn to any cleaning necessary. The reflectors can be simply withdrawn for cleaning by removing the two M6 nuts and bolts securing them and sliding them out of the suspension brackets once the reflector end caps have been removed. The reflectors can be cleaned with a soft cloth and detergent in water. A mild non abrasive metal polish may be used in cases of extreme discolouration. Dirty reflectors will increase the heat radiation upwards into the roof space by 3-4%.

### **8.4 Removal of Burner/Control Assembly**

Remove the burner/control assembly by disconnecting the gas and electrical supply, fresh air inlet ( if fitted ) and the fan electrical connection. Slacken the burner fixing pinch screws and draw the assembly off the emitter tube.

### **8.5 Burner/Electrode Assembly**

Inspect the burner electrode assembly by removing the six dome head screws securing the combustion chamber cover plate on top of the burner box, taking care not to damage the sealing gasket. Remove the burner head by unscrewing it from the injector, taking care not to drop it onto the leads of the ignition electrodes. Pepper pot burner heads should be examined every 6 months for signs of blockage and cleaned by blowing compressed air in reverse direction to flow. Re-new the electrode assembly if it is not in good condition. The assembly is removed by removing two M4 screws which attach it to the floor of the combustion chamber. The assembly is then lifted out of the combustion chamber and the two connection cables disconnected.

If the electrode assembly is in good order check the spark electrode gap. This should be  $3.5 \text{ mm} \pm 0.5 \text{ mm}$ . Adjust the gap if necessary by bending the earth rod. Refit the electrode assembly in the reverse order of removal, ensuring that the electrical connections to the assembly are the correct way round and secure.

Inspect the injector and clean as necessary. Do not broach out. To remove or replace the injector with the burner head removed, unscrew the injector from its carrier using a spanner on the hexagon portion of its body. When replacing the injector ensure that it is fully tightened in its carrier. Replace the burner head. Replace the combustion chamber plate cover, renewing the sealing gasket Part No. 3190, if this is not in good condition.

Inspect the burner fresh air inlet duct and flue if fitted and ensure that they are free of any blockage or obstruction. Inspect the air inlet terminal and ensure this is not liable to obstruction. Replace the burner/control and fan assemblies engaging them fully on their tubes and secure by tightening the pinch screws ensuring that both items are squarely and neatly positioned. The burner should be positioned horizontally and the fan discharge should face vertically upwards for flued heaters, or horizontally away from the burner

for unflued heaters as detailed in fig.2 and fig.3 of the heater assembly instruction sheets, Doc ref: 75/09/91 and 76/09/91. Re-commission the heater by following the procedure for commissioning as per section 6, taking care to check that the burner gas pressure is correctly set to that indicated on the data badge and that the vacuum switch and flame safeguard equipment function correctly.

## 8.6 Auxiliary Controls

Check that auxiliary controls such as room thermostats, switches, frost thermostats. etc., function correctly and are set to operate at the desired temperatures. Ensure that the User is aware of the functions of the auxiliary control and their correct settings. For the most efficient operation of the heating system the time switch, if fitted, should be set to switch on normally between 1/4 hour and 1 hour before commencement of the occupation of the building, depending on local conditions. The correct setting of the room thermostat can only be determined by experience in cold weather, when it should be set to shut off the heaters when a comfortable level of warmth has been achieved. This setting will normally be several degrees below that which would be required with a convective heating system.

## 9. REPLACEMENT OF COMPONENTS

**WARNING:** Isolate gas and electrical supplies before carrying out any repair work. Always test for gas soundness with a suitable leak detection fluid.

Fig. 3. Model AR Burner Assembly

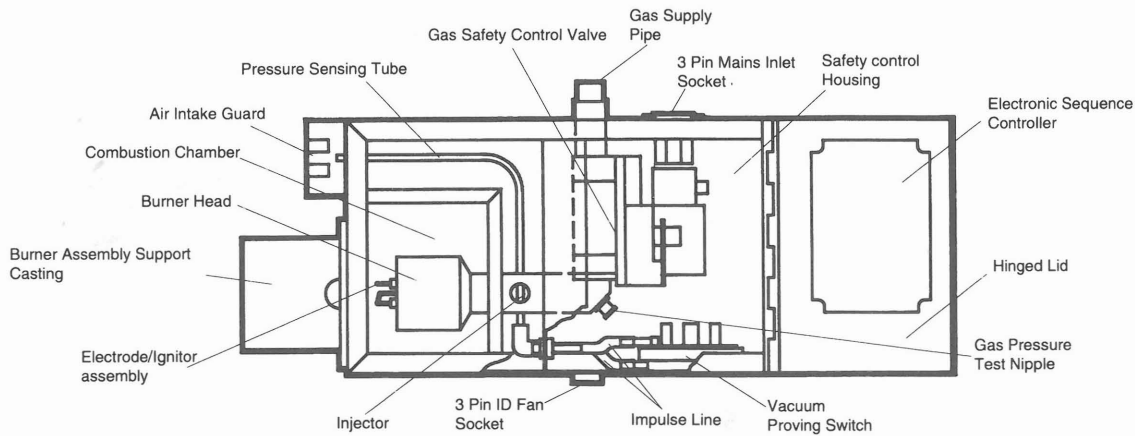

Note: Combustion Cover Plate not Shown.

### 9.1 To Replace ID Fan

Remove ID fan connecting plug from the burner control assembly. Disconnect flue if fitted. Slacken pinch screw securing fan to emitter tube. Draw fan off tube. Remove three M5 screws securing fan support to fan casing. Refit support flange to new fan with the pinch bolt facing in the same direction as the fan outlet. Refit the fan to the heater, ensuring that the fan discharge faces upwards for flued heaters or horizontally away from the burner for unflued heaters. See Fig 2 and Fig 3 of heater assembly instructions sheets. Doc ref: 75/09/91 and 76/09/91.

### 9.2 To Replace Any Components In The Burner/Control Assembly

This assembly should be removed from the heater by first disconnecting the gas and electrical supplies and the fan electrical connection. Slacken the securing pinch screw and draw the burner/control assembly off the emitter tube. When refitting the burner assembly to the heater ensure the box is horizontal - i.e. with indicator lamps facing the floor.

### 9.3 To Replace Electrode Assembly

Remove top cover of combustion chamber by removing the six dome headed fixing screws, taking care not to damage the gasket. Remove the M4 screws securing the electrode assembly and pull off the two electrode cable connectors. Re-connect the cable connectors to the new electrode assembly (the two connectors are non interchangeable) and refit the electrode assembly (see 8.5). Refit the combustion chamber cover plate and sealing gasket. Replace the sealing gasket if this is damaged.

## 9.4 To Replace The Burner Head

Remove combustion chamber cover as in paragraph 9.3. Unscrew burner head from the injector, taking care not to drop it onto the ignition leads. Refit new burner head and repalce combustion chamber cover plate replacing the gasket if this is damaged.

## 9.5 To Replace The Injector

Remove burner heads as in 9.4. Unscrew injector from its carrier using a spanner on the hexagonal portion of its body. When replacing ensure the injector is fully tightened in its carrier. For correct injector size see coloured assembly instruction sheet technical data for appropriate heater model. Doc ref: 75/09/91 or 76/09/91.

## 9.6 To Replace Gas Safety Control Valve (double solenoid and governor models Honeywell and Black/Teknigas)

Remove combustion chamber cover as in paragraph 9.3. Remove control housing cover by removing the two dome headed fixing screws. Remove burner head as in 9.4. Remove 2 screws holding inlet gas connection supply support plate and remove. Disconnect the gas valve electrical connection, marking each connection. The gas valve and injector can now be removed as an assembly. Using an approved pipe joining compound on pipe threads, refit the pipe fittings onto the replacement control valve. Replace the control valve into the control housing. N.B. Refit burner onto injector holder before tightening inlet support plate screws. Carry out commissioning (section 6), setting the burner pressure to that indicated on the data badge. **Note:** Insulated inline connectors are used on Black/Teknigas control valve.

## 9.7 To Replace The Electronic Sequence Controller

Swing open the safety control housing cover by unscrewing 2 screws. Disconnect the electrical connector on the side of the electronic sequence controller. Unplug the single grey high tension lead from the electronic sequence controller. Remove the two bolts securing the sequence controller to the control housing door and replace the sequence controller using the high tension lead (grey) from the old controller unless its insulation is damaged. When refitting the Pactrol sequence controller, take care that the rear flanges of the sequence controller are correctly located underneath the retaining lip in the door of the control housing (Pactrol P16DIA only). Refit the two bolts and electrical connector into the sequence controller and high tension leads into its connector.

## 9.8 To Replace The Vacuum Proving Switch

Disconnect the 2 silicon rubber tube connections at the vacuum switch. Disconnect the three push on connectors from the vacuum switch. Remove the two screws securing the vacuum switch and slip the vacuum switch out of the control housing. Refitting is a reversal of the above, taking care to correctly re-connect the three cables (see fig. 4 below).

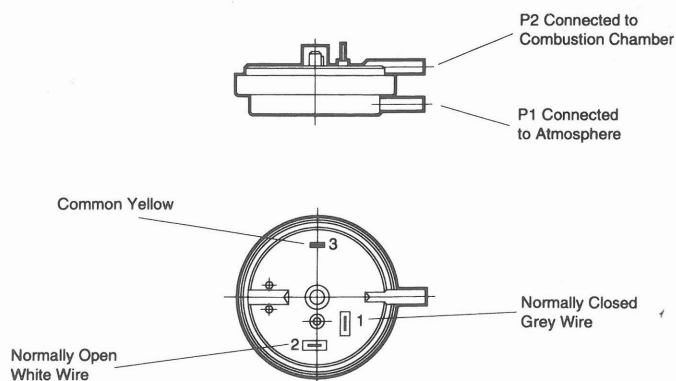

Fig. 4. Beck Vacuum Proving Switch

# TROUBLE SHOOTING CHECKLIST

## Symptoms

### 1 BURNER WILL NOT START

1.1 Red "Mains On" light does not illuminate.

## Possible Causes

- External controls, thermostats, time switch etc., not calling for heat
- Fuse blown
- Fan connector plug not fully engaged
- Loose electrical connection.
- Fan seized or faulty motor
- Sequence Controller relay failing to pull in and/or hold in.
- Vacuum switch not returning to normal (switched off) position.
- Fan tripped out on overload

## Remedy

- Adjust controls
- Check for short circuit in wiring or individual electrical components.
- Engage securely
- Check all connections
- Replace fan, re-commission heater, especially checking gas pressure settings
- Check 1.2e below if satisfactory, replace sequence controller.
- Replace vacuum switch
- Check overload setting: Single phase 3.8 amp, 3 phase 0.8 amp. Reset button on contactor in control panel. Check for build up of condensate in fan casing.*

1.2 Red light illuminates

*HB Herringbone system only*

1.3 Fan starts but burner does not attempt ignition.

- Insufficient vacuum generated by fan
- Blocked emitter tube
- Combustion chamber cover permitting air leakage.
- Vacuum impulse line between combustion chamber and vacuum switch insecure or defective.
- Vacuum switch "pulls in" but electronic sequence controller does not proceed to programme ignition sequence.

- Clean fan blades with soft bristle brush
- Clean emitter tube internally
- Examine condition of sealing gasket, tighten down lid securely.
- Fix securely in place.

*HB Herringbone system only*

1.4 Burner proceeds to ignition stage (normally indicated by audible spark gas valve energised and "burner on" light illuminated) but burner does not light.

*g. Leaks in joint separation in manifold system*

- No spark.
- Gas safety valve faulty or defective
- Insufficient gas pressure
- Burner injector blocked

- Replace burner sequence controller unit but first check that the cause of failure is not a short on output circuit, by measuring resistance between pins 2 and 7 of burner control unit plug. A reading of 10,000 OHMS indicates short circuit on gas valve burner indicator light or associated wiring.
- Reseal or reconnect*
- Check electrode for cracks - replace if necessary. Check high tension connections are secure. Check spark gap is 3.5+/- 0.5mm. If no high tension output from electronic controller, replace controller.

- Replace solenoid operator section of gas valve.
- Set burner pressure to that indicated on the data badge (see commissioning).
- Clean burner injector

2 BURNER LIGHTS BUT SHUTS DOWN AFTER A FEW SECONDS.

- Inadequate flame signal. This can be verified by connecting a sensitive microammeter in series with the violet wire which passes through the combustion chamber bulkhead. The correct reading should be 5uA+/- 1uA.
- Flame unstable.
- Inadequate gas supply. Observe burner gas pressure with all heaters operating.
- Insufficient vacuum at combustion chamber, causing vacuum switch to cut off.

- Replace flame electrode. Check connections to electrodes and terminal 4 of electronic sequence controller plug. Replace the electronic sequence controller.
- Check cleanliness of burner and set burner pressure as per section 8
- If gas pressure drops below that indicated on the data badge, examine gas supply pipework for excessive pressure loss.
- Clean fan blades with soft bristle brush. Inspect tube internally and clean if necessary (see servicing instructions).

3 HEATER SHUTS DOWN AFTER OPERATING FOR A PERIOD OF TIME

Refer to 2a and 2d

- If problem persists, replace vacuum switch.

## SPARES REFERENCE LIST

MODEL	AR22	AR35	AR35
Description	Part No.	Part No.	Part No.
Emitter tube per length mild steel	1030	N/A	1040
Emitter tube per length stainless steel (Optional)	N/A	N/A	1050
Emitter tube per length stainless/mild steel	N/A	N/A	1050-SUB
Emitter tube per length aluminised steel	N/A	1120	N/A
Reflector	1255	1260	1265
ID Fan Assembly	FAR13 UK	FAR22 UK	FAR35 UK
ID Fan	2506	2506	2506
Beck Vacuum Proving Switch	2190	2190	2190
P16DI Electronic Sequence Controller	2010	2010	2010
P16DIA Electronic Sequence with JST Connector	2015	2015	2015
Black Teknigas Twin Gas Safety Control Valve - Nat Gas	2032	2032	N/A
Honeywell Twin Gas Safety Control Valve - Nat gas	2046	2046	3187
Honeywell Twin Gas Safety Control Valve - Propane	3186	3186	3186
S.I.T. Twin Gas Safety Control Valve Nat Gas/Propane	2052	2052	2052
Mains Input Connector Cable	2125	2125	2125
Red and Amber Lamp 240/220V	3167	3167	3167
Electrical Harness	2243	2243	2243
Burner Assembly - Nat Gas	BAR13NUK	BAR22NUK	BAR35NUK
Burner Assembly - Propane	BAR 13PUK	BAR22PUK	BAR35PUK
Electrode Ignition/Assembly	3175	3175	3175
Standard Burner Head (AR/ARE)	3005	3035	3035
Pepper Pot Burner Head (AR only)	3169-SUB	3170-SUB	3070.1-SUB
Burner Injector (Natural Gas)	2277	2290	2291
Burner Injector (Pepper Pot Head) (Natural Gas)	2287	2290	2291
Burner Injector Carrier	2265	2265	2265
Burner Support Casting	3004	3034	3084
Cross Current Deflector	2382-SUB	2837-SUB	2842-SUB
Burner Gasket	3190	3190	3190
Impulse Line Assembly	2267-SUB	2267-SUB	2267-SUB
Centre Bracket	N/A	6575	N/A
U Bend	3008	3036	3099-SUB
Type 'A' Bracket with Tabs	6570	N/A	6579
Type 'B' Bracket	6571	6576	6580

NOTES

## USER INSTRUCTIONS FOR AMBI-RAD AR & ARE SERIES OF HEATERS.

AMBI-RAD is an overhead radiant heating system for industrial and commercial buildings. The AMBI-RAD heater is suspended horizontally overhead from the roof or inclined mounted at 35° to 55° from the horizontal and heats by radiation in the same way as the sun.

### IMPORTANT

1. This appliance must only be installed by a competent person in accordance with the requirements of the Gas Safety (Installations & Use) Regulations 1984 and the Health and Safety at Work etc. Act 1974 or the rules in force.
2. WARNING: THIS APPLIANCE MUST BE EARTHED.
3. Never rest anything, especially ladders, against the heater.

To start the AMBI-RAD heater:

1. First ensure that the gas supply to the heater is turned on.
2. Ensure that the settings of any time-switch and thermostat are such that the heating system will be required to operate.
3. Switch on electrical supply to heater. Mains light, coloured red, will illuminate and ignition sequence will commence.
4. After completion of an air purge period, ignition of the burner will occur and burner light, amber, will illuminate.
5. If ignition attempt fails, burner sequence controller will lock out with mains light only illuminated.
6. If lock out occurs switch off electrical supply, wait 15 seconds then switch on again. If lock out occurs again switch off heater and call service engineer.

N.B. Heater will have tendency to bow when hot, but this is quite acceptable.

To switch off AMBI-RAD heater.

Switch off electrical supply to the heater. The burner will shut off and the fan will stop.

If the heater is switched off for periods in excess of one week it is highly recommended that both gas and electrical supplies are turned off.

Servicing:

To ensure continued efficient and safe operation it is recommended that the heater is serviced regularly by a competent person, e.g., every year in normal working conditions but in exceptionally dusty or polluted conditions more frequent servicing may be required. The manufacturer, whose address is given below, offers a maintenance service. Details available on request.

Because of our policy of continuous development Ambi-Rad limited reserves the right to vary the equipment specification without notice.

# AMBI-RAD

Energy Efficient Heating Systems

P.O. Box 30,  
Mucklow Hill, Halesowen, West Midlands.  
B62 8DS  
Tel: 0121 503 0707. Fax: 0121 501 2955