

INSTALLATION AND OPERATING MANUAL

ACR Recessed Air Curtain

Electrically Heated, Ambient & LPHW

WARNINGS

Nortek Global HVAC (UK) Limited equipment must be installed and maintained in accordance with the requirements of the Codes of Practice or rules in force. All external wiring MUST comply with the codes of practice or rules in force in the country of installation.

Improper installation, adjustment, alteration, service or maintenance can cause property damage, injury or death. Read instructions before installing or servicing this equipment. Gas-fired appliances are not designed for use in hazardous atmospheres containing flammable vapours or combustible dust, containing chlorinated or halogenated hydrocarbons, or in applications with airborne silicone substances.

Reznor® is a registered trademark of Nortek Global HVAC, LLC.

Introduction.

Welcome to the range of Airbloc ACR Recessed Air Curtains. Local regulations may vary in the country of use and it is the installers responsibility to ensure that such regulations are satisfied

All installation and assembly procedures must be carried out by suitable competent persons. Commissioning and service procedures must be carried out by suitable qualified persons to the statutory regulations in the country of use.

When installing, commissioning and servicing is undertaken on these air curtains due care and attention is required to ensure that working at height regulations are adhered to, at the mounting heights specified.

All Dimensions shown are in mm unless otherwise stated.



PLEASE READ this document prior to installation and use. The safety of this heater is guaranteed only by the correct usage in accordance with these instructions, therefore it is recommended that they are retained for future reference.

The manufacturer reserves the right to alter specifications without prior notice.

Any reference made to Laws, Standards, Directives, Codes of Practice or other recommendations governing the application and installation of heating appliances and which may be referred to in Brochures, Specifications, Quotations, and Installation, Operation and Maintenance manuals is done so for information and guidance purposes only and should only be considered valid at the time of the publication. Benson Heating cannot be held responsible from any matters arising from the revision to or introduction of new Laws, Standards, Directives, Codes of Practice or other recommendations.

IMPORTANT NOTICE TO INSTALLERS

Installers should satisfy themselves that the gas pipework installation is carried out in accordance with all current legislation, Codes of Practice and recommendations .

Additionally it may be necessary to protect the gas valves which form part of the heater or burner assembly from potential pipe contamination particularly, but not exclusively, where copper gas pipework is used.

In instances where copper pipework is to be used for all or part of a gas pipework installation, including short length final connections then we advise that installers consult with gas supplier or provider and satisfy themselves what additional precautions may be necessary.

Document Index.

- 1 Installation Requirements
 - 1.1 Compliance Notice
 - 1.2 Certificate of Conformity
 - 1.3 General Product Information
 - 1.4 Model Definition
 - 1.5 General Requirements
 - 1.6 Health and Safety
 - 1.7 Delivery and pre-installation
 - 1.8 Location
 - 1.9 Clearance Distance
 - 1.10 Electrical Supply
 - 1.10.1 Electronic Controller
 - 1.10.2 SmartElec3 Controller
- 2 Dimensions
 - 2.1 ACR Air Curtain
 - 2.2 Program keypad
 - 2.3 Optional SmartElec3 Controller
- 3 Technical Specifications
 - 3.1 Electrical Heated, Std Capacity 6&9kW 1P
 - 3.2 Electrical Heated, Std Capacity 9,12&18kW
 - 3.3 Electrical Heated, High Capacity 12-18kW
 - 3.4 Ambient, Std Capacity
 - 3.5 Ambient, High Capacity
 - 3.6 LPHW, Std Capacity
 - 3.7 LPHW, High Capacity
 - 3.8 Electronic Controller
 - 3.9 SmartElec3 Controller
 - 3.10 LPHW/Ambient Controller
- 4 Wiring Diagrams
 - 4.1 Installer Wiring Electrically Heated 6&9kW 1P
 - 4.2 Installer Wiring Electrically Heated 9,12&18kW 3P
 - 4.3 Installer Wiring Ambient
 - 4.4 Installer Wiring LPHW
 - 4.5 Factory Wiring Electrically Htd 1000/1500 6kW 1P
 - 4.6 Factory Wiring Electrically Htd 2000 9kW 1P
 - 4.7 Factory Wiring Electrically Htd 1000/1500 9&12kW 3P
 - 4.8 Factory Wiring Electrically Htd 1200/1800/2000 12&18 kW 3P
 - 4.9 Factory Wiring Ambient ACR1000/1500 1P
 - 4.10 Factory Wiring Ambient ACR2000/1200/1800 1P
 - 4.11 Factory Wiring LPHW ACR1000/1500 1P
 - 4.12 Factory Wiring LPHW ACR2000/1200/1800 1P
 - 4.13 Network Wiring Ambient/LPHW
 - 4.14 Network Wiring Electrically Htd
 - 4.15 Installer Wiring SmartElec3
 - 4.16 Factory Wiring ACR1000/1500 SmartElec3 Controller
 - 4.17 Factory Wiring ACR1200/1800/2000 SmartElec3 Controller
 - 4.18 Network Wiring SmartElec3
- 5 Installation Requirements
 - 5.1 Mounting
 - 5.2 Electrical Supply
 - 5.3 Installation
 - 5.4 Program Keypad
 - 5.5 Option SmartElec3 Controller
 - 5.6 LPHW only
 - 5.6.1 3 Port Valve
 - 5.7 Installation Wiring
- 6 Servicing & Maintenance Instructions
- 7 Spare Parts
 - 7.1 General
 - 7.2 Standard Controller
 - 7.3 SmartElec3 Controller
 - 7.4 Heating mediums
- 8 Fault Finding Guide
 - 8.1 General
 - 8.2 Electrical Heated
 - 8.3 Standard Controller
 - 8.4 Optional SmartElec3Controller
 - 8.4.1 Fault Code chart
 - 8.4.2 LED indication
- 9 Replacing Parts
 - 9.1 Electrical Element SE
 - 9.2 Electrical Element HE
 - 9.3 Rotor/Motor SE
 - 9.4 Rotor/Motor HE
 - 9.5 LPHW Coil
- 10 User and Operating Instructions
 - 10.1 Standard Keypad
 - 10.1.1 Keypad Buttons
 - 10.1.2 Operation
 - 10.1.3 Standard Settings
 - 10.1.4 Engineers Settings
 - 10.1.4.1 Door Link Settings
 - 10.1.4.2 Link-Group Interlock
 - 10.1.4.3 All Controllers
 - 10.2 LPHW/Ambient Controller
 - 10.2.1 Keypad Buttons
 - 10.2.2 Operation
 - 10.2.3 Standard Settings
 - 10.2.4 Engineers Settings
 - 10.2.4.1 Door Link Settings
 - 10.2.4.2 Link-Group Interlock
 - 10.2.4.3 All Controllers
 - 10.2.4.4 External Temperature
 - 10.2.4.5 External Temperature Offset
 - 10.2.4.6 Temperature Limits
 - 10.2.4.7 Air Return & Pipe Cold Sensors
 - 10.3 Optional SmartElec3 Controller
 - 10.3.1 Keypad Buttons
 - 10.3.2 Operation
 - 10.2.2.1 Normal Mode Display
 - 10.3.3 Off Mode
 - 10.3.4 Settings Mode
 - 10.3.4.1 Activate Settings Display
 - 10.3.4.2 Settings Display
 - 10.3.5 Set Up Configuration
 - 10.3.5.1 Set Fan Speed
 - 10.3.5.2 Set Heat
 - 10.3.5.3 Set Temperature
 - 10.3.5.4 Networked Air Curtains
 - 10.3.6 Engineers Settings
 - 10.3.6.1 Door Link Settings
 - 10.3.6.2 Link-group Interlock
 - 10.3.6.3 All Air Curtains
 - 10.3.6.4 External Temperature

Document Index cont.

- 10.3.6.5 External Temperature Offset
- 10.3.6.6 Temperature Limits
- 10.3.7 Power-up Manual Reset
- 10.3.8 Air Curtain Addressing
- 10.3.9 Keypad Sequences (standard controller)
- 10.3.10 Keypad Sequences (SmartElec controller)

1. Installation Requirements.

 Isolate any electrical supply to the heater and controller before proceeding.

1.1 Compliance notices

The Airbloc ACR Recessed Air Curtain detailed herewith are manufactured by Nortek Global HVAC (UK) Ltd. within a strictly controlled quality environment within the parameters of ISO 9001.

These instructions are only valid if the following country code is on the appliance GB. IE. If this code is not present on the appliance, it is necessary to refer to the technical instructions which will provide the necessary information concerning the modification of then appliance to the conditions of use for the country.

The Airbloc range has been tested and assessed for compliance with the following European Directives.

Machinery Directive:	(2006/42/EC)
Low Voltage Directive:	(2006/95/EC)
Electromagnetic Compatibility Directive:	(2014/30/EU)
Product Liability Directive:	(85/374/EEC)

The manufacturer has taken reasonable and practical steps to ensure that Airbloc ACR Air Curtains are safe and without risk when properly used. These air curtains should only be used in the manner and purpose for which they were intended, and in accordance with the recommendations detailed herewith.

The ACR Air Curtains have been designed, manufactured, assembled, inspected, and tested, with safety and quality in mind, there are certain basic precautions which the installer and user should be aware of, and they are strongly advised to read the appropriate sections of the information pack accompanying the heater, prior to installation or use.

Nortek Global HVAC (UK) Ltd. supports all new products being supplied to their customers with a comprehensive information pack; this clearly defines mandatory instructions for the safe installation, use, and maintenance, of the appliance(s).

Where proprietary items are incorporated into Airbloc products, detailed information and instructions are also provided as part of the information pack.

It is the responsibility of the installer, owner, user, or hirer, of such products supplied by Nortek Global HVAC (UK) Ltd., to ensure that they are familiar with the appropriate information/ manuals, supplied by the manufacturer, and that they are suitably aware of the purpose of the manuals and the safety instructions. In addition, operators must be suitably trained in

the use of the appliance so as to ensure its continued safe and efficient use.

Nortek Global HVAC (UK) Ltd. have a commitment to continuous improvement and therefore reserves the right to amend or change the specification of the Airbloc ACR Recessed Air Curtain range subject to compliance with the appropriate European, national, and local regulations.

Contained within the text of the manual, the words 'Caution' and 'Warning' are used to highlight certain points.



Caution is used when failure to follow or implement the instruction(s) can lead to premature failure or damage to the heater or its component parts.



Warning is used when failure to heed or implement the instruction(s) can lead to not only component damage, but also to a hazardous situation being created where there is a risk of personal injury.

The Airbloc ACR Recessed Air Curtain range conform to the following harmonised standards:

BS EN ISO 12100:2010

Safety of machinery. General principles for design. Risk assessment and risk reduction

Safety of Machinery - Basic Concepts, General Principles for Design Technical Principles and Specifications

BS EN 60204-1:2006+A1:2009

Safety of machinery. Electrical equipment of machines. General requirements

BS EN 55014-1:2017

Electromagnetic compatibility. Requirements for household appliances, electric tools and similar apparatus. Emission

BS EN 60335-2-102:2006+A2:2016

Household and similar electrical appliances. Safety. Particular requirements for gas, oil and solid-fuel burning appliances having electrical connections

BS EN 60335-2-30:2009+A11:2012

Household and similar electrical appliances. Safety. Particular requirements for room heaters

and to the following European CE directives-

2006/95/EC - low voltage;

2014/30/EU - electromagnetic compatibility.

1.2 Certificates of conformity

Certificates are available from the Quality Control Department at Nortek Global HVAC (UK) Ltd.

1.3 General product information

Models range from 1000mm to 2000mm in length, in both Standard and High capacity and are available in either Electrically heated, Ambient or LPHW. They are designed for discreet positioning in a suspended ceiling or bulkhead in the doorways of retail or commercial premises. Optional case for doorways with restricted space and no suspended ceiling/bulkhead are available.

Each air curtain is supplied with a fully electronic controller giving multi fan and heat settings (electrically operated units) via a simple key pad which can be mounted up to 100m from the air curtain.

Optional BMS time control, external, thermostats and door interlocks can be installed.



The programmer shown above allows the user to control either a single air curtain, or a network of up to 16 air curtains with the same settings, and provides the following functions:-

- Heat On Off or Auto via optional thermostat
- Off or Low, Medium and High Fan Speeds

For further details please refer to section 10.1

Alternatively on electrically heated models, the optional SmartElec3 control system consists of a base unit (installed within the air curtain) and a program panel that can be installed remote from the air curtain.

Usually, the program panel is mounted at a low level from the air curtain for user access and to a maximum distance of 100m.

The base unit and program panel are linked by a pre-wired low voltage cable as specified in these instructions.

The SmartElec3 factory fitted base unit provides terminals for 3 phase supply connection and sockets the low voltage program panel cable. The SmartElec3 base unit rapidly pulses

energy to the heating elements. This combined with the in-built intelligent sensor control, maintains a fixed outlet temperature, thereby reducing energy consumption as compared to an air curtain without the SmartElec3 control.



The programmer shown above is the same as used on standard air curtains and allows the user to control either a single air curtain, or a network of up to 16 air curtains, each with different settings if required, and provides the following functions:-

- Heat On or Off
- Off or Low, Medium and High Fan Speeds
- Air Outlet Temperature.

For further details please refer to section 10.2



Note

Neither asbestos nor soft soldered joints are used in the construction or manufacture of the Airbloc ACR Recessed Air Curtain range. The materials selected for use can withstand the mechanical, chemical, and thermal stresses which they will be subject to during foreseen normal use when installed in accordance with the manufacturers recommendations.

1.4 Model Definitions

ACR1000xxxx = ACR Airbloc 1M in length. 1200=1.2M; 1500=1.5M; 1800=1.8M; 2000=2.0M.

ACRxxxSxxx = ACR Airbloc Standard Capacity (up to 3M from floor); H=High Capacity(up to 4m from floor)

ACRxxxxExx = ACR Airbloc Electrically heated. A=Ambient; W=LPHW coils.

ACRxxxx12 = ACR Airbloc 12kW coils. 6=6kW; 9=9kW; 12=12kW; 18kW.

-1ph suffix = ACR Airbloc 230V Single phase supply (Std format =3pha)

-SM suffix = ACR Airbloc SmartElec Energy Saving Controller (Std format=Standard AC/ACR Control)

e.g. ACR2000HE18-SM = ACR Airbloc Air Curtain, 2M long, 18kW electrically heated high capacity c/w SmartElec Control.

1.5 General requirements

Caution

Before installation, check that the local distribution conditions, nature of gas and pressure, and the current state adjustment of the appliance are compatible.

Installation and assembly procedures must be carried out by suitable competent persons. Commissioning and service procedures must be carried out by suitable qualified persons.

Warning

Unauthorised modifications to the appliance, or departure from the manufacturers guidance on intended use, or, installation contrary to the manufacturers recommendations may constitute a hazard.

Note

To ignore the warning and caution notices, and to ignore the advice from the manufacturer on installation, commissioning, servicing, or use, will jeopardise any applicable warranty, moreover, such a situation could also compromise the safe and efficient running of the appliance itself, and thereby constitute a hazard.

The installation of the appliance must meet all the relevant European, national, and local criteria.

Prior to installation the following points should be considered;

- The position and mounting height of the Air Curtain for the optimum efficient distribution.
- The position of the Air Curtain relative to the electrical services, and any controllers.
- The position of the Air Curtain relative to the low pressure hot water pipework where appropriate.
- The position of the heater relative to service and maintenance requirements.

Caution

The air Curtain must not be installed within an area where the conditions are unsuitable, e.g. where the atmosphere is highly corrosive, has a high degree of salinity, or where high wind velocities may affect operation. Suitable protection should be provided for the appliance when it is located in a position where it may be susceptible to external mechanical damage.

1.6 Health and Safety

Warning

Airbloc Air Curtains must be installed in accordance with any relevant and Regulations. Due account should be taken of any obligations arising from the Health and Safety at Works Act 1974 or relevant codes of practice. In addition the installation must be carried out in accordance with the current IEE wiring regulations and any other relevant British Standards and Codes of Practice by a qualified installer. Isolate all electrical supplies to the heater & controller before proceeding.

Caution

For your own safety we recommend the use of safety boots and leather faced gloves when handling sharp or heavy items. The use of protective eye wear is also recommended.

Sole liability rests with the installer to ensure that all site safety procedures are adhered to during installation.

Sole liability rests with the installer to ensure that protective safety wear such as hand, eye, ear and head protection is used during installation of the product.

Do not rest anything especially ladders against the product.

1.7 Delivery and pre-installation checks.

On receipt of the Air Curtain, the following checks should be carried out;

- The model is as per order.
- That it is undamaged.
- That it is suitable for the source gas supply.
- That it is suitable for the electrical supply

If any of these points are not satisfied then contact should be made with the Sales Office at Nortek Global HVAC (UK) Ltd as soon as possible by telephoning 01384 489700. In the case of claims for damage, this must be signed for as damaged and reported in writing within 24 hours of delivery, in order to comply with insurance criteria.

1.8 Location

WARNING:

THIS AIR CURTAIN SHOULD NOT BE INSTALLED WHERE THERE IS A CORROSIVE ATMOSPHERE.

Airbloc units should be installed horizontally directly over the door opening. It is recommended that the air curtain is installed on the inside of the building, within the open room space within the ceiling void or roof space.

Care must be taken to allow complete free air movement into the inlet grilles of the unit to ensure correct working operation of the air curtain. The discharge opening should be as close to the top of the door as possible and to cover the entire door width.

Units can be mounted adjacent to each other to cover the full door opening across wider entrances.

1.9 Clearance distances

It is recommended that a minimum clearance of 100mm is allowed around the case. The clearance allows for cable entry and prevents combustible surfaces overheating.

The minimum mounting height (floor to grille) is 1.8m. The recommended maximum mounting height is 3m for standard and 4m for high capacity models.

1.10 Electrical Supply

For full electrical loadings, please refer to the individual technical data sheets within this manual.

It is recommended that the electrical supply to the base unit in the air curtain is via an appropriate switched isolator in accordance with the regulations in force in the country of use and must be via a fused isolator having a contact separation of greater than 3mm in all poles.

BMS control, time switches, room thermostats and door interlocks can be installed at the discretion and responsibility of the installer.

All units must be wired in accordance with I.E.E regulations for the Electrical Equipment of Buildings and the installer should ensure that a suitable isolating switch is connected in the mains supply.



Warning

For safety reasons a good earth connection must ALWAYS be made to the heater and control box.

1.10.1 Electronic controller

Electrically heated supply is either 230V 1 phase (6 and 9kW options) or 415V 3 phase (9 to 18kW), Neutral and Earth. Max cable inlet size is 4mm² or 10mm² (refer to individual technical specification)

Ambient and LPHW supply is 230V 1 phase, Neutral and Earth. Max cable inlet size is 4mm².

Remote unit is wired to the base unit via a pre-wired cable fitted with RJ45 plugs.

1.10.2 SmartElec3 controller

Electrically heated supply is 415V 3 phase, neutral and earth. Max cable inlet size is 10mm².

Keypad is wired to the base unit via a RJ45 pre-wired cable.

Networked air curtain interconnects via a RJ45 pre-wired cable.

2. Dimensions.

2.1 ACR Air Curtain Fig.1

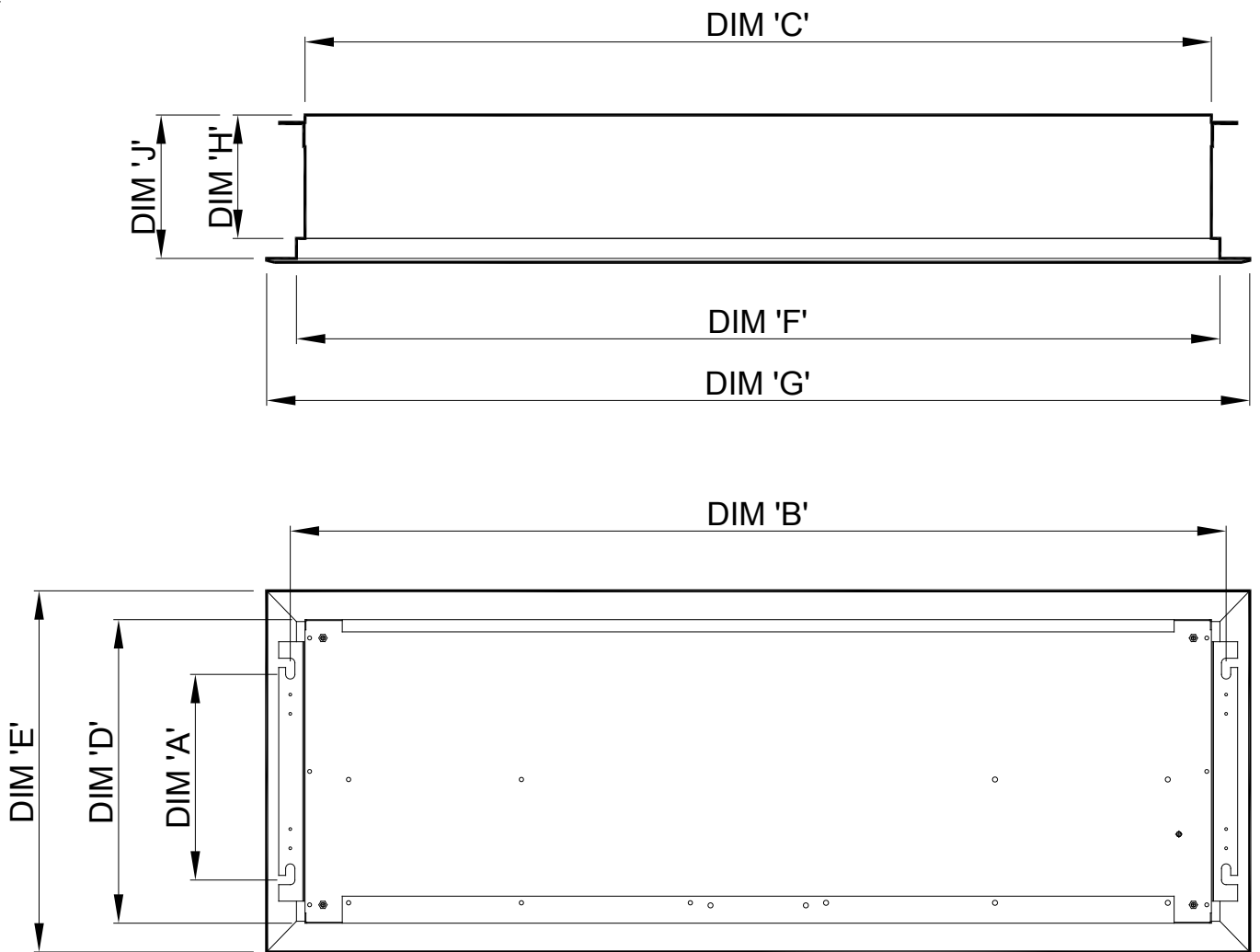

Size	ACR1000SE6/9; ACR1000SW9; ACR1000SA	ACR1500SE12; ACR1500SW12; ACR1500SA	ACR2000SE18; ACR2000SW18; ACR2000SA	ACR1200HE12; ACR1200HW12; ACR1200HA	ACR1800HE18; ACR1800HW18; ACR1800HA	ACR2000HE18; ACR2000HW18; ACR2000HA
A		253			407	
B	1220	1520	2020	1185	1785	2097
C	1182	1482	1982	1150	1750	2059
D		395			550	
E		454			608	
F	1205	1505	2005	1150	1750	2082
G	1242	1542	2095	1210	1810	2140
H		160			180	
J		200			220	

2.2 Program keypad dimensions

The keypad is supplied with an industry standard plastic double surface mounted socket box. Alternatively the keypad can be flush mounted using a customer supplied metal flush box as shown below.

Fig.2. Using surface mount box

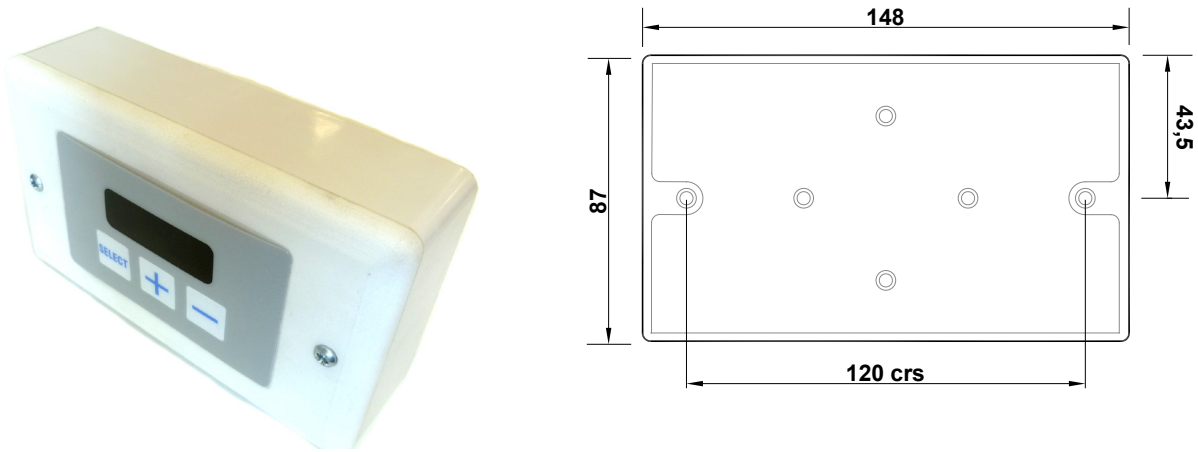
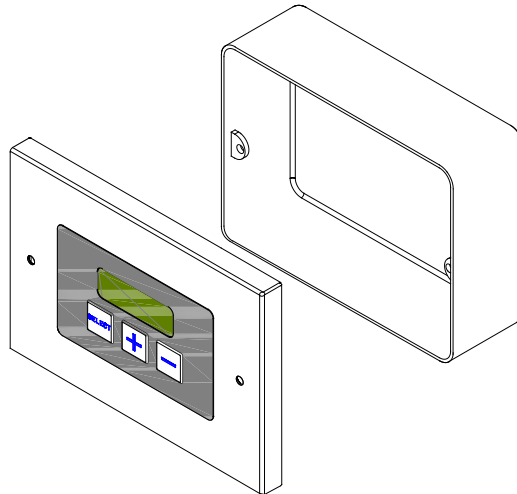

Fig.3. Optional flush mount using metal conduit box



3. Technical Specifications.

3.1 (Single Phase only)			ACR1000SE6-1PH	ACR1500SE6-1PH	ACR2000SE9-1PH
General Data					
Maximum height	M		3.0		
Door width		1.2	1.5	2.0	
Heat Medium	kW	Electrical heated			
Heat settings		3 / 6		4.5 / 9	
Fan type / dia		Crossflow / 100mm			
Fan settings		3 Speeds			
Switching type		3 tactile pushbuttons			
Weight	kg	28.0	34.0	49.0	
Electrical Data					
Supply voltage		230V 1ph 50Hz			
Total load	kW (a)	6.1 (26.5)		9.1 (39.6)	
Motor power	W	60		90	
Max Starting current*	amps	0.96		1.5	
Max Running current*	amps	0.65		0.75	
External fuse size amps	amps	32		45	
Programmer keypad	pt.no.	108221-RJ45			
Program keypad control wiring		RJ45 (pre-wired cable required)			
Cable terminal size		10.0mm ² MAX			
Mains terminal block position		Top of PCB (L1, N,E)			
RJ45 socket position		Centre of PCB (opposite mains input terminals)			
Air Data					
Air Volume	Low speed	m ³ /h	1164	1475	2013
	Medium speed	m ³ /h	1405	1780	2432
	High speed	m ³ /h	1646	2085	2851
Air Velocity	Low @ 0M	m/s	4.3		5.4
	Medium @ 0M	m/s	5.6		6.9
	High @ 0M	m/s	7.0		8.4
	High @ 1M	m/s	3.5		4.2
	High @ 2M	m/s	1.6		2.1
	High @ 3M	m/s	0.8		1.0
Delta T	Low speed	°C	17	13	26
	Medium speed	°C	15	11	23
	High speed	°C	13	9	20
Noise level @ 1M in free field	Low speed	dBA	59		
	Medium speed	dBA	62		
	High speed	dBA	64		
Dimensional Data					
Length	mm	1182	1482	1982	
Depth (width)	mm	395			
Total height	mm	200			
Outlet length	mm	1125	1425	1945	
Outlet depth (width)	mm	85			
Grille height	mm	40			
Mounting bracket centres length	mm	1220	1520	2020	
Side to 1st bracket centre	mm	18			
Mounting bracket centres height	mm			Flush with top of unit	
Top to 1st bracket centre	mm	Flush with top of unit			

* Motor current only at high speed

3.2			ACR1000SE9	ACR1500SE12	ACR2000SE18
General Data					
Maximum height	M		3.0		
Door width		1.2	1.5	2.0	
Heat Medium	kW	Electrical heated			
Heat settings		4.5 / 9	6 / 12	9 / 18	
Fan type / dia		Crossflow / 100mm			
Fan settings		3 speeds			
Switching type		3 tactile pushbuttons			
Weight	kg	28.0	34.0	49.0	
Electrical Data					
Supply voltage		415V 3ph 50Hz			
Total load	kW (a)	9.1 (12.6)	12.1 (16.8)	18.1 (25.2)	
Motor power	W	60		90	
Max Starting current*	amps	0.96		1.5	
Max Running current*	amps	0.65		0.75	
External fuse size amps	amps	16	20	32	
Programmer keypad	pt.no.	108221-RJ45			
Program keypad control wiring		RJ45 (pre-wired cable required)			
Cable terminal size		10.0mm ² MAX			
Mains terminal block position		Top of PCB (L1, L2, L3, N, E)			
RJ45 socket position		Centre of PCB (opposite mains input terminals)			
** SmartElec3 Energy Saving Control		108221-RJ45			
SmartElec3 Energy Saving Control wiring		RJ45 (pre-wired cable required)			
Cable terminal size		10.0mm ² Max			
Mains terminal block position		Top of PCB (L1, L2, L3, N, E)			
RJ45 socket position		Centre of PCB (opposite mains input terminals)			
Air Data					
Air Volume	Low speed	m ³ /h	1164	1475	2013
	Medium speed	m ³ /h	1405	1780	2432
	High speed	m ³ /h	1646	2085	2851
Air Velocity	Low @ 0M	m/s	4.3		5.4
	Medium @ 0M	m/s	5.6		6.9
	High @ 0M	m/s	7.0		8.4
	High @ 1M	m/s	3.5		4.2
	High @ 2M	m/s	1.6		2.1
	High @ 3M	m/s	0.8		1.0
Delta T	Low speed	°C	26	25	21
	Medium speed	°C	23	22	20
	High speed	°C	20	19	19
Noise level @ 1M in free field	Low speed	dBA	59		
	Medium speed	dBA	62		
	High speed	dBA	64		
Dimensional Data					
Length	mm	1182	1482	1982	
Depth (width)	mm	395			
Total height	mm	200			
Outlet length	mm	1125	1425	1945	
Outlet depth (width)	mm	85			
Grille height	mm	40			
Mounting bracket centres length	mm	1220	1520	2020	
Side to 1st bracket centre	mm	18			
Mounting bracket centres height	mm			Flush with top of unit	
Top to 1st bracket centre	mm	Flush with top of unit			

* Motor current only at high speed

**Suffix with -SM for SmartElec3 Energy Saving Control.

3.3		ACR1200HE12	ACR1800HE18	ACR2000HE18	
General Data					
Maximum height	M	4.0			
Door width		1.2	1.8	2.0	
Heat Medium	kW	Electrical heated			
Heat settings		6 / 12	9 / 18		
Fan type / dia		Crossflow / 100mm			
Fan settings		3 speeds			
Switching type		3 tactile pushbuttons			
Weight	kg	38.0	55.0	63.0	
Electrical Data					
Supply voltage		415V 3ph 50Hz			
Total load	kW (a)	12.4 (17.3)	18.4 (25.6)		
Motor power	W	370			
Max Starting current*	amps	5.0			
Max Running current*	amps	2.1			
External fuse size amps	amps	20	32		
Programmer keypad	pt.no.	108221-RJ45			
Program keypad control wiring		RJ45 (pre-wired cable required)			
Cable terminal size		10.0mm ² MAX			
Mains terminal block position		Top of PCB (L1, L2, L3, N, E)			
RJ45 socket position		Centre of PCB (opposite mains input terminals)			
** SmartElec3 Energy Saving Control		108221-RJ45			
SmartElec3 Energy Saving Control wiring		RJ45 (pre-wired cable required)			
Cable terminal size		10.0mm ² Max			
Mains terminal block position		Top of PCB (L1, L2, L3, N, E)			
RJ45 socket position		Centre of PCB (opposite mains input terminals)			
Air Data					
Air Volume	Low speed	m ³ /h	1300	1600	2900
	Medium speed	m ³ /h	1850	2400	4100
	High speed	m ³ /h	2300	3300	5000
Air Velocity	Low @ 0M	m/s	6.0		
	Medium @ 0M	m/s	8.5		
	High @ 0M	m/s	11.0		
	High @ 1M	m/s	5.4	5.5	5.2
	High @ 2M	m/s	3.6	3.7	3.6
	High @ 3M	m/s	2.6	2.5	2.4
	High @ 4M	m/s	1.5	1.6	1.4
Delta T	Low speed	°C	35		36
	Medium speed	°C	28	27	26
	High speed	°C	22		20
Noise level @ 1M in free field	Low speed	dBA	50		
	Medium speed	dBA	55		
	High speed	dBA	60		
Dimensional Data					
Length		1150	1750	2082	
Depth (width)		550			
Total height		227			
Outlet length		1090	1690	2022	
Outlet depth (width)		85			
Grille height		6			
Mounting bracket centres length		1185	1785	2117	
Side to 1st bracket centre		17.5			
Mounting bracket centres height		Flush with top of unit			
Top to 1st bracket centre		Flush with top of unit			

* Motor current only at high speed

**Suffix with -SM for SmartElec3 Energy Saving Control.
Doc No. D301021 Page 13 of 64

3.4		ACR1000SA	ACR1500SA	ACR2000SA	
General Data					
Maximum height	M	3.0			
Door width		1.2	1.5	2.0	
Heat Medium	kW	Ambient			
Fan type / dia		Crossflow / 100mm			
Fan settings		3			
Switching type		3 tactile pushbuttons			
Weight	kg	28.0	34.0	49.0	
Electrical Data					
Supply voltage		230V 1ph 50Hz			
Total load	kW (a)	0.06 (0.26)		0.09 (0.4)	
Motor power	W	60		90	
Max Starting current*	amps	0.96		1.5	
Max Running current*	amps	0.65		0.75	
External fuse size amps	amps	3			
Programmer keypad	pt.no.	108221-RJ45			
Program keypad control wiring		RJ45 (pre-wired cable required)			
Cable terminal size		1.5mm ² MAX			
Mains terminal block position		Top right of PCB (L1, N, E)			
RJ45 socket position		Right hand side of PCB (below mains input terminals)			
Air Data					
Air Volume	Low speed	m ³ /h	1164	1475	2013
	Medium speed	m ³ /h	1405	1780	2432
	High speed	m ³ /h	1646	2085	2851
Air Velocity	Low @ 0M	m/s	4.3		5.4
	Medium @ 0M	m/s	5.6		6.9
	High @ 0M	m/s	7.0		8.4
	High @ 1M	m/s	3.5		4.2
	High @ 2M	m/s	1.6		2.1
	High @ 3M	m/s	0.8		1.0
Noise level @ 1M in free field	Low speed	dB(A)	59		62
	Medium speed	dB(A)	62		64
	High speed	dB(A)	64		66
Dimensional Data					
Length	mm	1182	1482	1982	
Depth (width)	mm	395			
Total height	mm	200			
Outlet length	mm	1125	1425	1945	
Outlet depth (width)	mm	85			
Grille height	mm	40			
Mounting bracket centres length	mm	1220	1520	2020	
Side to 1st bracket centre	mm	18			
Mounting bracket centres height	mm		Flush with top of unit		
Top to 1st bracket centre	mm	Flush with top of unit			

* Motor current only at high speed

3.5			ACR1200HA	ACR1800HA	ACR2000HA
General Data					
Maximum height	M		4.0		
Door width		1.2	1.8	2.0	
Heat Medium	kW	Ambient			
Fan type / dia		Crossflow / 100mm			
Fan settings		3			
Switching type		3 tactile pushbuttons			
Weight	kg	38.0	55.0	63.0	
Electrical Data					
Supply voltage		230V 1ph 50Hz			
Total load	kW (a)	0.4 (1.61)			
Motor power	W	370			
Max Starting current*	amps	5.0			
Max Running current*	amps	2.1			
External fuse size amps	amps	10			
Programmer keypad	pt.no.	108221-RJ45			
Program keypad control wiring		RJ45 (pre-wired cable required)			
Cable terminal size		1.5mm ² MAX			
Mains terminal block position		Top right of PCB (L1, N, E)			
RJ45 socket position		Right hand side of PCB (below mains input terminals)			
Air Data					
Air Volume	Low speed	m ³ /h	1300	1600	2900
	Medium speed	m ³ /h	1850	2400	4100
	High speed	m ³ /h	2300	3300	5000
Air Velocity	Low @ 0M	m/s	6.0		
	Medium @ 0M	m/s	8.5		
	High @ 0M	m/s	11.0		
	High @ 1M	m/s	5.4	5.5	5.2
	High @ 2M	m/s	3.6	3.7	3.6
	High @ 3M	m/s	2.6	2.5	2.4
	High @ 4M	m/s	1.5	1.6	1.4
Noise level @ 1M in free field	Low speed	dB(A)	50		
	Medium speed	dB(A)	55		
	High speed	dB(A)	60		
Dimensional Data					
Length	mm	1150	1750	2082	
Depth (width)	mm	550			
Total height	mm	227			
Outlet length	mm	1090	1690	2022	
Outlet depth (width)	mm	85			
Grille height	mm	6			
Mounting bracket centres length	mm	1185	1785	2117	
Side to 1st bracket centre	mm	17.5			
Mounting bracket centres height	mm	Flush with top of unit			
Top to 1st bracket centre	mm	Flush with top of unit			

* Motor current only at high speed

3.6		ACR1000SW9	ACR1500SW12	ACR2000SW18	
General Data					
Maximum height	M	3.0			
Door width		1.2	1.5	2.0	
Heat Medium	kW	LPHW			
Heat settings		9	12	18	
Fan type / dia		Crossflow / 100mm			
Fan settings		3			
Switching type		3 tactile pushbuttons			
Weight	kg	28.0	34.0	49.0	
Electrical Data					
Supply voltage		230V 1ph 50Hz			
Total load	kW (a)	0.06 (0.26)		0.09 (0.4)	
Motor power	W	60		90	
Max Starting current*	amps	0.96		1.5	
Max Running current*	amps	0.65		0.75	
External fuse size amps	amps	3			
Programmer keypad	pt.no.	108221-RJ45			
Program keypad control wiring		RJ45 (pre-wired cable required)			
Cable terminal size		1.5mm ² MAX			
Mains terminal block position		Top right of PCB (L1, N, E)			
RJ45 socket position		Right hand side of PCB (below mains input terminals)			
Air Data					
Air Volume	Low speed	m ³ /h	1164	1475	2013
	Medium speed	m ³ /h	1405	1780	2432
	High speed	m ³ /h	1646	2085	2851
Air Velocity	Low @ 0M	m/s	4.3		5.4
	Medium @ 0M	m/s	5.6		6.9
	High @ 0M	m/s	7.0		8.4
	High @ 1M	m/s	3.5		4.2
	High @ 2M	m/s	1.6		2.1
	High @ 3M	m/s	0.8		1.0
Delta T	Low speed	°C	26	25	21
	Medium speed	°C	23	22	20
	High speed	°C	20	19	19
Noise level @ 1M in free field	Low speed	dBA	59		62
	Medium speed	dBA	62		64
	High speed	dBA	64		66
LPHW Data					
LPHW flow	l/s	0.20		0.40	
Fluid pressure drop	kPA	3.8	17.6	20	
Flow & return connection	mm	15		22	
Inlet temperature	°C	82			
Outlet temperature	°C	71			
Dimensional Data					
Length	mm	1182	1482	1982	
Depth (width)	mm	395			
Total height	mm	200			
Outlet length	mm	1125	1425	1945	
Outlet depth (width)	mm	85			
Grille height	mm	40			
Mounting bracket centres length	mm	1220	1520	2020	
Side to 1st bracket centre	mm	18			
Mounting bracket centres height	mm	Flush with top of unit			
Top to 1st bracket centre	mm	Flush with top of unit			

3.7			ACR1200HW12	ACR1800HW18	ACR2000HW18
General Data					
Maximum height	M			4.0	
Door width			1.2	1.8	2.0
Heat Medium	kW			LPHW	
Heat settings			12		18
Fan type / dia				Crossflow / 100mm	
Fan settings				3	
Switching type				3 tactile pushbuttons	
Weight	kg		38.0	55.0	63.0
Electrical Data					
Supply voltage				230V 1ph 50Hz	
Total load	kW (a)			0.4 (1.6)	
Motor power	W			370	
Max Starting current*	amps			5.0	
Max Running current*	amps			2.1	
External fuse size amps	amps			10	
Programmer keypad	pt.no.			108221-RJ45	
Program keypad control wiring				RJ45 (pre-wired cable required)	
Cable terminal size				1.5mm ² MAX	
Mains terminal block position				Top right of PCB (L1, N, E)	
RJ45 socket position				Right hand side of PCB (below mains input terminals)	
Air Data					
Air Volume	Low speed	m ³ /h	1300	1600	2900
	Medium speed	m ³ /h	1850	2400	4100
	High speed	m ³ /h	2300	3300	5000
Air Velocity	Low @ 0M	m/s		6.0	
	Medium @ 0M	m/s		8.5	
	High @ 0M	m/s		11.0	
	High @ 1M	m/s	5.4	5.5	5.2
	High @ 2M	m/s	3.6	3.7	3.6
	High @ 3M	m/s	2.6	2.5	2.4
	High @ 4M	m/s	1.5	1.6	1.4
Delta T	Low speed	°C		35	36
	Medium speed	°C	28	27	26
	High speed	°C		22	20
Noise level @ 1M in free field	Low speed	dBA		50	
	Medium speed	dBA		55	
	High speed	dBA		60	
LPHW Data					
LPHW flow	l/s		0.27	0.40	0.40
Fluid pressure drop	kPA		19	23	15
Flow & return connection	mm			15	
Inlet temperature	°C			82	
Outlet temperature	°C			71	
Dimensional Data					
Length	mm		1150	1750	2082
Depth (width)	mm			550	
Total height	mm			227	
Outlet length	mm		1090	1690	2022
Outlet depth (width)	mm			85	
Grille height	mm			6	
Mounting bracket centres length	mm		1185	1785	2117
Side to 1st bracket centre	mm			17.5	
Mounting bracket centres height	mm			Flush with top of unit	
Top to 1st bracket centre	mm			Flush with top of unit	

3.8	Standard Program Controls
General Data	
Sensor Input	NTC
Protection	1 x 1A fuse for the protection of the fan switching devices.
Fan Output	3 off Relay for High, Medium and Low Fan setting 3A max 230vac
Connections	Screw terminals 4 for supply, 6 for elements output, 4 for fan output, 2 for BMS (time) control, 2 for sensor input, 2 for external thermal trip, 2 for external door switch, 2 for 0-10v fan option, 2 for 0-5v fault output, 2 for filter blocked, 2 for unit temperature.
Supply	415 3Ph or 230V 1Ph dependent on model type.
Dimensions	Program panel 146mm(L) x 85mm(W) x 38mm(D) max.
Temperature	5 to 50 °C operating; -20 to 65 °C storage
Display	Three 7-segment LCD red for parameter display
Push Buttons	3 positive feedback tactile push buttons

3.9	SmartElec3 Controls
General Data	
Sensor Input	NTC
Control Setpoint	16 to 35 °C in steps of 1 degree
Temperature Control	Proportional with 1°C hysteresis
Minimum Power	0% to 99 %
Cycle Time	2 seconds fixed
Protection	2 x high speed fuse for the protection of the heater switching devices
Fan Output	3 off Relay for High, Medium and Low Fan setting 3A max 230Vac
Connections	Screw terminals 5 for supply, 3 for heater output, 4 for fan output, 2 for BMS (time) control, 2 for sensor input, 2 for external thermal trip, 2 for external sensor, 2 for door, 2 for cooling fan on 24kW models. RJ45 comms connection to base unit via pre-wired cable.
Supply	415V AC 50/60Hz 5VA max.
Dimensions	Program panel 146mm(L) x 85mm(W) x 38mm(D) max.
Mounting Positions	Program panel fixing centres 80mm x 20mm
Temperature	5 to 50 °C operating; -20 to 65 °C storage
Display	Three 7-segment LCD red for parameter display
Push Buttons	3 positive feedback tactile push buttons

3.10	LPHW/Ambient Controls
General Data	
Sensor Input	NTC
Control Setpoint	16 to 35 °C in steps of 1 degree
Temperature Control	0-10v valve output (proportional)
Cycle Time	2 seconds fixed
Protection	1 x 1A fuse for the protection of the mains input
Fan Output	3 off Relays for High, Medium and Low Fan setting 3A max 230Vac
Connections	Screw terminals 3 for mains supply, 4 for fan output, 2 for BMS (time) control, 2 for sensor input, 2 for external thermal trip, 2 for external sensor, 2 for door., 2 for 0-10v motor drive, 2 for 0-10v fan option, 2 for 0-5v fault output, 2 for pipe cold input, 2 for unit temperature input, RJ45 comms connection to base unit via pre-wired cable.
Supply	230 V 50/60Hz.
Dimensions	Program panel 146mm(L) x 85mm(W) x 38mm(D) max.
Temperature	5 to 50 °C operating; -20 to 65 °C storage
Display	Three 7-segment LCD red for parameter display
Push Buttons	3 positive feedback tactile push buttons

4. Wiring Diagrams.

4.1 Installer Wiring - Electrically Heated 6 & 9kW SINGLE PHASE ONLY

The program panel is connected to the base unit via a pre-wired RJ45 cable max length 100m.

 It is recommended that this cable is run separately within its own trunking to avoid external interference.

External switch inputs (eg Timer) to be volt free and wired via normally open contacts to terminal pair marked eg. 'timer' (contacts closed to enable). Remove relevant factory fitted jumper for any optional input.

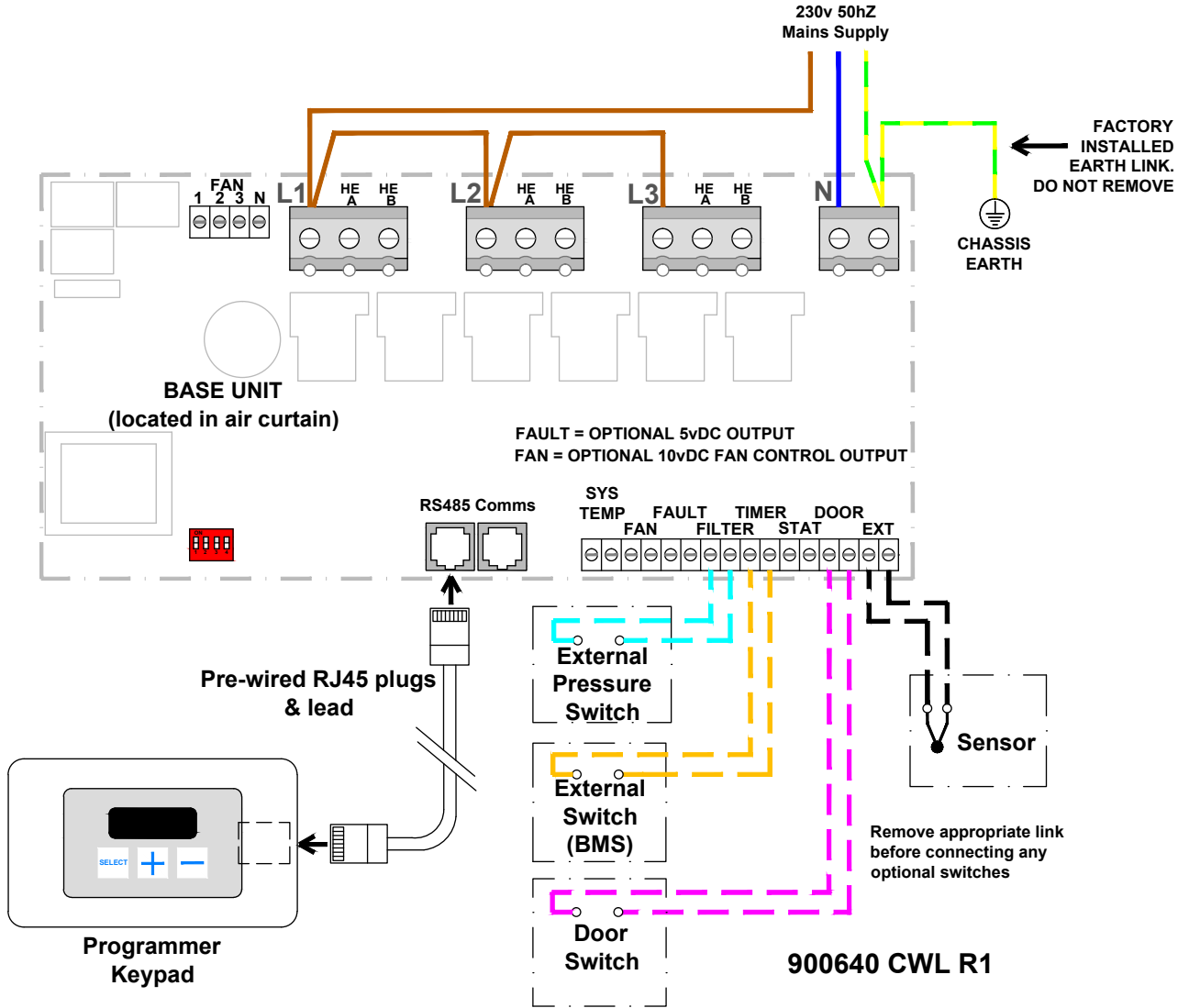

Terminal	Description	Cable
N	Neutral	10mm ² max
L1	Phase 1 (or 1 Phase supply)	
Pcb Terminal	Description	Cable
Door	Option door contact	1.5mm ² max
Timer BMS	Option external switch	

PCB Terminal	Description	Cable
Ext	Option internal/external sensor (supplied)	1.5mm ² max
Filter block	Option filter blocked switch	
Fail o/p	Fault output (0-5v)	
Fan	Option 0-10v fan output	
Pcb Fuses	Rating (A)	
F1	T1H (slow blow)	

Protection

External circuit breaker with the appropriate rating should be installed for the protection of the installation.

4.2 Installer Wiring - Electrically Heated 9, 12 & 18kW THREE PHASE ONLY

The program panel is connected to the base unit via a pre-wired RJ45 cable max length 100m.

 It is recommended that this cable is run separately within its own trunking to avoid external interference.

External switch inputs (eg Timer) to be volt free and wired via normally open contacts to terminal pair marked 'timer' (contacts closed to enable). Remove relevant factory fitted jumper for any optional input.

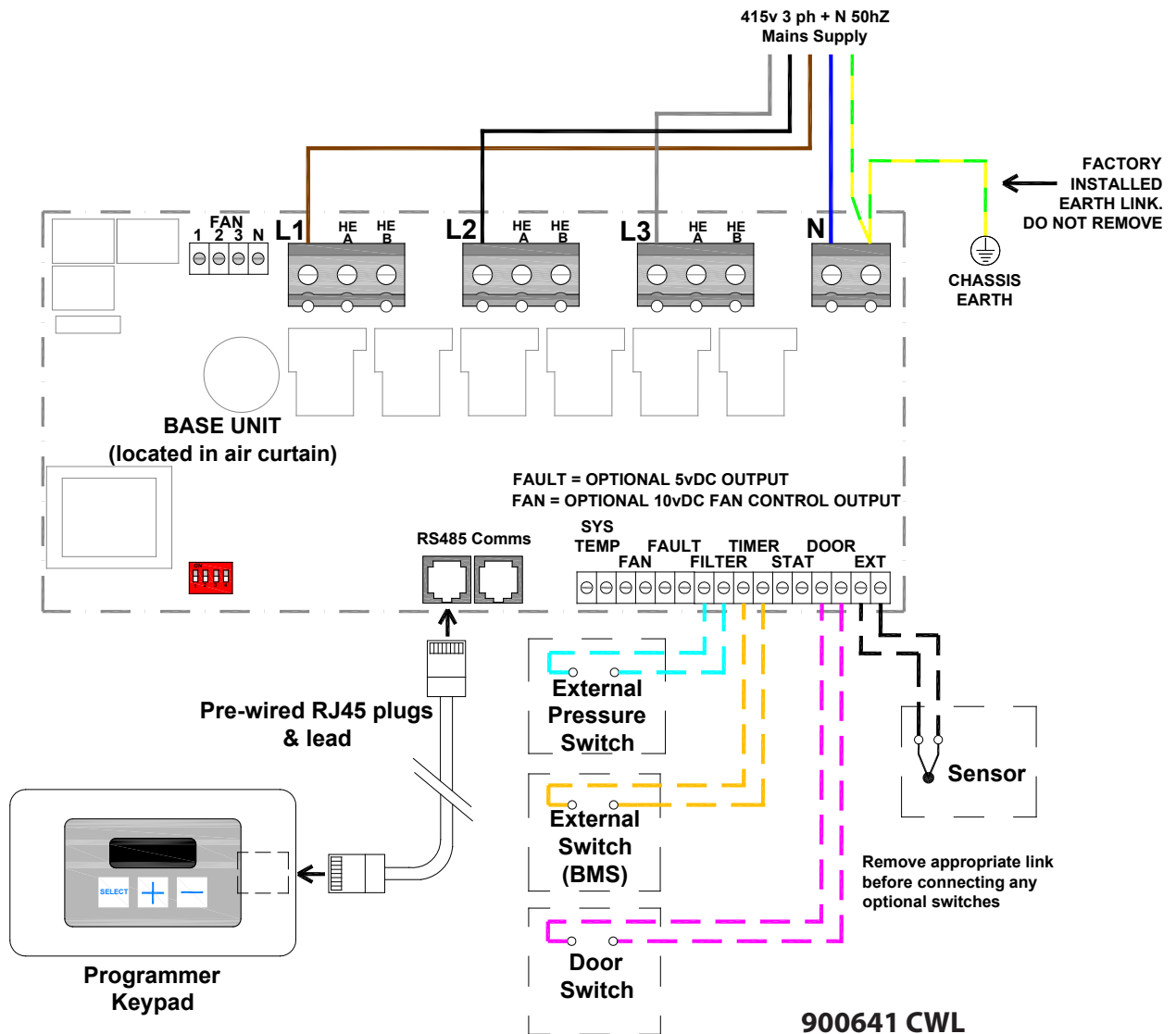

Terminal	Description	Cable
N	Neutral	10mm ² max
L1	Phase 1	
L2	Phase 2	
L3	Phase 3	
Pcb Terminal	Description	Cable
Door	Option door contact	1.5mm ² max
Timer/BMS	Option external switch	

PCB Terminal	Description	Cable
Ext	Option internal/external sensor (supplied)	1.5mm ² max
Filter block	Option filter blocked switch	
Fail o/p	Fault output (0-5v)	
Fan	Option 0-10v fan output	
Pcb Fuses	Rating (A)	
F1	T1H (slow blow)	

Protection

External circuit breaker with the appropriate rating should be installed for the protection of the installation.

4.3 Installer Wiring - Ambient

The program panel is connected to the base unit via a pre-wired RJ45 cable max length 100m.

 It is recommended that this cable is run separately within its own trunking to avoid external interference.

External switch inputs (eg Timer) to be volt free and wired via normally open contacts to terminal pair marked 'timer' (contacts closed to enable). Remove relevant factory fitted jumper for any optional input.

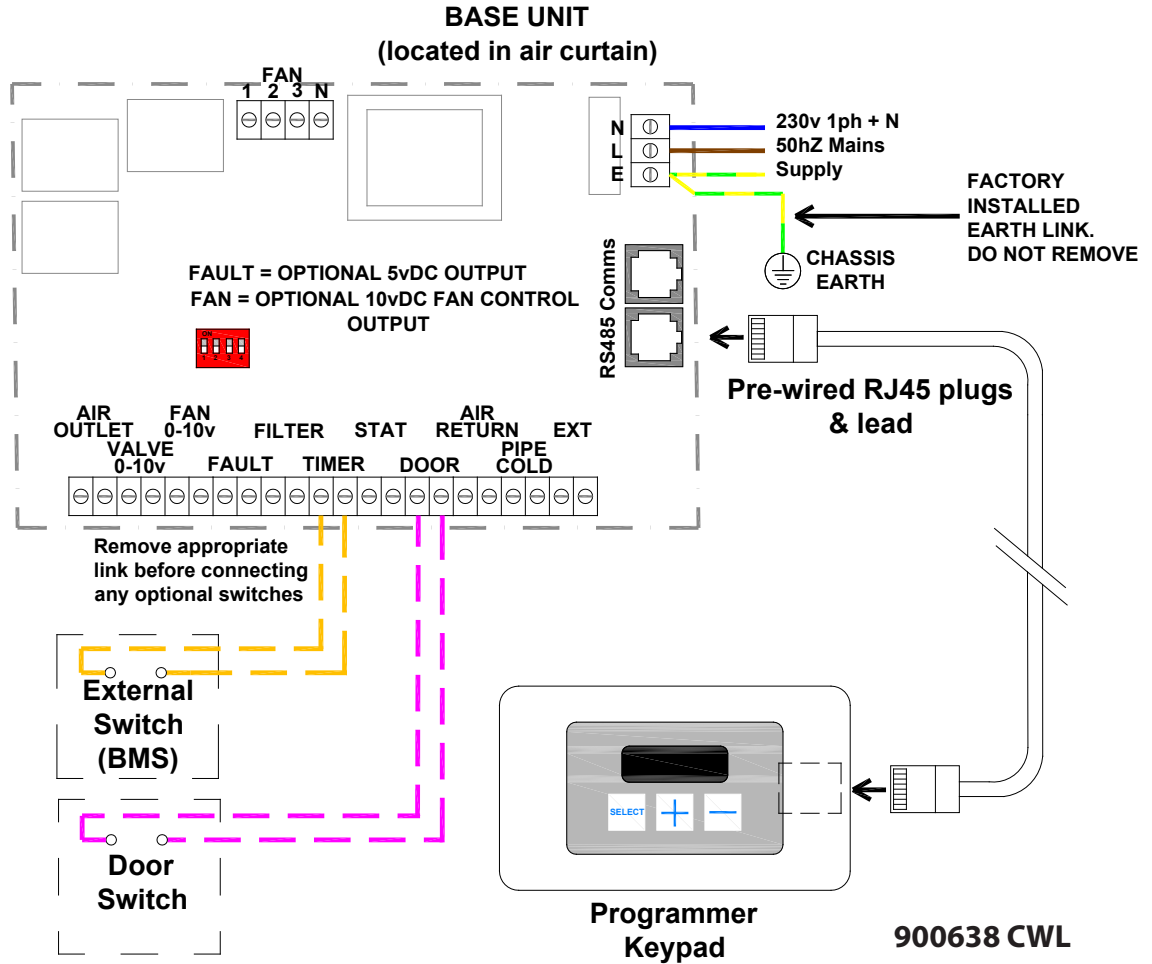

Terminal	Description	Cable
N	Neutral	1.5mm ² max
L	1 Phase supply	
Pcb Terminal	Description	
Door	Option door contact	
Timer BMS	Option external switch	
Ext	Option internal/external sensor (supplied)	

Terminal	Description	Cable
Filter block	Option filter blocked switch	1.5mm ² max
Fail o/p	Fault output (0-5v)	
Fan 0-10v	Option 0-10v fan output	
Valve 0-10v	Option 0-10v valve output	
Pcb Fuses	Rating (A)	
F1	T1H (slow blow)	

Protection

External circuit breaker with the appropriate rating should be installed for the protection of the installation.

4.4 Installer Wiring - LPHW

The program panel is connected to the base unit via a pre-wired RJ45 cable max length 100m.

! It is recommended that this cable is run separately within its own trunking to avoid external interference. External switch inputs (eg Timer) to be volt free and wired via normally open contacts to terminal pair marked 'timer' (contacts closed to enable). Remove relevant factory fitted jumper for any optional input.

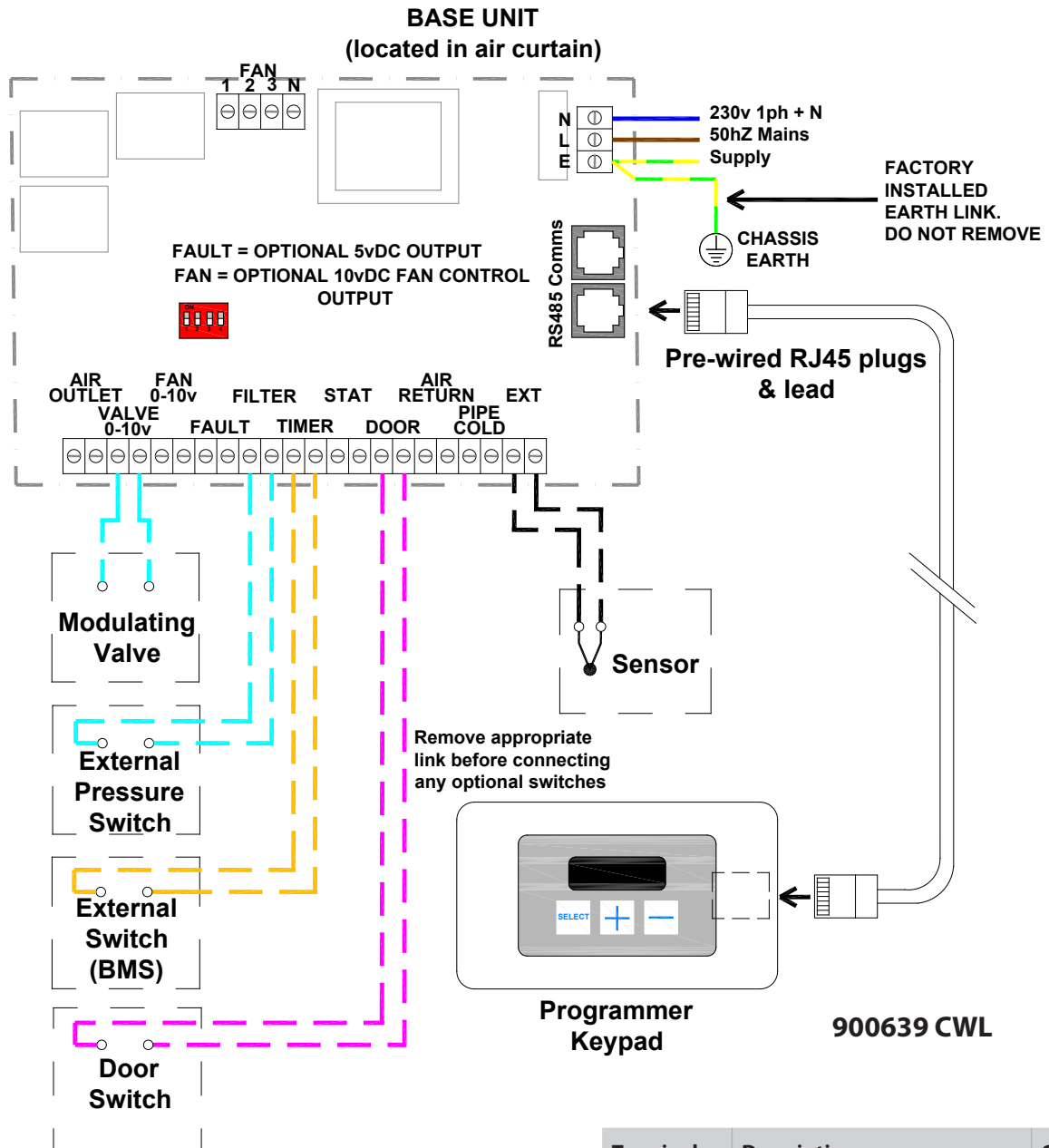

Terminal	Description	Cable
N	Neutral	1.5mm ² max
L	1 Phase supply	
Pcb Terminal	Description	
Door	Option door contact	
Timer BMS	Option external switch	
Ext	Option internal/external sensor (supplied)	
Air return	Option sensor	

Terminal	Description	Cable
Pipe cold	Option sensor	1.5mm ² max
Fail o/p	Fault output (0-5v)	
Fan	Option 0-10v fan output	
Valve	Option 0-10v valve output	
Filter block	Option filter blocked switch	
Pcb Fuses	Rating (A)	
F1	T1H (slow blow)	

Protection

External circuit breaker with the appropriate rating should be installed for the protection of the installation.

4.5 Factory Wiring - Electrically heated ACR1000/ACR1500 6kW SINGLE PHASE ONLY

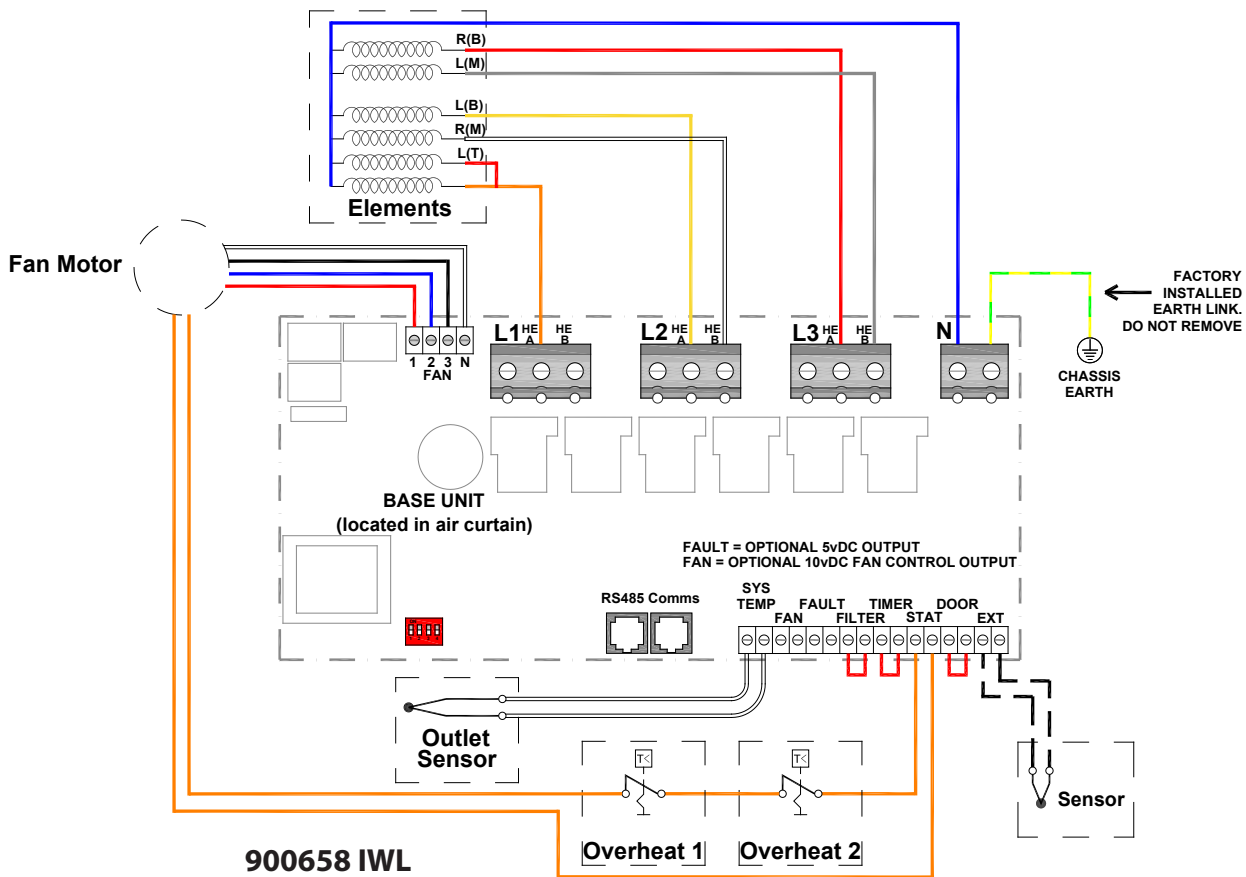

The element output is connected to the terminal blocks marked "L1 A", "L2 A&B", "L3 A&B" "N"

The fan output is connected to a 4 way connector marked "Fan 1, 2, 3 & N"

The thermal trips are connected to a 2 way connector marked "Stat"

Terminal	Description
N	Neutral
L	1 Phase supply
L1A,L2 A&B	2 thirds heating elements
L3 A&B	1 third heating elements
Pcb Terminal	Description
Stat	Thermal overheat trip
Ext	Option internal/external sensor (supplied)
Fan 1	Fan - Low speed
Fan 2	Fan - medium speed
Fan 3	Fan - high speed
Filter	Factory link
Timer	Factory link
Door	Factory link

4.6 Factory Wiring - Electrically heated ACR2000 9kW SINGLE PHASE ONLY

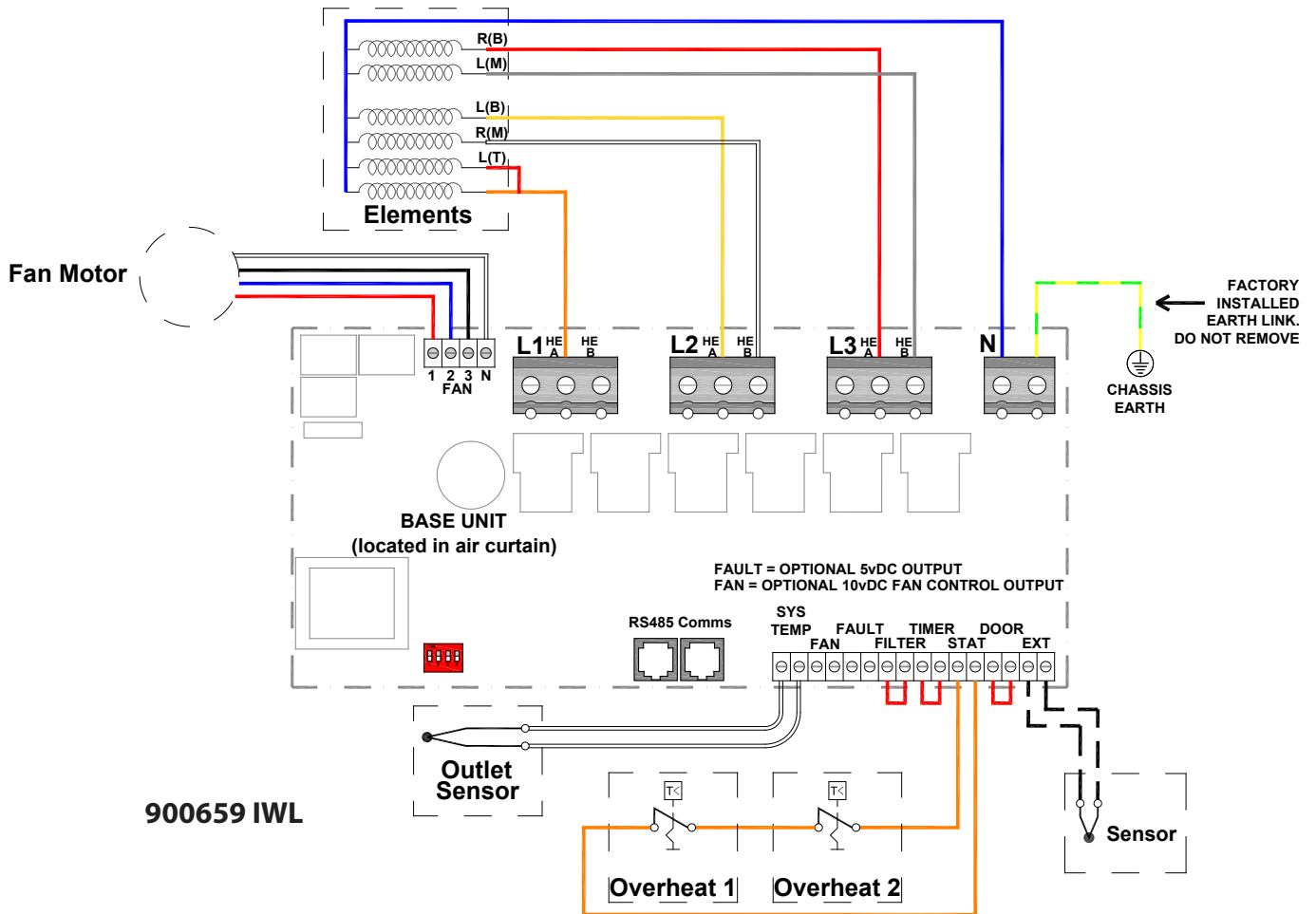

The element output is connected to the terminal blocks marked "L1 A", "L2 A&B", L3 A&B"

The fan output is connected to a 4 way connector marked "Fan 1, 2, 3 & N"

The thermal trips are connected to a 2 way connector marked "Stat"

Terminal	Description
N	Neutral
L	1 Phase supply
L1A,L2 A&B	2 thirds heating elements
L3 A&B	1 third heating elements
Pcb Terminal	Description
Stat	Thermal overheat trip
Ext	Option internal/external sensor (supplied)
Fan 1	Fan - Low speed
Fan 2	Fan - medium speed
Fan 3	Fan - high speed
Filter	Factory link
Timer	Factory link
Door	Factory link

4.7 Factory Wiring - Electrically heated ACR1000/ACR1500 9 & 12kW THREE PHASE ONLY

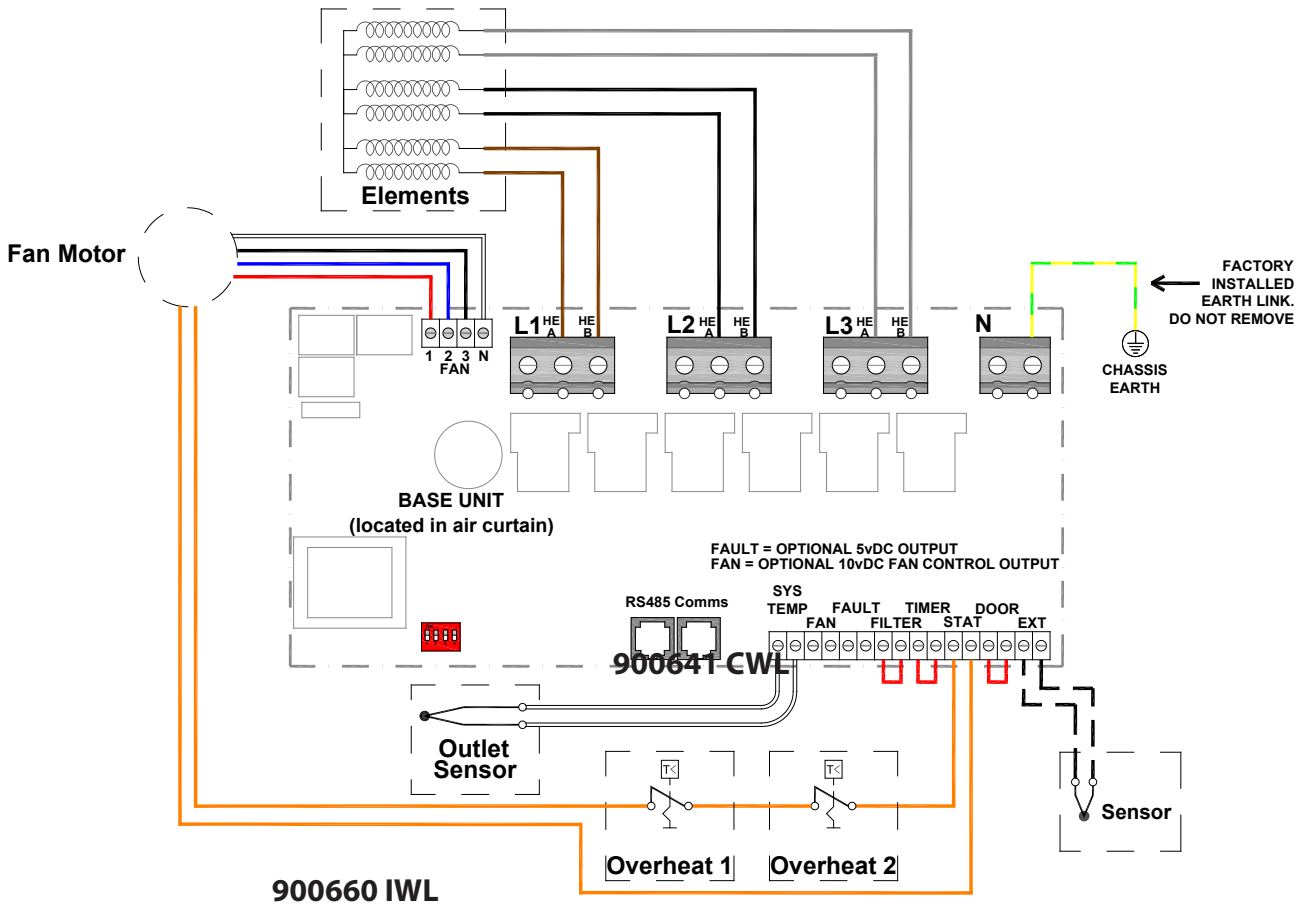

The element output is connected to the right and left side of each terminal block marked "HE A" & "HE B"

The fan output is connected to a 4 way connector marked "Fan 1,2,3 & N"

The thermal trips are connected to a 2 way connector marked "Stat"

Terminal	Description
L1,L2 & L3 HE A	One half of heating elements
L1,L2 & L3 HE B	Second half of heating elements
Pcb Terminal	Description
Stat	Thermal Overheat trip
Ext	Option internal/external sensor (supplied)
N	Neutral
Fan 1	Fan - low speed
Fan 2	Fan - medium speed
Fan 3	Fan - high speed
Filter	Factory link
Timer	Factory link
Door	Factory link

4.8 Factory Wiring - Electrically heated ACR1200/1800/2000 HE 12 & 18kW ACR 2000 SE 18kW THREE PHASE ONLY

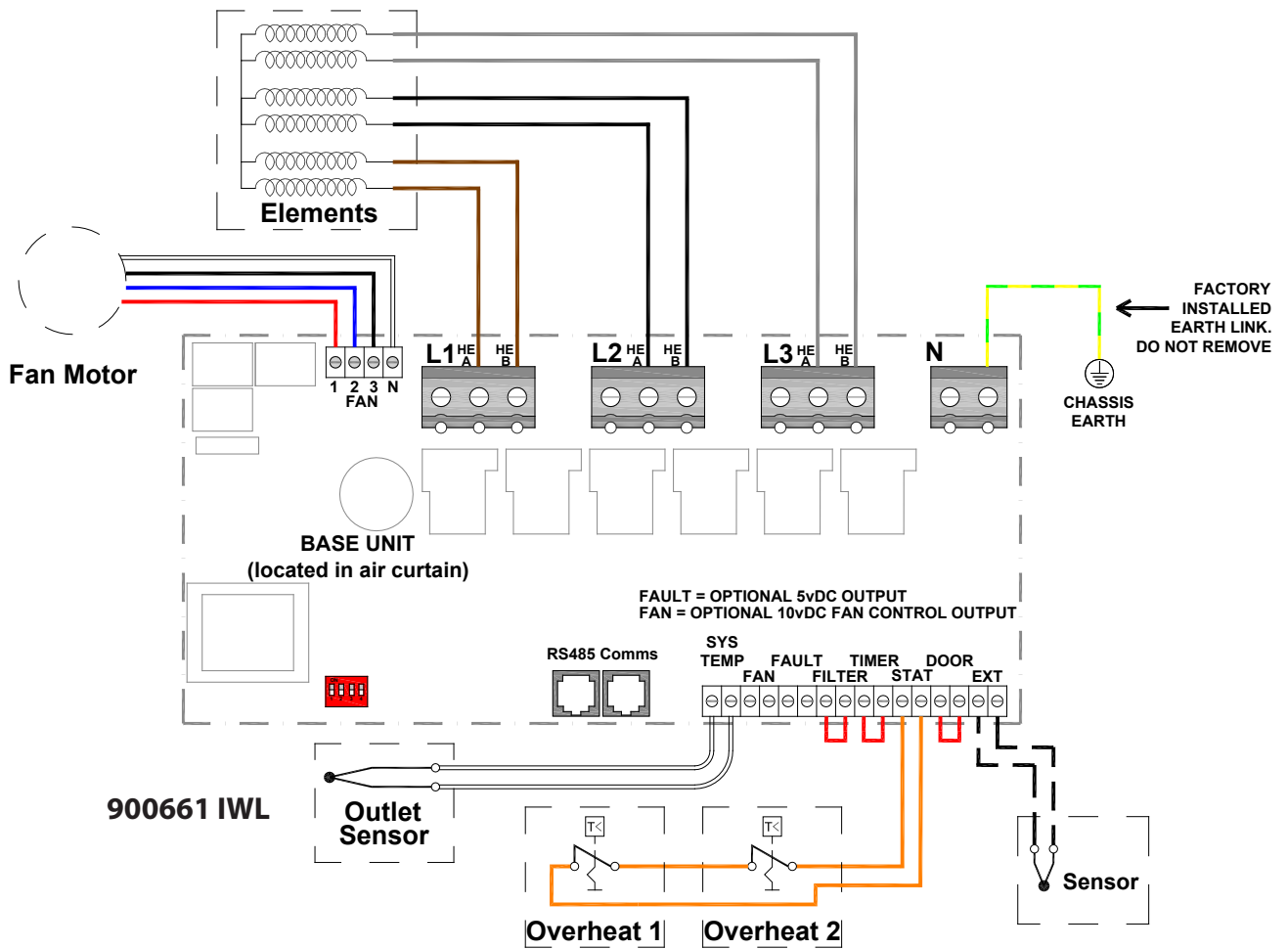

The element output is connected to the right and left side of each terminal block marked "HE A" & "HE B"

The fan output is connected to a 4 way connector marked "Fan 1,2,3 & N"

The thermal trips are connected to a 2 way connector marked "Stat"

Terminal	Description
L1,L2 & L3 HE A	One half of heating elements
L1,L2 & L3 HE B	Second half of heating elements
Pcb Terminal	Description
Stat	Thermal Overheat trip
Ext	Option internal/external sensor (supplied)
Fan 1	Fan - low speed
Fan 2	Fan - medium speed
Fan 3	Fan - high speed
Filter	Factory link
Timer	Factory link
Door	Factory link

4.9 Factory Wiring - Ambient ACR1000SA/ACR1500SA

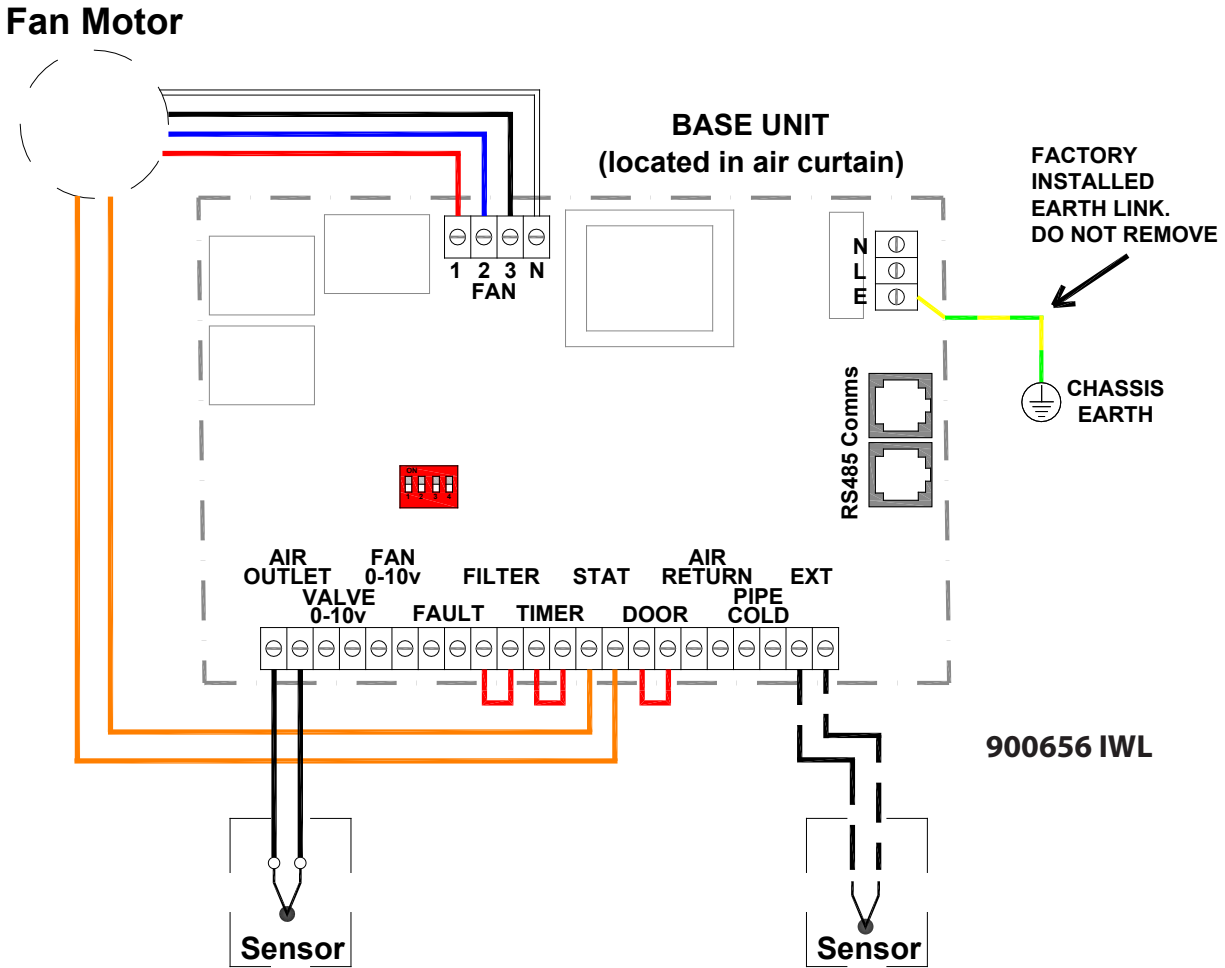

The fan output is connected to a 4 way connector marked "Fan 1,2,3 & N"

The motor thermal trip is connected to a 2 way connector marked "Stat"

Pcb Terminal	Description
Fan 1	Fan - low speed
Fan 2	Fan - medium speed
Fan 3	Fan - high speed
Filter	Factory link
Timer	Factory link
Door	Factory link
Stat	Motor thermal trip
Ext	Option internal/external sensor (supplied)
Air outlet	Air outlet sensor

4.10 Factory Wiring - Ambient ACR1200HA/ACR1800HA/ACR2000HA ACR2000SA

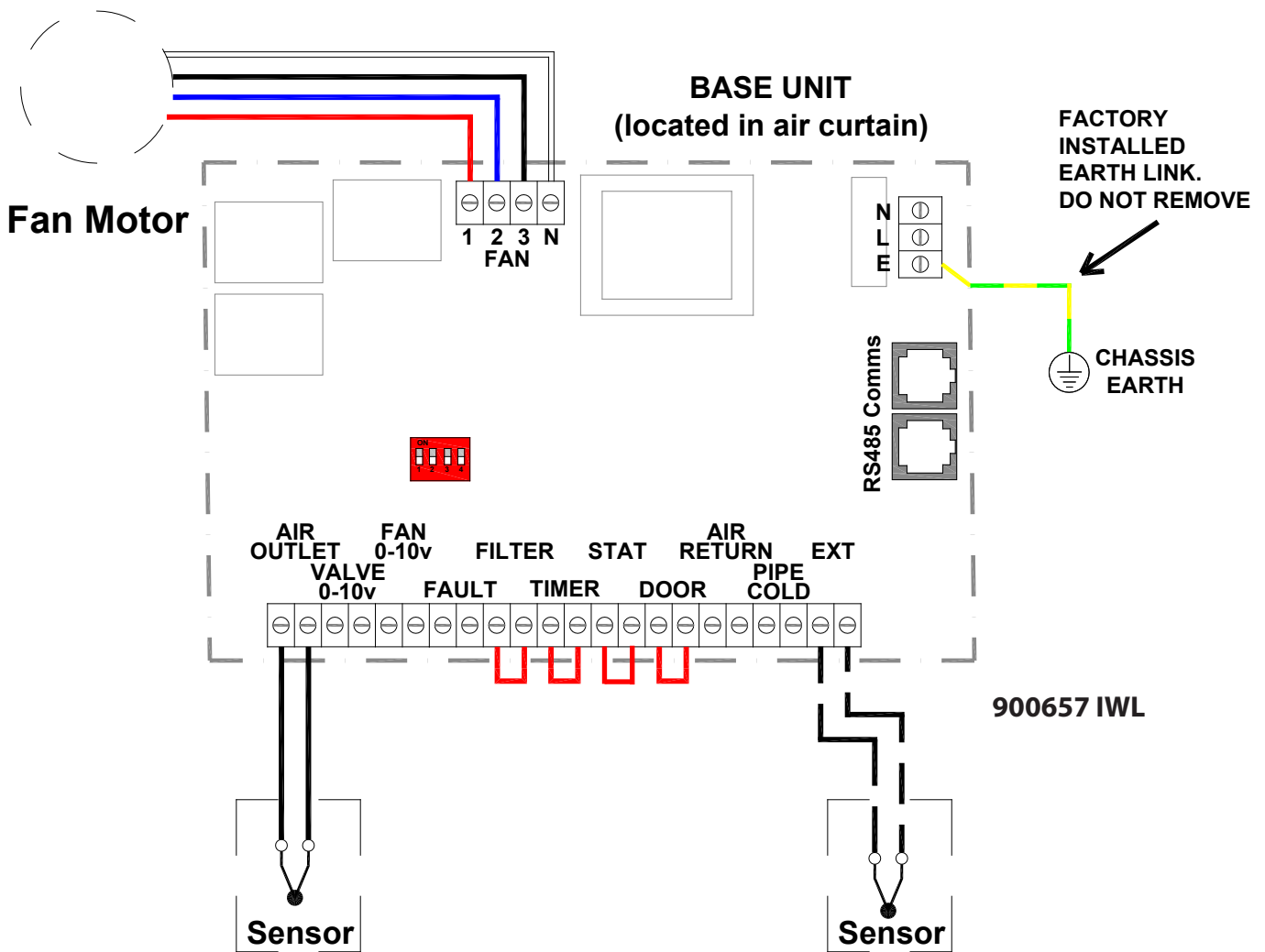

The fan output is connected to a 4 way connector marked "Fan 1,2,3 & N"

Pcb Terminal	Description
Fan 1	Fan - low speed
Fan 2	Fan - medium speed
Fan 3	Fan - high speed
Filter	Factory link
Timer	Factory link
Door	Factory link
Ext	Option internal/external sensor (supplied)
Air outlet	Air outlet sensor

4.11 Factory Wiring - LPHW ACR1000SW/ACR1500SW

Fan Motor

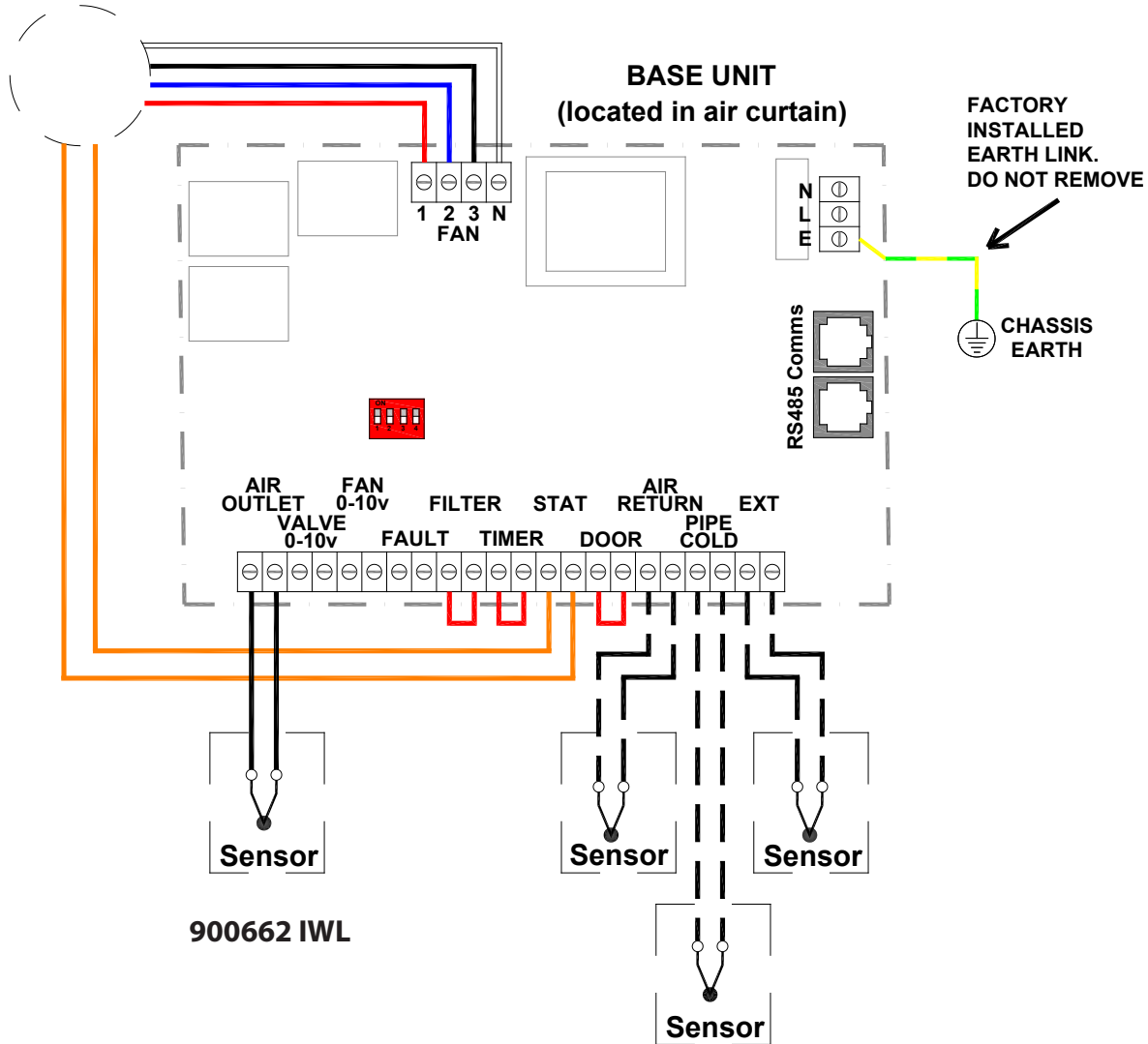

The fan output is connected to a 4 way connector marked "Fan 1,2,3 & N"

The motor thermal trip is connected to a 2 way connector marked "Stat"

Pcb Terminal	Description
Fan 1	Fan - low speed
Fan 2	Fan - medium speed
Fan 3	Fan - high speed
Filter	Factory link
Timer	Factory link
Door	Factory link
Stat	Motor thermal trip
Air return	Sensor (supplied)
Pipe cold	Sensor (supplied)
Ext	Option internal/external sensor (supplied)
Air outlet	Air outlet sensor

4.12 Factory Wiring - LPHW ACR1200HW/ACR1800HW/ACR2000HW ACR2000SW18

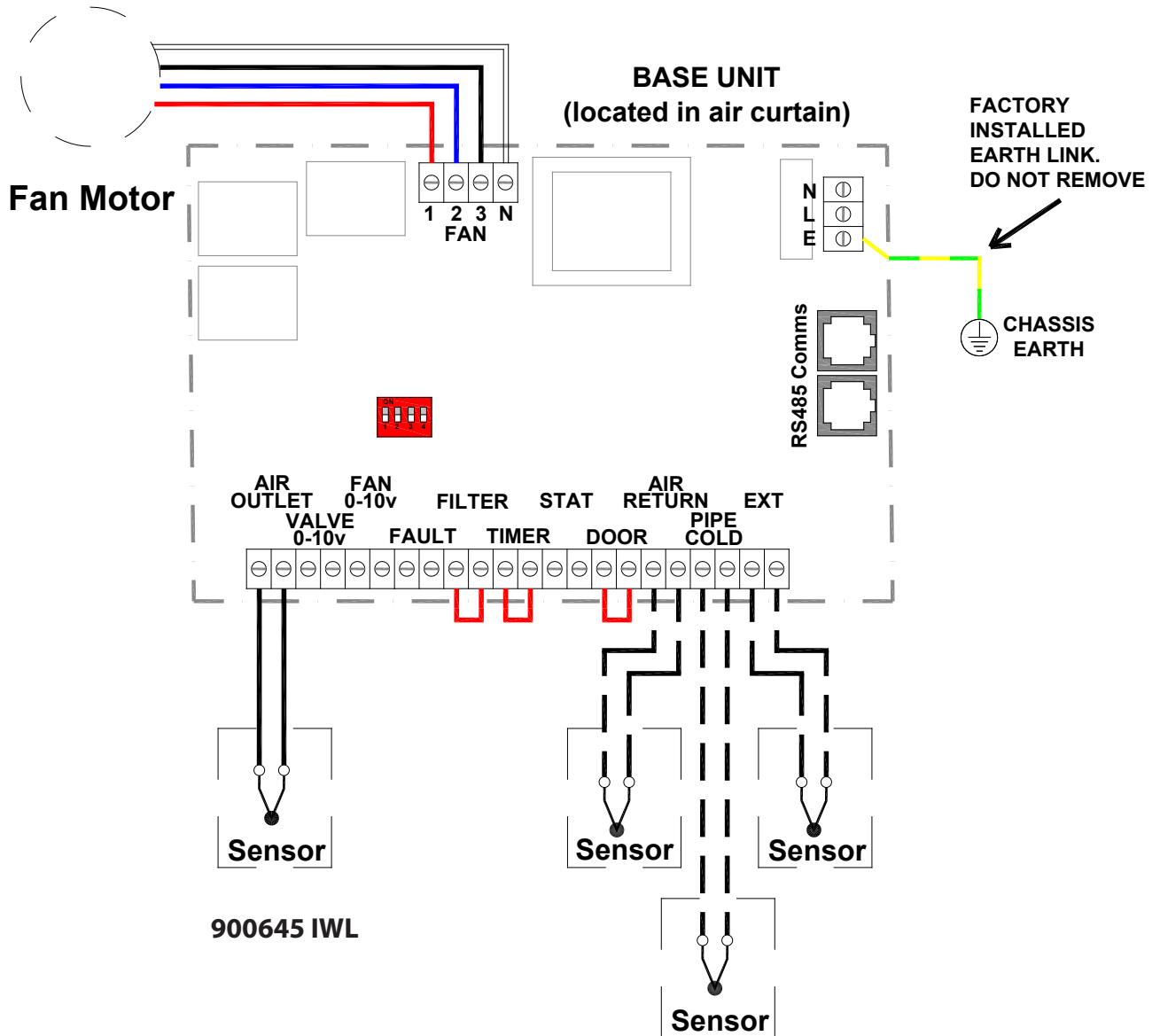

The fan output is connected to a 4 way connector marked "Fan 1,2,3 & N"

Pcb Terminal	Description
Fan 1	Fan - low speed
Fan 2	Fan - medium speed
Fan 3	Fan - high speed
Filter	Factory link
Timer	Factory link
Door	Factory link
Air return	Sensor (supplied)
Pipe cold	Sensor (supplied)
Ext	Option internal/external sensor (supplied)
Air outlet	Air outlet sensor

4.13 Network Wiring - Ambient/LPHW

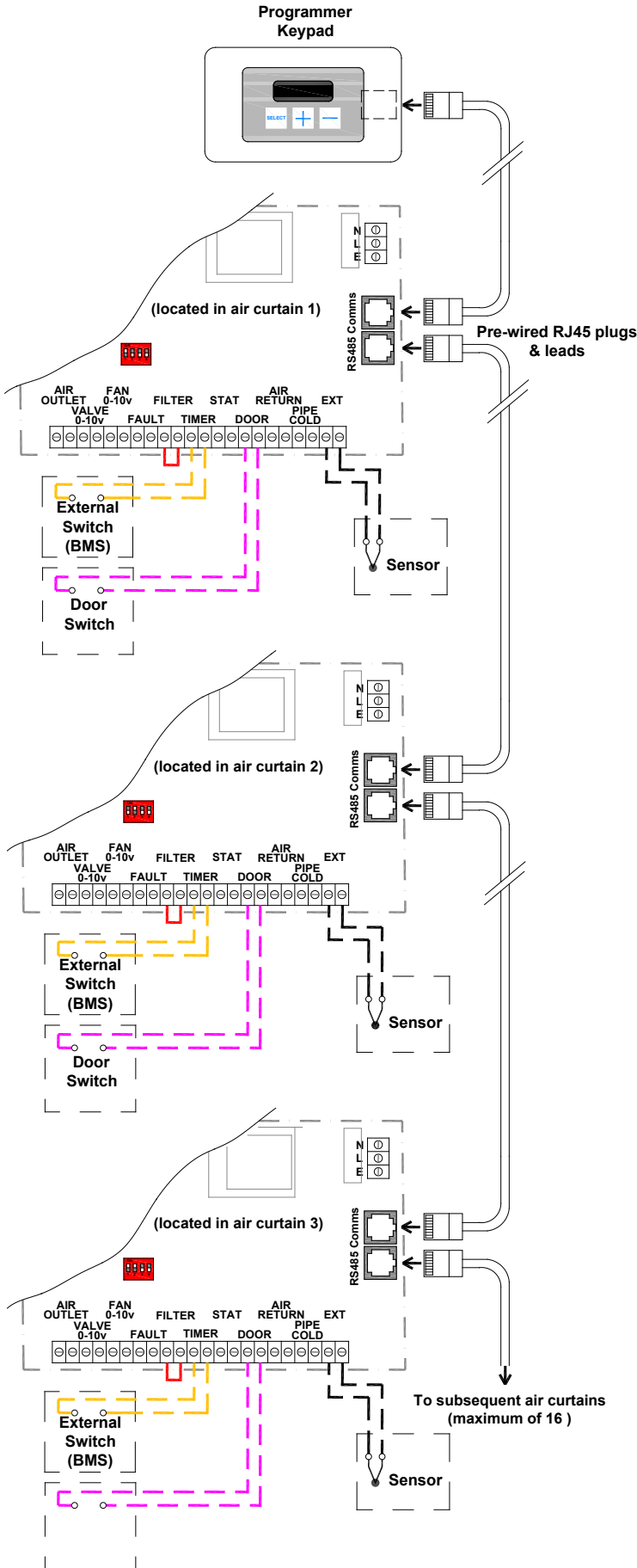

Networking

This diagram refers only to the wiring of 2 or more networked air curtains. (maximum 16 air curtains per control panel). For mains wiring refer to section 4 of this manual 'installer wiring details'.

The program panel is connected to the base unit in the first air curtain via pre-wired lead fitted with RJ45 plugs.

Each subsequent air curtain is wired with the same type of lead.

⚠ Max length 100m. (Total length of cable used between program panel and last air curtain in network).

It is recommended that this control cable is run separately within its own trunking if possible to avoid external interference.

! *Note: All air curtains connected within the network system can be controlled under the user settings of the single keypad.*

For more information on setup and control please refer to section 10 'User and Operating Instructions'.

⚠ ON AN INDIVIDUAL BASIS!

4.14 Network Wiring - Electrically heated

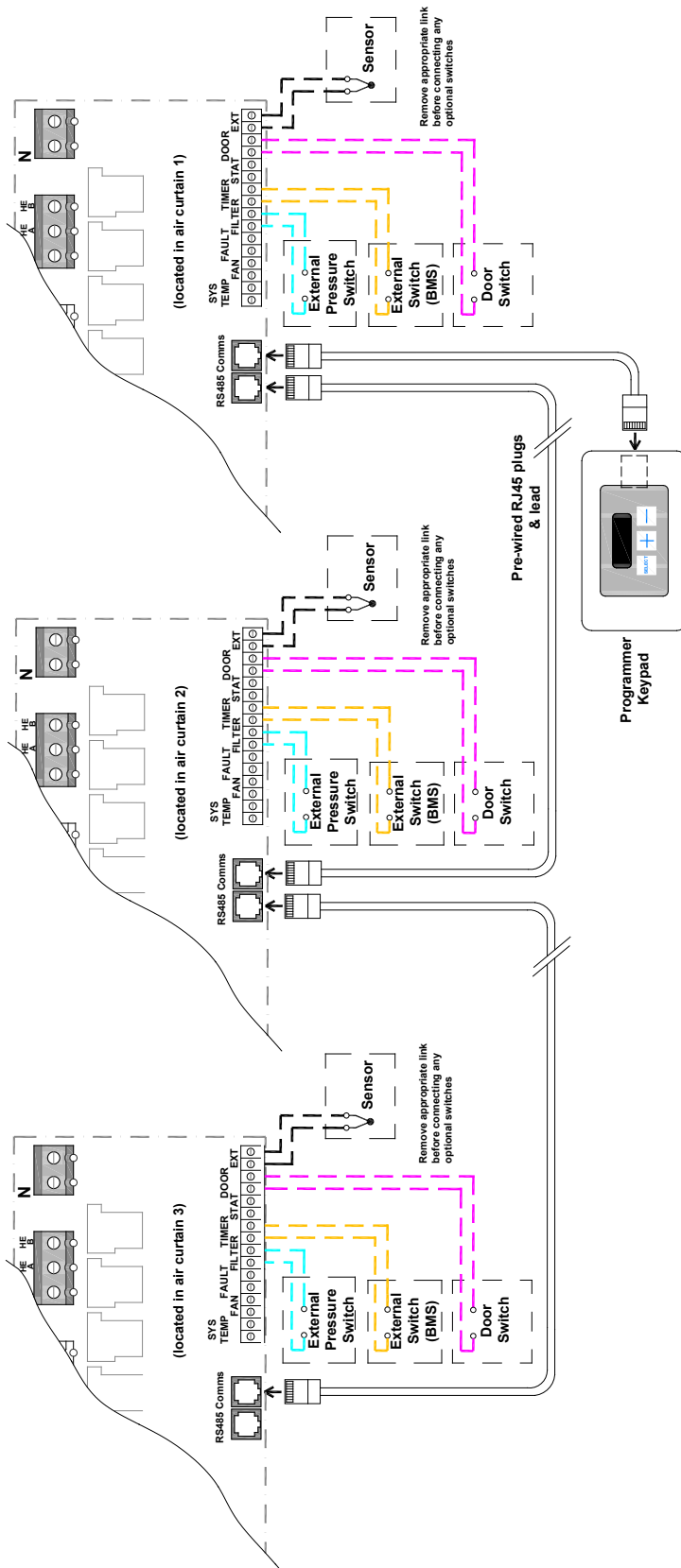

Networking

This diagram refers only to the wiring of 2 or more networked air curtains. (maximum 16 air curtains per control panel). For mains wiring refer to section 4 of this manual 'installer wiring details'.

The program panel is connected to the base unit in the first air curtain via pre-wired lead fitted with RJ45 plugs.

Each subsequent air curtain is wired with the same type of lead.

! **Max length 100m.** (Total length of cable used between program panel and last air curtain in network).

It is recommended that this control cable is run separately within its own trunking if possible to avoid external interference.

! *Note: All air curtains connected within the network system can be controlled under the user settings of the single keypad.*

For more information on setup and control please refer to section 10 'User and Operating Instructions'.

4.15 Installer wiring SmartElec3 control.

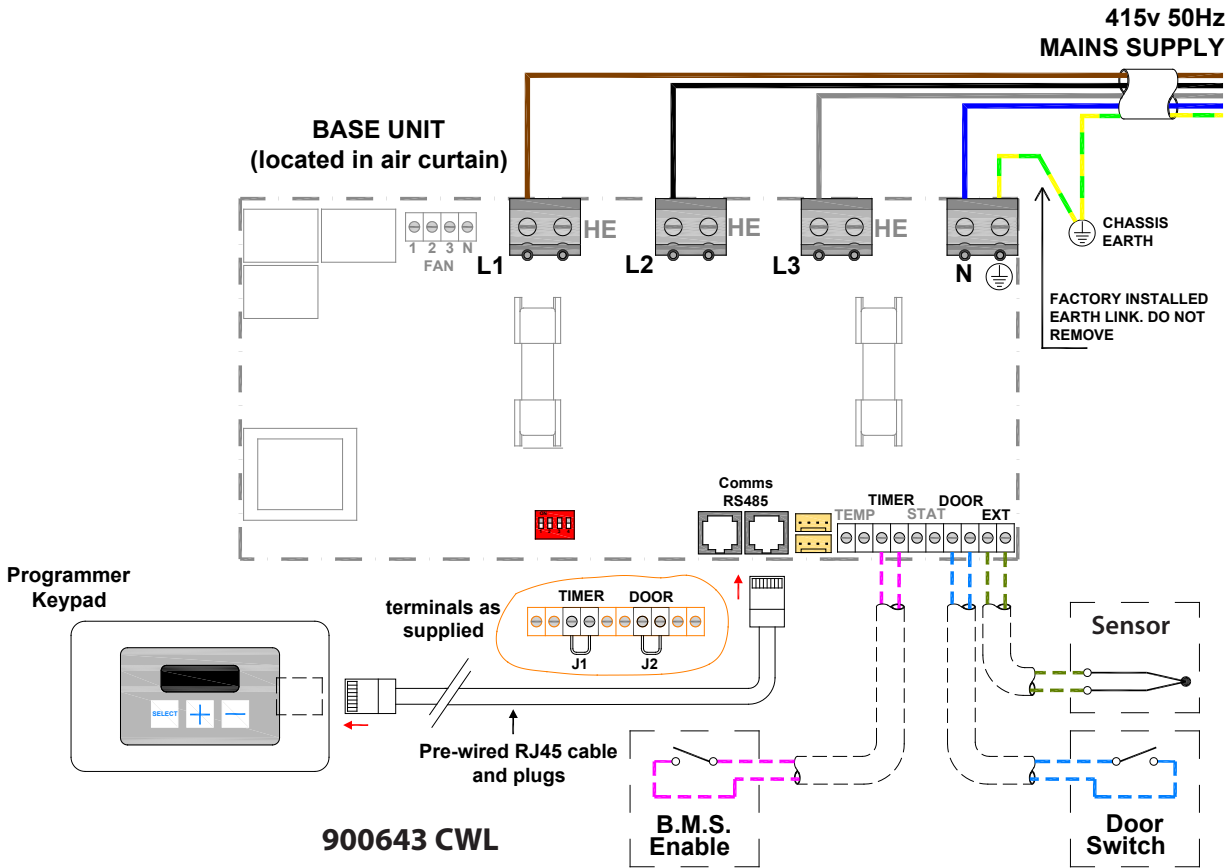

Interconnecting wiring

The program panel is connected to the base unit via a pre-wired RJ45 cables as shown and supplied in 2, 10, 20, 30, 50 and 100m lengths.

 It is recommended that this control cable is run separately within its own trunking where possible to avoid external interference.

Optional wiring

External switch (ie BMS enable) to be volt free and wired via normally open contacts to terminal pair 'TIMER'. (Contacts closed to enable). Remove factory fitted jumper J1.

Door switch to be volt free and wired via normally closed contacts to terminal pair 'DOOR'. (Contacts open to enable door mode). Remove factory fitted jumper. refer section 10.2.6.1 - Door link settings.

Internal/external sensor to be wired to terminal pair 'EXT'. refer section 10.2.6.4 - External Temperature.

Protection

There are two high speed fuses on the base unit to protect the switching thyristors for the heater. An external circuit breaker with the appropriate rating should be installed for the protection of the installation.

Terminal	Description	Cable
N	Neutral	10mm ² max
L1	3 Phase supply	
L2	3 Phase supply	
L3	3 Phase supply	
E	Mains Earth	1.5mm ² max
Timer	BMS pair (volt -free)	
Door	Door interlock pair, n.c. (volt free)	
Ext	Option internal/external sensor pair (supplied)	

4.16 Factory Installed Wiring. ACR1000/ACR1500 with SmartElec3 Control.

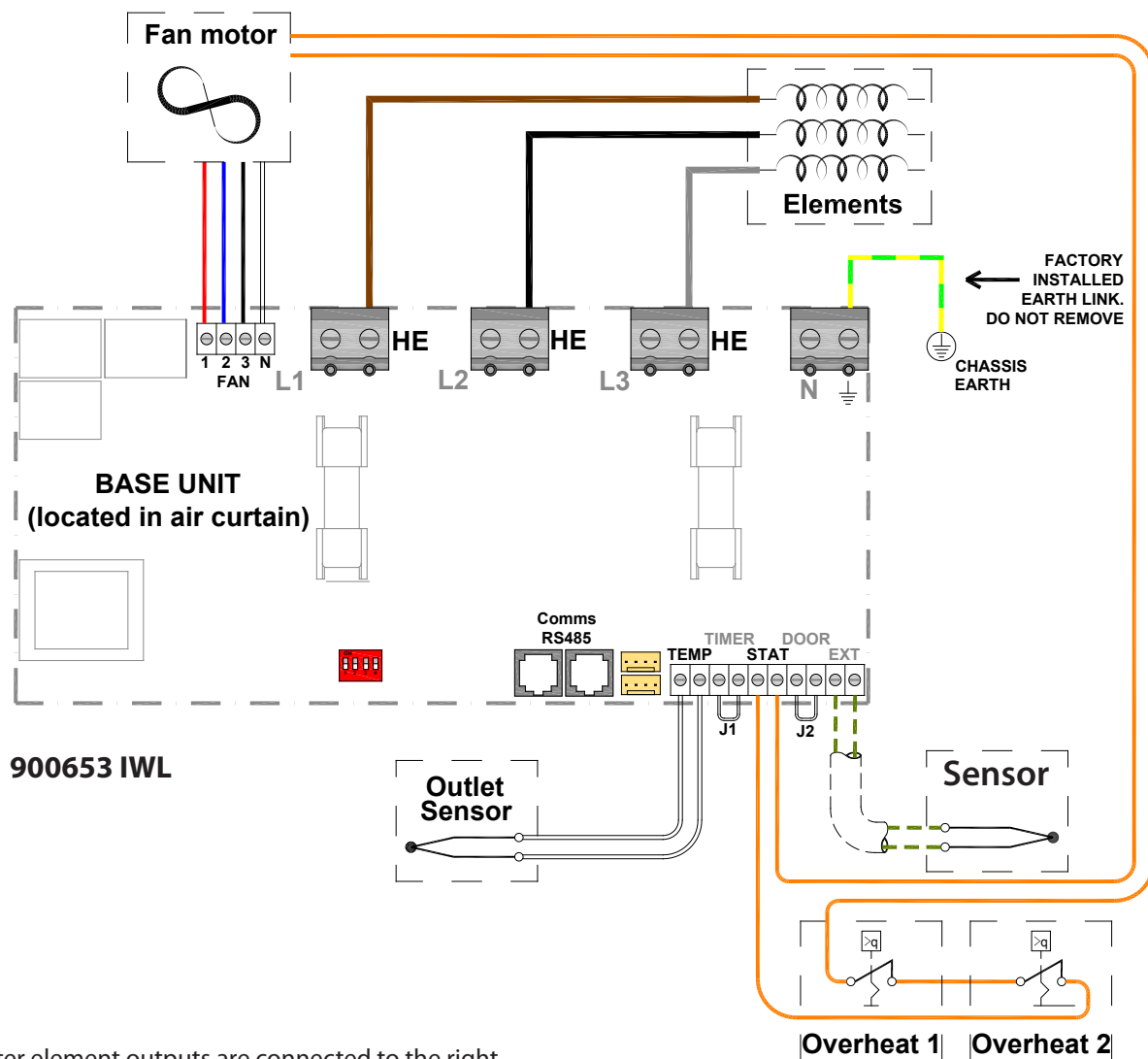

The heater element outputs are connected to the right hand side of three terminal blocks and are marked 'HE'. (See below).

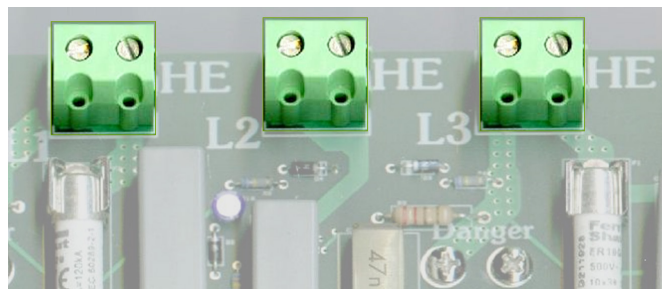

The fan output is connected to a 4 way terminal block marked 'N, 1, 2 and 3'.

The sensor input (air sensor) is connected to 2 terminals marked 'TEMP' on the base unit. The sensor is not polarity sensitive.

The external thermal trip (volt-free) is connected to 2 terminals marked 'STAT' on the base unit. The terminals are not polarity sensitive.

Terminal	Description	Cable
HE	Heating elements phase 1	10mm ² max
HE	Heating elements phase 2	
HE	Heating elements phase 3	
N	Neutral to fan	1.5mm ² max
Fan 1	Fan - low speed	
Fan 2	Fan - medium speed	
Fan 3	Fan - high speed	
Temp	Air sensor pair (non-polarised)	RJ45
Stat	Ext thermal trip pair, n.c. (volt-free)	
Ext	Option internal/external sensor (supplied)	
Comms	Keypad/network connectors	

4.17 Factory Installed Wiring. ACR1200/ACR1800HE/ACR2000HE with SmartElec3 Control

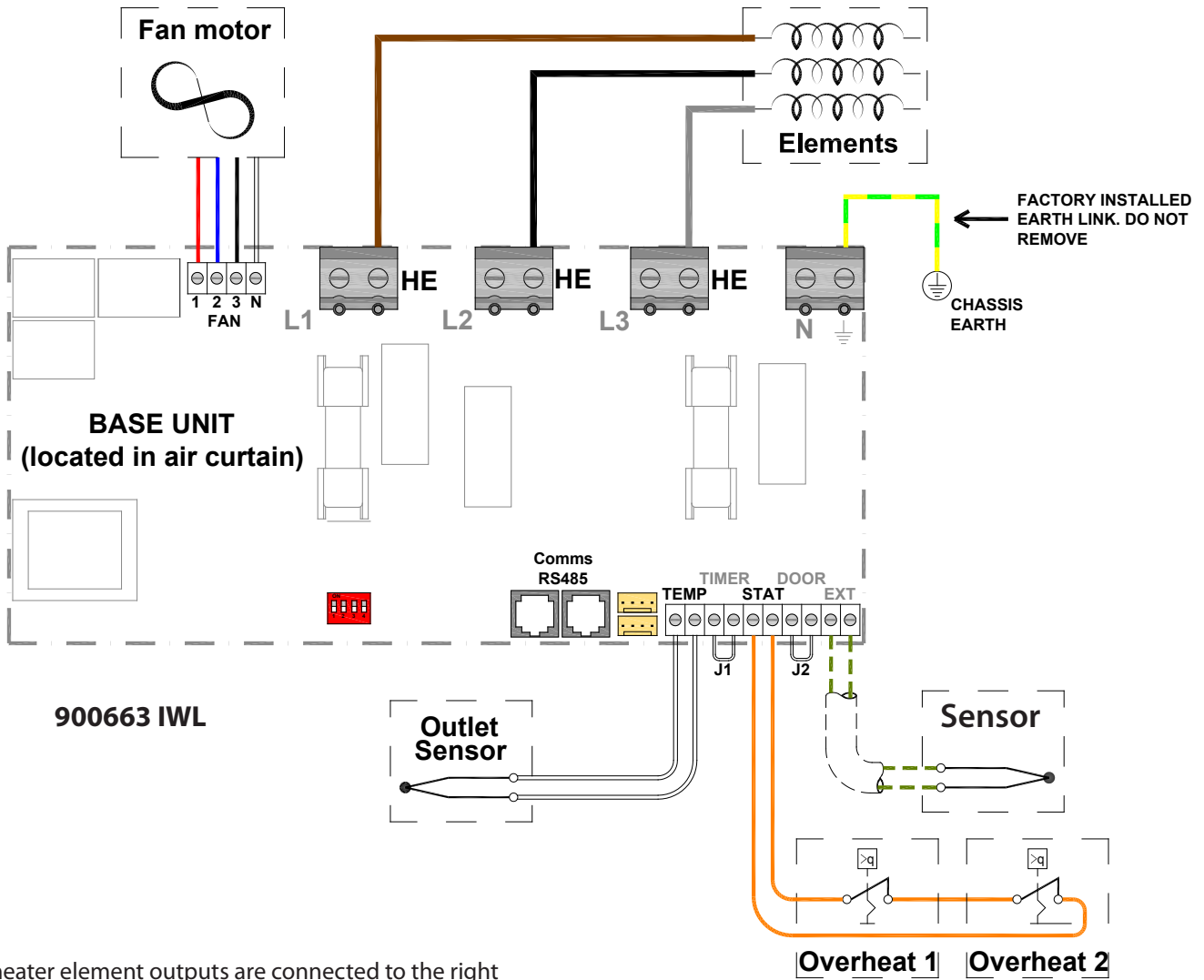

The heater element outputs are connected to the right hand side of three terminal blocks and are marked 'HE'. (See below).

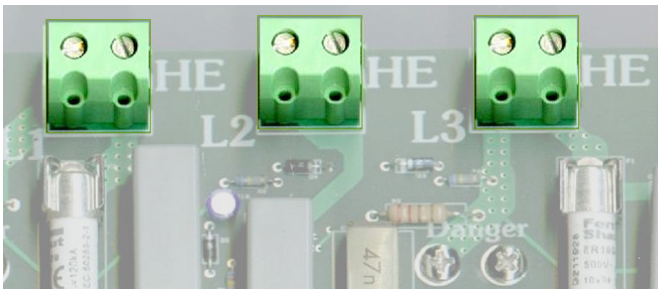

The fan output is connected to a 4 way terminal block marked 'N, 1, 2 and 3'.

The sensor input (air sensor) is connected to 2 terminals marked 'TEMP' on the base unit. The sensor is not polarity sensitive.

The external thermal trip (volt-free) is connected to 2 terminals marked 'STAT' on the base unit. The terminals are not polarity sensitive.

Terminal	Description	Cable
HE	Heating elements phase 1	10mm ² max
HE	Heating elements phase 2	
HE	Heating elements phase 3	
N	Neutral to fan	1.5mm ² max
Fan 1	Fan - low speed	
Fan 2	Fan - medium speed	
Fan 3	Fan - high speed	
Temp	Air sensor pair (non-polarised)	RJ45
Stat	Ext thermal trip pair, n.c. (volt-free)	
Ext	Option external sensor (supplied)	
Comms	Keypad/network connectors	

4.18 Network Wiring with SmartElec3 Control.

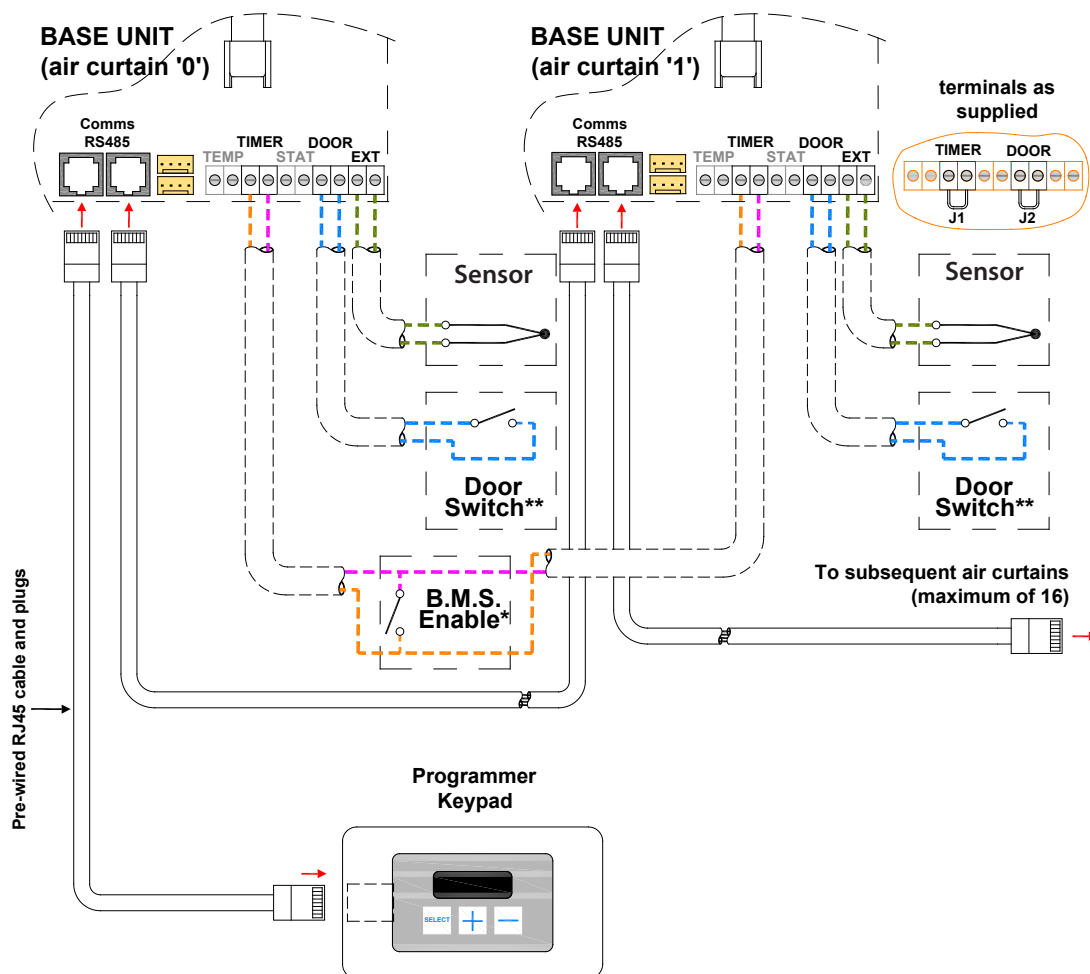

This diagram refers only to the wiring of 2 or more networked air curtains. (maximum 16 air curtains per control panel). For mains wiring refer to section 4 of this manual 'installer wiring details'.

The program panel is connected to the base unit in the air curtain via pre-wired RJ45 cable/plugs. These cables are available in 2, 10, 20, 30, 50 and 100m lengths. It is recommended that this control cable is run separately within its own trunking to avoid external interference.

 **Max cable run in any network must not exceed 110m in total including program panel cable.**

 **Note: All air curtains connected within the network system will operate under the settings of the single keypad.**

Any air curtain within the network can be connected with and respond to the following optional circuits:

* **External switch** (ie BMS enable) where required, to be volt free and wired in **PARALLEL** via normally open contacts to each terminal pair **'TIMER'**. (Contacts closed to enable). Only air curtain(s) wired this way will respond to the enable signal. Remove factory fitted jumpers J1. (**NOTE: terminals are polarity sensitive**)

** **Door switches** where required, to be volt free and wired to **INDIVIDUAL** base units via normally closed contacts to each terminal pair **'DOOR'**. (Contacts open to enable door mode). Only air curtain(s) wired this way will respond to the door mode. Remove factory fitted jumper J2. refer section 10.2.6.1 - Door link settings.

*** **Internal/external sensors**, where required, to be wired to **INDIVIDUAL** base units to each terminal pair **'EXT'**. Only air curtain(s) wired this way will respond to the sensor setting. If a sensor is fitted to more than one air curtain then the value is displayed as an average. refer section 10.2.6.4 - External temperature.

5. Installation Details.

5.1 Mounting

Airbloc units should be installed horizontally directly over the door opening. They are designed for discreet positioning in a suspended ceiling or bulkhead in the doorways of retail or commercial premises. The unit can also be mounted within an optional case for doorways with restricted space or no suspended ceiling or bulkhead.

! Care must be taken to allow complete free air movement into the inlet grilles of the unit to ensure correct working operation of the air curtain. The discharge opening should be as close to the top of the door as possible and to cover the entire door width.

Units can be mounted adjacent to each other to cover the full door opening across wider entrances.

5.2 Electrical Supply.

These units are suitable for connection to a 415 Volt, 50Hz 3 phase and neutral supply for Electrically heated 9-18kW models or 230/240 Volt 50 Hz single phase supply for Electrically heated 6kW, 9kW, Ambient and LPHW models.

Electrically heated models consume 6kW and 9kW at 230 volts and 9kW, 12kW & 18kW at 415 volts when switched to the full heat position depending on their model and capacity size.

The appliance should be connected to the supply via an appropriate switched fused double pole isolator having a contact separation of greater than 3mm. Test for correct operation and refit the cover.

For connection to the mains supply it will be necessary to open the hinged lid from the unit. The base unit is located on a base plate. It will be necessary to connect the mains supply and the lead from the remote key pad prior to refitting the cover. Wire in accordance to diagrams in section 4.1 to 4.4

For optional SmartElec3 controller, wire as shown in diagrams 4.15 to 4.18

! For safety reasons, a sound earth connection must always be made to the unit before it is put to use. The unit should be wired in accordance with IEE Regulations for the Electrical Equipment of Buildings.

5.3 Installation.

! It is the sole responsibility of the installer to ensure that

the points of attachment to the building are sound. Verification with the consultant/architect or owner of the building is recommended to ensure that a sound, mechanically stable installation can be achieved.

All attachments must be capable of supporting the weight of the product detailed in Section 3.

Step 1

Before fitting or wiring the air curtain, ensure casing faces as below and see general installation guidance notes.

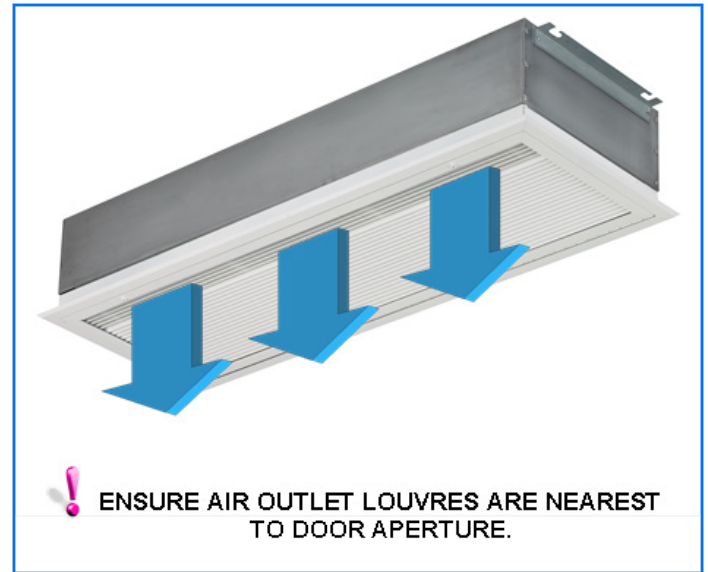

Step 2

Using a 4mm Allen key slacken the captive M6 Allen screws at the side of the grille.



Step 3

Access to the inside of the air curtain grille can be made. Open the grille. The grille is hinged to prevent the inner frame from dropping.

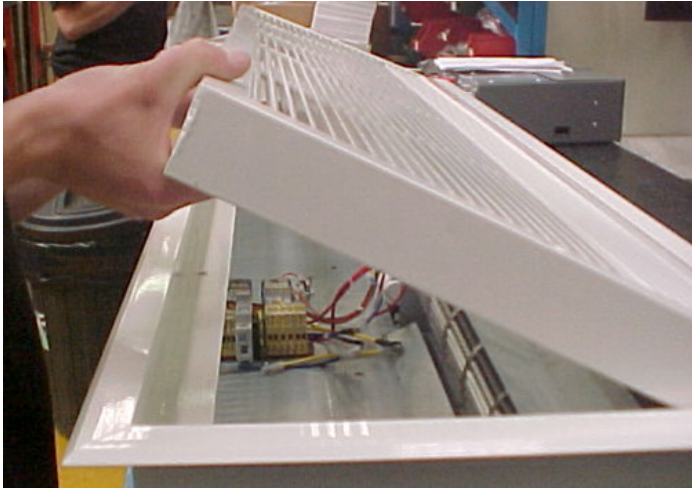

Step 4

The grille assembly can now be removed from the case to allow fitting of the product in the ceiling recess. Remove the screws from the outer frame to the top of the product case.

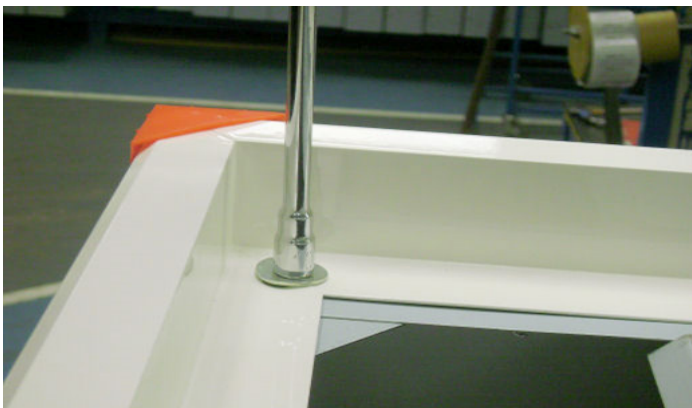

Step 5

Attachment of the air curtain to the ceiling structure is by means of the two brackets attached to the side of the air curtain. The brackets may be removed to assist in passing the air curtain through the recess then reattached when in-situ.



Step 6

Either drop rods or catenary wire (available from manufacturer) can be used to fasten the air curtain to the ceiling support structure.

 **Note** When using drop rods the casing mounting brackets are slotted and the mounting plates provided must be used on assembly.

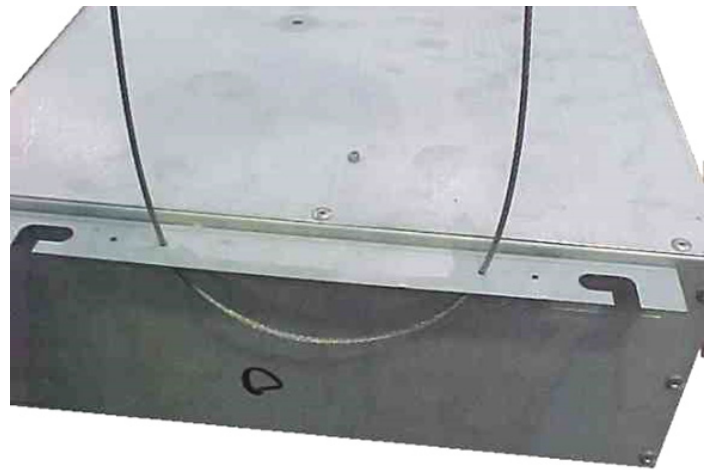
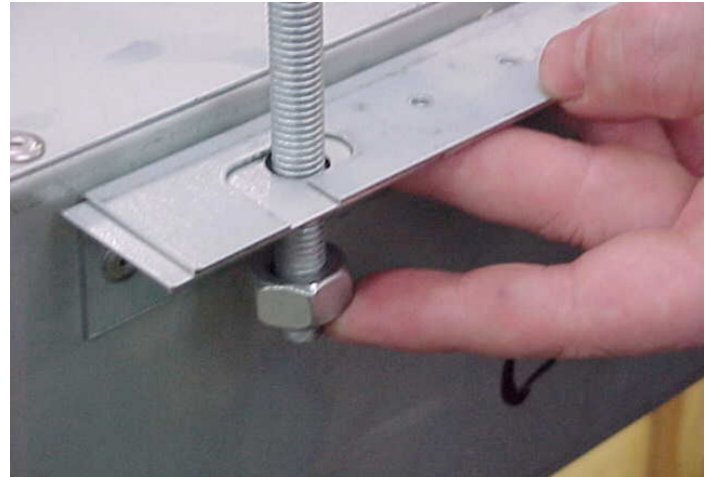

Step 7

The height between the ceiling face and the face of the air curtain case needs to be adjusted to approx 40mm to enable the grille assembly to fit flush with the ceiling. Adjust accordingly.



After fitting the product in the ceiling recess and adjusting the height to ensure that the grille sits flush to the ceiling (when re-fitted) take the grille assembly and refit using the screws removed during Step 5.

5.4 Program Keypad

The Electronic base unit is pre-installed inside the air curtain. All the external electrical connections are via screw terminals onto this unit.

The program keypad can either be installed on a standard double surface box, or recessed using a double flush conduit box.



Fig. 4. Surface mount dimensions.

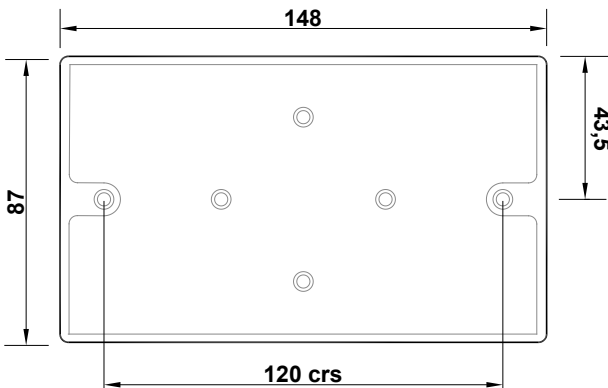

Alternatively, the program panel can be flush wall mounted with the addition of a suitable conduit box as shown in Fig 8.

 The distance between the base unit and the program panel can be up to 100m maximum.

Fig.5 Conduit box flush mounting



5.5 Option SmartElec3 Controller

The SmartElec3 base unit is pre-installed inside the air curtain. All the external electrical connections except for the keypad are via screw terminals onto this base unit.

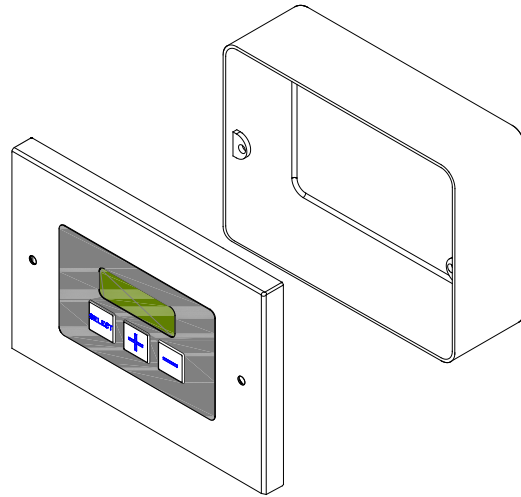
The SmartElec3 program panel is identical to the standard program panel and will auto detect a Smartcom base unit when plugged in.

5.6 Installation details - LPHW only

Fig. 6. Typical schematic of a 3 port valve system

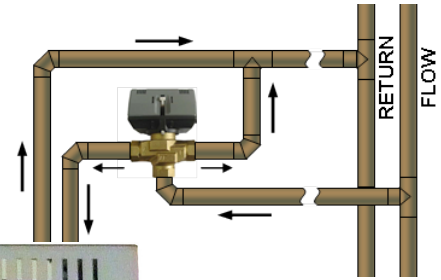
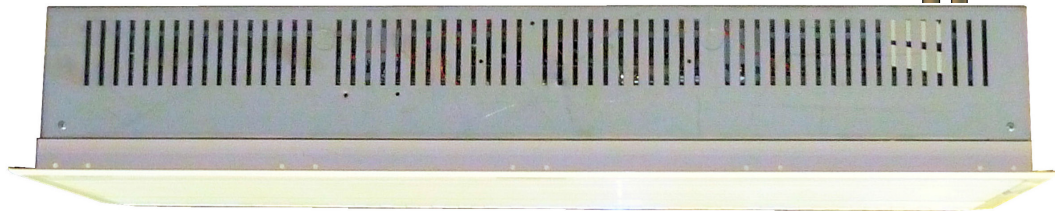

To avoid risk of transit damage to the flow and return connections, **ON LPHW STANDARD CAPACITY ONLY** the heating coil is provided loose inside the case together with the air deflector plate and side supports.

NOTE: HIGH CAPACITY LPHW COILS ARE PRE-FITTED.

To install, unpack the loose items and identify the two side supports as shown below and fit to the inner side of the case using the screws provided.

Note The side supports are handed.

The coils **can be handed for right or left hand** exit by turning the coil through 180°. Prior to installation decide if you require left hand or right hand exit of the flow and return pipes from the product and then fix the coil in position using the screws provided.

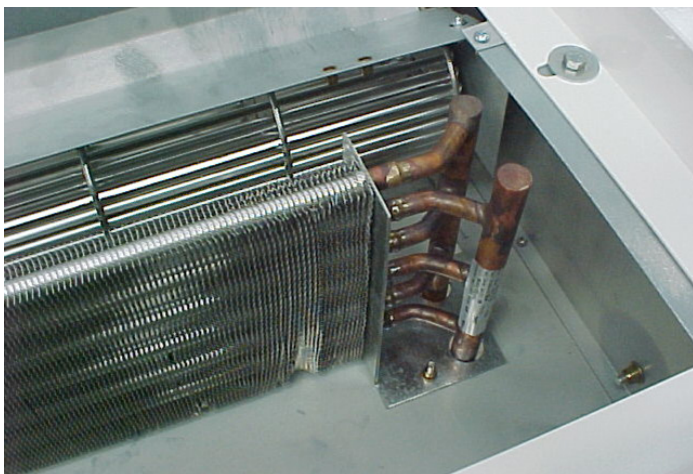

After fitting the coil and side supports fit the air deflector plate to the side supports and rotor cut-off plate using the screws provided.

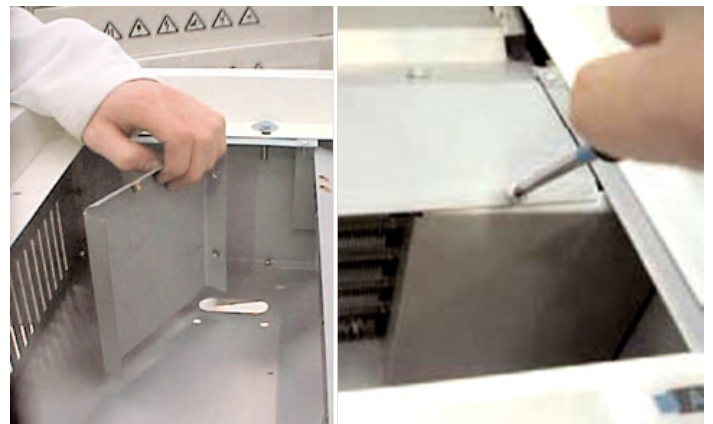

The LPHW copper tubing connections are as shown in fig.12 below and are 15mm outside diameter. Ensure correct water seal fittings are used. We recommend the use of a suitable water mains isolation valve to ease any maintenance.

Fig.12 LPHW connections.

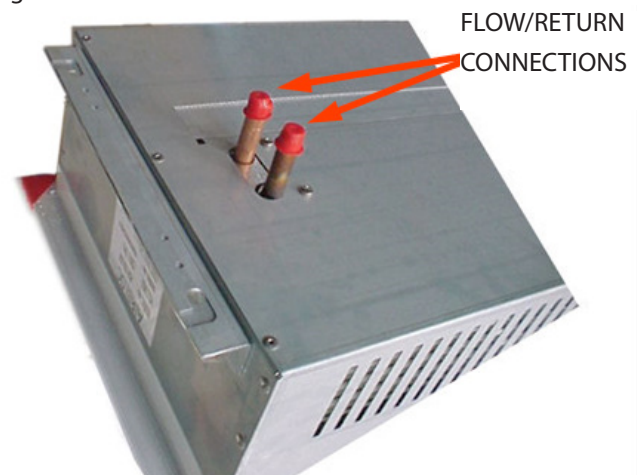

Carefully close the grille and refit the fixing screw.

Test product as shown in the User Instructions.

5.6.1 Three Port Valve

An optional 3 port valve (supplied by others) can be used on the flow and return pipes to divert the hot water from the unit when not in use.

The valve must be fitted in accordance with the manufacturers instructions.

When used in conjunction with the LPHW programmer, the 3 port valve can be wired into the base unit to open the valve when heat is selected (see section 4.5). This valve must operate on 0-10v DC.



Note: This option can not operate with a SmartElec unit.

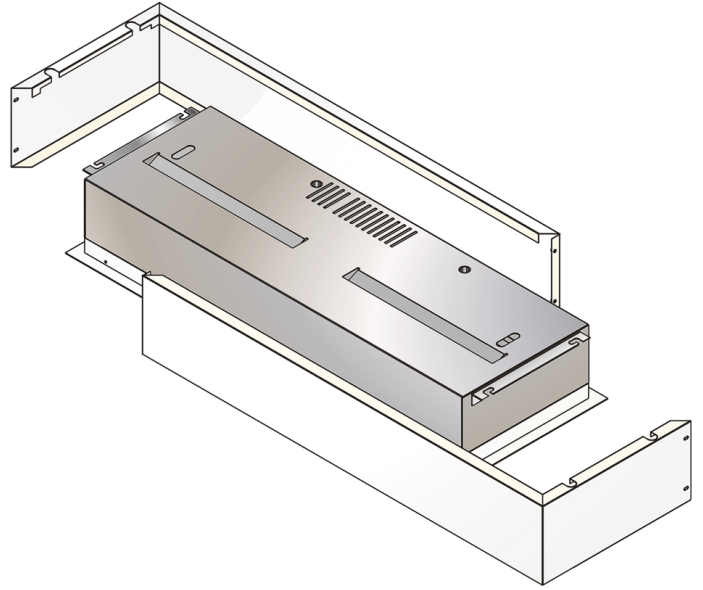

5.7 Installation wiring

With the grille door open, connect the electrical supply and program panel interconnecting wiring/factory supplied cables to the relevant terminals on the controller base unit.

Connect any interconnecting wiring/factory supplied cables to the programme panel.

Connect any optional wiring as required.

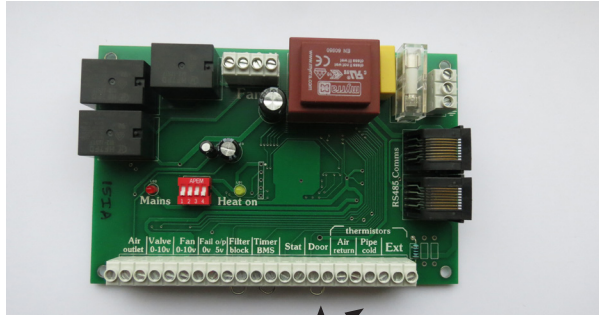

Customer wiring terminals.

For full details see wiring diagrams in section 4. Ensure the correct diagram is used based on the information from the air curtain data plate and optional manufactures information.

Install the ACR unit using drop rods as previously described.

The sides of the case simply 'wrap' around the exposed body of the air curtain fixing at two edges (all four edges in the case of the 2000mm), with screws.

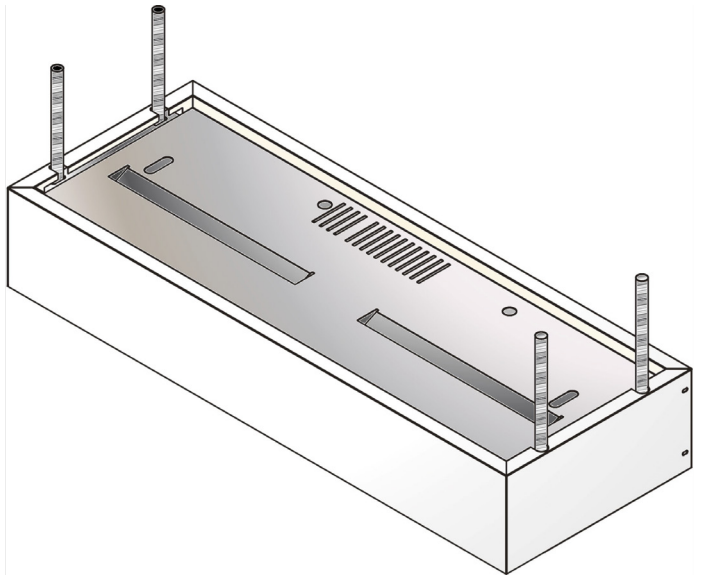

5.8 Installation details - optional Case

The ACR unit can also be mounted within an optional pre-coated outer case for use in doorways with restricted space or areas with no suspended ceiling or bulkhead.

The cases either come in two halves (as shown) for the 1000mm and 1500mm or four individual sides for the 2000mm.



WARNING:
THIS AIR CURTAIN SHOULD NOT BE INSTALLED WHERE THERE IS A CORROSIVE ATMOSPHERE.

6. Service & Maintenance.

 ALWAYS ENSURE THAT THE EXTERNAL MAINS ELECTRICITY SUPPLY IS SWITCHED OFF BEFORE COMMENCING ANY MAINTENANCE ON THIS HEATER

 To obtain the best results from the heater, it is essential to avoid the accumulation of dust and dirt within the unit on the air inlet and discharge grilles. For this reason regular cleaning is necessary, paying particular attention to the removal of dirt build up on the rotor blades.

Cleaning of the fan is best carried out with a soft brush.

A single drop of light oil should be applied to the motor bearing from time to time.

The product should be serviced annually. Servicing shall be undertaken by a competent person. Airbloc offer a service facility, call 01384 489700.

Step 1

Using a 4mm Allen key slacken the captive M6 Allen screws at the side of the grille.



Step 2

Open the grille. The grille is hinged to prevent the inner frame from dropping. Access to the inside of the air curtain grille can be made.

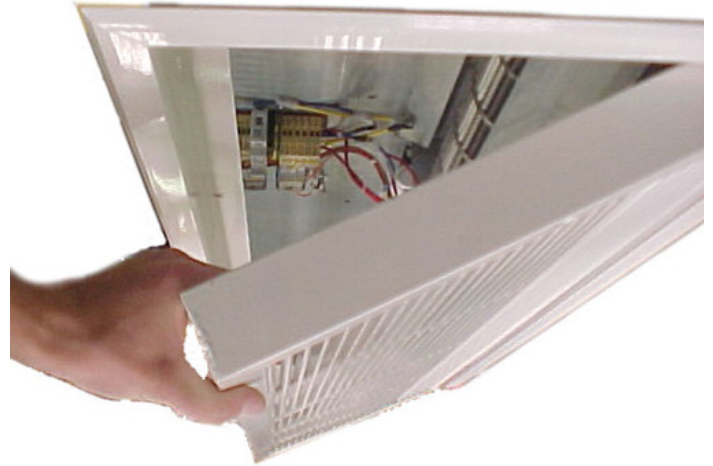

Step 3

With a soft brush clean away any dust from the motor and elements.





Check all connections and components for soundness or signs of deterioration and replace as necessary.

Re-assemble and test.

7. Spare Parts.

 Note Any spare part components that are not approved by Nortek Global HVAC (UK) LTD could invalidate the approval of the appliance and invalidate the warranty.



7.1 General

Item	Desc.	ACR1000SE06/ ACR1000SE09/ ACR1000SW9/ ACR1000SA	ACR1500SE06/ ACR1500SE12/ ACR1500SW12/ ACR1500SA	ACR2000SE09/ ACR2000SE18/ ACR2000SW18/ ACR2000SA	ACR1200HE12/ ACR1200HW12/ ACR1200HA	ACR1800HE18/ ACR1800HW18/ ACR1800HA
	Motor	100003		100012	100535	
	Rotor Left Hand*	100001	100006	100010	100539	100540
	Rotor Right Hand*	100002	100007	100011	100536	100537
	Thermal Cut Out (where reqd)	900001				

* Right hand & left hand when viewed from outside the building looking into the door opening.



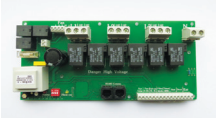





7.2 Standard Controller

 Due to the nature of it's construction, it is not advisable to repair damaged electronic components on either the base unit or programmer (keypad).

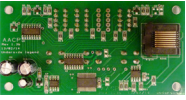
	Program Panel	108221-RJ45
	Base Unit	STDELECBU45 (electric) LPHWBU45 (LPHW+ambient)
	Outside Air Sensor	SC-OS

7.3 SmartElec3 Controller

 Due to the nature of its construction, it is not advisable to repair damaged electronic components on either the SELEC3BU45 base unit or AC-ACRRP45 programmer

Item	Desc.	All models	Item	Desc.	All models
	Program Panel	108221-RJ45		Control Fuse	900473
	Panel P.C.B.	AC-ACRRP45		Outdoor Sensor	SC/OS
	Base Unit	SELEC3BU45		Data cable c/w plugs	2M RJ45-CABLE-2 10M RJ45-CABLE-10 20M RJ45-CABLE-20 30M RJ45-CABLE-30 50M RJ45-CABLE-50 100M RJ45-CABLE-100
	Heat Sensor	SELEC2HS			
	Fuse	900471			

7.4 Heat Mediums

Electric Element

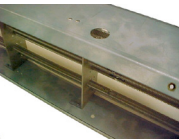
Item	Rating	6kW	9kW	12kW	18kW
	SE 1Pha	101565/107817	107818	-	-
	length	1.0m/1.5m	2.0m	-	-
	HE 3Pha	-	100004	100008	100013
	length	-	1.0m	1.5m	2.0m
	HE 3Pha	-	-	100526	100527
	length	-	-	1.0m	1.5m

LPHW coil

Item	Rating	9kW	12kW	18kW
	SE	100197	101280	100199
	length	1.0m	1.5m	2.0
	HE		103680	103607
	length		1.0m	1.5m

8. Fault Finding.

8.1 General

If the air curtain does not operate after running through the detail provided in Section 10, then a suitably competent service engineer should be called to identify the nature of the fault.

 *Note The manufacturer operates a service function from the address provided in these instructions.*

All air curtains are fitted with fuse protection and motor thermal protection.

Other faults in relation to the element, motor and wiring should be identified using conventional fault finding techniques.

In the event that electrical components are replaced, please ensure that electrical safety checks in accordance with the regulations in force in the country of use are undertaken.

8.2 Electrically heated units only.

For the service engineer, please note that there are two thermal cut-outs incorporated in the air curtain which, if tripped, need to be manually reset. The cut-outs are located in the airflow near to the elements on the left and right.

Re-setting the thermal cut-out may help to identify the nature of the fault however we do not recommend a re-set without a thorough investigation into why the cut-out operated.

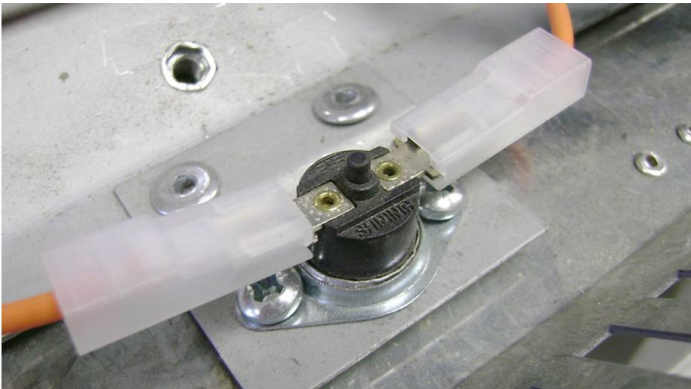



Fig. 13. Thermal Cut-out

8.3 Standard Controller.



For fault codes refer to SmartElec3 fault table on next page.



8.4 SmartElec3 Controllers.

The SmartElec3 control raises an alarm if any of its inputs are outside their normal working scope. Alarms are displayed on the program panel as a code with a prefix "E" . The first number represents the air curtain address. See chart over.

As the alarms are mutually exclusive, the first alarm code displayed on the program panel will stay on until the fault has

been cleared.

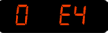
Apart from the communication failure alarm  which could be due to a broken connection of the data link and air curtain not found alarm,  which could be due to incorrect addressing, all other alarms will cause the base unit to switch off the heater output.

The SmartElec3 base unit is protected from any short circuit on the air sensor  or heat sink sensor  as the error will cause the temperature to rise and trigger over temperature alarm. 

There are five basic checks to perform should 'X--'  appear on the program panel display. These are as follows:

1: Continuity: Use a multimeter to check continuity between each end of all four cores at the plugs

2: Short circuit: Use a multimeter to check that there are no short circuits between any of the four cores.

N.B. This test should be done with both ends of the cable disconnected to avoid false readings.



3: Plugs: Check that the plugs are firmly seated on the circuit board in both the program panel and on the base unit.

4: Addressing: (network versions only). If two or more air curtains are networked, check that each base unit has a unique address as described in section 10.2.8.

5: Network cables: Ensure that the total run of all cables in the network does not exceed 110m including the cable to the program panel.



If a panel has never before been run, it automatically starts in engineer's mode when first powered-up. To exit this mode, press and hold the  button.

Alternatively, the engineer's mode automatically self-clears after approximately 10 minutes of non-activity on the buttons.

The system can be reset by powering-up the panel whilst holding down both the  and  buttons.

The display shows the 'start' pattern but then goes blank.

Release the buttons. The display resumes and the system finds only those air curtains which are actually connected and working.

If  appears on the display, press and hold the  button for a few seconds then release. The display will then return to the normal mode.

8.4.1 SmartElec3/Standard Fault Codes

= Air curtain address

#_#, #E1, #E2, #E5 and #E6 codes also apply to **standard controller**.

Code	Description	Symptom	Possible Cause	Remedy
#_#	Communications failure	No control on unit	Bad data cable connection Damaged cable	Check data cables and plugs Replace damaged cable
# E1	Air sensor failed	Fan operating, no heat	Air sensor cable disconnected Air sensor broken	Check cable Replace air sensor
# E2	Air sensor temp too high	Fan operating, no heat	High ambient air temperature Incorrect impeller rotation Motor failure	Check ventilation Check rotation of impeller Check motor, replace if necessary
# E3	Heatsink too hot	Fan operating, no heat	High ambient air temp/faulty base unit	Replace SmartElec base unit
# E4	Heatsink sensor failure	Fan operating, no heat	Heatsink sensor wiring disconnected/faulty Heatsink sensor faulty	Check wiring Replace SmartElec base unit
# E5	Ext. temp sensor failure	Unit runs but no external temperature control	External temperature sensor faulty	Repair faulty wiring Replace faulty sensor
# E6	Overheat stat open circuit	Fan operating, no heat	Overheat stat open circuit	Replace overheat thermostat

8.4.2 SmartElec3 base unit LED indicator location/function

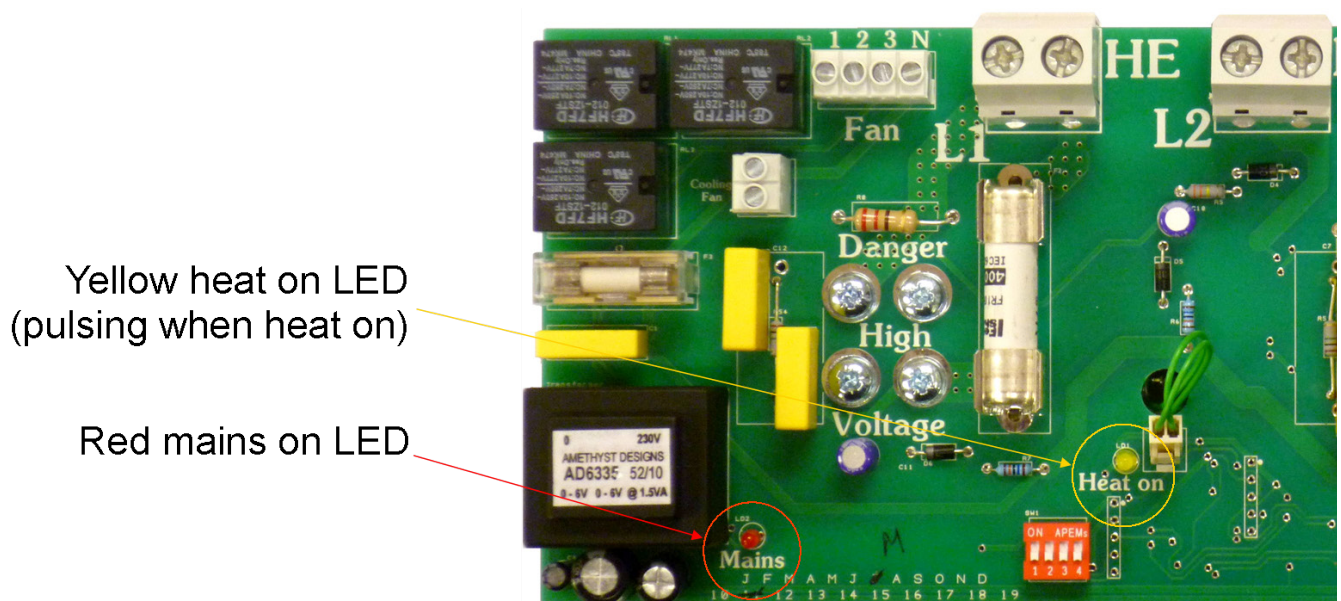

Note: Standard controller LEDs have the same function and are in similar positions on the PCB.

9. Parts Replacement.



Warning

Ensure electrical power is isolated from the product.

For access follow steps 1 - 4 as stated in Section 6

9.1 Electrical element replacement SE.

Step 1

Using a 4mm Allen key slacken the M6 Allen screws at the side of the grille. Access to the inside of the air curtain grille can be made. Open the grille. The grille is hinged to prevent the inner frame from dropping.

Step 2

Disconnect element wires and if necessary remove cut-off plate fixing screws.

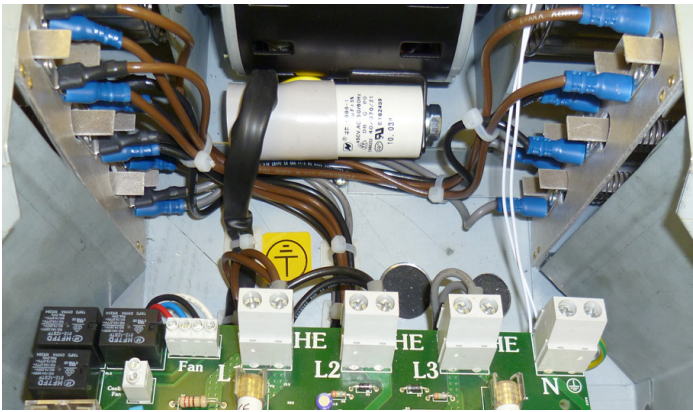

Step 3

Remove element top fixing screws. Locate and remove element fixing screws by inserting a screwdriver through the hole indicated below.



Step 4

Lift out element cartridge, replace as required.

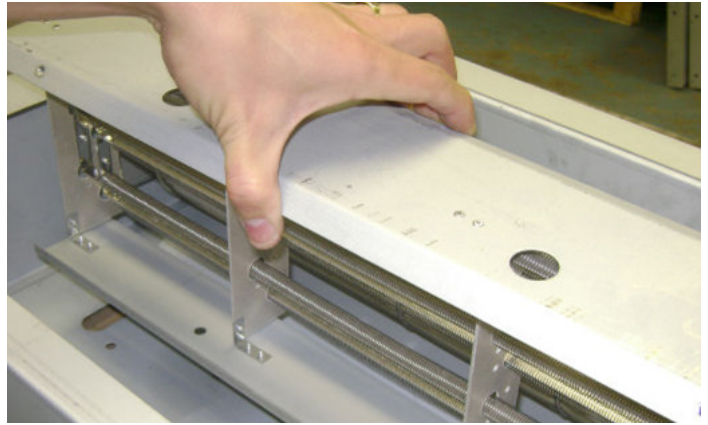

9.2 Electrical element replacement HE.

Step 1

Using a 4mm Allen key slacken screws securing the grille. Remove 4 screws securing the top of the case and remove. Slacken two hinging bolts on both ends. Remove three bolts securing the access plate. Carefully hinge down the access plate.



Note: Take the weight as access plate swings down.

Step 2

Carefully remove connections to the elements, noting wiring configuration.

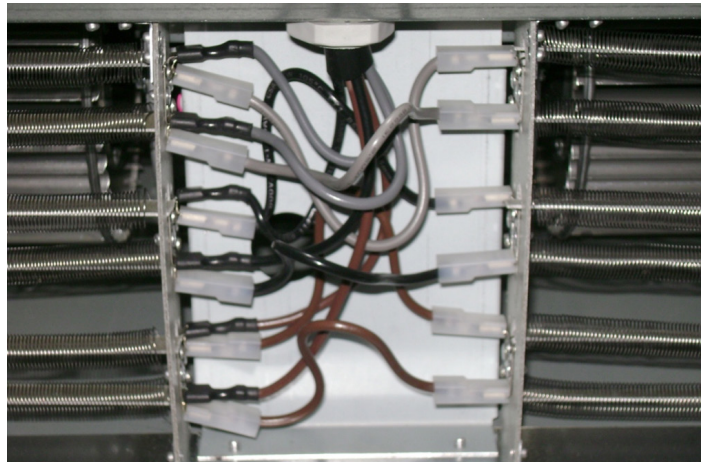

Step 3

Remove two bolts securing elements.

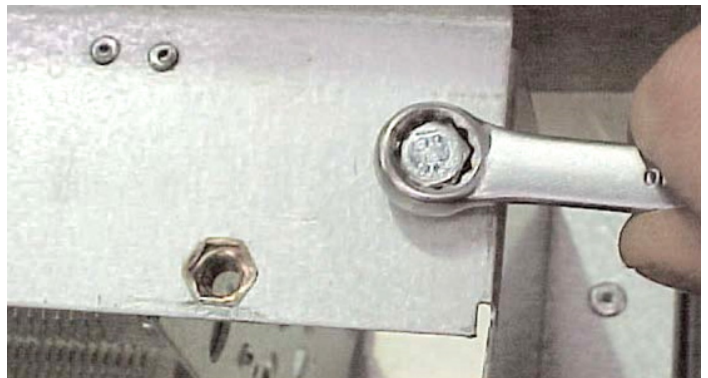

Step 4

Lift out element cartridge, replace as required.

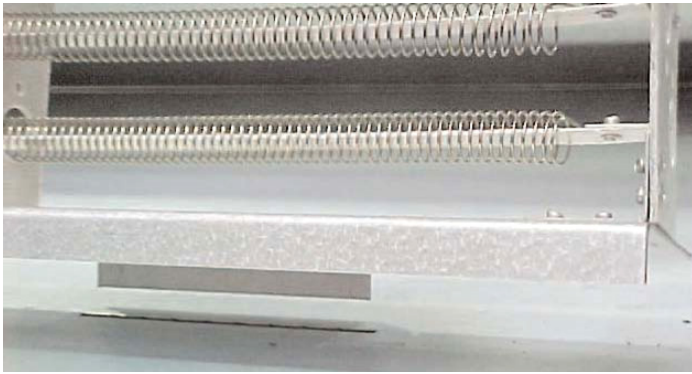

9.3 Rotor and motor replacement SE

Step 1

Using a 4mm Allen key slacken the M6 Allen screws at the side of the grille. Access to the inside of the air curtain grille can be made. Open the grille. The grille is hinged to prevent the inner frame from dropping.

Step 2

Remove fastenings securing the motor end of the deflector plate, including the single side screw (arrowed).

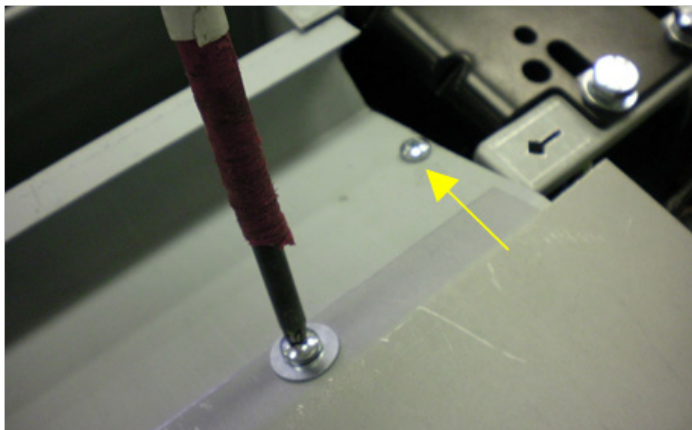

Step 3

Remove the four screws securing the rotor support bracket and the opposite end of the deflector plate. Remove plate.

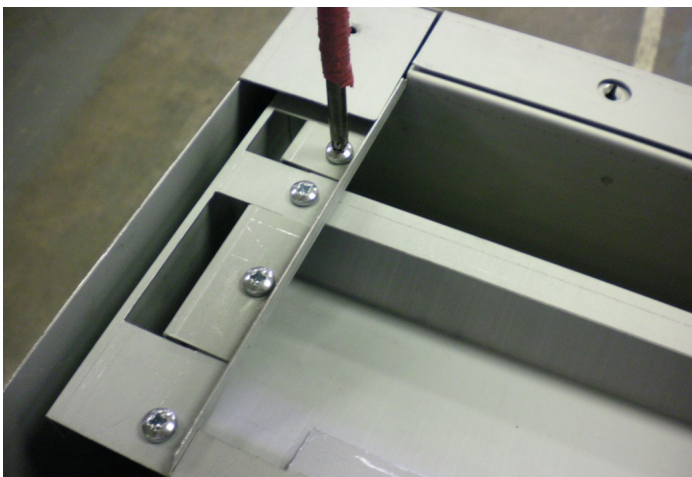

Step 4

Using a 2.5mm Allen key, slacken the rotor hub grub screw.



Note: when refitting ensure that the grub screw bears on the flat of the motor shaft.

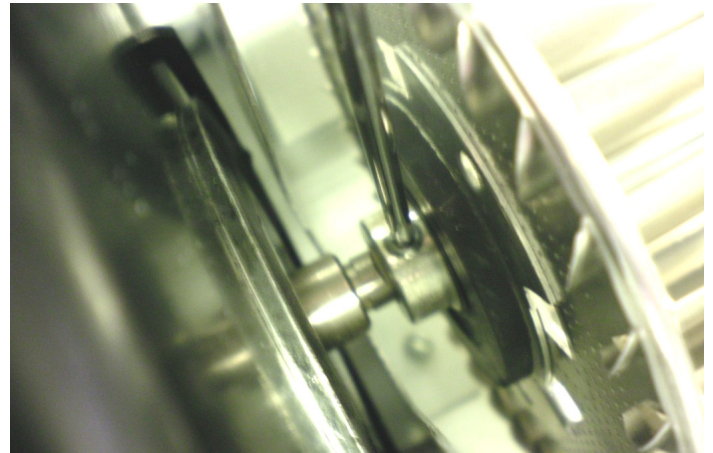

Step 5

Push the rotor support bracket away from the rotor to release the rotor bearing.

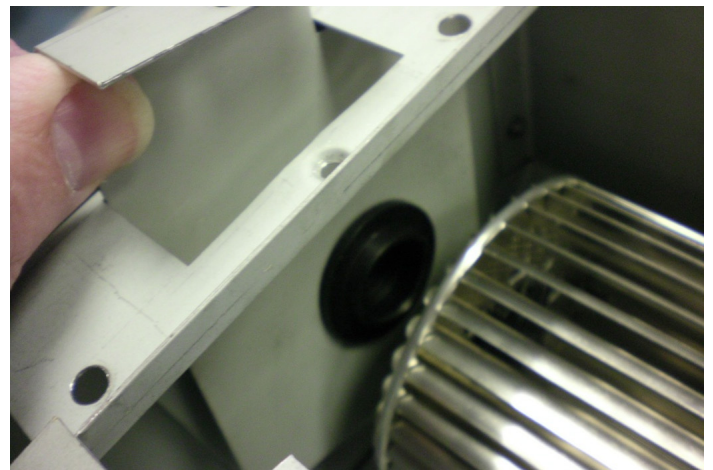

Step 6

Lift the rotor clear of the motor shaft then remove it from the air curtain.

Step 7

Disconnect fan motor cables from the terminals arrowed including the earth which is bolted to the chassis. (SmartElec shown over).

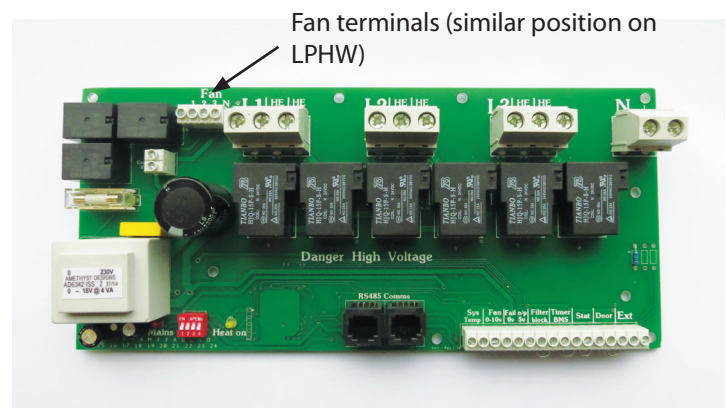

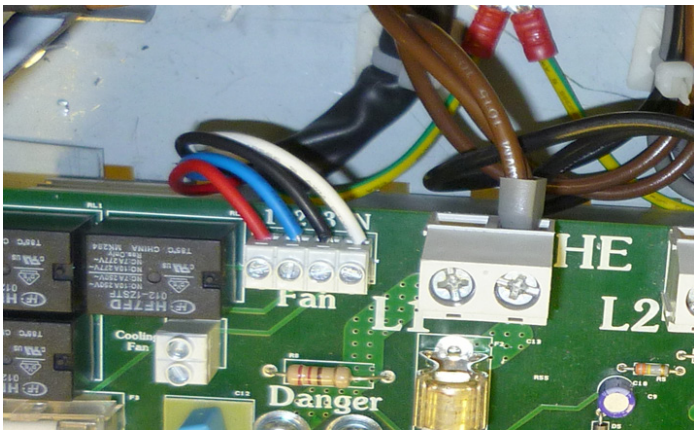

Step 8

Remove the four 10mm bolts securing the motor to its bracket.

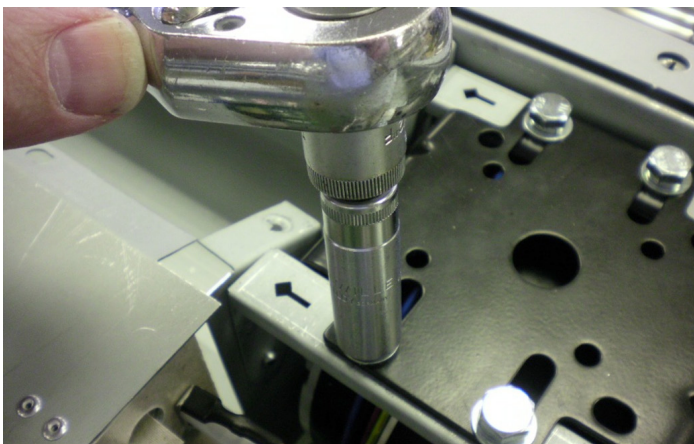

Step 9

Swing the movable bracket clear and remove the motor.

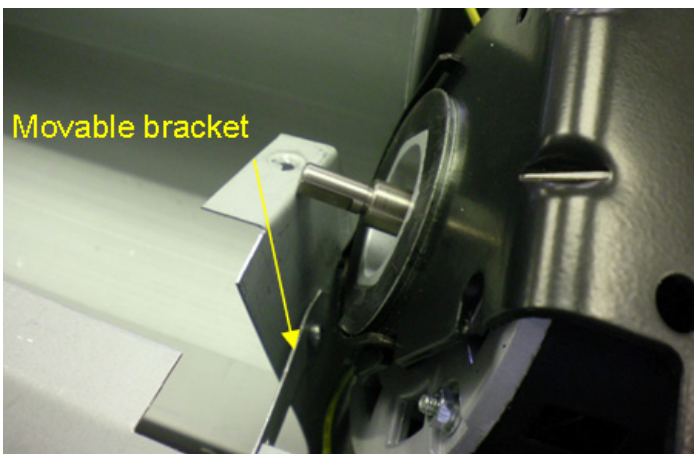

9.4 Rotor and motor replacement HE

Step 1

Using a pozidrive screwdriver undo screws securing the grille and remove.

Remove 4 screws securing the top of the case and remove. Slacken two hinging bolts on both ends.

Remove three bolts securing the access plate.

Carefully hinge down the access plate.

 *Note Take the weight as access plate swings down.*

Step 2

Remove 6 screws securing access panel and carefully remove panel.



Step 3

Remove 8 bolts securing wheel assembly.



Step 4

Turn retaining latch to release chassis.



Step 5

Holding handle, carefully pull motor and air wheel assembly forward.



Step 6

Remove screw securing rotor bearing plate.
Repeat for opposite side.

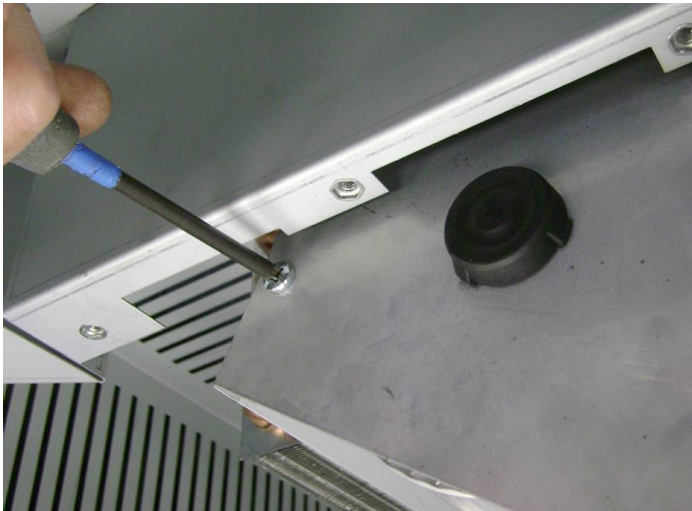

Step 7

Slacken grub screw securing rotors to the motor shaft, remove rotor.
Repeat for opposite rotor.

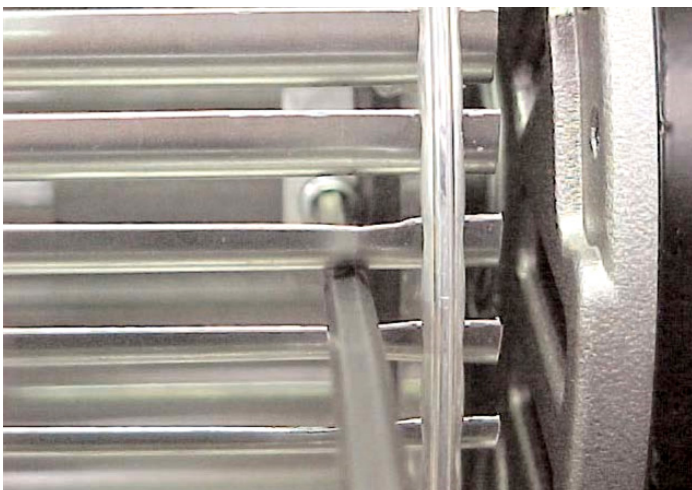

Step 8

Disconnect the wires from the motor to the controller base unit.

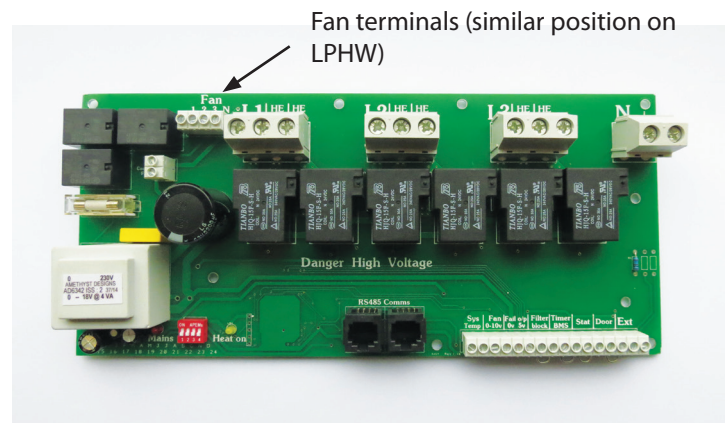

Step 9

Remove the bolts securing the motor to the chassis.

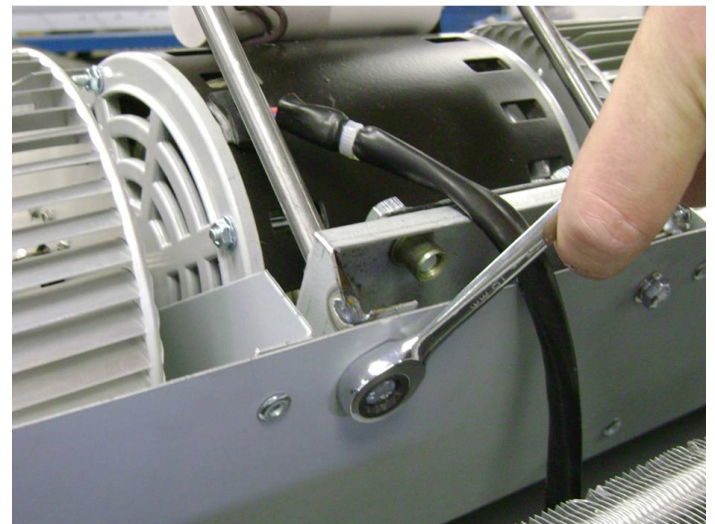

Remove motor from air curtain.

Replace motor in reverse order. Carefully close the grille and refit the fixing screw.

Test product as shown in the User Instructions.

9.5 LPHW coil replacement.

Step 1

Using a 4mm Allen key slacken screws securing the grille.
Remove 4 screws securing the top of the case and remove.
Slacken two hinging bolts on both ends.
Remove three bolts securing the access plate.
Carefully hinge down the access plate.

 *Note: Take the weight as access plate swings down.*

Step 2

Disconnect flow/return connections with appropriate tools.

**Step 3**

Remove the air deflector plate and the side support plates, retaining the screws.

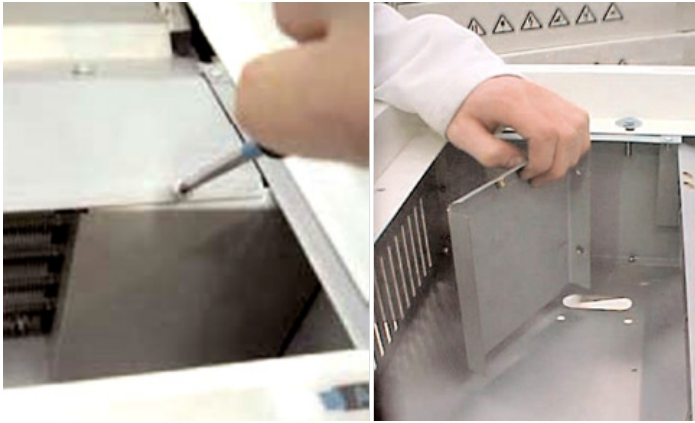
**Step 4**

Remove coil fixing screws from the outside of the air curtain body.

Step 5

Withdraw the coil.

Replace LPHW coil in reverse order.

10. User Instructions.

10.1 Standard Controller (electrically heated)



10.1.1 Keypad Buttons



The **SELECT** button will allow you to navigate.

The **+** button will allow you to increase the setting.

The **-** button will allow you to decrease the setting.

10.1.2 Operation

On first power up, the display will show and have the following default settings:



- F. 0 (no fan)
- H. 0 (no heat)
- 16 (°C. Heat set point)

If no air curtains are detected the display will show:



Note: Subsequent power ups will retain any entered settings in the display internal memory.

In normal operation the display will show for example:



'1' denotes the AIR CURTAIN ADDRESS, and '27' the current outlet temperature.

If the display is set to 'H1' (half heat) then the display unit will show:



The 'dot' after the air curtain number denotes heat setting 1.

If the display is set to 'H2' (full heat) then the display unit will show:



The 'dot' after the temperature number denotes heat setting 2.

If an external temperature sensor is fitted then the display will also show:



The small 'zero' shows a sensor detected and it's current temperature reading.

10.1.3 Standard Settings

Press the **SELECT** button. This will cause the display to brighten and display air curtain number and it's fan speed eg.



Press the **+** or **-** buttons to increase/decrease the desired setting between F0, 1, 2, or 3.

Pressing the **SELECT** button again will display the air curtain number and it's heat setting eg.



Press the **+** or **-** buttons to increase/decrease the desired setting between H0, 1, or 2.

Pressing the **SELECT** button again will loop back to start if only one air curtain is connected to the display unit. If there is more than one connected the display unit will then show the settings for the next air curtain in the network and so on.

10.1.4 Engineers Settings

To turn on the engineers settings press and hold the **+** button until the display goes blank then press the **SELECT** button. The display unit will now display 'Eng' briefly.



Press the or buttons to increase/decrease the desired setting between C0, or 1-7 (see table below).

If the air curtain is set to eg.:

This will disappear after a period of 10 minutes of inactivity on the keypad.

On pressing the button the display unit now works in the same way as standard for the fan and heat settings, but then an adjustable control temperature setting appears (if external sensor fitted).



This denotes that air curtain '1' is set to be the master for door and BMS interlocks. If interrogated all other air curtains will then display eg.



This control works by reading the temperature at the sensor and comparing it to the set point. The temperature is then controlled by automatically switching the controller outputs between H0, H1, and H2, thus maintaining reasonable heat control.



This denotes a unit that is not the master.

Pressing the button again advances to the door link settings.

10.1.4.1 Door Link Settings

Two settings are available for use when the door link circuit terminals are open circuit (PCB link removed). The first of these is displayed as:



'1' is the air curtain address and 'd2' denotes fan speed 2.

Press the or buttons to increase/decrease the desired setting between d0, 1, 2, or 3.

The second is displayed as:



'1' is the air curtain address and 't1' denotes heat setting 1.

Press the or buttons to increase/decrease the desired setting between t0, 1 or 2.

Pressing the button again advances to the link group interlock settings.

10.1.4.2 Link-Group Interlock

If there is more than one air curtain connected to the display then there are two sets of interlocks available to enable a single air curtain in a group to be the 'master' controller based on links used.



'1' is the air curtain address and 'C0' is the default setting (no interlock set)

'C' interlocks setting	Effect
1	Timer/BMS interlock
2	Door interlock
4	Stat interlock
'L' interlocks setting	Effect
1	Not used
2	Not used
4	Blocked filter interlock

To set more than one interlock, add the appropriate numbers together, eg. 'C3' above works on timer and door interlocks.



If a controller is not the master, all three interlock links must be in place.

10.1.4.3 All Controllers

This setting can be accessed from the engineers settings whilst the external temperature indication is showing (see previous page). This is displayed as:





This allows a single group of settings to be copied to all controllers in a network. Individual settings can still be used at a later date if required.

Quick Options

1. Immediate turn off:

Press and hold the button for two seconds, the display will go blank then the air curtain(s) will turn off.

2. Re-scan/Engineers mode:

Press and hold the  button for two seconds, the display will go blank, then press . The display will show the controller type in the first digit and the number of air curtains in the fourth digit. Release both buttons and then press any button to continue, the panel is now in Engineers mode.

3. Turn on Engineers mode:

Press and hold the  button for two seconds, the display will go blank, then press  the display will show 'Eng', Release both buttons.

4. Turn off Engineers mode:

Press and hold the  button for two seconds, the display will go blank, then release.

5. Air curtain addressing: See section 10.2.8

10.2 LPHW/Ambient Controller

10.2.1 Keypad Buttons



The  button will allow you to navigate.

The  button will allow you to increase the setting.

The  button will allow you to decrease the setting.

10.2.2 Operation

On first power up, the display will show  and have the following default settings:

- F.0 (no fan)
- H.0 (no heat)
- 16 (°C. Heat set point)

If no air curtains are detected the display will show:



 *Note: Subsequent power ups will retain any entered settings in the display internal memory.*

In normal operation the display will show for example:



'1' denotes the air curtain address, and '27' the current outlet temperature.

If the display is delivering power then the display will show:



If an external temperature sensor is fitted then the display will also show:



10.2.3 Standard Settings

Press the  button. This will cause the display to brighten and display air curtain number and it's set point temperature eg:





Pressing the  button again will show the fan settings eg:



Pressing the  button again will show the heat settings eg:





10.2.4 Engineers Settings

To turn on the engineers settings press and hold the  button until the display goes blank, then press the  button. The display unit will now display 'Eng' briefly.



This will disappear after a period of 10 minutes of inactivity on the keypad.

On pressing the  button again the display unit now works in the same way as standard for the fan and heat settings. The next press of  will advance to the 'door link' settings if only one air curtain is connected, or 'link group interlocks' if more than one air curtain is connected.

10.2.4.1 Door Link Settings

Two settings are available for use when the door link circuit terminals are open circuit (PCB link removed). The first of these

is displayed as:



'1' is the air curtain address and 'd2' denotes fan speed 2.

Press the **+** or **-** buttons to increase/decrease the desired setting between d0, 1, 2, or 3.

The second is displayed as:



'1' is the air curtain address and 't1' denotes heat setting 1.

Press the **+** or **-** buttons to increase/decrease the desired setting between t0, 1, 2, 3 etc. where 0 is heat off

- 1 is 5°C
- 2 is 10°C
- 3 is 15°C

Pressing the **SELECT** button again advances to the link group interlock settings.

10.2.4.2 Link-Group Interlock

If there is more than one air curtain connected to the display then there are two sets of interlocks available to enable a single air curtain in a group to be the 'master' controller based on links used.



'1' is the air curtain address and 'C0' is the default setting (no interlock set)

Press the **+** or **-** buttons to increase/decrease the desired setting between C0, or 1-7 (see table below).

If the air curtain is set to eg.:



This denotes that air curtain '1' is set to be the master for door and BMS interlocks. If interrogated all other air curtains will then display eg.



This denotes a unit that is not the master.

To set more than one interlock, add the appropriate numbers together, eg. 'C3' above works on timer and door interlocks.



If a controller is not the master, all three interlock links must be in place.

10.2.4.3 All controllers

'C' interlocks setting	Effect
1	Timer/BMS interlock
2	Door interlock
4	Stat interlock

'L' interlocks setting	Effect
1	Not used
2	Not used
4	Blocked filter interlock

This setting can be accessed from the engineers settings whilst the external temperature indication is showing (see previous page). This is displayed as:



This allows a single group of settings to be copied to all controllers in a network. Individual settings can still be used at a later date if required.

10.2.4.4 External Temperature

Display will show eg:



This will only be displayed if there is an external sensor fitted, and shows the external sensor temperature set point. Once set the air curtain will turn off when it reaches the set point. The temperature then has to drop 3°C before the air curtain turns back on again.

10.2.4.5 External Temperature Offset

Display will show eg:

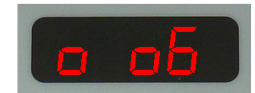

If the outside temperature falls to zero°C, this setting shows the temperature offset above zero. This will temporarily raise the temperature setting 6°C above the actual set point. Possible settings are 0-9 where 0 is off if this function is not required.

10.2.4.6 Temperature Limits

The next two displays eg:



These show the permissible upper and lower limits for setting the external temperature sensor set point. This is useful for allowing the end user limited control over this setting. The maximum (default 35°C) may be set anywhere between the current minimum and 50°C, and the minimum (default 16°C) may be set anywhere between 3°C and the current maximum.

10.2.4.7 Air Return and Pipe Cold Sensors

The readings from these sensors is not shown on the display, and unless both are connected there is no effect on the heating control. When both sensors are connected they operate as follows: When the heating is first turned on the temperature readings from the sensors should be close together, two minutes later there should be a difference of at least 2°C. If there is no difference then the controller assumes that there is no flow then turns the heating off.

10.3 Option SmartElec3 Controller

10.3.1 Keypad buttons

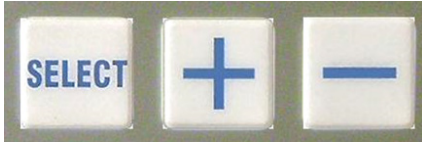

The buttons have the following functions:

 Press the select button to allow navigation.

 Press the + button to increase a setting.

 Press the - button to decrease a setting.

10.3.2 Operation

10.3.2.1 Normal mode displays

 First power up

 No air curtains found

 Curtain address and temperature set point

10.3.2.2 Normal Operation

During normal operation mode the display is dimmed.

Pressing the  button, will put the panel into active mode. If

During normal operation the unit will display for example:

 where '0' is the curtain address, and '25' the temperature measured for the unit.

 Where multiple air curtains exist in a network, the display scrolls through each unit in turn, changing approximately once every second.

If the air curtain is in operation and under heat demand, a 'decimal point'  is shown after the air curtain address.

Quick Options

These are identical to the quick settings for the standard controller so please refer to that section of the manual.



10.3.3 OFF mode.

During normal operation, press and hold the  button for approximately two seconds. The display blanks until you release the button. The heating and fans are now turned off. Releasing the button in less than this time and the action has no effect.





 Where multiple air curtains exist in a network, this action turns off all air curtains.

10.3.4 Settings Mode

10.3.4.1 Activate settings display

To enter the Settings mode press the  button. This will illuminate the screen. Press the  button till the desired setting is shown.

By pressing the  button it will also advance to the next setting.

 Note: If a setting has been altered by using the  or  buttons, it must be confirmed by pressing the  button.

10.3.4.2 Settings displays

Press the  button to advance through the settings. The displays will scroll as follows:

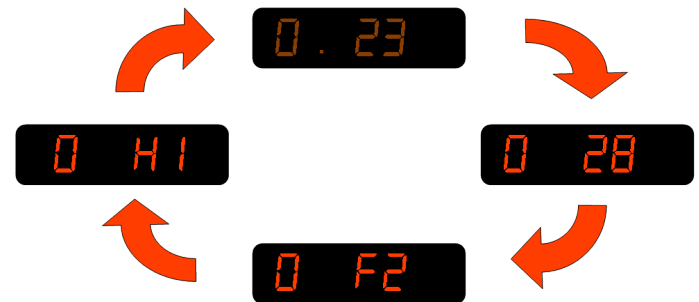

Where multiple air curtains exist in a network and controlled from a single keypad, these will be detected and displayed in turn, for example:

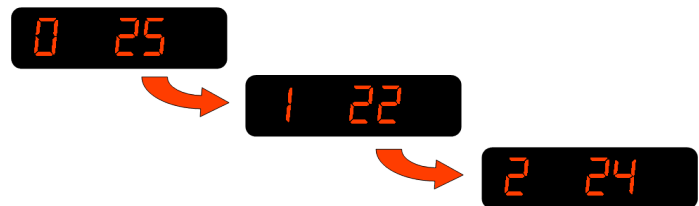

Any air curtain in the network can be accessed by pressing the  button when it's address appears on the display.

The settings can then be accessed as previously described.

10.3.5 Set-up configurations

10.3.5.1 Set fan speed

Once the display becomes illuminated press the the  button once. Display shows the fan speed.

Press  to increase fan speed.

Press  to decrease fan speed.

Three speeds and an 'off' setting are available:

 Speed 1  Speed 2

 Speed 3  Fan 'off'

10.3.5.2 Set heat

Press the  button again Display shows the heat setting.

Press  to set heat 'on'.

Press  to set heat 'off'.

If no button pressed for 2 seconds, display will revert to normal user. e.g. 

10.3.5.3 Set temperature

Press the  button once to allow changes to be made.

Press  to increase temperature set point. (max 35°C)

Press  to decrease temperature set point. (min 16°C)

Display shows for example: 

10.3.5.4 Networked air curtains

Where multiple air curtains exist in a network and controlled from a single keypad, these will be detected and displayed in turn, for example:









Any air curtain in the network can be accessed by pressing

 when it's address appears on the display.

The settings can then be changed as previously described.



10.3.6 Engineers settings

Other options are available in engineer's mode.

To access the engineers mode either: press and hold the  button for a few seconds until the display goes blank, then press  briefly. The display will show  or

Power-up the system with the  and  buttons pressed and release when the display goes blank the display will show



As in normal mode, Engineers set-up mode is started by pressing the  button whereupon the display will illuminate. Advance through the normal modes settings of temperature, fan and heat by pressing the  button.

Pressing the  button again advances to further options to allow other settings of the system. The engineers set-up options listed herewith depend various factors e.g. optional door switch, multiple air curtains etc.

 *Notes: If a panel has never before been run, it automatically starts in engineer's mode when first powered-up.*

 *Engineer's mode automatically self-clears after approximately 10 minutes of non-activity on the buttons.*

10.3.6.1: Door link settings:

This provides an alternative fan speed and heat setting which is activated only when the door link is open circuit.

The fan speed is accessed by pressing the the  button until the display shows:  Use the  and  buttons to change the setting.

 Fan OFF

 Fan speed 1

 Fan speed 2

 Fan speed 3

The temperature setting when the door link is open circuit is accessed by pressing the  button until the display shows:



Use the  and  buttons to alter the temperature value.

0 t0 Heat OFF

0 t1 5°C

0 t2 10°C

0 t3 15°C

0 t4 20°C

0 t5 25°C

0 t6 30°C

0 t7 35°C

10.3.6.2 Link-group interlock

If there is more than one air curtain, a group interlock option may be set. This provides an alternative fan speed and heat setting when activated by certain external connections on individual air curtains.

This function is accessed by pressing the **SELECT** button until the display shows 0 C0 (where '0' is the air curtain address to be used as a master unit for interlocks.)

See table to follow for possible settings.

0 d0 Default setting

0 d1 or 0 d1 Master setting range

0 d2 Other air curtains

See table below for possible settings.

Master setting	Function
1	Timer/BMS interlock
2	Door interlock
3	Timer/BMS/door interlock
4	Stat interlock
5	Timer/BMS/stat interlock
6	Stat/door interlock
7	Timer/BMS/stat/door interlock

10.3.6.3 All controllers

This function is accessed by pressing the **SELECT** button until the display shows **≡ 35**

Using this setting all air curtains in a network respond to the same settings. Settings for individual air curtains can still be changed if required.

10.3.6.4 External temperature

This is only displayed if the factory supplied optional external temperature sensor is connected to the air curtain.

This function is accessed by pressing the **SELECT** button until the display shows: **o 25**

Use the **+** and **-** buttons to change to the desired temperature setting.

If the external temperature is equal to the set temperature, all air curtains are turned off. The temperature must then drop to 3°C below the set temperature before the air curtains are turned back on.

! Note: for multiple air curtains - more than one can have an external sensor connected. When this is the case the sensor values are displayed as an average. (If one external sensor goes faulty, the average is worked out from the remaining working ones).

10.3.6.5 External temperature offset

This function is accessed by pressing the **SELECT** button until the display shows: **004**

This setting allows the temperature setpoint to be automatically increased as the external temperature falls to, or below, zero. For instance, a setting of 4 means a +4°C offset at 0°C. The maximum offset is 9°C. If this feature is not required the setting should be: **000**

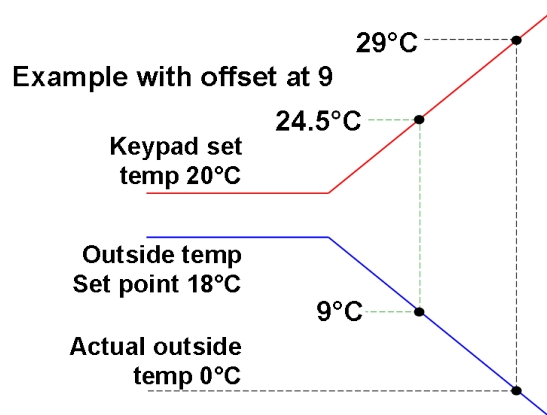



! Note: When more than one air curtain is used, this feature

will only work under the 'all controllers' setting.

10.3.6.6 Temperature limits

This function is accessed by pressing the  button until the display shows:



 and  respectively
i.e. maximum and minimum set limits for set temperature.

Use the  and  buttons to change to the desired limit temperature settings.



The maximum (default 35°C) may be set anywhere between the current minimum and 50°C, and the minimum, (default 16°C) may be set anywhere between 3°C and the current maximum.

To exit the engineers mode press and hold the  button for a few seconds.

10.3.7 Power-up Manual Reset

The system can be reset by powering-up the panel whilst holding down the  and  buttons. The display shows the 'start' pattern but then goes blank.

Release the buttons where upon the display resumes and the system addressing commences, finding only those air curtains which are actually connected and working.

If  appears on the display, press and hold the  button for a few seconds then release. The display will then return to the normal mode.

10.3.8 Air curtain addressing (standard and SmartElec)

All air curtains work on an address to communicate with the keypad and are supplied with an default address of '0'.

Where multiple air curtains exist in a network they must be re-addressed using a unique address (0-9/A-F). This is achieved using a 4 way bitswitch mounted on the base unit PCB (see photo on following page).

The keypad will check all addresses on first power up and this is displayed as the first digit on the display (in a network set up, all addressees will be viewed in rotation).

 *Note: If any address is altered after initial power up or an air curtain removed after initial installation, the keypad will also retain the original address although unable to respond.*

To remove this unwanted address(s) follow the details in 10.3.7

Power-up Manual Reset.

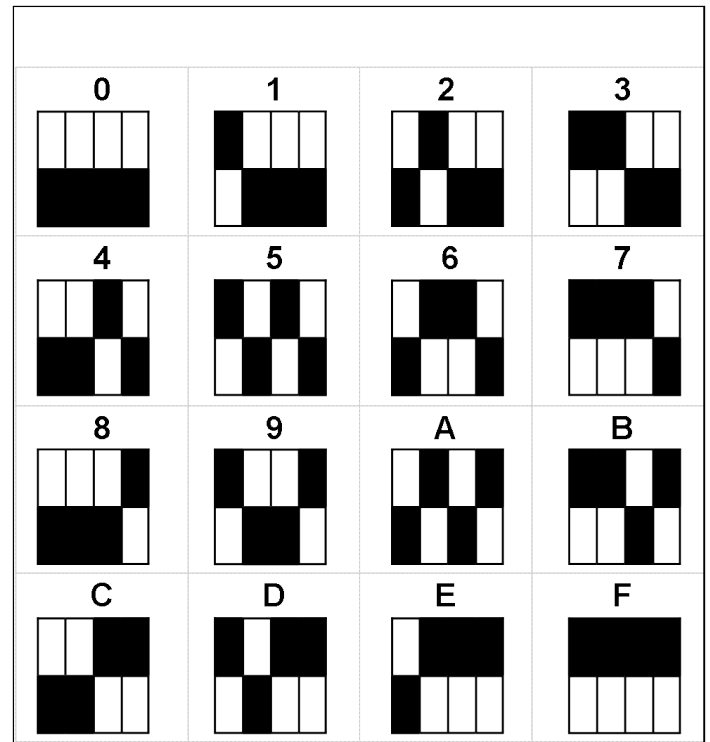
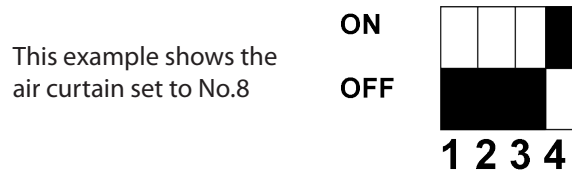

fig. 16. Air curtain address numbers

The black shaded areas represent the switch position.



 **WARNING:**

THIS AIR CURTAIN SHOULD NOT BE INSTALLED WHERE THERE IS A CORROSIVE ATMOSPHERE

Bitswitch location on PCB

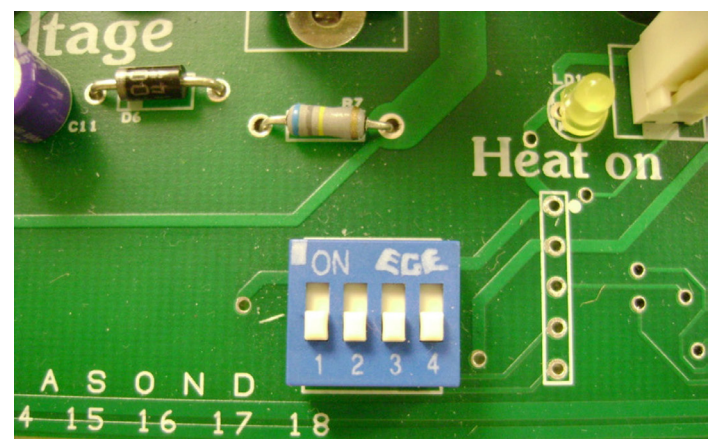

10.3.9 Keypad sequences (standard /LPHW)

Standard - Normal display

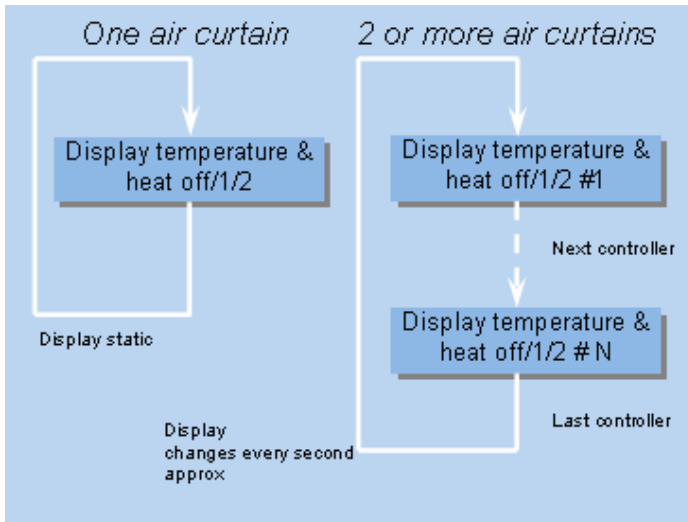

LPHW - Normal display

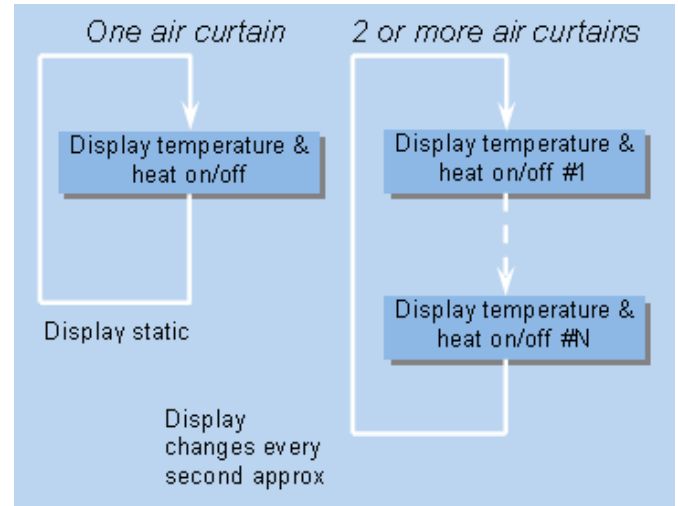

Standard - Normal set-up

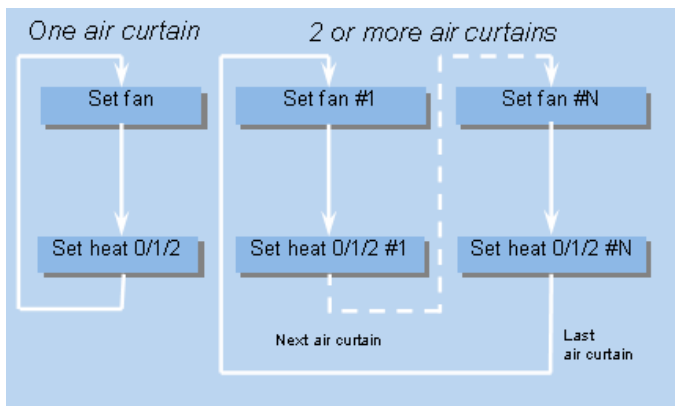

LPHW - Normal set-up

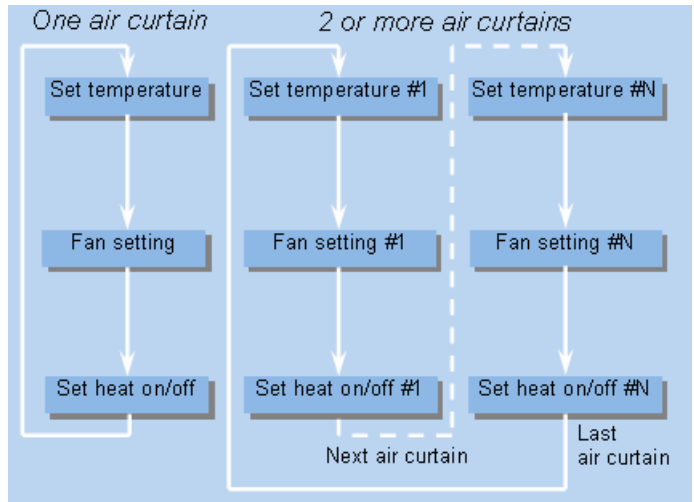

Standard - Engineers mode display

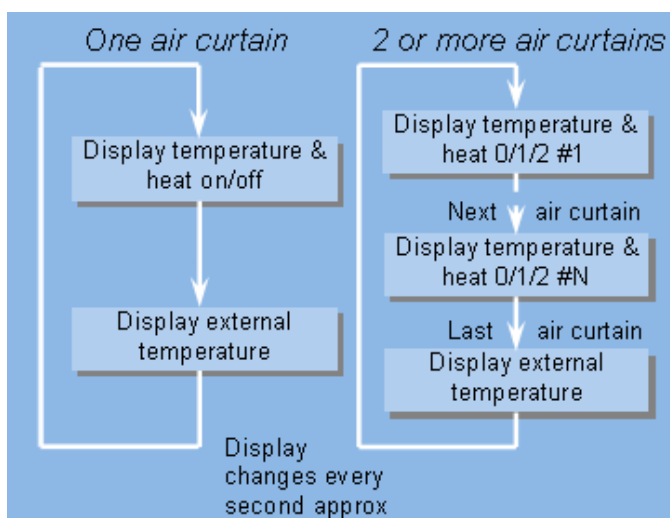

LPHW - Engineers mode display

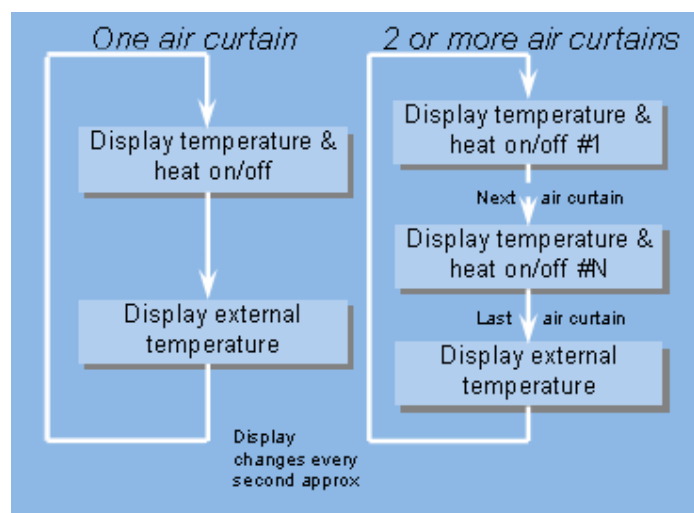

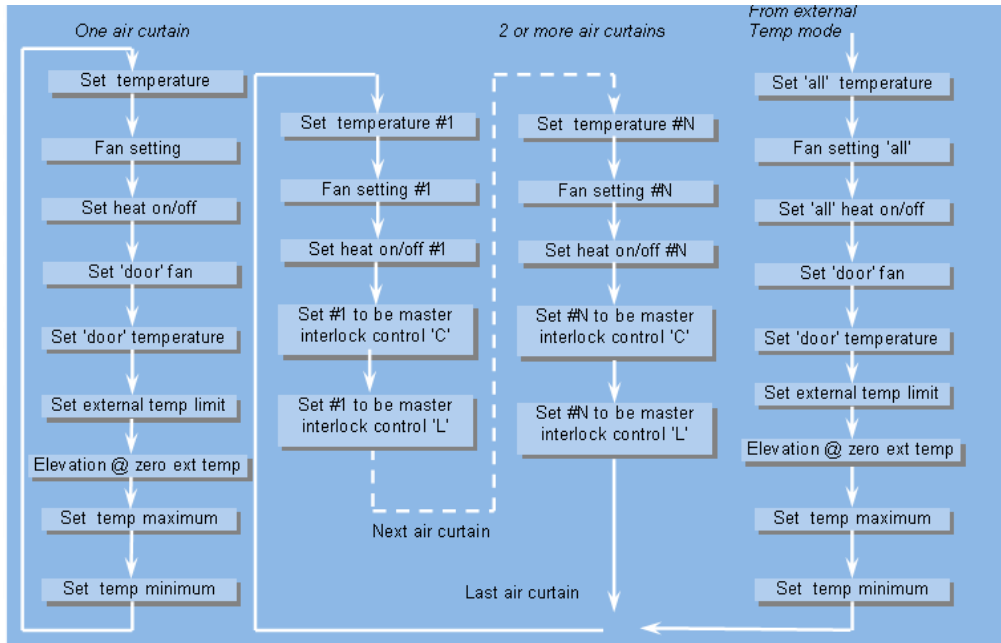

Standard - Engineers mode set-up

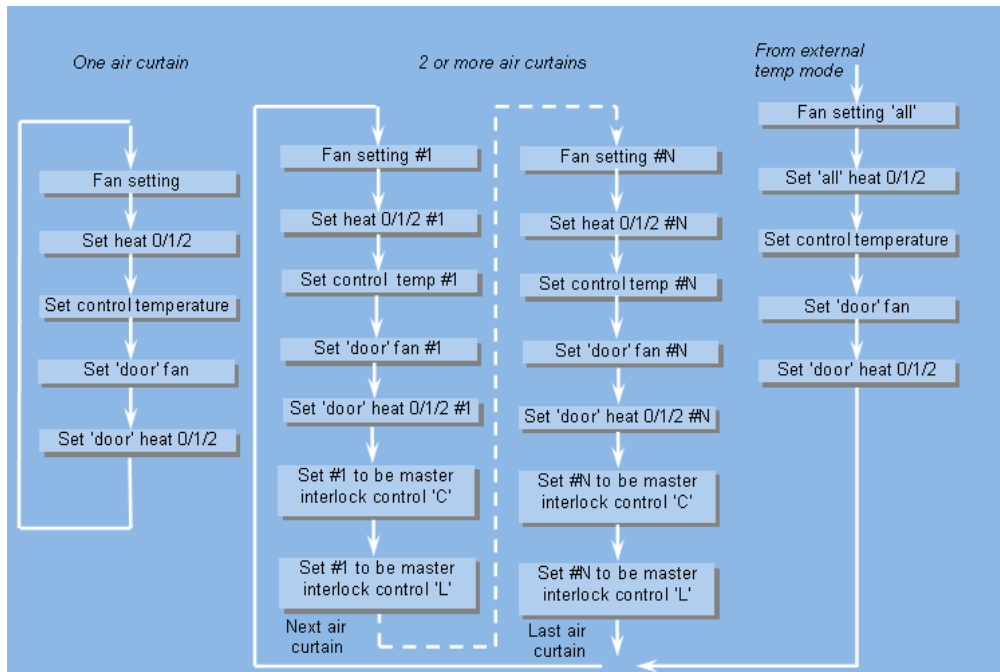

10.3.10 Keypad sequences (SmartElec controller)

Engineers mode display

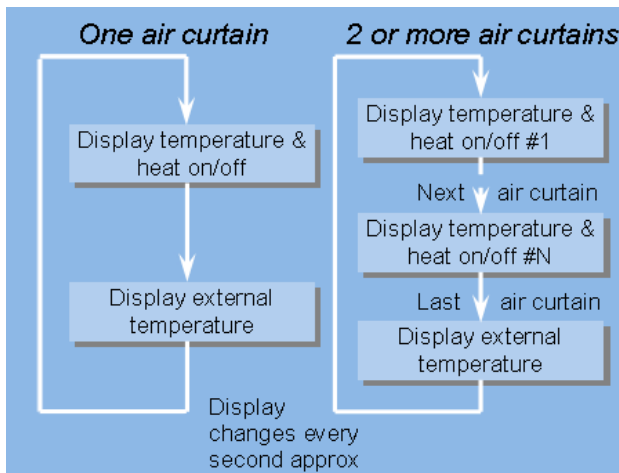

Normal set-up

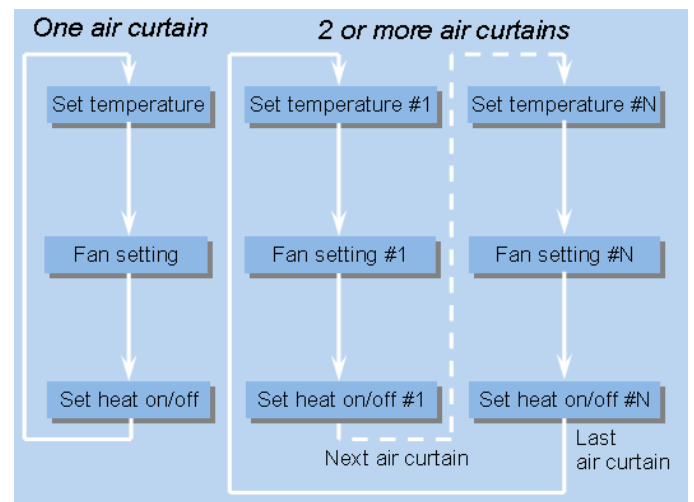

Normal display

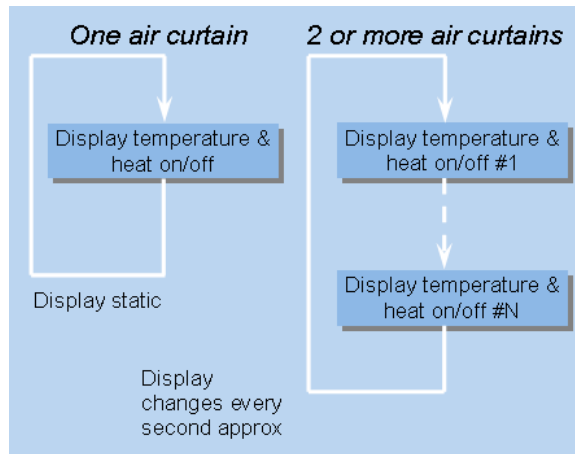

Engineers mode set-up

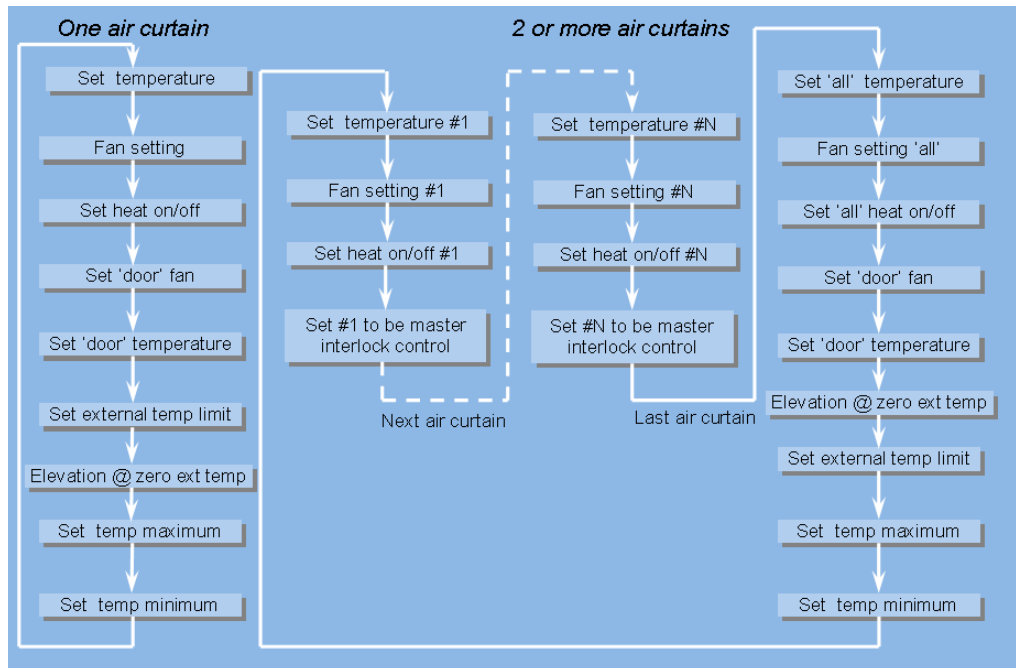

Document reference number: **D301051**
 Replaces Document reference number: **D301021 R1**



Nortek Global HVAC (UK) LTD

Fens Pool Avenue, Brierley Hill
 West Midlands, DY5 1QA
 United Kingdom

Tel: +44 (0) 1384 489 250

Fax: +44 (0) 1384 489 707

Email: reznorsales@nortek.com

Web: www.reznor.eu/

AFFIX AGENTS DETAILS HERE