

ACR RECESSED AIRCURTAIN

ELECTRICALLY HEATED, AMBIENT & LPHW

INSTALLATION AND OPERATING MANUAL



INDEX

Section

General information -----	1
Dimensions -----	2
Technical Specification -----	3
Wiring Details -----	4
Installation Details -----	5
Servicing & Maintenance -----	6
Spare Parts -----	7
Fault Finding -----	8
Parts replacement -----	9
User Instructions -----	10

WARNINGS

- 1 This appliance must only be installed by a competent person in accordance with the requirements of the Codes of Practice or the rules in force.
- 2 All external wiring **MUST** comply with the current IEE wiring regulations.
- 3 Warning this appliance must be earthed.



Document Index.

1 Installation Requirements

- 1.1 Introduction
- 1.2 General
- 1.3 Electrical Supply
 - 1.3.1 Electronic Controller
 - 1.3.2 SmartElec2 Controller
- 1.4 Location
- 1.5 Clearance Distance
- 1.6 Health and Safety
- 1.7 Standards

2 Dimensions

- 2.1 ACR Air Curtain
- 2.2 Electronic Controller
- 2.3 Optional SmartElec2 Controller

3 Technical Specifications

- 3.1 Electrical Heated, Std Capacity 6&9kW 1P
- 3.2 Electrical Heated, Std Capacity 9-18kW
- 3.3 Electrical Heated, High Capacity 12-18kW
- 3.4 Ambient, Std Capacity
- 3.5 Ambient, High Capacity
- 3.6 LPHW, Std Capacity
- 3.7 LPHW, High Capacity
- 3.8 Electronic Controller
- 3.9 SmartElec2 Controller

4 Wiring Diagrams

- 4.1 Installer Wiring Electrically Heated 6&9kW 1Pha
- 4.2 Installer Wiring Electrically Heated 9&12kW 3Pha
- 4.3 Installer Wiring Electrically Heated 18kW 3Pha
- 4.4 Installer Wiring Ambient
- 4.5 Installer Wiring LPHW
- 4.6 Factory Wiring Electrically Heated ACR100/150 6&9kW 1Pha
- 4.7 Factory Wiring Electrically Heated ACR200 9kW 1Pha
- 4.8 Factory Wiring Electrically Heated ACR100/150 9&12kW 3Pha
- 4.9 Factory Wiring Electrically Heated ACR120 12kW 3Pha
- 4.10 Factory Wiring Electrically Heated ACR200/180 18kW 3Pha
- 4.11 Factory Wiring Ambient ACR100/150 1Pha
- 4.12 Factory Wiring Ambient ACR200/120/180 1Pha
- 4.13 Factory Wiring LPHW ACR100/150 1Pha
- 4.14 Factory Wiring LPHW ACR200/120/180 1Pha
- 4.15 Network Wiring Electronic Controller
- 4.16 Installer Wiring SmartElec2 Controller
- 4.17 Factory Wiring SmartElec2 Controller ACR100/150
- 4.18 Factory Wiring SmartElec2 Controller ACR200
- 4.19 Network Wiring SmartElec2 Controller

5 Installation Details

- 5.1 Mounting
- 5.2 Electrical Supply
- 5.3 Installation
- 5.4 Standard Controller
- 5.5 Option SmartElec2 Controller
- 5.6 LPHW only
- 5.7 Wiring

6 Servicing & Maintenance Instructions

7 Spare Parts

- 7.1 General
- 7.2 AC-ACR-PANEL Controller
- 7.3 SmartElec2 Controller
- 7.4 Heating mediums

8 Fault Finding Guide

- 8.1 General
- 8.2 Electrical Heated
- 8.3 Electronic Controller
- 8.4 Optional SmartElec2 Controller
 - 8.4.1 Fault Code chart
 - 8.4.2 LED indication

9 Replacing Parts

- 9.1 Electrical Element
 - 9.1.1 SE
 - 9.1.2 HE
- 9.2 Rotor and Motor
 - 9.2.1 SE
 - 9.2.2 HE
- 9.3 LPHW Coil

10 User and Operating Instructions

10.1 Standard Keypad

- 10.1.1 Keypad Buttons
- 10.1.2 Operation
- 10.1.3 Engineers Settings
 - 10.1.3.1 Auto Mode
 - 10.1.3.2 Door Switch Mode

10.2 Optional SmartElec2 Controller

- 10.2.1 Keypad Buttons
- 10.2.2 Keypad Display
 - 10.2.2.1 Normal Mode Display
 - 10.2.2.2 Normal Operation
- 10.2.3 Off Mode
- 10.2.4 Settings Mode
 - 10.2.4.1 Activate Settings Display
 - 10.2.4.2 Settings Display
- 10.2.5 Set Up Configuration
 - 10.2.5.1 Set Fan Speed
 - 10.2.5.2 Set Heat
 - 10.2.5.3 Set Temperature
 - 10.2.5.4 Networked Air Curtains
- 10.2.6 Engineers Settings
 - 10.2.6.1 Door Link Settings
 - 10.2.6.2 Link-group Interlock
 - 10.2.6.3 All Air Curtains
 - 10.2.6.4 External Temperature
 - 10.2.6.5 External Temperature Offset
 - 10.2.6.6 Temperature Limits
- 10.2.7 Power-up Manual Reset
- 10.2.8 Air Curtain Addressing
- 10.2.9 Keypad Sequences

General Information

1.1 Introduction

This instruction manual describes the Airbloc ACR Recessed range of air curtains.

Models range from 1000mm to 2000mm in length, in both Standard and High capacity and are available in either Electrically heated, Ambient or LPHW. They are designed for discreet positioning in a suspended ceiling or bulkhead in the doorways of retail or commercial premises. Optional case for doorways with restricted space and no suspended ceiling/bulkhead are available.

Each air curtain is supplied with a fully electronic controller giving multi fan and heat settings (electrically operated units) via a simple key pad which can be mounted up to 50m from the air curtain. Optional BMS time control, external thermostats and door interlocks can be installed.



fig.1. AC-ACR-PANEL program keypad

The **AC-ACR-PANEL programmer** shown above allows the user to control either a single air curtain, or a network of up to 6 air curtains with the same settings, and provides the following functions:-

- Heat On Off or Auto via optional thermostat
 - Off or Low, Medium and High Fan Speeds
- For further details please refer to section 10.2

Alternatively on electrically heated models, an optional SmartElec2 control system consists of a base unit (installed within the air curtain) and a program panel that can be installed remote from the air curtain. Usually, the program panel is mounted at a low level from the air curtain for user access and to a maximum distance of 100m. The base unit and program panel are linked by low voltage cable as specified in these instructions.

The **SmartElec2 factory fitted base unit** provides terminals for 3 phase supply connection and the low voltage program panel wires. The SmartElec2 base unit rapidly pulses energy to the heating elements. This combined with the inbuilt intelligent sensor control, maintains a fixed outlet temperature, thereby reducing energy consumption as compared to an air curtain without the SmartElec2 control.



fig.2. SmartElec2 Controller

The **SmartElec2 program panel** shown above allows the user to control either a single air curtain, or a network of up to 16 air curtains, each with different settings if required, and provides the following functions:-

- Heat On or Off
- Off or Low, Medium and High Fan Speeds
- Air Outlet Temperature

For further details please refer to section 10.4

1.2 General

All installations must be in accordance with the regulations in force in the country of use.

These instructions must be handed to the user on completion of the installation.

Installers and service engineers must be able to demonstrate competence and be suitably qualified in accordance with the regulations in force in the country of use.

To ensure continued and safe operation it is recommended that the appliance is serviced annually.

The manufacturer, offers a maintenance service. Details are available on request.

The air curtain outlet grille and case air inlet slots must not be obstructed during use.

1.3 Electrical Supply.

For full electrical loadings, please refer to the individual technical data sheets within this manual.

It is recommended that the electrical supply to the base unit in the air curtain is via an appropriate switched isolator in accordance with the regulations in force in the country of use and must be via a fused isolator having a contact separation of greater than 3mm in all poles.

BMS control, time switches, room thermostats and door interlocks can be installed at the discretion and responsibility of the installer.

All units must be wired in accordance with I.E.E regulations for the Electrical Equipment of Buildings and the installer should ensure that a suitable isolating switch is connected in the mains supply.

Warning

For safety reasons a good earth connection must ALWAYS be made to the heater and control box.

1.3.1 Electronic controller

Electrically heated supply is either 230V 1 phase (6 and 9kW options) or 415V 3 phase (9 to 24kW), Neutral and Earth. Max cable inlet size is 4mm².

Ambient and LPHW supply is 230V 1 phase, Neutral and Earth. Max cable inlet size is 4mm².

Remote unit is wired to the base unit via a screened twisted pair 28AWG (or direct equiv).

1.3.2 SmartElec2 controller

Electrically heated supply is 415V 3 phase, neutral and earth. Max cable inlet size is 10mm².

Remote unit is wired to the base unit via pre-wired 4core cable.

Networked air curtain interconnects via pre-wired 4 core cable.

1.4 Location.

Airbloc units should be installed horizontally directly over the door opening. It is recommended that the air curtain is installed on the inside of the building, within the ceiling void or roof space.

Care must be taken to allow complete free air movement into the inlet grilles of the unit to ensure correct working operation of the air curtain. The discharge opening should be as close to the top of the door as possible and to cover the entire door width.

Units can be mounted adjacent to each other to cover the full door opening across wider entrances.

1.5 Clearance distances

It is recommended that a minimum clearance of 100mm is allowed around the case sizes detailed

below. The clearance allows for cable entry and prevents combustible surfaces overheating.

The minimum mounting height (floor to grille) is 1.8m. The recommended mounting height is 3m for standard and 4m for high capacity models.

1.6 Health and Safety

Sole liability rests with the installer to ensure that all site safety procedures are adhered to during installation.

Sole liability rests with the installer to ensure that protective safety wear such as hand, eye, ear and head protection is used during installation of the product.

Do not rest anything especially ladders against the product.

1.7 Standards

Units conform to the European electrical standard BS EN 60335-2-30 and to the following European CE directives-

2006/95/EC - low voltage;

2004/108/EC - electromagnetic compatibility.

2. Dimensions.

2.1 ACR Air Curtain

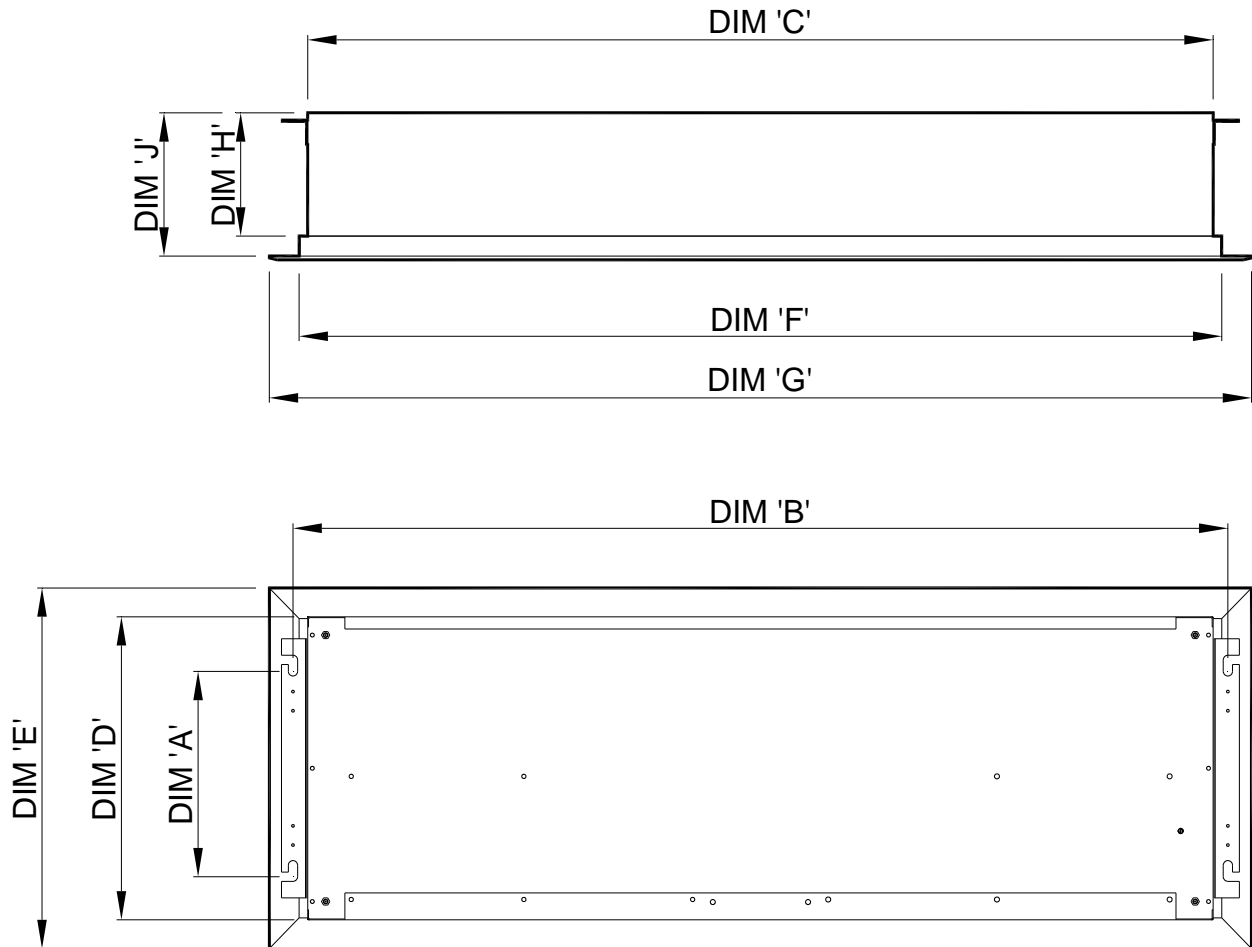

Dimensional detail (mm)

Size	ACR100SE6/9; ACR100SW9; ACR100SA	ACR150SE12; ACR150SW12; ACR150SA	ACR200SE18; ACR200SW18; ACR200SA	ACR120HE12; ACR120HW12; ACR120HA	ACR180HE18; ACR180HW18; ACR180HA
A	253			407	
B	1220	1520	2020	1185	1785
C	1182	1482	1982	1150	1750
D	395			550	
E	454			608	
F	1205	1505	2005	1150	1750
G	1242	1542	2095	1210	1810
H	160			180	
J	200			220	

2.2 AC-ACR-PANEL program keypad

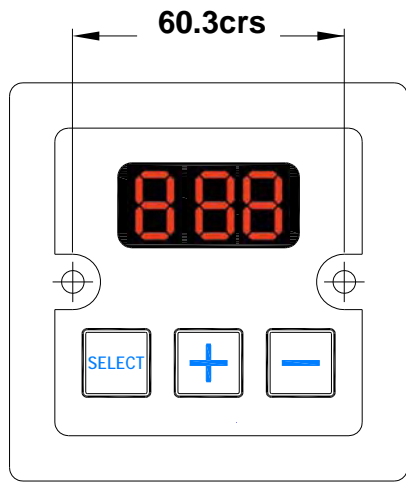

Fig.3. Surface mount

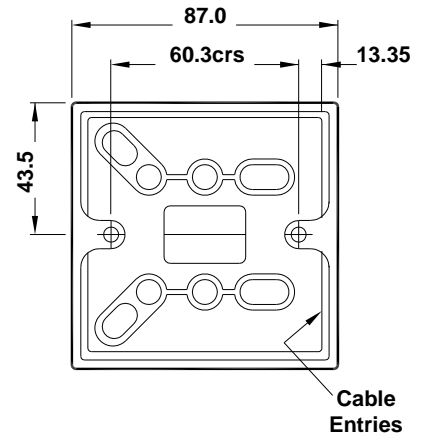
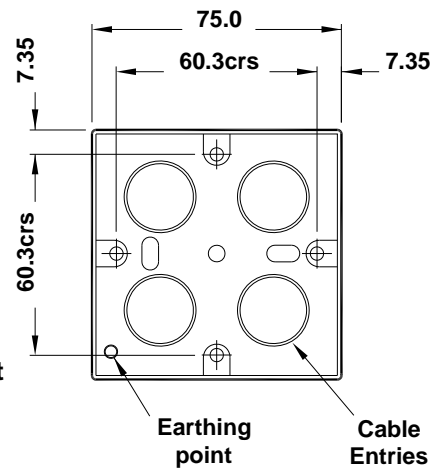
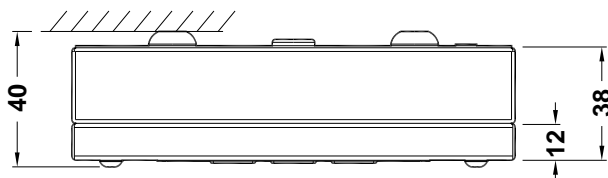
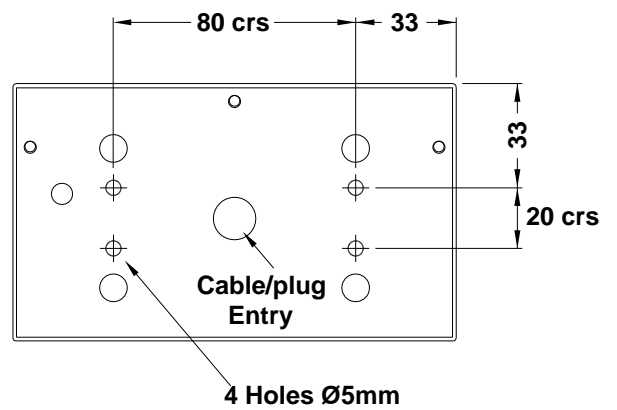
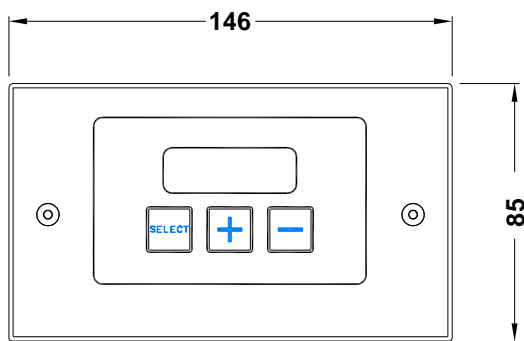

Fig.4. optional flush mount



2.3 Optional SmartElec2 Controller dimensions



3. Technical Specification.

3.1 (Single Phase only)		ACR100SE6-1PH	ACR150SE6-1PH	ACR200SE9-1PH	
General Data					
Maximum height	M	3.0			
Door width	M	1.2	1.5	2.0	
Heat medium		Electric heated			
Heat setting	kW	3 / 6		4.5 / 9	
Fan type / dia		Crossflow / 100mm			
Fan settings		3			
Switching type		AC-ACR-PANEL			
Weight	kg	28.0	34.0	49.0	
Electrical Data					
Supply voltage		230V 1ph 50Hz			
Total load	kW	6.1		9.1	
	amps	26.5		39.6	
Motor power	W	60		90	
Max Starting current*	amps	0.96		1.5	
Max Running current*	amps	0.65		0.75	
External fuse size amps	amps	32		45	
Programmer keypad	pt. no.	AC-ACR-PANEL			
Program keypad control wiring		Screened twisted pair 28AWG			
Cable terminal size		6.0mm ² Max			
Mains terminal block position		Separate din rail L1; N & E			
Control terminal block position		Right side of base unit terminals +12V, DATA & GND			
Air Data					
Air volume	<i>Low speed</i>	m ³ /h	1164	1475	2013
	<i>Medium speed</i>	m ³ /h	1405	1780	2432
	<i>High speed</i>	m ³ /h	1646	2085	2851
Air velocity	<i>Low @ 0M</i>	m/s	4.3		5.4
	<i>Medium @ 0M</i>	m/s	5.6		6.9
	<i>High @ 0M</i>	m/s	7.0		8.4
	<i>High @ 1M</i>	m/s	3.5		4.2
	<i>High @ 2M</i>	m/s	1.6		2.1
	<i>High @ 3M</i>	m/s	0.8		1.0
Delta T	<i>Low speed</i>	°C	17	13	26
	<i>Medium speed</i>	°C	15	11	23
	<i>High speed</i>	°C	13	9	20
Noise level @ 1M <i>Free field</i>	<i>Low speed</i>	dBA	59		
	<i>Medium speed</i>	dBA	62		
	<i>High speed</i>	dBA	64		
Dims Data					
Length	mm	1182	1482	1982	
Depth (width)	mm	395			
Total height*	mm	200			
Outlet length	mm	1125	1425	1945	
Outlet depth (width)	mm	85			
Grille height	mm	40			
Mounting bracket centres length	mm	1220	1520	2020	
Side to 1 st bracket centre	mm	18			
Mounting bracket centres height	mm	Flush with top of unit			
Top to 1 st bracket centre	mm	Flush with top of unit			

* Motor current only at high speed

3.2			ACR100SE9	ACR150SE12	ACR200SE18
General Data					
Maximum height	M		3.0		
Door width	M	1.2	1.5	2.0	
Heat medium		Electric heated			
Heat setting	kW	4.5 / 9	6 / 12	9 / 18	
Fan type / dia		Crossflow / 100mm			
Fan settings		3			
Switching type		AC-ACR-PANEL / SmartElec2			
Weight	kg	28.0	34.0	49.0	
Electrical Data					
Supply voltage		415V 3ph 50Hz			
Total load	kW	9.1	12.1	18.1	
	A/pha	12.6	16.8	25.2	
Motor power	W	60			90
Max Starting current*	amps	0.96			1.5
Max Running current*	amps	0.65			0.75
External fuse size amps	A/pha	16	20	32	
Programmer keypad	pt. no.	AC-ACR-PANEL			
Program keypad control wiring		Screened twisted pair 28AWG			
Cable terminal size		4.0mm ² Max		6.0mm ² Max	
Mains terminal block position		Bottom of base unit. Terminals N; L1; L2 & L3			Separate din rail E: N; L1; L2 & L3
Control terminal block position		Right side of base unit terminals +12V, DATA & GND			
*** SmartElec Energy Saving Control	pt. no.	SELEC2BU			
SmartElec Energy Saving Control wiring		4 core pre-wired			
Cable terminal size		10.0mm ² Max			
Mains terminal block position		SmartElec2 Base Unit - terminals N; L1; L2 & L3			
Control terminal block position		SmartElec2 Base Unit			
Air Data					
Air volume	<i>Low speed</i>	m ³ /h	1164	1475	2013
	<i>Medium speed</i>	m ³ /h	1405	1780	2432
	<i>High speed</i>	m ³ /h	1646	2085	2851
Air velocity	<i>Low @ 0M</i>	m/s	4.3		5.4
	<i>Medium @ 0M</i>	m/s	5.6		6.9
	<i>High @ 0M</i>	m/s	7.0		8.4
	<i>High @ 1M</i>	m/s	3.5		4.2
	<i>High @ 2M</i>	m/s	1.6		2.1
	<i>High @ 3M</i>	m/s	0.8		1.0
Delta T	<i>Low speed</i>	°C	26	25	21
	<i>Medium speed</i>	°C	23	22	20
	<i>High speed</i>	°C	20	19	19
Noise level @ 1M in free field	<i>Low speed</i>	dBA	59		
	<i>Medium speed</i>	dBA	62		
	<i>High speed</i>	dBA	64		
Dims Data					
Length	mm	1182	1482	1982	
Depth (width)	mm	395			
Total height*	mm	200			
Outlet length	mm	1125	1425	1945	
Outlet depth (width)	mm	85			
Grille height	mm	40			
Mounting bracket centres length	mm	1220	1520	2020	
Side to 1 st bracket centre	mm	18			
Mounting bracket centres height	mm	Flush with top of unit			
Top to 1 st bracket centre	mm	Flush with top of unit			

* Motor current only at high speed

**Suffix with -SM for SmartElec2 Energy Saving Control.

3.3			ACR120HE12	ACR180HE18
General Data				
Maximum height	M		4.0	
Door width	M		1.2	1.8
Heat medium			Electric heated	
Heat setting	kW		6 / 12	9 / 18
Fan type / dia			Crossflow / 150mm	
Fan settings			3	
Switching type			AC-ACR-PANEL / SmartElec2	
Weight	kg		38.0	55.0
Electrical Data				
Supply voltage			415V 3ph 50Hz	
Total load	kW		12.4	18.4
	A/pha		17.3	25.6
Motor power	W		370	
Max Starting current*	amps		5.0	
Max Running current*	amps		2.1	
External fuse size amps	A/pha		20	32
Programmer keypad	pt. no.		AC-ACR-PANEL	
Program keypad control wiring			Screened twisted pair 28AWG	
Cable terminal size			4.0mm ² Max	6.0mm ² Max
Mains terminal block position			Base unit N; L1; L2 & L3	Separate din rail E; N; L1; L2 & L3
Control terminal block position			Right side of base unit terminals +12V, DATA & GND	
*** SmartElec Energy Saving Control	pt. no.		SELEC2BU	
SmartElec Energy Saving Control wiring			4 core pre-wired	
Cable terminal size			10.0mm ² Max	
Mains terminal block position			SmartElec2 Base Unit - terminals N; L1; L2 & L3	
Control terminal block position			SmartElec2 Base Unit	
Air Data				
Air volume	Low speed	m ³ /h	1300	1600
	Medium speed	m ³ /h	1850	2400
	High speed	m ³ /h	2300	3300
Air velocity	Low @ 0M	m/s	6.0	
	Medium @ 0M	m/s	8.5	
	High @ 0M	m/s	11.0	
	High @ 1M	m/s	5.4	5.5
	High @ 2M	m/s	3.6	3.7
	High @ 3M	m/s	2.6	2.5
	High @ 4M	m/s	1.5	1.6
Delta T	Low speed	°C	35	35
	Medium speed	°C	28	27
	High speed	°C	22	22
Noise level @ 3M in free field	Low speed	dBA	50	
	Medium speed	dBA	55	
	High speed	dBA	60	
Dims Data				
Length	mm		1150	1750
Depth (width)	mm		550	
Total height*	mm		227	
Outlet length	mm		1090	1690
Outlet depth (width)	mm		85	
Grille height	mm		6	
Mounting bracket centres length	mm		1185	1785
Side to 1 st bracket centre	mm		17.5	
Mounting bracket centres height	mm		Flush with top of unit	
Top to 1 st bracket centre	mm		Flush with top of unit	

* Motor current only at high speed

**Suffix with -SM for SmartElec2 Energy Saving Control.

3.4		ACR100SA	ACR150SA	ACR200SA	
General Data					
Maximum height	M	3.0			
Door width	M	1.2	1.5	2.0	
Heat medium		Ambient			
Fan type / dia		Crossflow / 100mm			
Fan settings		3			
Switching type		AC-ACR-PANEL			
Weight	kg	28	34	49	
Electrical Data					
Supply voltage		230V 1ph 50Hz			
Total load	kW	0.06	0.09		
	amps	0.26	0.4		
Motor power	W	60	90		
Max Starting current*	amps	0.96	1.5		
Max Running current*	amps	0.65	0.75		
External fuse size amps	amps	3			
Programmer keypad	pt. no.	AC-ACR-PANEL			
Program keypad control wiring		Screened twisted pair 28AWG			
Cable terminal size		4.0mm ² Max			
Mains terminal block position		Base unit L1; N + E			
Control terminal block position		Right side of base unit terminals +12V, DATA & GND			
Air Data					
Air volume	<i>Low speed</i>	m ³ /h	1164	1475	2013
	<i>Medium speed</i>	m ³ /h	1405	1780	2432
	<i>High speed</i>	m ³ /h	1646	2085	2851
Air velocity	<i>Low @ 0M</i>	m/s	4.3		5.4
	<i>Medium @ 0M</i>	m/s	5.6		6.9
	<i>High @ 0M</i>	m/s	7.0		8.4
	<i>High @ 1M</i>	m/s	3.5		4.2
	<i>High @ 2M</i>	m/s	1.6		2.1
	<i>High @ 3M</i>	m/s	0.8		1.0
Noise level @ 1M in free field	<i>Low speed</i>	dBA	59	62	
	<i>Medium speed</i>	dBA	62	64	
	<i>High speed</i>	dBA	64	66	
Dims Data					
Length	mm	1182	1482	1982	
Depth (width)	mm	395			
Total height*	mm	200			
Outlet length	mm	1125	1425	1945	
Outlet depth (width)	mm	85			
Grille height	mm	40			
Mounting bracket centres length	mm	1220	1520	2020	
Side to 1 st bracket centre	mm	18			
Mounting bracket centres height	mm	Flush with top of the unit			
Top to 1 st bracket centre	mm	Flush with top of the unit			

* Motor current only at high speed

3.5			ACR120HA	ACR180HA
General Data				
Maximum height	M		4.0	
Door width	M		1.2	1.8
Heat medium			Ambient	
Fan type / dia			Crossflow / 150mm	
Fan settings			3	
Switching type			AC-ACR-PANEL	
Weight	kg		40.0	58.0
Electrical Data				
Supply voltage			230V 1ph 50Hz	
Total load	kW		0.4	
	amps		1.6	
Motor power	W		370	
Max Starting current*	amps		5.0	
Max Running current*	amps		2.1	
External fuse size amps	Amps		10	
Programmer keypad	pt. no.		AC-ACR-PANEL	
Program keypad control wiring			Screened twisted pair 28AWG	
Cable terminal size			4.0mm ² Max	
Mains terminal block position			Base unit L1; N + E	
Control terminal block position			Right side of base unit terminals +12V, DATA & GND	
Air Data				
Fan setting			2	
Air volume	<i>Low speed</i>	m ³ /h	1300	1600
	<i>Medium speed</i>	m ³ /h	1850	2400
	<i>High speed</i>	m ³ /h	2300	3300
Air velocity	<i>Low @ 0M</i>	m/s	6.0	
	<i>Medium @ 0M</i>	m/s	8.5	
	<i>High @ 0M</i>	m/s	11.0	
	<i>High @ 1M</i>	m/s	5.5	5.2
	<i>High @ 2M</i>	m/s	3.7	3.6
	<i>High @ 3M</i>	m/s	2.5	2.4
	<i>High @ 4M</i>	m/s	1.6	1.4
Noise level @ 3M <i>in free field</i>	<i>Low speed</i>	dBA	50	
	<i>Medium speed</i>	dBA	55	
	<i>High speed</i>	dBA	60	
Dims Data				
Length	mm	1150	1750	
Depth (width)	mm	550		
Total height*	mm	227		
Outlet length	mm	1090	1690	
Outlet depth (width)	mm	85		
Grille height	mm	6		
Mounting bracket centres length	mm	1185	1785	
Side to 1 st bracket centre	mm	17.5		
Mounting bracket centres height	mm	Flush with top of unit		
Top to 1 st bracket centre	mm	Flush with top of unit		

* Motor current only at high speed

3.6		ACR100SW9	ACR150SW12	ACR200SW18	
General Data					
Maximum height	M	3.0			
Door width	M	1.2	1.5	2.0	
Heat medium		LPHW			
Heat setting	kW	9	12	18	
Fan type / 100mm		Crossflow / 100mm			
Fan settings		3			
Switching type		AC-ACR-PANEL			
Weight	kg	28	34	49	
Electrical Data					
Supply voltage		230V 1ph 50Hz			
Total load	kW	0.06		0.09	
	amps	0.26		0.4	
Motor power	W	60		90	
Max Starting current*	amps	0.96		1.5	
Max Running current*	amps	0.65		0.75	
External fuse size amps	amps	3			
Programmer keypad	pt. no.	AC-ACR-PANEL			
Program keypad control wiring		Screened twisted pair 28AWG			
Cable terminal size		4.0mm ² Max			
Mains terminal block position		Base unit L1; N + E			
Control terminal block position		Right side of base unit terminals +12V, DATA & GND			
Air Data					
Air volume	<i>Low speed</i>	m ³ /h	1164	1475	2013
	<i>Medium speed</i>	m ³ /h	1405	1780	2432
	<i>High speed</i>	m ³ /h	1646	2085	2851
Air velocity	<i>Low @ 0M</i>	m/s	4.3		5.4
	<i>Medium @ 0M</i>	m/s	5.6		6.9
	<i>High @ 0M</i>	m/s	7.0		8.4
	<i>High @ 1M</i>	m/s	3.5		4.2
	<i>High @ 2M</i>	m/s	1.6		2.1
	<i>High @ 3M</i>	m/s	0.8		1.0
Delta T	<i>Low speed</i>	°C	26	25	21
	<i>Medium speed</i>	°C	23	22	20
	<i>High speed</i>	°C	20	19	19
Noise level @ 1M in free field	<i>Low speed</i>	dBA	59		62
	<i>Medium speed</i>	dBA	62		64
	<i>High speed</i>	dBA	64		66
LPHW Data					
LPHW flow	l/s	0.20		0.40	
Fluid pressure drop	kPA	3.8	17.6	20	
Flow & return connection	mm	15		22	
Inlet temp	°C	82			
Outlet temp	°C	71			
Dims Data					
Length	mm	1182	1482	1982	
Depth (width)	mm	395			
Total height*	mm	200			
Outlet length	mm	1125	1425	1945	
Outlet depth (width)	mm	85			
Grille height	mm	40			
Mounting bracket centres length	mm	1220	1520	2020	
Side to 1 st bracket centre	mm	18			
Mounting bracket centres height	mm	Flush with top of the unit			
Top to 1 st bracket centre	mm	Flush with top of the unit			

* Motor current only at high speed

3.7			ACR120HW12	ACR180HW18
General Data				
Maximum height	M		4.0	
Door width	M		1.2	1.8
Heat medium			LPHW	
Heat setting	kW		12	18
Fan type / dia			Crossflow / 150mm	
Fan settings			3	
Switching type			AC-ACR-PANEL	
Weight	kg		40.0	58.0
Electrical Data				
Supply voltage			230V 1ph 50Hz	
Total load	kW		0.4	
	amps		1.6	
Motor power	W		370	
Max Starting current*	amps		5.0	
Max Running current*	amps		2.1	
External fuse size amps	amps		10	
Programmer keypad	pt. no.		AC-ACR-PANEL	
Program keypad control wiring			Screened twisted pair 28AWG	
Cable terminal size			4.0mm ² Max	
Mains terminal block position			Base unit L1; N + E	
Control terminal block position			Right side of base unit terminals +12V, DATA & GND	
Air Data				
Air volume	<i>Low speed</i>	m ³ /h	1600	2900
	<i>Medium speed</i>	m ³ /h	2400	4100
	<i>High speed</i>	m ³ /h	3300	5000
Air velocity	<i>Low @ 0M</i>	m/s	6.0	
	<i>Medium @ 0M</i>	m/s	8.5	
	<i>High @ 0M</i>	m/s	11.0	
	<i>High @ 1M</i>	m/s	5.5	5.2
	<i>High @ 2M</i>	m/s	3.7	3.6
	<i>High @ 3M</i>	m/s	2.5	2.4
	<i>High @ 4M</i>	m/s	1.6	1.4
Delta T	<i>Low speed</i>	°C	35	35
	<i>Medium speed</i>	°C	28	27
	<i>High speed</i>	°C	22	22
Noise level @ 3M <i>in free field</i>	<i>Low speed</i>	dBA	50	
	<i>Medium speed</i>	dBA	55	
	<i>High speed</i>	dBA	60	
LPHW Data				
LPHW Flow	l/s		0.40	0.53
Fluid Pressure Drop	kPA		23	24
Flow & Return connection	mm		15	15
Inlet temp	°C		82	
Outlet temp	°C		71	
Dims Data				
Length	mm		1150	1750
Depth (width)	mm		550	
Total height*	mm		227	
Outlet length	mm		1090	1690
Outlet depth (width)	mm		85	
Grille height	mm		6	
Mounting bracket centres length	mm		1185	1785
Side to 1 st bracket centre	mm		17.5	
Mounting bracket centres height	mm		Flush with top of unit	
Top to 1 st bracket centre	mm		Flush with top of unit	

* Motor current only at high speed

3.8		Program Controller
General Data		
Sensor input	NTC	
Protection	2 x 'slow blow' fuse for the protection of the heater switching devices.	
Fan Output	3 off Relay for High, Medium and Low Fan setting 3A max 240Vac	
Connection	Screw terminals 4 for supply, 6 for heater output, 4 for fan output, 2 for BMS (time) control, 2 for sensor input, 2 for external thermal trip, 2 for external door switch.	
Supply	230V 1Ph or 415 3Ph dependent on model type.	
Dimensions	Program panel 88mm(L) x 88mm(W) max.	
Mounting positions	Program panel fixing centres 60.3mm	
Temperature	5 to 50 °C operating; -20 to 65 °C storage	
Display	Three 7-segment LCD red for parameter display	
Push buttons	3 positive feedback tactile push buttons	

3.9		SmartElec2 Controller
General Data		
Sensor input	NTC	
Control Setpoint	16 to 35 °C in steps of 1 degree	
Temperature Control	Proportional with 1°C hysteresis	
Minimum Power	0% to 99 %	
Cycle time	2 seconds fixed	
Protection	2 x high speed fuse for the protection of the heater switching devices	
Fan Output	3 off Relay for High, Medium and Low Fan setting 3A max 240Vac	
Connection	Screw terminals 5 for supply, 3 for heater output, 4 for fan output, 2 for BMS (time) control, 2 for sensor input, 2 for external thermal trip, 2 for external sensor, 2 for door	
Supply	415 Vrms +/-15% 50/60Hz 5VA max.	
Dimensions	Program panel 146mm(L) x 85mm(W) x 38mm(D) max.	
Mounting positions	Program panel fixing centres 80mm x 20mm	
Temperature	5 to 50 °C operating; -20 to 65 °C storage	
Display	Three 7-segment LCD red for parameter display	
Push buttons	3 positive feedback tactile push buttons	

4. Wiring Diagrams.

4.1 Installer Wiring - Electrically Heated 6 & 9kW SINGLE PHASE ONLY

The program panel is connected to the base unit via a set of 3 way connectors marked "+12V", "DATA" and "GND". Interconnecting wiring is via screened twisted pair 28AWG as shown. **Max length 50m.** It is recommended that this cable is run separately within its own trunking to avoid external interference.

* **External switch** (ie BMS enable) to be volt free and wired via normally open contacts to terminal pair B1, B2. (Contacts closed to enable). Remove factory fitted jumper J1.

** **Door switch** to be volt free and wired via terminal pair D1 & D2 (Contacts closed to enable door mode) refer section 10.1.3.2 - Door switch mode.

*** **Internal/external sensor** to be wired to terminal pair S1 & S2. refer section 10.1.3.1 - Auto mode.

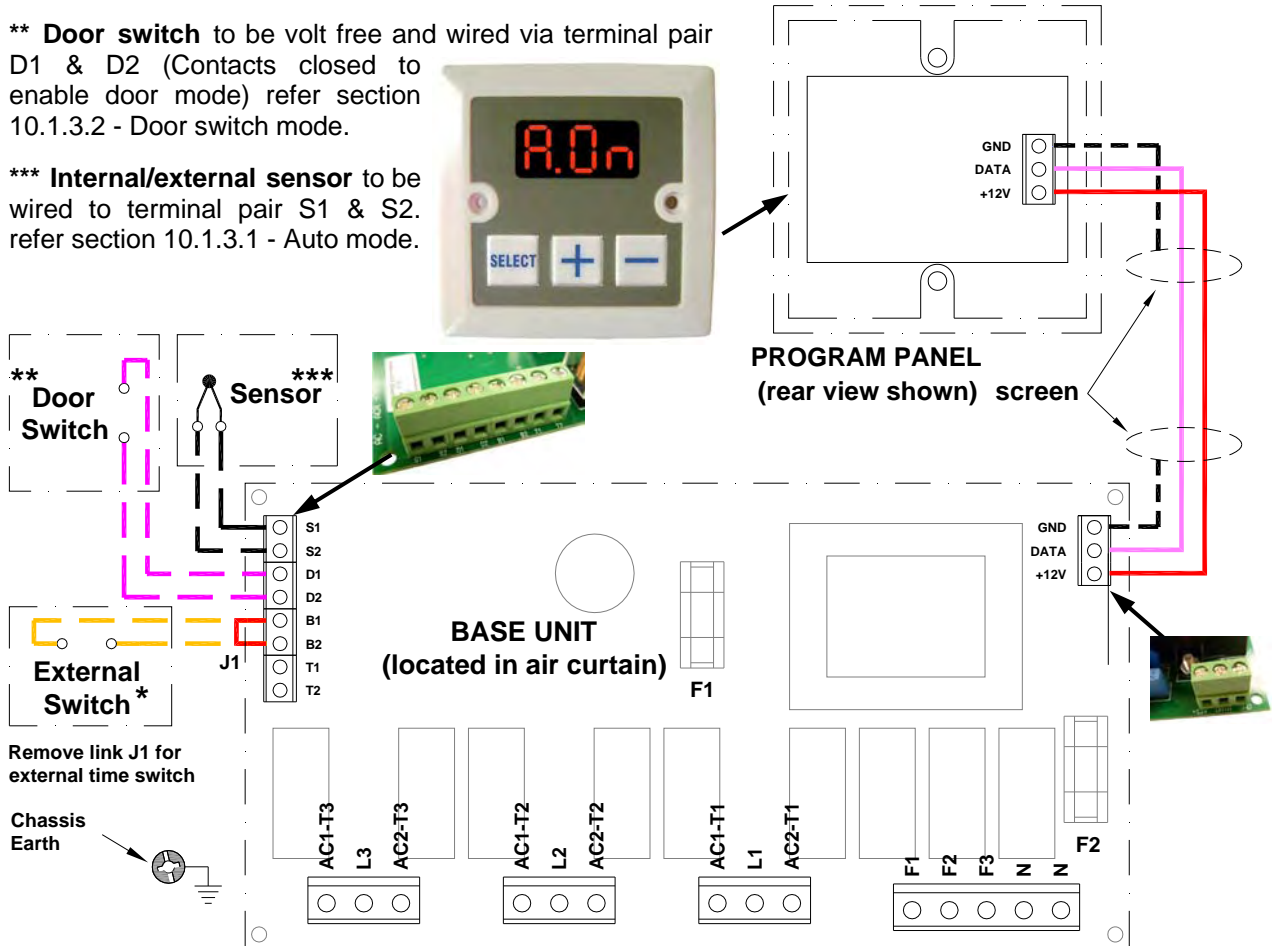

Contractors Terminal

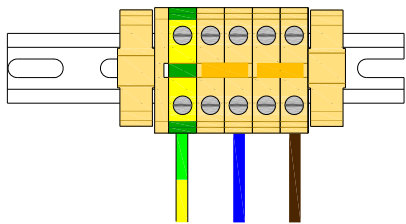

**230V 50Hz
Mains Supply**

Protection

External circuit breaker with the appropriate rating should be installed for the protection of the installation.

Terminal	Description	Cable
N	Neutral	6mm ² max
L1	1 phase supply	6mm ² max
Pcb Terminal		Cable 1.0mm ² max
+12V	Supply to remote unit	
DATA	Data to remote unit	
GND(s)	0v Terminal	
D1, D2	Option door contact**	
B1, B2	Option External switch*	
S1, S2	Option internal/external sensor***	
Pcb Fuses		Rating (A)
F1	T2A (slow blow)	
F2	T3.15A (slow blow)	

4.2 Installer Wiring - Electrically Heated 9 & 12kW THREE PHASE ONLY

The program panel is connected to the base unit via a set of 3 way connectors marked "+12V", "DATA" and "GND". Interconnecting wiring is via screened twisted pair 28AWG as shown. **Max length 50m.** It is recommended that this cable is run separately within its own trunking to avoid external interference.

* **External switch** (ie BMS enable) to be volt free and wired via normally open contacts to terminal pair B1, B2. (Contacts closed to enable). Remove factory fitted jumper J1.

** **Door switch** to be volt free and wired via terminal pair D1 & D2 (Contacts closed to enable door mode) refer section 10.1.3.2 - Door switch mode.

*** **Internal/external sensor** to be wired to terminal pair S1 & S2. refer section 10.1.3.1 - Auto mode.

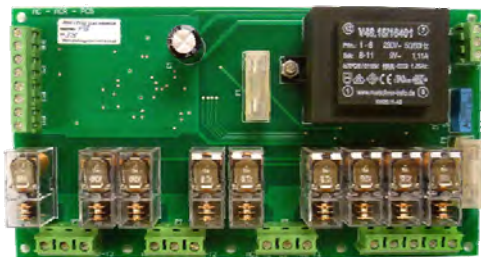
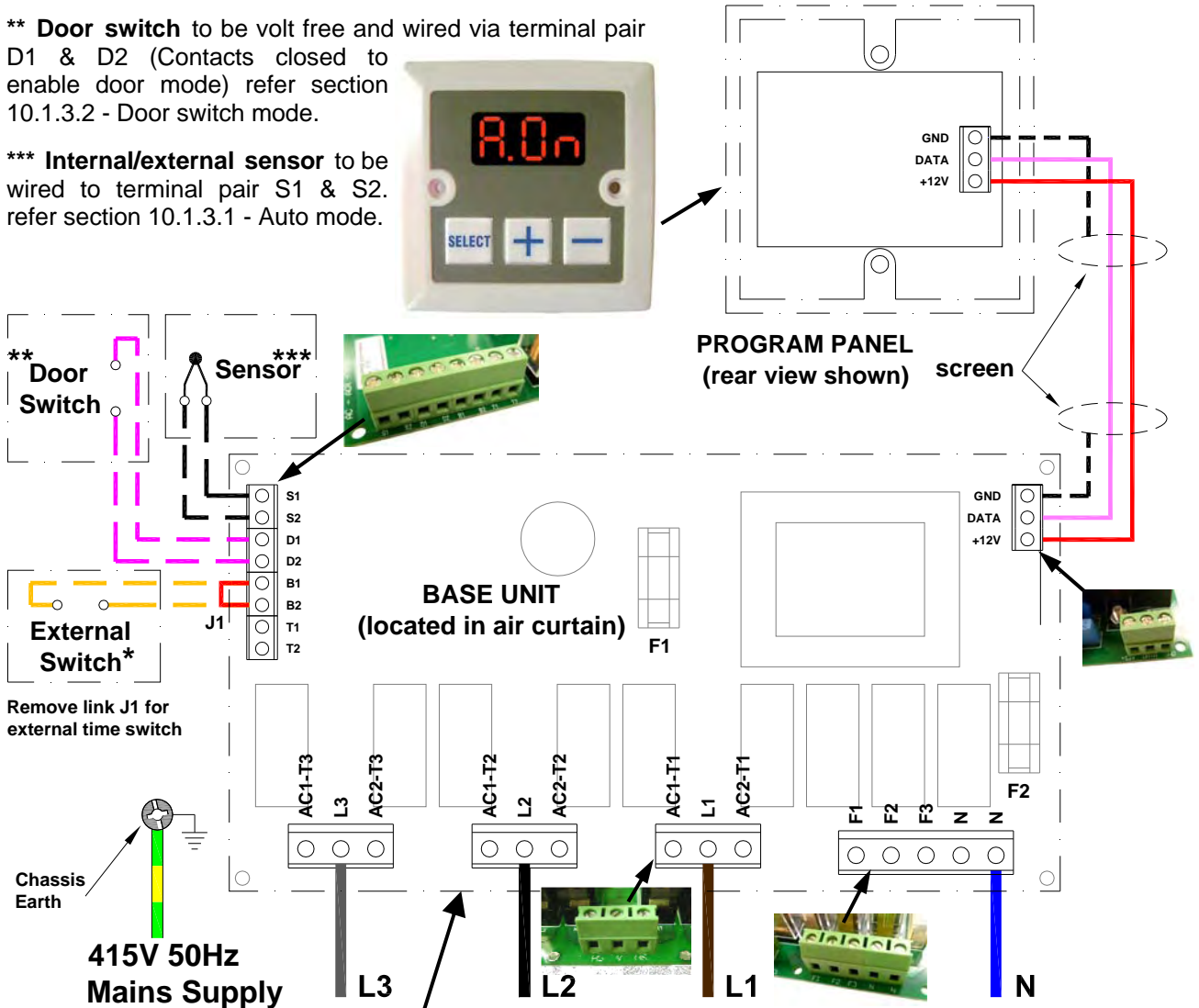

Pcb Terminal	Description	Cable
N	Neutral	4mm ² max
L1	3 phase supply	4mm ² max
L2	3 phase supply	4mm ² max
L3	3 phase supply	4mm ² max
+12V	Supply to remote unit	Cable 1.0mm ² max
DATA	Data to remote unit	
GND(s)	0v Terminal	
D1, D2	option door contact**	
B1, B2	option External switch*	
S1, S2	option internal/external Sensor***	
Pcb Fuses		Rating (A)
F1	T2A (slow blow)	
F2	T3.15A (slow blow)	

Protection

External circuit breaker with the appropriate rating should be installed for the protection of the installation.

4.3 Installer Wiring - Electrically Heated 18kW THREE PHASE ONLY

The program panel is connected to the base unit via a set of 3 way connectors marked "+12V", "DATA" and "GND". Interconnecting wiring is via screened twisted pair 28AWG as shown. **Max length 50m.** It is recommended that this cable is run separately within its own trunking to avoid external interference.

* **External switch** (ie BMS enable) to be volt free and wired via normally open contacts to terminal pair B1, B2. (Contacts closed to enable). Remove factory fitted jumper J1.

** **Door switch** to be volt free and wired via terminal pair D1 & D2 (Contacts closed to enable door mode) refer section 10.1.3.2 - Door switch mode.

*** **Internal/external sensor** to be wired to terminal pair S1 & S2. refer section 10.1.3.1 - Auto mode.

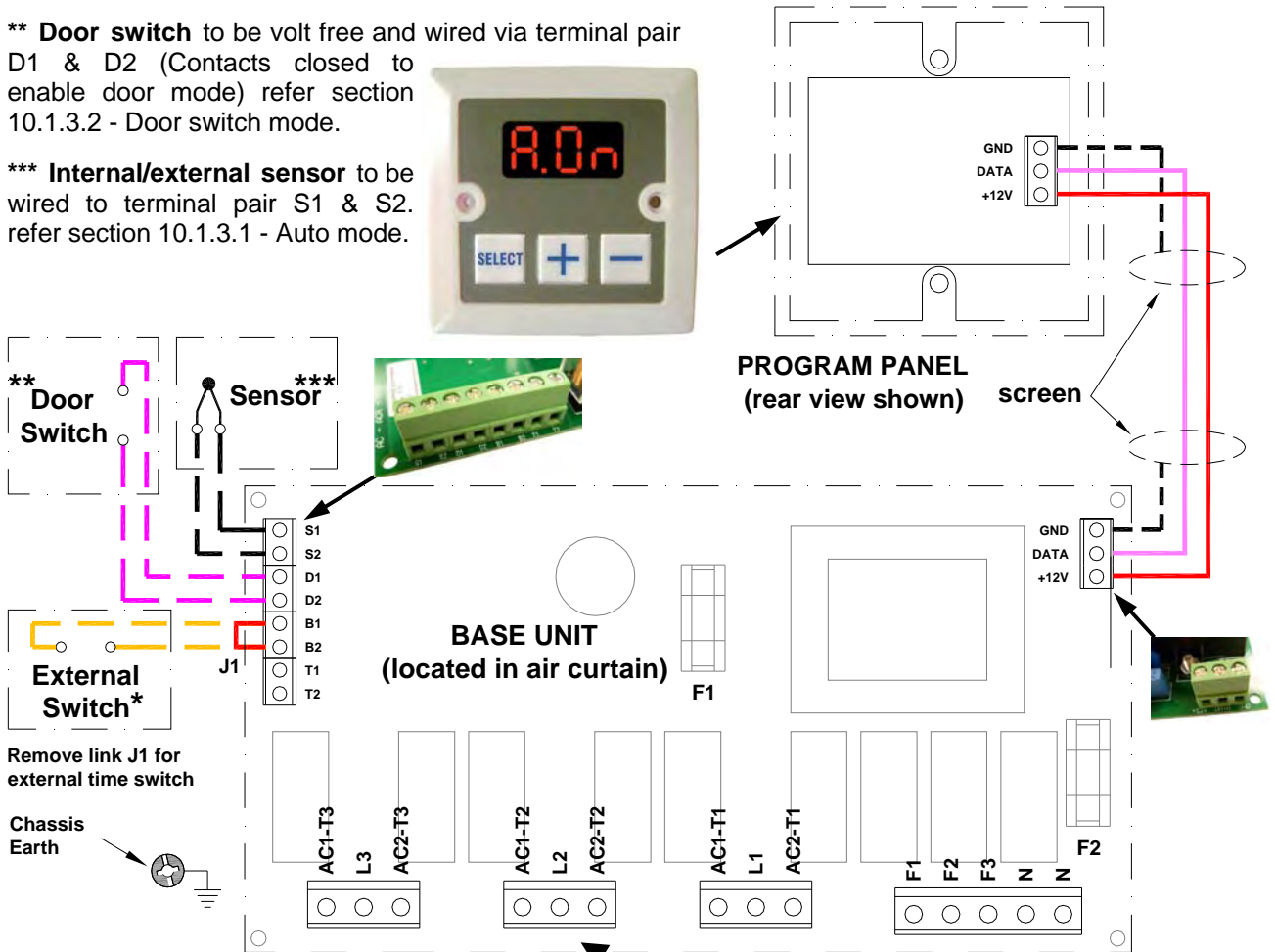

Contractors Terminal

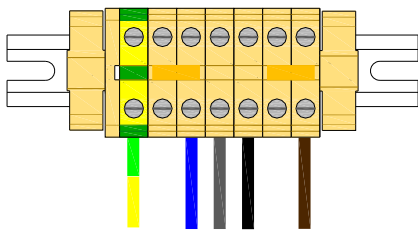

**415V 50Hz
Mains Supply**

Protection

External circuit breaker with the appropriate rating should be installed for the protection of the installation.



Terminal	Description	Cable
N	Neutral	6mm ² max
L1	3 phase supply	6mm ² max
L2	3 phase supply	6mm ² max
L3	3 phase supply	6mm ² max
Pcb Terminal	Description	Cable
+12V	Supply to remote unit	Cable 1.0mm ² max
DATA	Data to remote unit	
GND(s)	0v Terminal	
D1, D2	Option door contact**	
B1, B2	Option External switch*	
S1, S2	Option internal/external sensor***	
Pcb Fuses	Rating (A)	
F1	T2A (slow blow)	
F2	T3.15A (slow blow)	

4.4 Installer Wiring - Ambient

The program panel is connected to the base unit via a set of 3 way connectors marked "+12V", "DATA" and "GND". Interconnecting wiring is via screened twisted pair 28AWG as shown. **Max length 50m.** It is recommended that this cable is run separately within its own trunking to avoid external interference.

* **External switch** (ie BMS enable) to be volt free and wired via normally open contacts to terminal pair B1, B2. (Contacts closed to enable). Remove factory fitted jumper J1.

** **Door switch** to be volt free and wired via terminal pair D1 & D2 (Contacts closed to enable door mode) refer section 10.1.3.2 - Door switch mode.

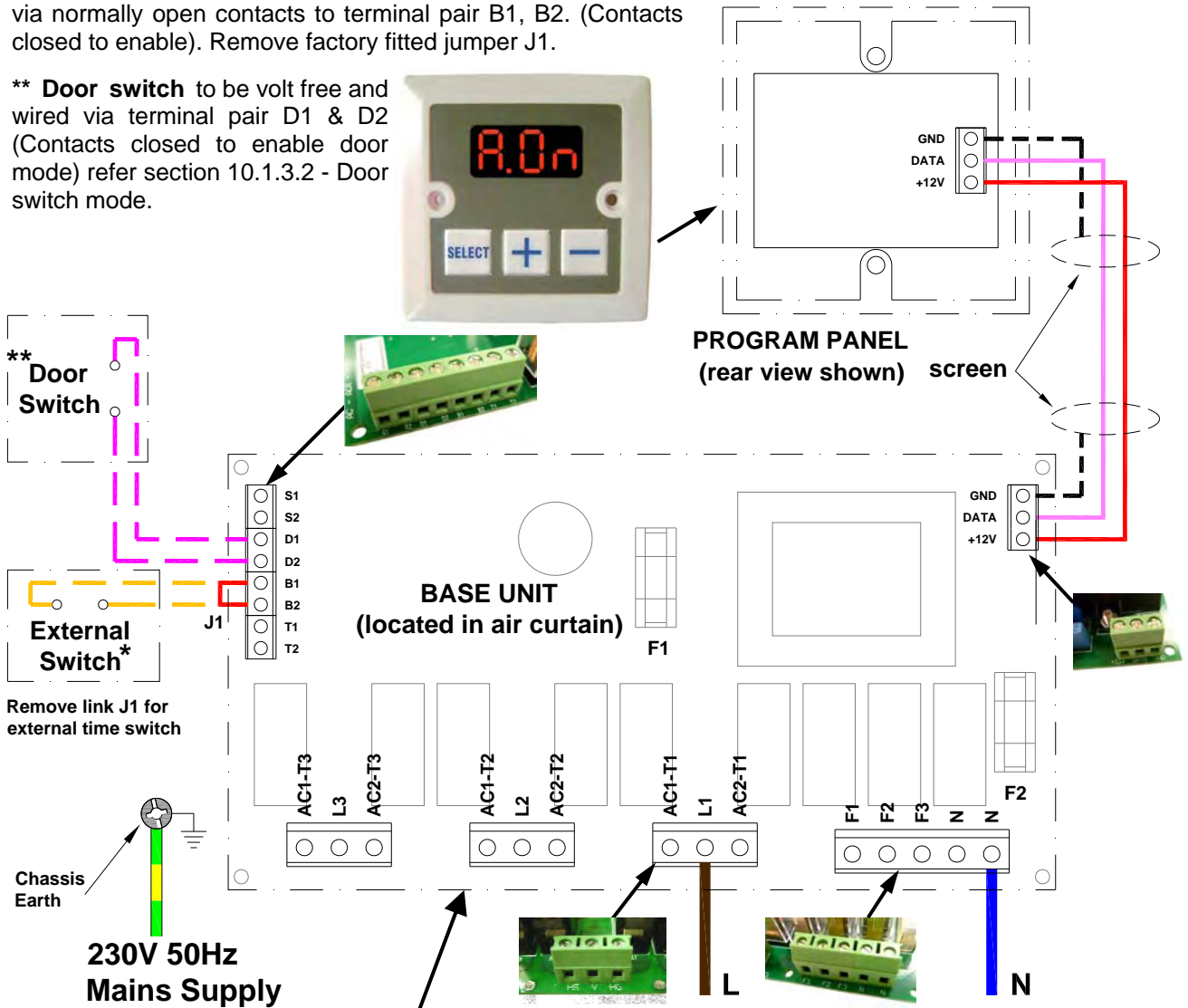

Remove link J1 for external time switch

Chassis Earth

230V 50Hz
Mains Supply



Protection

External circuit breaker with the appropriate rating should be installed for the protection of the installation.

Pcb Terminal	Description	Cable
N	Neutral	4mm ² max
L	1 phase supply	4mm ² max
+12V	Supply to remote unit	Cable 1.0mm ² max
DATA	Data to remote unit	
GND(s)	0v Terminal	
D1, D2	Option door contact**	
B1, B2	Option External switch*	
Pcb Fuses		Rating (A)
F1	T2A (slow blow)	
F2	T3.15A (slow blow)	

4.5 Installer Wiring - LPHW

The program panel is connected to the base unit via a set of 3 way connectors marked "+12V", "DATA" and "GND". Interconnecting wiring is via screened twisted pair 28AWG as shown. **Max length 50m.** It is recommended that this cable is run separately within its own trunking to avoid external interference.

* **External switch** (ie BMS enable) to be volt free and wired via normally open contacts to terminal pair B1, B2. (Contacts closed to enable). Remove factory fitted jumper J1.

** **Door switch** to be volt free and wired via terminal pair D1 & D2 (Contacts closed to enable door mode) refer section 10.1.3.2 - Door Link.

*** **Internal/external sensor** to be wired to terminal pair S1 & S2. refer section 10.1.3.1 - Auto mode.

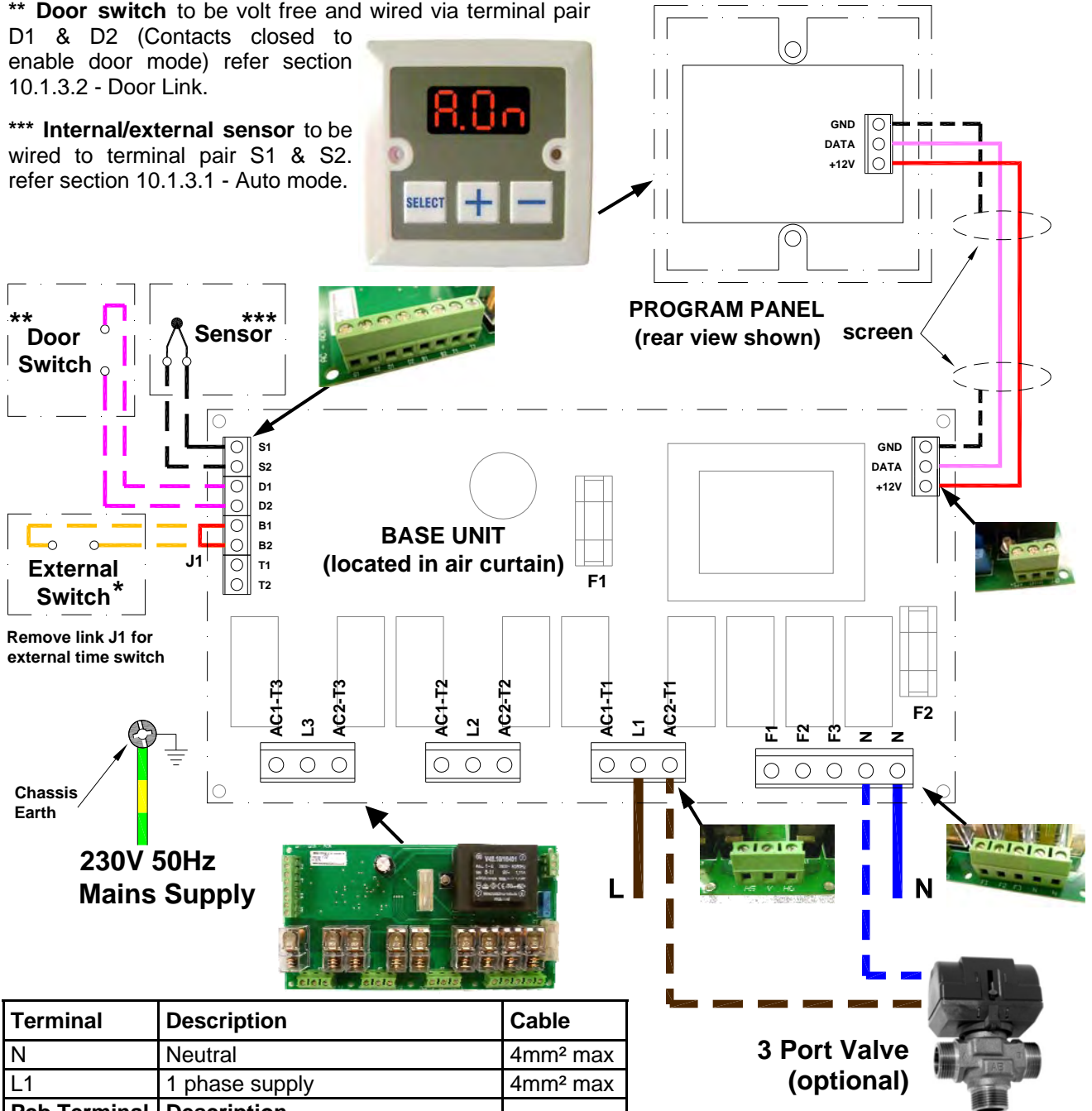

Terminal	Description	Cable
N	Neutral	4mm ² max
L1	1 phase supply	4mm ² max
Pcb Terminal	Description	Cable 1.0mm ² max
12V	Supply to remote unit	
DATA	Data to remote unit	
GND(s)	0v Terminal	
D1, D2	Option door contact**	
B1, B2	Option External switch*	
S1, S2	Option internal/external sensor***	
Pcb Fuses	Rating (A)	
F1	T2A (slow blow)	
F2	T3.15A (slow blow)	

Optional 3 port valve to be wired to terminals AC1T1 and N.

Protection

External circuit breaker with the appropriate rating should be installed for the protection of the installation.

4.6 Factory Wiring - Electrically heated ACR100/ACR150 6 & 9kW 1Ph ONLY

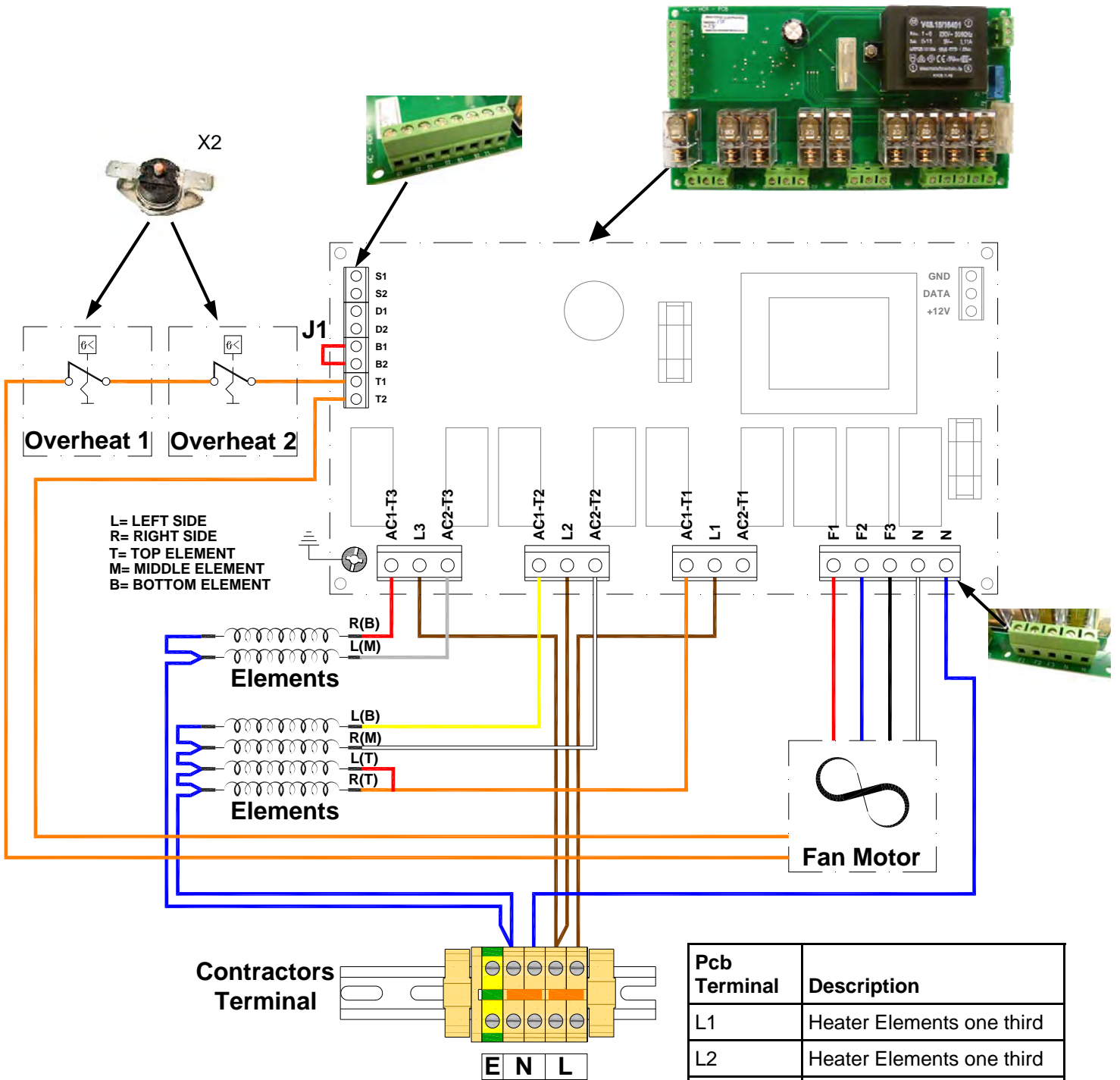

The element output is connected to the right and left side of each terminal block marked "AC1-T1", "AC2-T1", "AC1-T2", "AC2-T2", "AC1-T3" and "AC2-T3"

The fan output is connected to a 4 way connector marked "N", "F1", "F2" and "F3".

The thermal trip is connected to a 2 way connector marked "T1" & "T2"

4.7 Factory Wiring - Electrically heated ACR200 9kW 1Ph ONLY

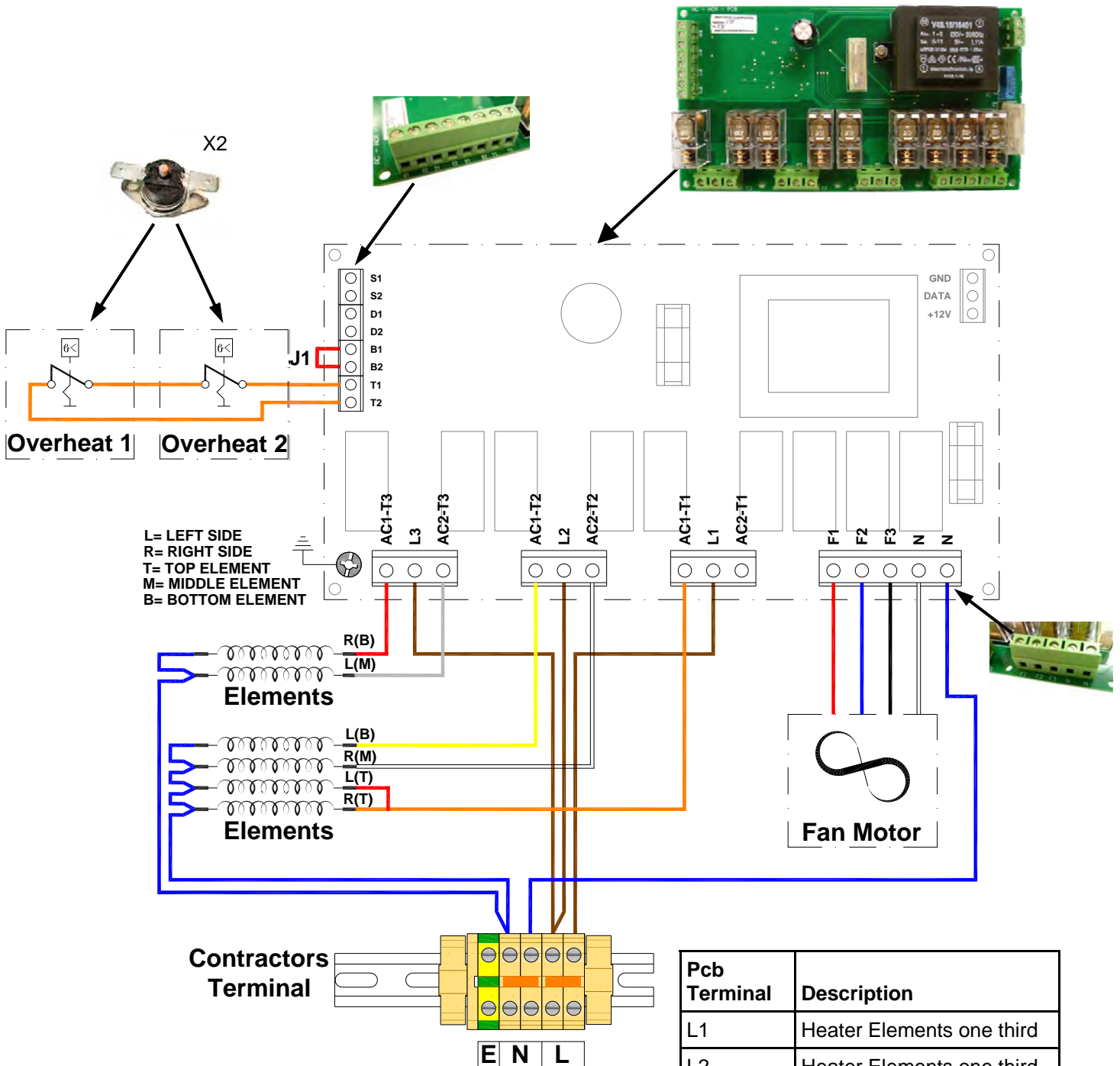

The element output is connected to the right and left side of each terminal block marked "AC1-T1", "AC2-T1", AC1-T2", "AC2-T2", "AC1-T3" and "AC2-T3"

The fan output is connected to a 4 way connector marked "N", "F1", "F2" and "F3".

The thermal trip is connected to a 2 way connector marked "T1" & "T2"

4.8 Factory Wiring - Electrically heated ACR100/ACR150 9 & 12kW 3Ph

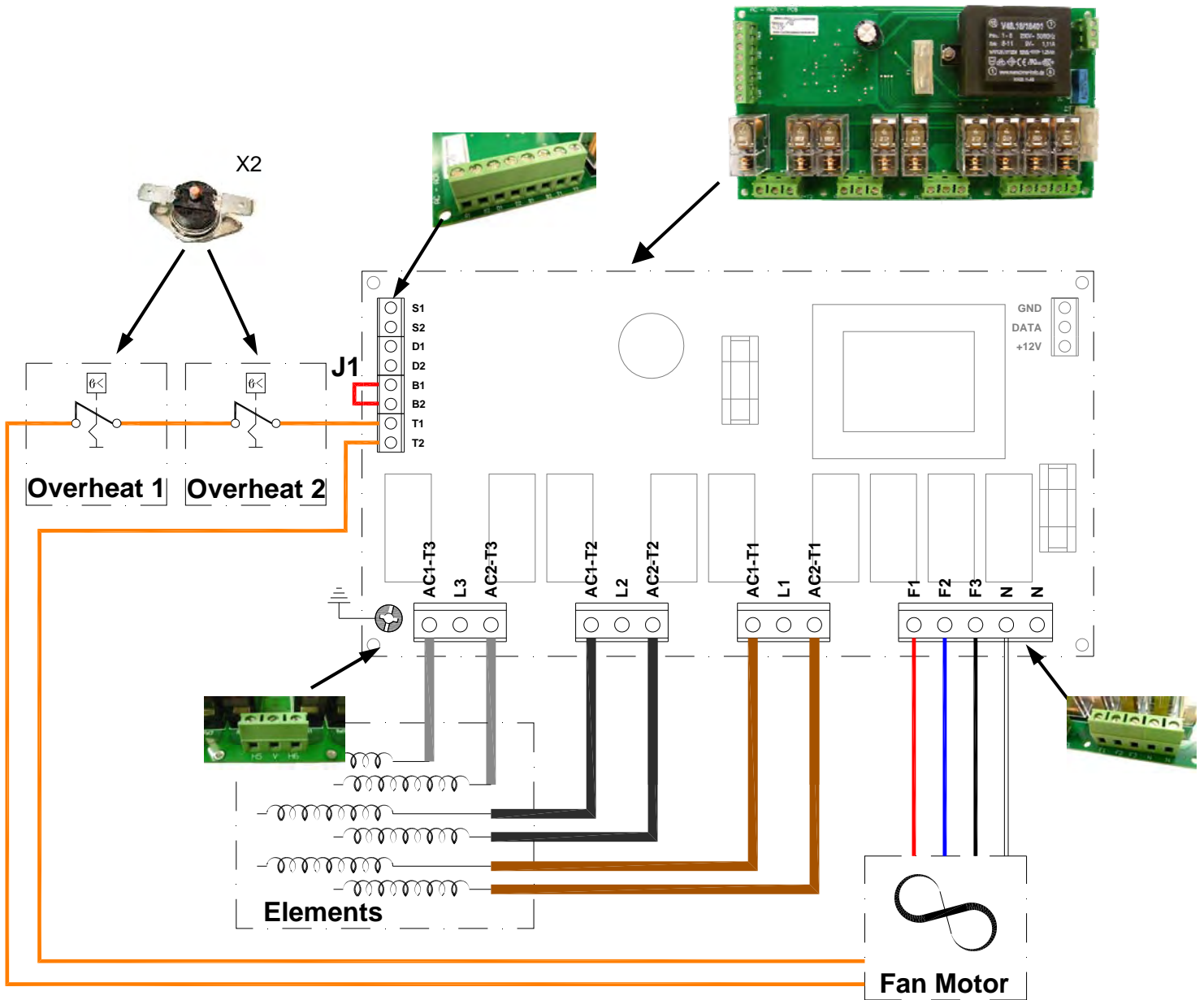

Pcb Terminal	Description
L1	Heater Elements phase 1
L2	Heater Elements phase 2
L3	Heater Elements phase 3
N	Neutral to fan
F1	Fan - low speed
F2	Fan - medium speed
F3	Fan - high speed
T1	Thermal Overheat trip
T2	Thermal Overheat trip
J1	Factory BMS link

The element output is connected to the right and left side of each terminal block marked "AC1-T1", "AC2-T1", "AC1-T2", "AC2-T2", "AC1-T3" and "AC2-T3"

The fan output is connected to a 4 way connector marked "N", "F1", "F2" and "F3".

The thermal trip is connected to a 2 way connector marked "T1" & "T2"

4.9 Factory Wiring - Electrically heated ACR120HE 12kW 3Pha

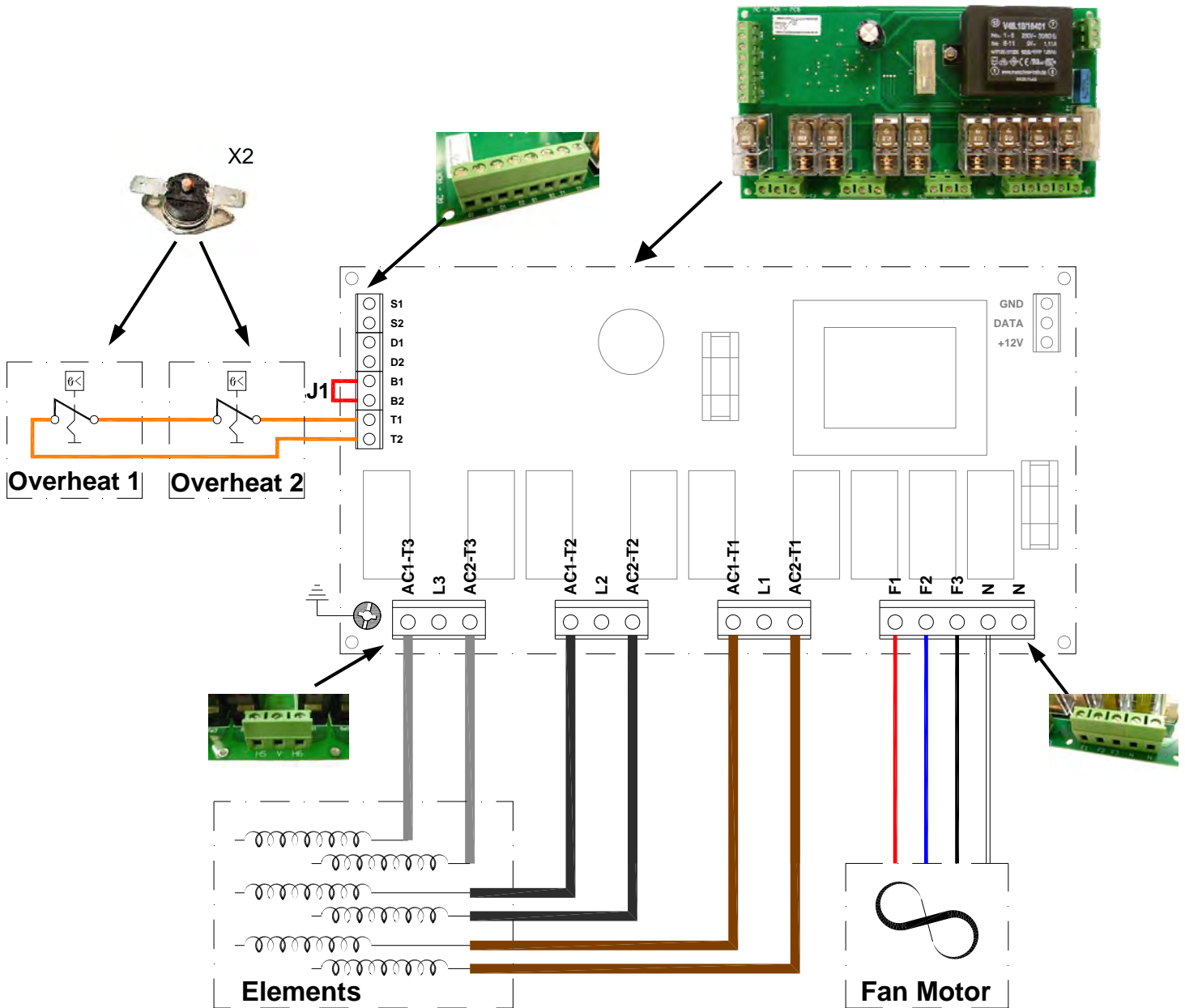

Pcb Terminal	Description
L1	Heater Elements phase 1
L2	Heater Elements phase 2
L3	Heater Elements phase 3
N	Neutral to fan
F1	Fan - low speed
F2	Fan - medium speed
F3	Fan - high speed
T1	Thermal Overheat trip
T2	Thermal Overheat trip
J1	Factory BMS link

The element output is connected to the right and left side of each terminal block marked "AC1-T1", "AC2-T1", "AC1-T2", "AC2-T2", "AC1-T3" and "AC2-T3"

The fan output is connected to a 4 way connector marked "N", "F1", "F2" and "F3".

The thermal trip is connected to a 2 way connector marked "T1" & "T2"

4.10 Factory Wiring - Electrically heated ACR200/ACR180HE 18kW 3Pha

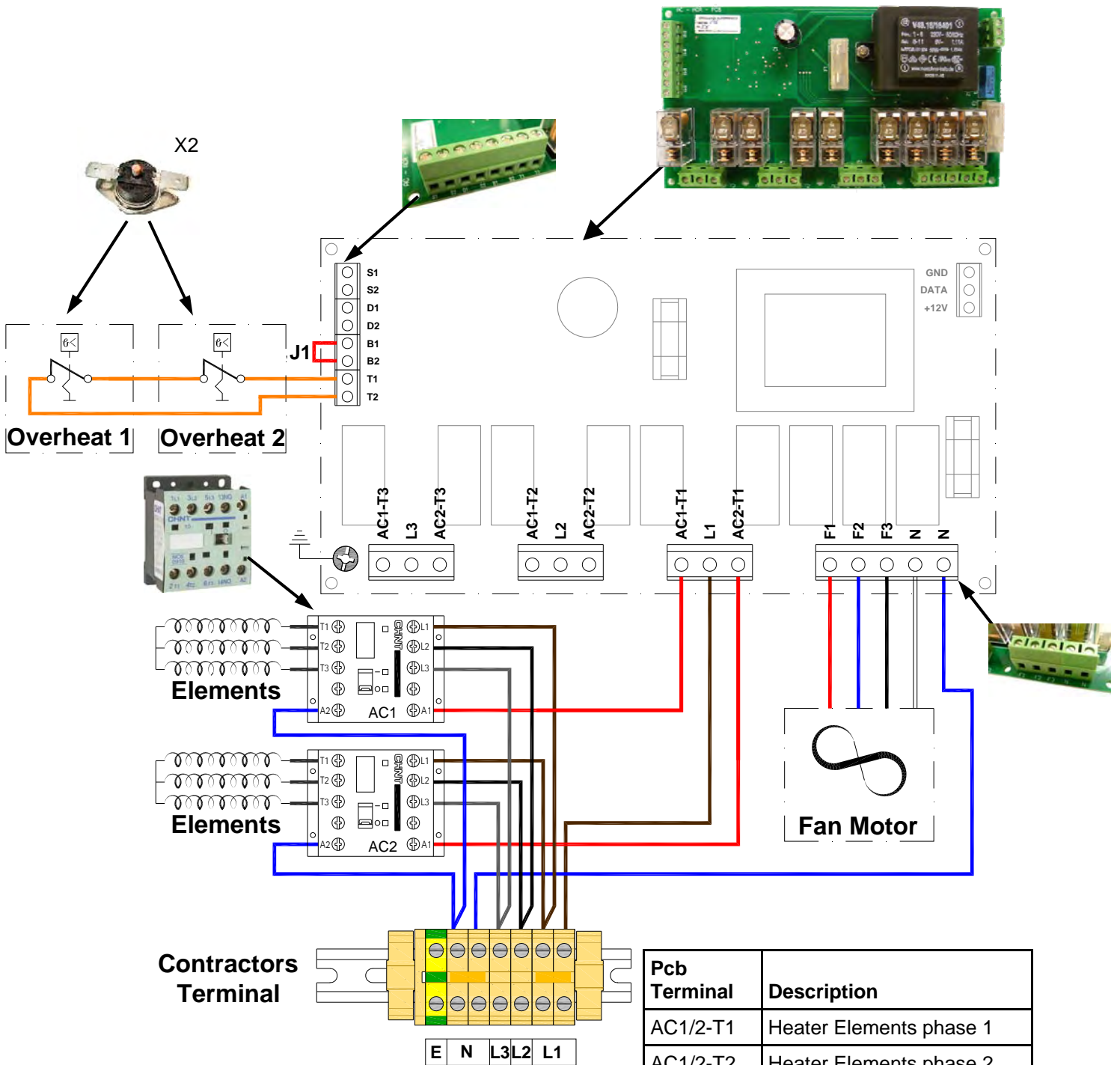

The element outputs are connected to contactors "AC1" and "AC2" on terminals T1, T2 and T3.

The fan output is connected to a 4 way connector marked "N", "F1", "F2" and "F3".

The thermal trip is connected to a 2 way connector marked "T1" & "T2"

4.11 Factory Wiring - Ambient ACR100/ACR150

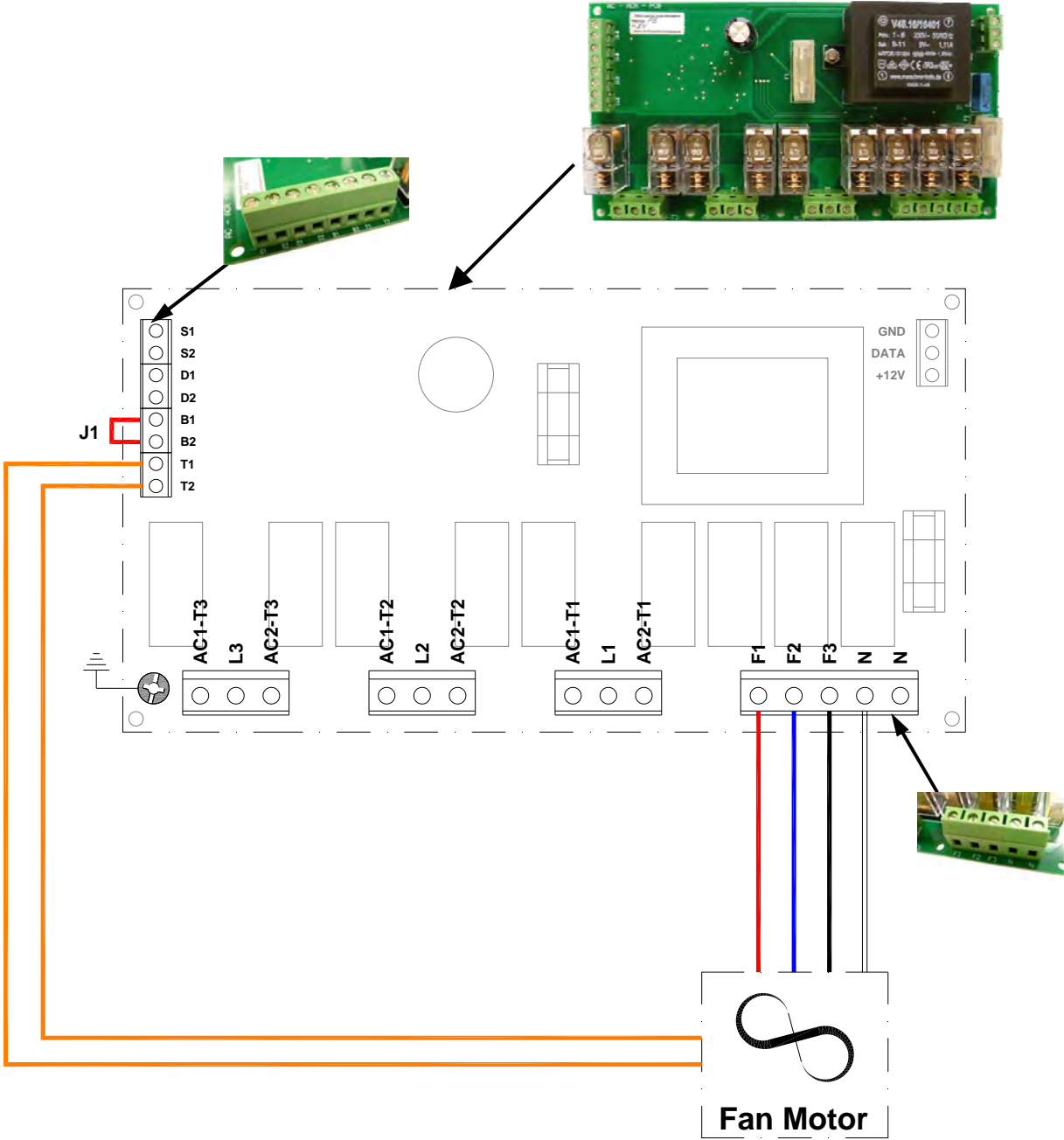

Pcb Terminal	Description
N	Neutral to fan
F1	Fan - low speed
F2	Fan - medium speed
F3	Fan - high speed
J1	Factory BMS link

The fan output is connected to a 4 way connector marked "N", "F1", "F2" and "F3".

4.12 Factory Wiring - Ambient ACR200/ACR120HA/ACR180HA

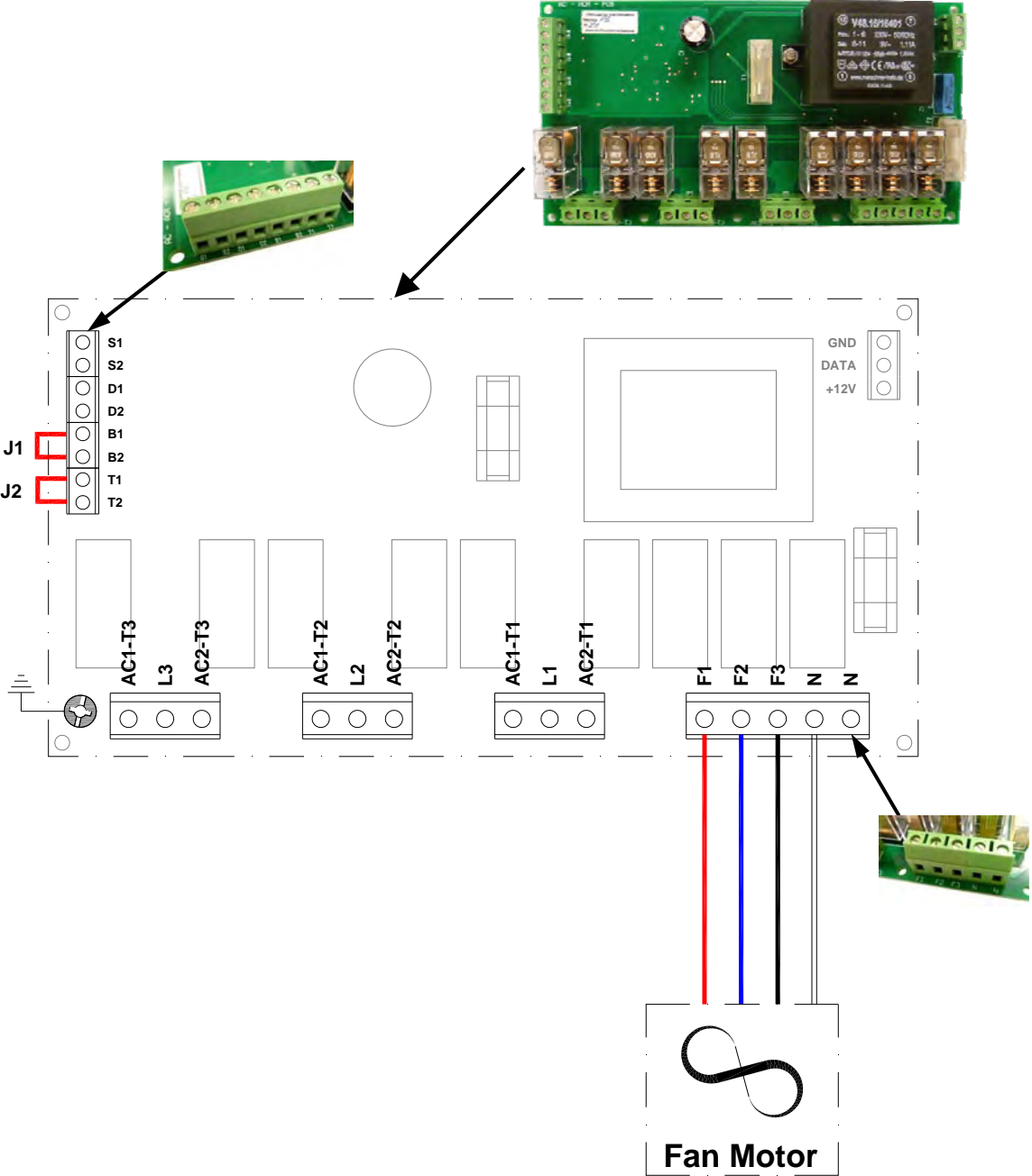

Pcb Terminal	Description
N	Neutral to fan
F1	Fan - low speed
F2	Fan - medium speed
F3	Fan - high speed
J1	Factory BMS link
J2	Factory thermal link

The fan output is connected to a 4 way connector marked "N", "F1", "F2" and "F3".

4.13 Factory Wiring - LPHW ACR100/ACR150

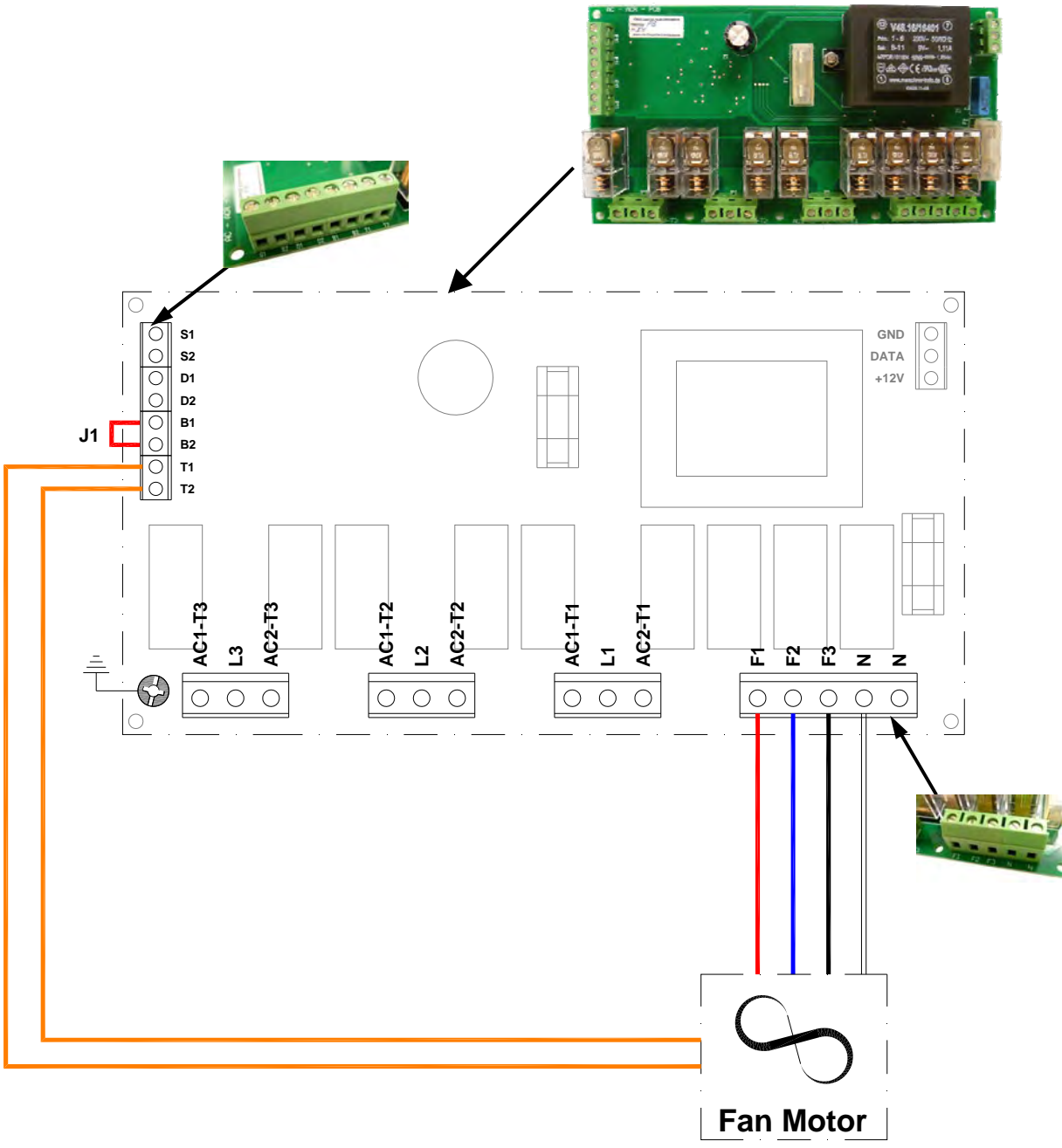

Pcb Terminal	Description
N	Neutral to fan
F1	Fan - low speed
F2	Fan - medium speed
F3	Fan - high speed
J1	Factory BMS link

The fan output is connected to a 4 way connector marked "N", "F1", "F2" and "F3".

4.14 Factory Wiring - LPHW ACR200/ACR120HW/ACR180HW

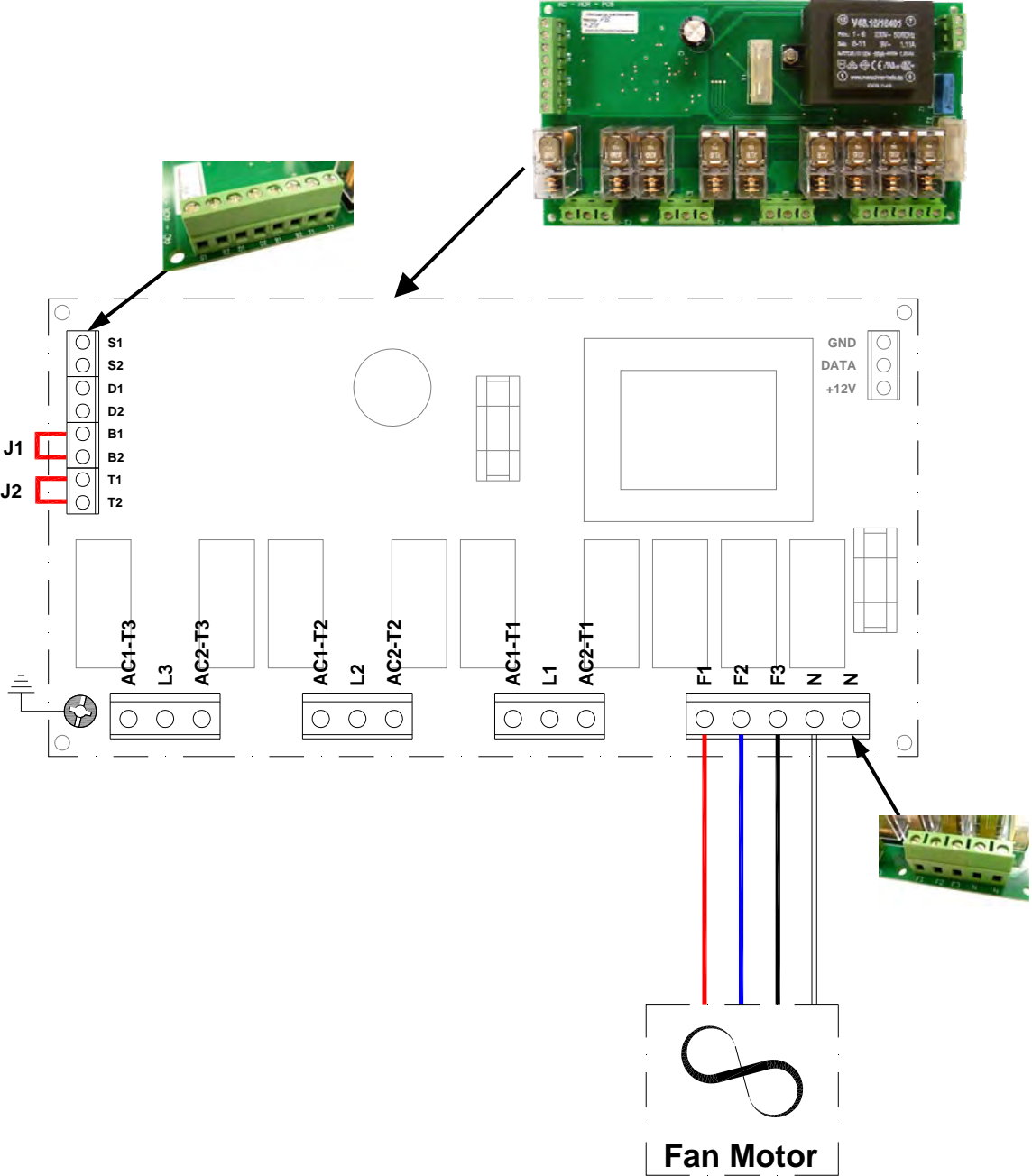

Pcb Terminal	Description
N	Neutral to fan
F1	Fan - low speed
F2	Fan - medium speed
F3	Fan - high speed
J1	Factory BMS link
J2	Factory thermal link

The fan output is connected to a 4 way connector marked "N", "F1", "F2" and "F3".

4.15 Network Wiring - Electronic controller

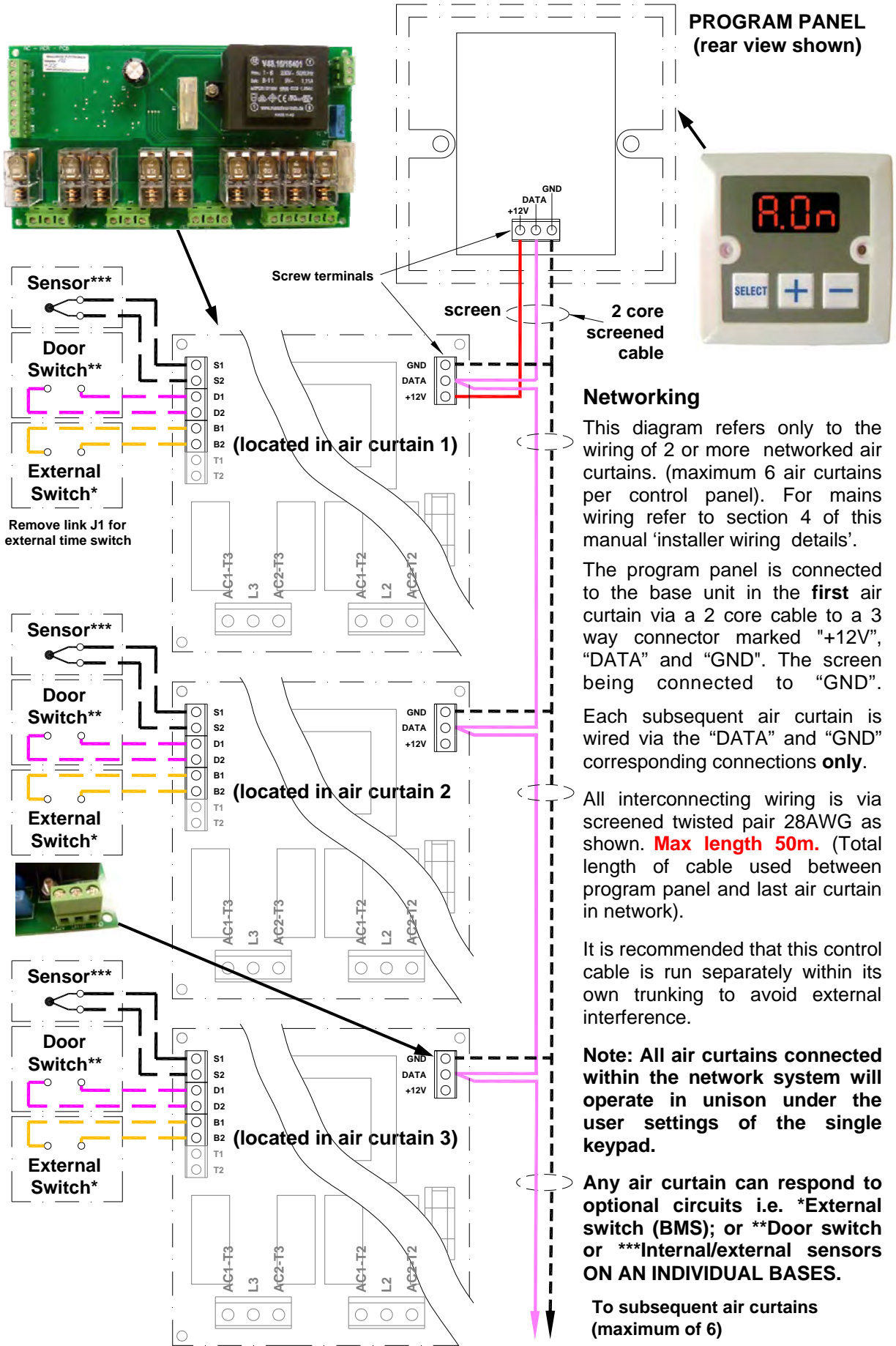

4.16 Installer wiring diagram Electrically heated with SmartElec2 control.

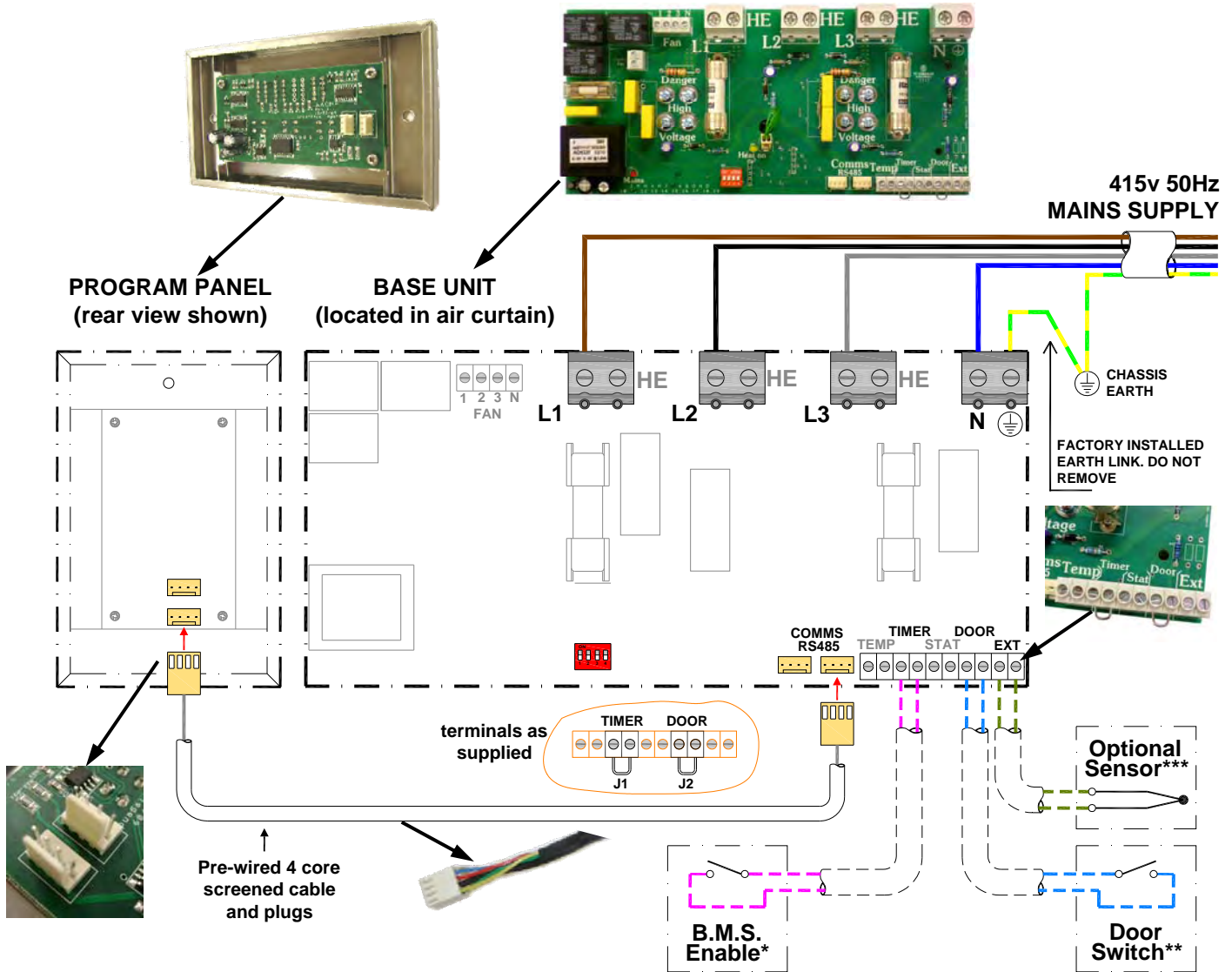

Interconnecting wiring

The program panel is connected to the base unit via a set of pre-wired 4 core screened cables with pre-wired plugs as shown.

Interconnecting wiring is via a 4 core screened cable with pre-wired plugs, supplied in 2, 10, 20, 30, 50 and 100m lengths.

It is recommended that this control cable is run separately within its own trunking to avoid external interference.

Optional wiring

* **External switch** (ie BMS enable) to be volt free and wired via normally open contacts to terminal pair 'TIMER'. (Contacts closed to enable). Remove factory fitted jumper J1.

** **Door switch** to be volt free and wired via normally closed contacts to terminal pair 'DOOR'. (Contacts open to enable door mode). Remove factory fitted jumper J2. refer section 10.2.6.1 - Door link settings.

*** **Internal/external sensor** to be wired to terminal pair 'EXT'. refer section 10.2.6.4 - External Temperature.

Protection

There are two high speed fuses on the base unit to protect the switching thyristors for the heater. An external circuit breaker with the appropriate rating should be installed for the protection of the installation.

Terminal	Description	Cable
N	Neutral	10mm ² max
L1	3 phase supply	10mm ² max
L2	3 phase supply	10mm ² max
L3	3 phase supply	10mm ² max
E	Mains earth	10mm ² max
Timer*	BMS pair (volt -free)	1.5mm ² max
Door**	Door interlock pair, n.c. (volt free)	1.5mm ² max
Ext***	External sensor pair (non-polarised)	1.5mm ² max

4.17 Factory Installed Wiring. Electrically Heated ACR100/ACR150 with SmartElec2 Control.

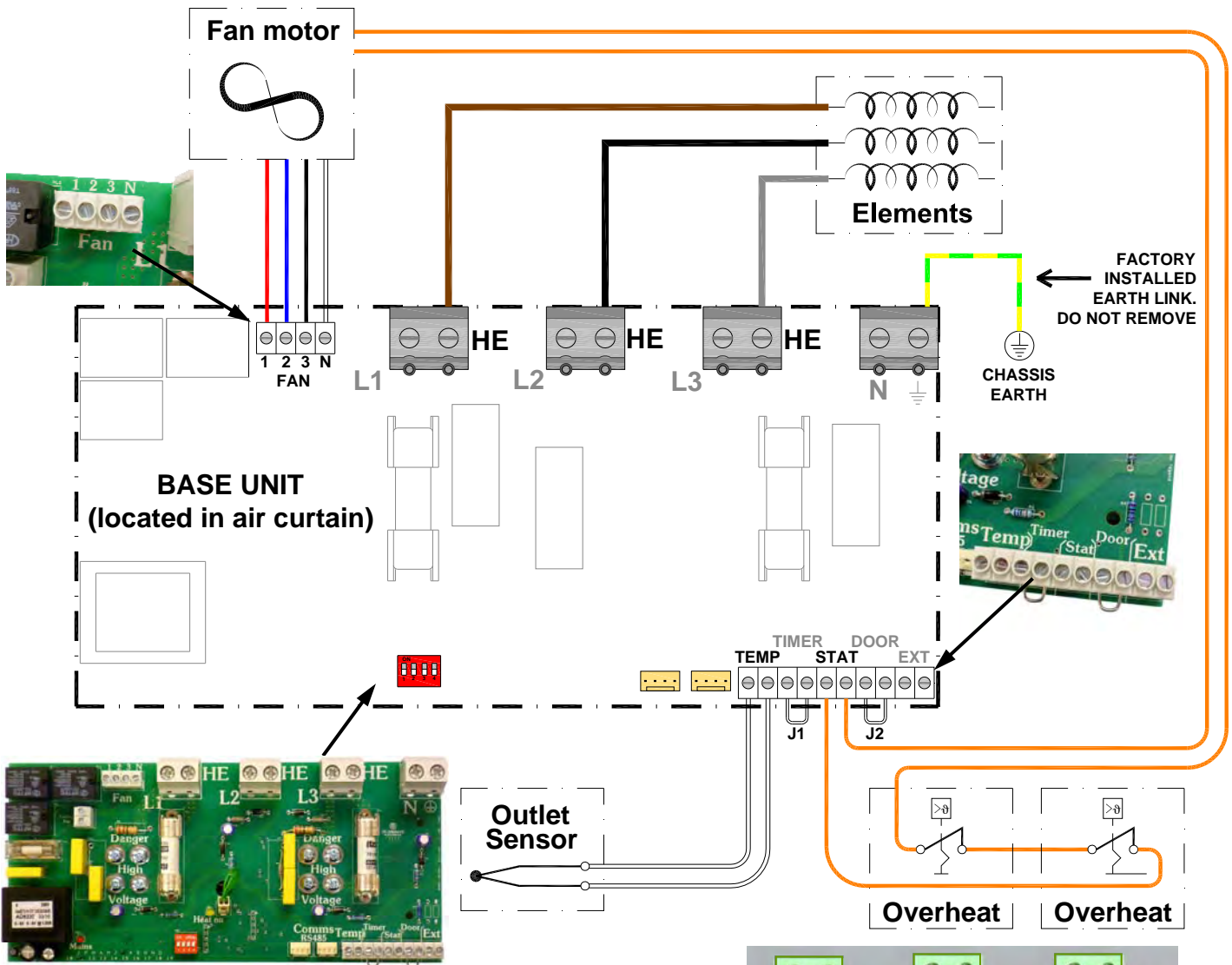

Terminal	Description	Cable
HE	Heating elements phase 1	10mm ² max
HE	Heating elements phase 2	10mm ² max
HE	Heating elements phase 3	10mm ² max
N	Neutral to fan	1.5mm ² max
1	Fan - low speed	1.5mm ² max
2	Fan - medium speed	1.5mm ² max
3	Fan - high speed	1.5mm ² max
Temp	Air sensor pair (non-polarised)	1.5mm ² max
Stat	Ext thermal trip pair, n.c. (volt-free)	1.5mm ² max
Comms	Keypad/network connectors	Pre-wired

The heater element outputs are connected to the right hand side of three terminal blocks and are marked 'HE'. (See below).

The fan output is connected to a 4 way terminal block marked 'N, 1, 2 and 3'.

The sensor input (air sensor) is connected to 2 terminals marked 'TEMP' on the base unit. The sensor is not polarity sensitive.

The external thermal trip (volt-free) is connected to 2 terminals marked 'STAT' on the base unit. The terminals are not polarity sensitive.

4.18 Factory Installed Wiring. Electrically Heated ACR200/ACR120HE/ACR180HE with SmartElec2.

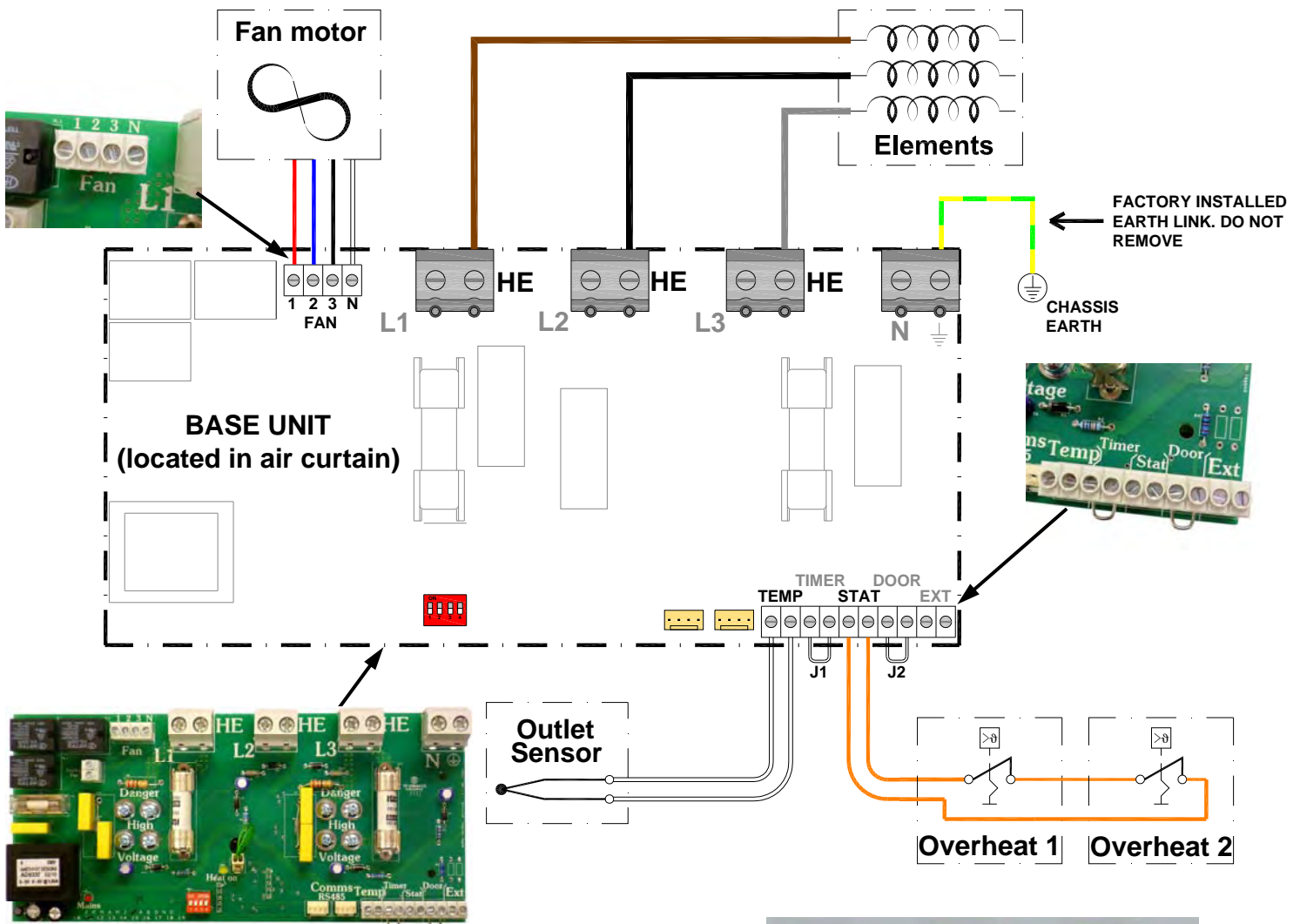

Terminal	Description	Cable
HE	Heating elements phase 1	10mm ² max
HE	Heating elements phase 2	10mm ² max
HE	Heating elements phase 3	10mm ² max
N	Neutral to fan	1.5mm ² max
1	Fan - low speed	1.5mm ² max
2	Fan - medium speed	1.5mm ² max
3	Fan - high speed	1.5mm ² max
Temp	Air sensor pair (non-polarised)	1.5mm ² max
Stat	Ext thermal trip pair, n.c. (volt-free)	1.5mm ² max
Comms	Keypad/network connectors	Pre-wired

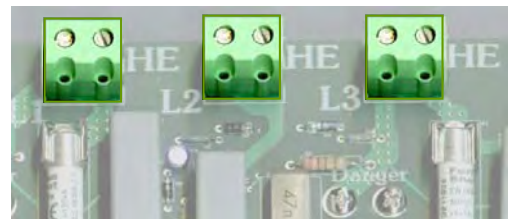

The heater element outputs are connected to the right hand side of three terminal blocks and are marked 'HE'. (See below).

The fan output is connected to a 4 way terminal block marked 'N, 1, 2 and 3'.

The sensor input (air sensor) is connected to 2 terminals marked 'TEMP' on the base unit. The sensor is not polarity sensitive.

The external thermal trip (volt-free) is connected to 2 terminals marked 'STAT' on the base unit. The terminals are not polarity sensitive.

4.19 Network Wiring Electrically Heated with SmartElec2 Control.

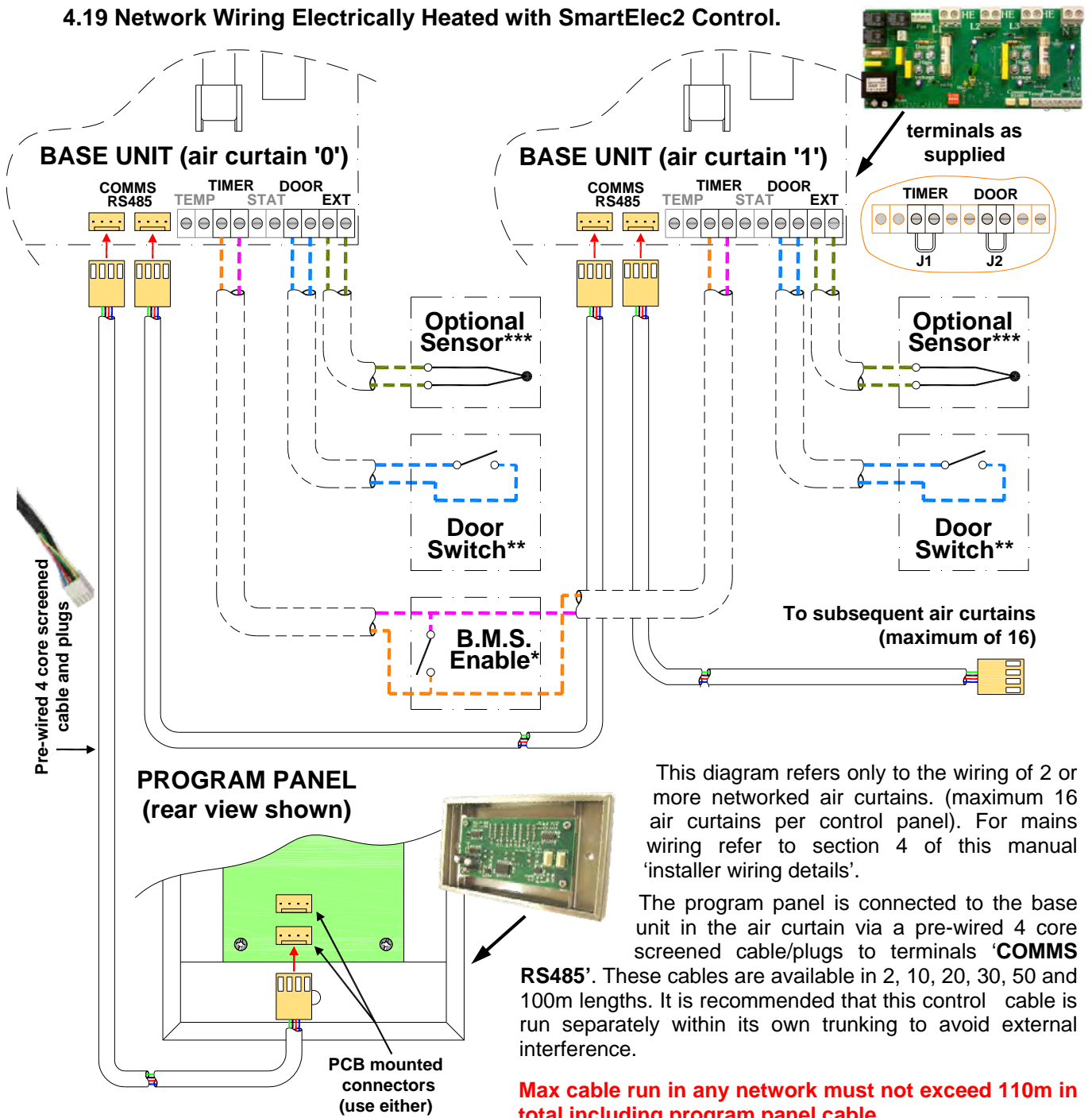

Note: All air curtains connected within the network system will operate under the settings of the single keypad.

Any air curtain within the network can be connected with and respond to the following optional circuits:

* **External switch** (ie BMS enable) where required, to be volt free and wired **in PARALLEL** via normally open contacts to each terminal pair 'TIMER'. (Contacts closed to enable). Only air curtain(s) wired this way will respond to the enable signal. Remove factory fitted jumpers J1. (**NOTE: terminals are polarity sensitive**)

** **Door switches** where required, to be volt free and wired to **INDIVIDUAL** base units via normally closed contacts to each terminal pair 'DOOR'. (Contacts open to enable door mode). Only air curtain(s) wired this way will respond to the door mode. Remove factory fitted jumper J2. refer section 10.2.6.1 - Door link settings.

*** **Internal/external sensors**, where required, to be wired to **INDIVIDUAL** base units to each terminal pair 'EXT'. Only air curtain(s) wired this way will respond to the sensor setting. If a sensor is fitted to more than one air curtain then the value is displayed as an average. refer section 10.2.6.4 - External temperature.

5. Installation Details.

5.1 Mounting

Airbloc units should be installed horizontally directly over the door opening. They are designed for discreet positioning in a suspended ceiling or bulkhead in the doorways of retail or commercial premises. The unit can also be mounted within an optional case for doorways with restricted space or no suspended ceiling or bulkhead.

Care must be taken to allow complete free air movement into the inlet grilles of the unit to ensure correct working operation of the air curtain. The discharge opening should be as close to the top of the door as possible and to cover the entire door width.

Units can be mounted adjacent to each other to cover the full door opening across wider entrances.

5.2 Electrical Supply.

These units are suitable for connection to a 415 Volt, 50Hz 3 phase and neutral supply for Electrically heated 9-18kW models or 230/240 Volt 50 Hz single phase supply for Electrically heated 6kW, 9kW, Ambient and LPHW models.

Electrically heated models consume 6kW and 9kW at 230 volts and 9kW, 12kW & 18kW at 415 volts when switched to the full heat position depending on their model and capacity size.

The appliance shall be connected to the supply via an appropriate switched fused double pole isolator having a contact separation of greater than 3mm. Test for correct operation and refit the cover.

For connection to the mains supply it will be necessary to open the hinged lid from the unit. The base unit is located on a base plate. It will be necessary to connect the mains supply and the lead from the remote key pad prior to refitting the cover. Wire in accordance to diagrams in section 4.1 to 4.5

For optional SmartElec2 controller, wire as shown in diagrams 4.16 to 4.18

 For safety reasons, a sound earth connection must always be made to the unit before it is put to use. The unit should be wired in accordance with IEE Regulations for the Electrical Equipment of Buildings.

5.3 Installation.

It is the sole responsibility of the installer to ensure that the points of attachment to the building are sound. Consultation with the consultant/architect or owner of the building is recommended to ensure that a sound, mechanically stable installation is achieved.

All attachments must be capable of supporting the weight of the product detailed in Section 3.

Step 1

Before fitting or wiring the air curtain, ensure casing faces as below and see general installation guidance notes.

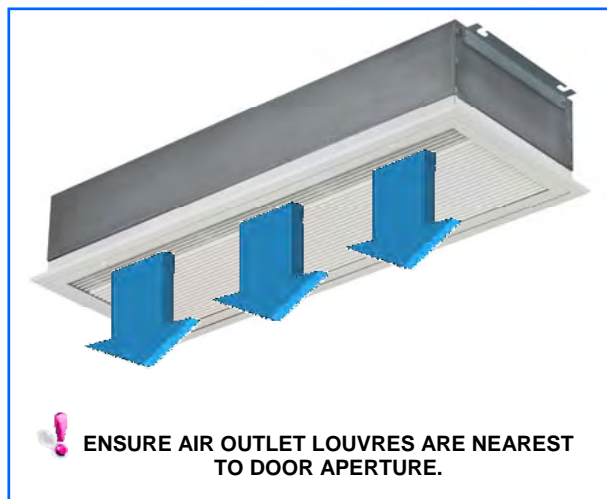

Step 2

Using a 4mm Allen key slacken the captive M6 Allen screws at the side of the grille.

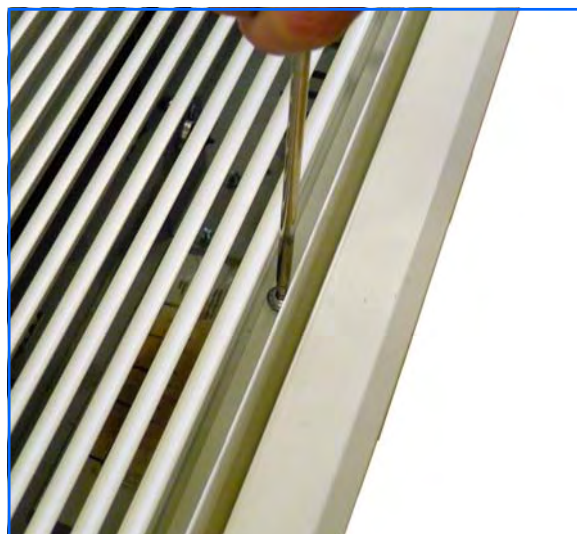

Step 3

Access to the inside of the air curtain grille can be made. Open the grille. The grille is hinged to prevent the inner frame from dropping.

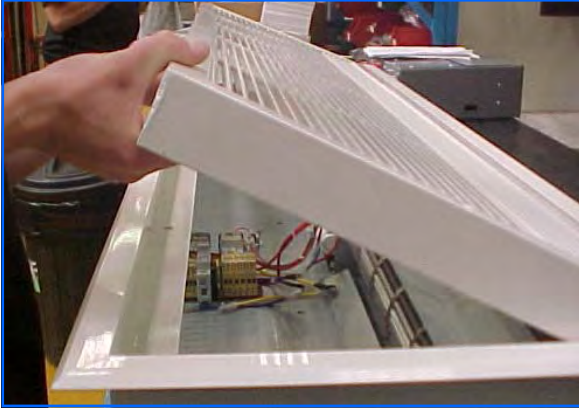

Step 4

The grille assembly can now be removed from the case to allow fitting of the product in the ceiling recess. Remove the screws from the outer frame to the top of the product case.



Step 5

Attachment of the air curtain to the ceiling structure is by means of the two brackets attached to the side of the air curtain. The brackets may be removed to assist in passing the air curtain through the recess then reattached when in-situ.



Step 6

Either drop rods or catenary wire (available from manufacturer) can be used to fasten the air curtain to the ceiling support structure.

Note When using drop rods the casing mounting brackets are slotted and the mounting plates provided must be used on assembly.

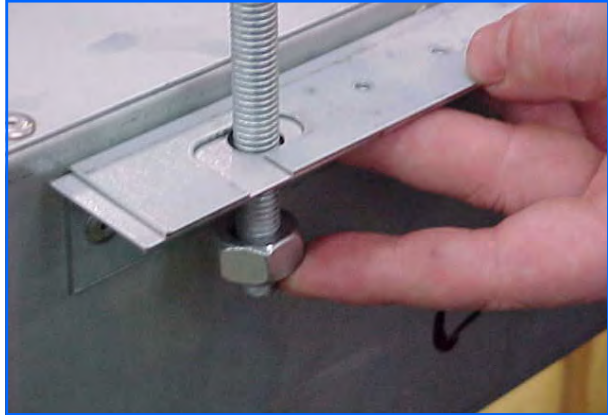

Step 7

The height between the ceiling face and the face of the air curtain case needs to be adjusted to circa 40mm to enable the grille assembly to fit flush with the ceiling. Adjust accordingly.

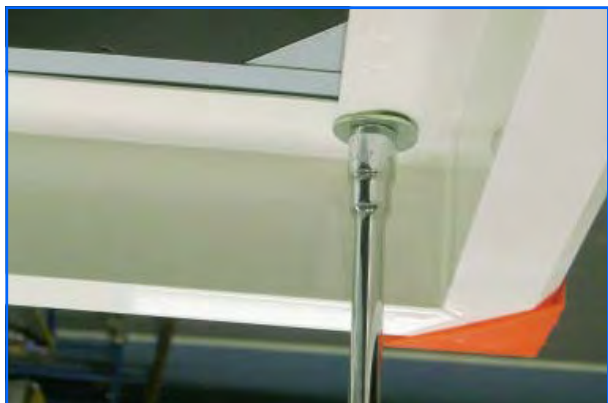

After fitting the product in the ceiling recess and adjusting the height to ensure that the grille sits flush to the ceiling (when re-fitted) take the grille assembly and refit using the screws removed during Step 5.

5.4 Installation details - AC-ACR-PANEL programmer

The Electronic base unit is pre-installed inside the air curtain. All the external electrical connections are via screw terminals onto this base unit.

The program keypad is installed on a separate fascia plate and connected to a surface mounted back box in a suitable location. Please see fig 5.

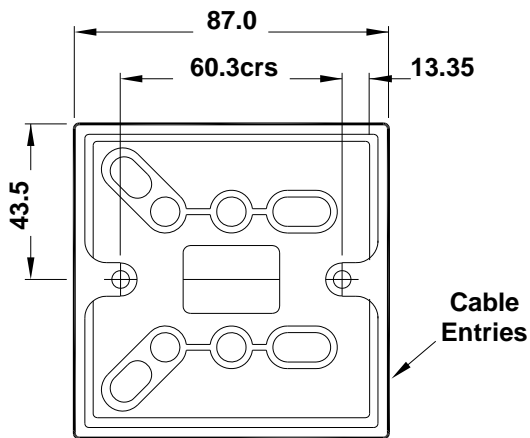

Fig. 5. Surface mount location holes.

Alternatively, the program panel can be flush wall mounted with the addition of a suitable conduit box MK part number 861 ZIC or equivalent.

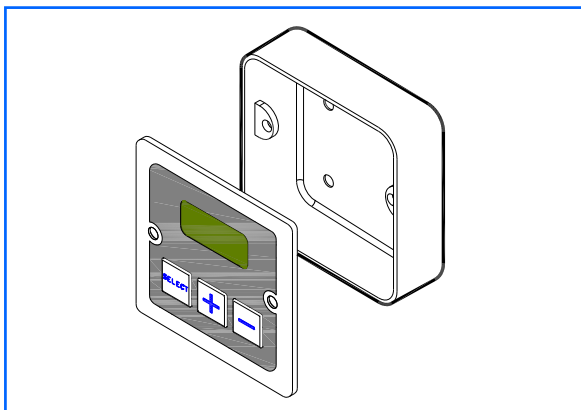

Fig. 6. Alternative conduit box

The distance between the base unit and the program panel can be up to 50m maximum.

5.5 Installation details - Option SmartElec2 Controller

The SmartElec2 base unit is pre-installed inside the air curtain. All the external electrical connections are via screw terminals onto this base unit.

The SmartElec2 program panel is installed in a separate housing and connected to a surface mounted back box in a suitable location. Please see fig 7.

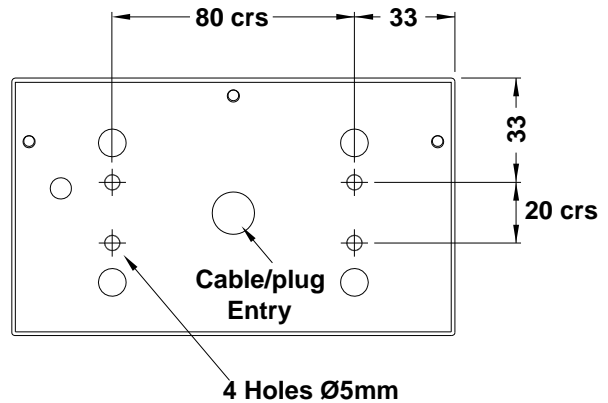

Fig. 7. Surface mount location holes.

Alternatively, the program panel can be flush wall mounted with the addition of a suitable conduit box MK part number 892 ALM or equivalent.

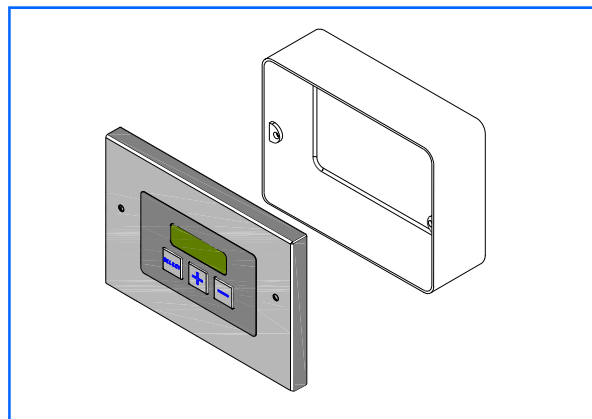

Fig. 8. Alternative conduit box

The distance between the base unit and the program panel can be up to 100m maximum.

5.6 Installation details - LPHW Only

To avoid risk of transit damage to the flow and return connections, **ON LPHW STANDARD CAPACITY ONLY** the heating coil is provided loose inside the case together with the air deflector plate and side supports. **NOTE: HIGH CAPACITY LPHW COILS ARE PRE-FITTED.**

To install, unpack the loose items and identify the two side supports as shown below and fit to the inner side of the case using the screws provided.
Note The side supports are handed.

The coils **can be handed for right or left hand** exit by turning the coil through 180°. Prior to installation decide if you require left hand or right hand exit of the flow and return pipes from the product and then fix the coil in position using the screws provided.

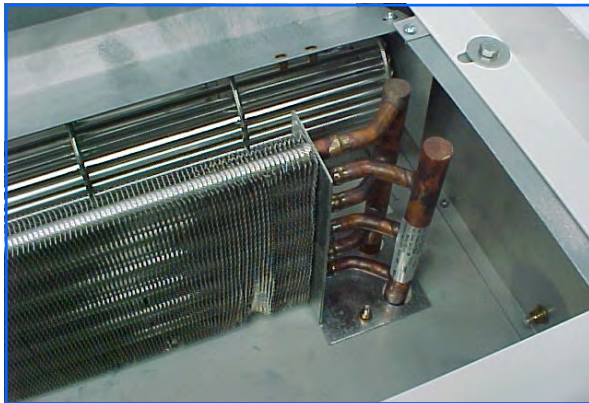

After fitting the coil and side supports fit the air deflector plate to the side supports and rotor cut-off plate using the screws provided.

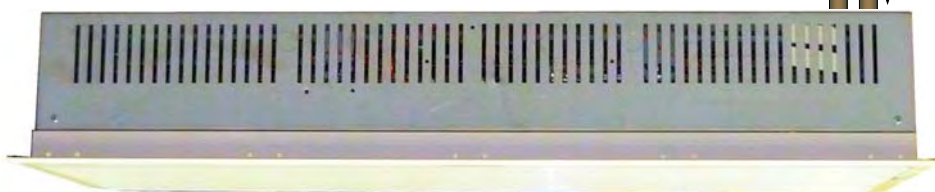
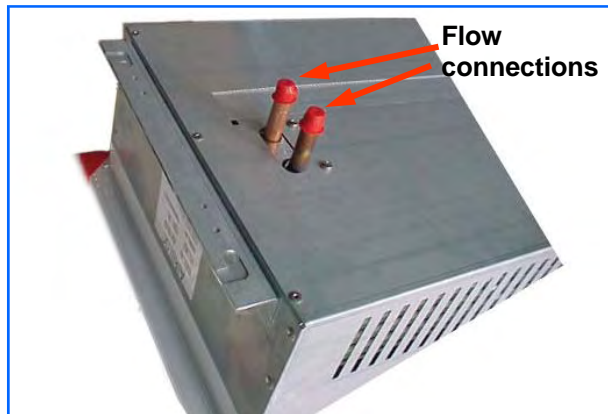

Fig.9 LPHW connections.



The LPHW copper tubing connections are as shown in fig.9 above and are 15mm outside diameter. Ensure correct water seal fittings are used. We recommend the use of a suitable water mains isolation valve to ease any maintenance.

Carefully close the grille and refit the fixing screw.

Test product as shown in the User Instructions.

5.6.1 Three Port Valve

An optional 3 port valve (supplied by others) can be used on the flow and return pipes to divert the hot water from the unit when not in use.

The valve must be fitted in accordance with the manufactures instructions.

When used in conjunction with the standard AC-ACR programmer, the 3 port valve can be wired into the base unit to open the valve when heat is selected (see section 4.5). This valve must operate on 230V.

Note: This option can not operate with a SmartElec unit.

Fig.10 Typical schematic of a 3 port valve system

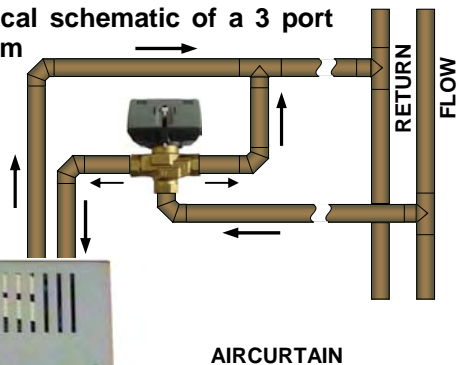

5.7 Installation wiring

With the grille door open, connect the electrical supply and program panel interconnecting wiring/factory supplied cables to the relevant terminals on the controller base unit.

Connect any interconnecting wiring/factory supplied cables to the programme panel.

Connect any optional wiring as required.

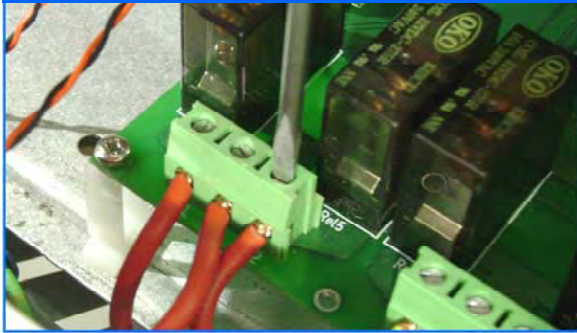

For full details see wiring diagrams in section 4. Ensure the correct diagram is used based on the information from the air curtain data plate and optional manufactures information.

5.8 Installation details - optional Case

The ACR unit can also be mounted within an optional pre-coated outer case for use in doorways with restricted space or areas with no suspended ceiling or bulkhead.

The cases either come in two halves (as shown) for the 1000mm and 1500mm or four individual sides for the 2000mm.

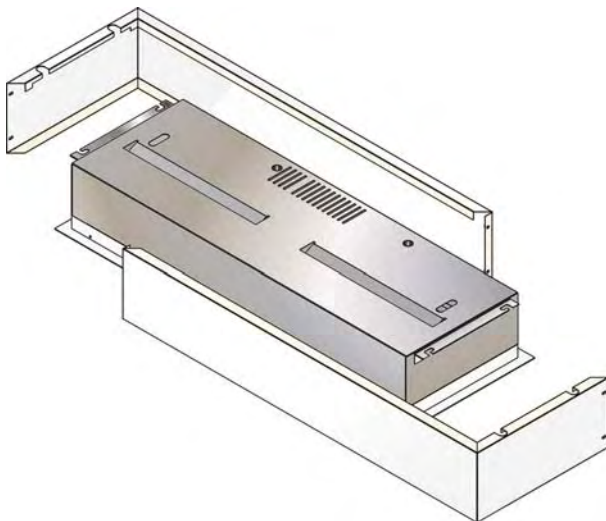

Install the ACR unit using drop rods as previously described.

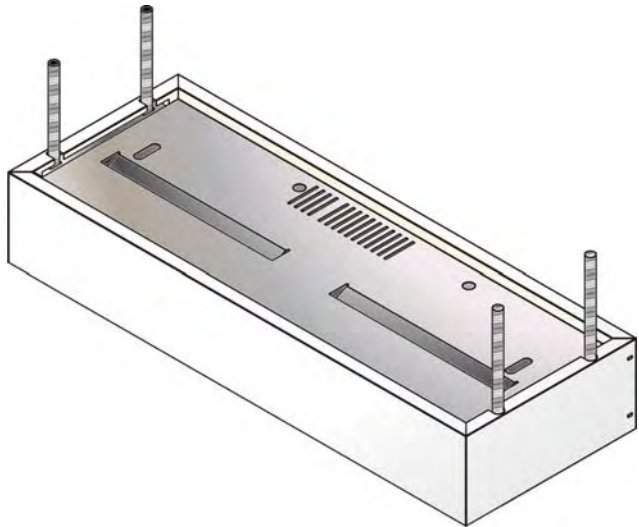

The sides of the case simply 'wrap' around the exposed body of the air curtain fixing at two edges (all four edges in the case of the 2000mm), with screws.

6. Servicing & Maintenance.

! ALWAYS ENSURE THAT THE MAIN EXTERNAL ELECTRICITY SUPPLY IS SWITCHED OFF BEFORE COMMENCING ANY MAINTENANCE ON THIS HEATER.

To obtain the best results from the heater, it is essential to avoid the accumulation of dust and dirt within the unit on the air inlet and discharge grilles. For this reason regular cleaning is necessary, paying particular attention to the removal of dirt build up on the rotor blades.

Cleaning of the fan is best carried out with a soft brush.

A single drop of light oil should be applied to the motor bearing from time to time.

The product should be serviced annually. Servicing shall be undertaken by a competent person. Airbloc offer a service facility, call 01384 489700.

Step 1

Using a 4mm Allen key slacken the captive M6 Allen screws at the side of the grille.

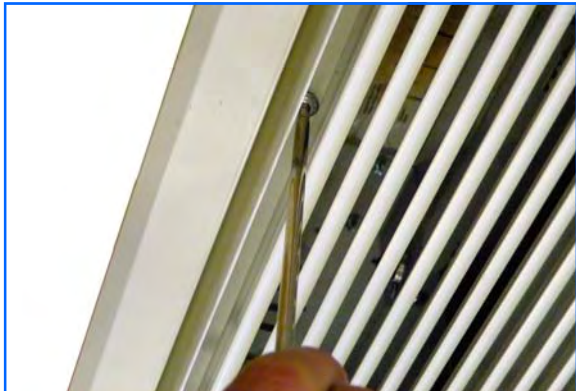

Step 2

Access to the inside of the air curtain grille can be made.



Open the grille. The grille is hinged to prevent the inner frame from dropping

Step 3





With a soft brush clean away any dust from the motor and elements.

Check all connections and components for soundness or signs of deterioration and replace as necessary.

Re-assemble and test.

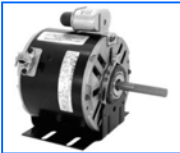

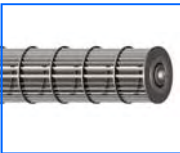
7. Spare parts

7.1 General

Description	ACR100SE6/ ACR100SE9/ ACR100SW9/ ACR100SA	ACR150SE6/ ACR150SE12/ ACR150SW12 /ACR150SA	ACR200SE9/ ACR200SE18/ ACR200SW18 /ACR200SA	ACR120HE12/ ACR120HW12 /ACR120HA	ACR180HE18/ ACR180HW18 /ACR180HA
 Motor	100003	100003	100012	100535	
 Contactor (where reqd)	n/a		900078	n/a	900078
 Rotor Left Hand	100001	100006	100010	100539	100540
 Rotor Right Hand	100002	100007	100011	100536	100537
 Thermal cut out (where reqd)	900001				









7.2 AC-ACR-PANEL controller

⚠ Due to the nature of it's construction, it is not advisable to repair damaged electronic components on either the AC-ACR base unit or AC-ACR-PANEL programmer

 Program Keypad	AC-ACR-PANEL				
 Base unit	AC-ACR-PCB				
 Outside Air Sensor	SC-OS				

7.3 SmartElec2 controller

⚠ Due to the nature of its construction, it is not advisable to repair damaged electronic components on either the SmartElec2 base unit or Program panel.

	Description	All models		Description	All models
	Program Panel	108221		Control Fuse	900473
	Panel P.C.B	SELEC2RP		Outdoor sensor	SC-OS
	Base Unit	SELEC2BU		Data cable c/w plugs	2M SE2-CABLE-2 10M SE2-CABLE-10 20M SE2-CABLE-20 30M SE2-CABLE-30 50M SE2-CABLE-50 100M SE2-CABLE-100
	Heat Sensor	SELEC2HS			
	Fuse	900471			

7.4 Heating mediums

Element assembly

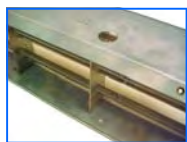

Rating	6kW	9kW	12kW	18kW
SE 1Pha Part No	101565/107817	107818	-	-
Length	1.0m/1.5m	2.0m	-	-
SE 3Pha Part No	-	100004	100008	100013
Length	-	1.0m	1.5m	2.0m
HE Part No	-	-	100526	100527
Length	-	-	1.0m	1.5m

Coil LPHW only



Rating	9kW	12kW	18kW
HE Part No	-	103680	103607
Length	-	1.0m	1.5m
SE Part No	100197	100198	100199
Length	1.0m	1.5m	2.0m

8. Fault Finding.

8.1 General

If the air curtain does not operate after running through the detail provided in Section 6, then a suitably competent service engineer should be called to identify the nature of the fault.

Note The manufacturer operates a service function from the address provided in these instructions.

All Air Curtains are fitted with fuse protection and motor thermal protection.

Other faults in relation to the element, motor and wiring should be identified using conventional fault finding techniques.

In the event that electrical components are replaced, please ensure that electrical safety checks in accordance with the regulations in force in the country of use are undertaken.

8.2 Electrically heated units only.

For the service engineer, please note that there are 2 thermal cut-outs incorporated in the air curtain which need to be manually reset. The cut-outs are located either side of the main PCB.

Re-setting a thermal cut-out may help to identify the nature of the fault however we do not recommend re-set without a thorough investigation into why the cut-out operated.

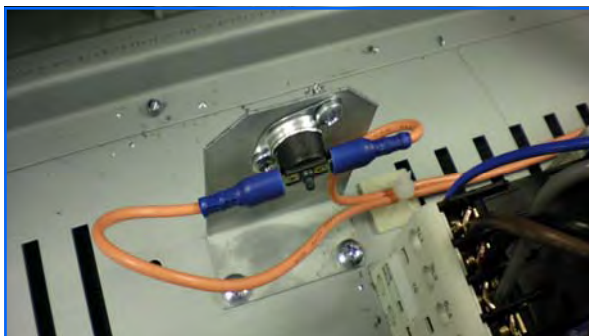

fig.11. Thermal cut-out

8.3 Electronic Controller.

If the air curtain goes into thermal trip (overheat) the AC-ACR-PANEL keypad displays an 'ERR' code. Refer to air curtain instructions to remedy.

The electronic control base unit is protected from any short circuit on the air sensor or heatsink sensor as the short circuit will cause the temperature to go high and trigger over temperature alarm.

8.4 SmartElec2 Controllers.

The SmartElec2 control raises an alarm if any of its inputs are outside their normal working scope. Alarms are displayed on the program panel as a code with a prefix "E". **0 E6** The first number represents the air curtain address. See chart over.

As the alarms are mutually exclusive, the first alarm code displayed on the program panel will stay on until the fault has been cleared.

Apart from the communication failure alarm **0 --** which could be due to a broken connection of the data link and air curtain not found alarm, **E rr** which could be due to incorrect addressing, all other alarms will cause the base unit to switch off the heater output.

The SmartElec2 base unit is protected from any short circuit on the air sensor **0 E1** or heat sink sensor **0 E4** as the error will cause the temperature to rise and trigger over temperature alarm. **0 E1**

There are five basic checks to perform should **0 --** appear on the program panel display. These are as follows:

1: Continuity: Use a multimeter to check continuity between each end of all four cores at the plugs

2: Short circuit: Use a multimeter to check that there are no short circuits between any of the four cores.

N.B. This test should be done with both ends of the cable disconnected to avoid false readings.

3: Plugs: Check that the plugs are firmly seated on the circuit board pins in both the program panel and on the base unit.

4: Addressing: (Network versions only). If two or more air curtains are networked, check that each base unit has a unique address as described in section 12.4

5: Network cables: Ensure that the total run of all cables in the network does not exceed 110m including the cable to the program panel.

If a panel has never before been run, it automatically starts in engineer's mode when first powered-up. To exit this mode, press and hold the  Button.

Alternatively, the engineer's mode automatically self-clears after approximately 10 minutes of non-activity on the switches.

The system can be reset by powering-up the panel whilst holding down the **SELECT** and **—** buttons.

The display shows the 'start' pattern but then goes blank.

Release the buttons where upon the display resumes and the system addressing commences, finding only those air curtains which are actually connected and working.

If **E n9** appears on the display, press and hold the **+** button for a few seconds then release. The display will then return to the normal mode.

8.4.1 SmartElec2 fault codes

*NOTE: '#' denotes the controller number.

Code	Description	Symptom	Possible cause	Remedy
#*__	COMMUNICATION FAILURE.	No control on faulty unit	Bad data cable connection Damaged cable	Check data cable(s) and plugs Repair/replace damaged cable
# E1	AIR SENSOR TEMPERATURE TOO HIGH or AIR SENSOR FAILURE.	Fan operating, no heat	High ambient air temperature	Check ventilation
			Impeller turning in wrong direction	Check rotation of impeller
		Fan operating, no heat	Motor failure	Check motor & replace if necessary
			Air sensor cable disconnected Air sensor broken	Check cable Replace air sensor
# E3	HEATSINK TOO HOT	Fan operating, no heat	High ambient air/faulty base unit	Replace SmartElec base unit
# E4	HEATSINK SENSOR FAILURE	Fan operating, no heat	Heatsink sensor wiring disconnected/faulty	Check wiring
			Heatsink sensor faulty	Replace SmartElec base unit
# E5	EXTERNAL TEMPERATURE SENSOR FAILURE	Unit runs, but no external temperature control	External temperature sensor faulty	Replace sensor
			External temperature sensor wiring faulty	Repair/replace faulty wiring
# E6	OVERHEAT THERMOSTAT OPEN CIRCUIT	Fan operating, no heat	Overheat thermostat open circuit	Reset/replace overheat thermostat

8.4.2 SmartElec base unit LED indicator location/function:

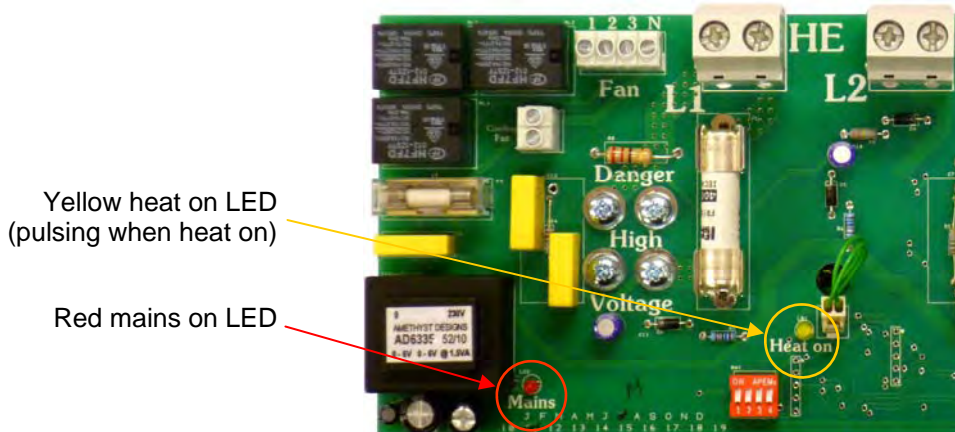

9. Parts replacement.

9.1.1 Electrical element replacement SE.

Step 1

Using a 4mm Allen key slacken the M6 Allen screws at the side of the grille. Access to the inside of the air curtain grille can be made. Open the grille. The grille is hinged to prevent the inner frame from dropping.

Step 2

Disconnect element wires and if necessary remove cut-off plate fixing screws.



Step 3

Remove element top fixing screws. Locate and remove element fixing screws by inserting a screwdriver through the hole indicated below.



Step 4

Lift out element cartridge, replace as required.



9.1.2 Electrical element replacement HE.

Step 1

Using a 4mm Allen key slacken screws securing the grille. Remove 4 screws securing the top of the case and remove. Slacken two hinging bolts on both ends. Remove three bolts securing the access plate. Carefully hinge down the access plate. *Note: Take the weight as access plate swings down.*

Step 2

Carefully remove connections to the elements, noting wiring configuration.

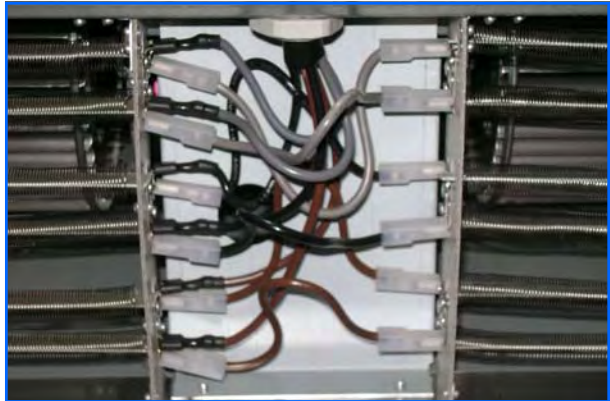

Step 3

Remove two bolts securing elements.

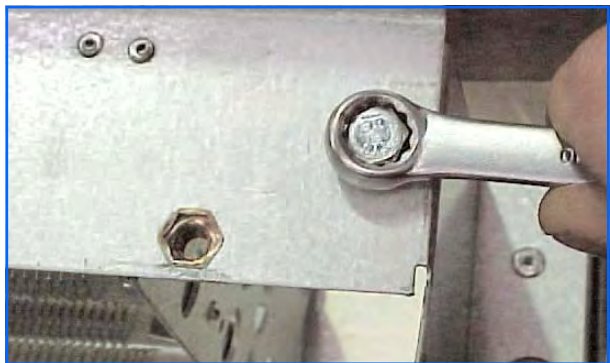

Step 4

Lift out element cartridge, replace as required.



9.2.1 Rotor and motor replacement SE

Step 1

Using a 4mm Allen key slacken the M6 Allen screws at the side of the grille. Access to the inside of the air curtain grille can be made. Open the grille. The grille is hinged to prevent the inner frame from dropping.

Step 2

Remove fastenings securing the motor end of the deflector plate, including the single side screw (arrowed).

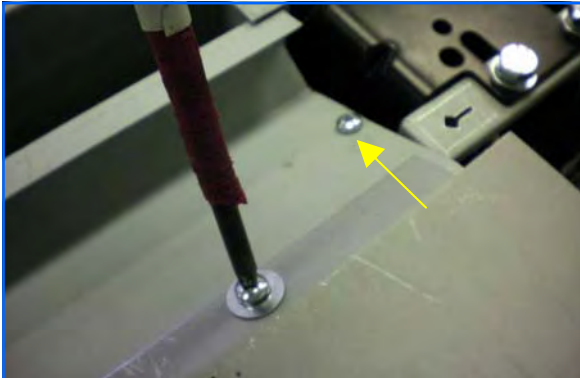

Step 3

Remove the four screws securing the rotor support bracket and the opposite end of the deflector plate. Remove plate.

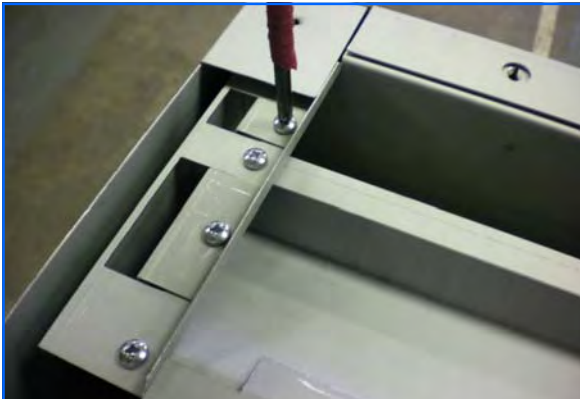

Step 4

Using a 2.5mm Allen key, slacken the rotor hub grub screw.



Note: when refitting ensure that the grub screw bears on the flat of the motor shaft.

Step 5

Push the rotor support bracket away from the rotor to release the rotor bearing.

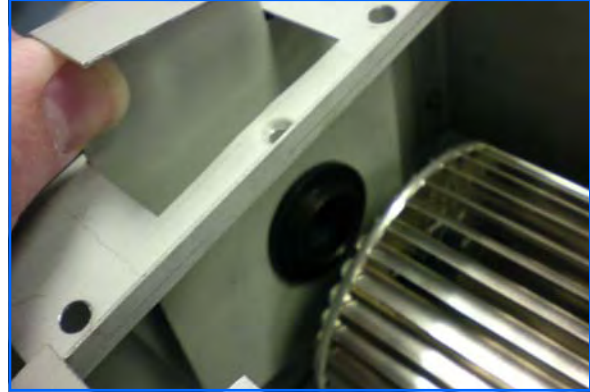

Step 6

Lift the rotor clear of the motor shaft then remove it from the air curtain.

Step 7

Disconnect fan motor cables including the earth which is bolted to the chassis. (See below).

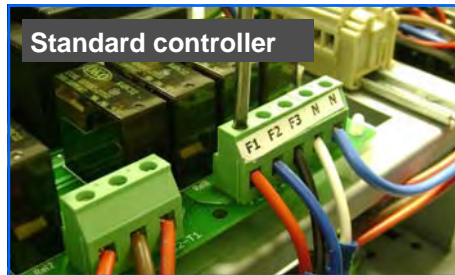

Step 8

Remove the four 10mm bolts securing the motor to its bracket.



Step 9
Swing the movable bracket clear and remove the motor.

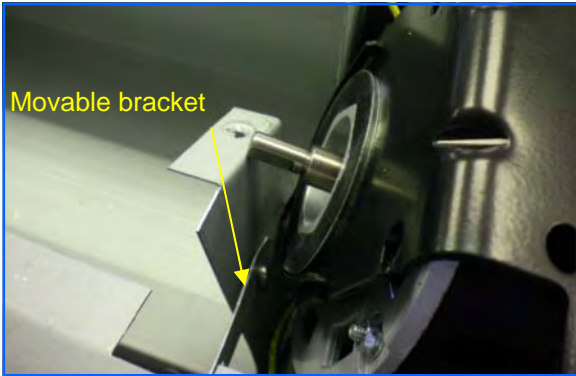

Step 4
Turn retaining latch to release chassis.



9.2.2 Rotor and motor replacement HE

Step 1
Using a pozidrive screwdriver undo screws securing the grille and remove. Remove 4 screws securing the top of the case and remove. Slacken two hinging bolts on both ends. Remove three bolts securing the access plate. Carefully hinge down the access plate. *Note Take the weight as access plate swings down.*

Step 2
Remove 6 screws securing access panel and carefully remove panel.



Step 3
Remove 8 bolts securing wheel assembly.

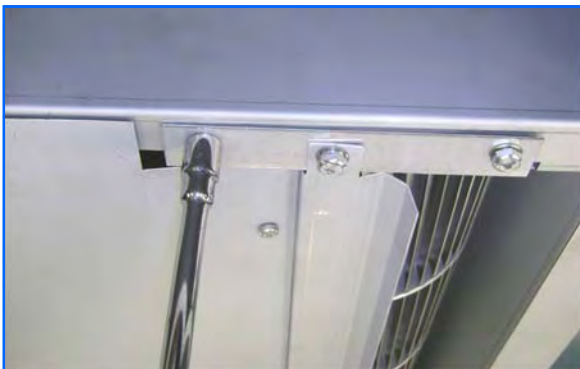

Step 5
Holding handle, carefully pull motor and air wheel assembly forward.



Step 6
Remove screw securing rotor bearing plate. Repeat for opposite side.



Step 7
Slacken grub screw securing rotors to the motor shaft, remove rotor. Repeat for opposite rotor.

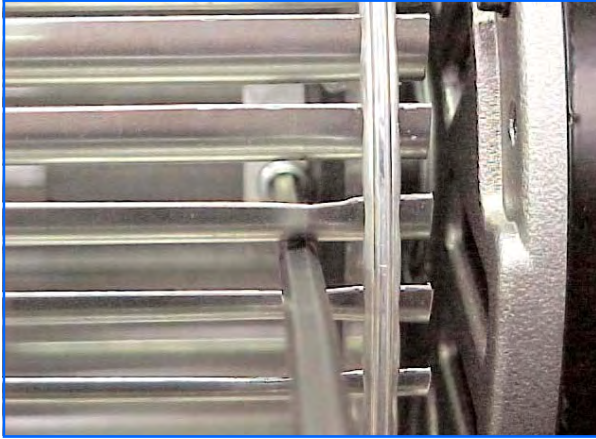

Step 8

Disconnect the wires from the motor to the controller base unit.

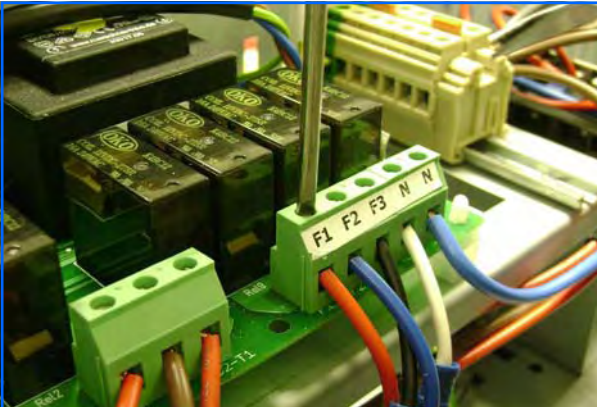

Step 9

Remove the bolts securing the motor to the chassis.

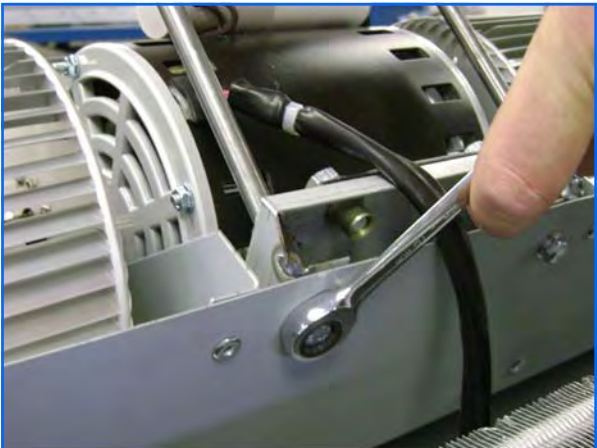

Remove motor from air curtain.

Replace motor in reverse order. Carefully close the grille and refit the fixing screw.

Test product as shown in the User Instructions.

9.3 LPHW coil replacement.

Step 1

Using a 4mm Allen key slacken screws securing the grille. Remove 4 screws securing the top of the case and remove. Slacken two hinging bolts on both ends. Remove three bolts securing the access plate. Carefully hinge down the access plate. *Note: Take the weight as access plate swings down.*

Step 2

Disconnect flow connections with appropriate tools.



Step 3

Remove the air deflector plate and the side support plates, retaining the screws.

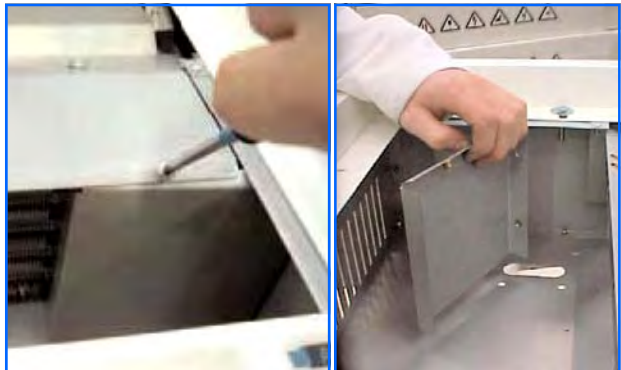

Step 4

Remove coil fixing screws from the outside of the air curtain body.

Step 5

Withdraw the coil.

Replace LPHW coil in reverse order.

10. User Instructions.

fig.12. AC-ACR-PANEL Programmer



10.1.1 Keypad Buttons

The  button will allow you to navigate.

The  button will allow you to increase the setting.

The  button will allow you to decrease the setting.



10.1.2 Operation

On first power up, the display panel will have the following default settings:

- F. 0 (no fan)
- H. 0 (no heat)
- 1. 16 (°C. Heat set point - Auto mode only)
- 2. 7 (°C. half heat set point - Auto mode only)
- D. 2 (fan speed in door switch mode)

Note: Subsequent power ups will retain any entered settings in the display panel internal memory.

Press the  or  buttons to toggle between the 'F' (Fan), 'H' (Heat) and On/Off Parameters.

Prefix 'F' denotes the **FAN SPEED**. This can be either 1: slow ; 2: medium or 3: fast speed. 0 setting denotes the unit is **OFF**.

To alter the current speed, press the  button. The value will start flashing.

Press the  or  buttons to increase/decrease the desired setting.

Press the  button to confirm new setting. A delay of 7 seconds will return to the original display.

Prefix 'H' denotes the **HEAT** setting. This can be either 1: low heat; or 2: high heat. 0 setting denotes the unit is set at fan only.

To alter the current setting, press the  button. The value will start flashing.

Press the  or  buttons to increase/decrease the desired setting.

Press the  button to confirm new setting. A delay of 7 seconds will return to the original display.



The next parameter will either turn the unit On or Off.

To turn the unit Off, press the  button. 'On' will start flashing.

Press the  button. 'Off' will start flashing.

Press the  button to confirm new setting.

To turn the unit On, press the  button. 'Off' will start flashing.

Press the  button to alter to 'On'.

Press the  button to confirm new setting. A delay of 7 seconds will return to the 'F' Fan parameter.





10.1.3 Engineers settings



10.1.3.1 Auto Mode

The controller can be set to automatic control only when used in conjunction with an optional outside sensor.

To access the engineers setting, first ensure that the display is in the (H) HEAT parameter. Press and hold the  button for 5 seconds. Set point '1' will appear.



If the outside air temperature is above this value, there is no heat power. If the outside temperature falls below this value but is above set point 2, then the heat will be at half power. (Range: 0 - 30 degrees).

To alter the setting, press the  button then the  or  buttons to increase/decrease the desired setting.

Press the  button to confirm new value and use the  button to move to the next setting. (A delay of 7 seconds will return to the original display.)

If you have previously pressed the  button, Set point '2' will appear.

If the outside air temperature falls below this value, the heat will be at full power. If the outside temperature is above this value but is below set point 1, then the heat will be at half power. (Range: 0 - 30 degrees)



To alter the setting, press the  button then the  or  buttons to increase/decrease the desired setting.

Press the  button to confirm new value.



Press the  button, setting "A.Of" will appear.

This setting will enable the Auto Mode. (Range: On/Off)

To alter the setting, press the  button then the  or  buttons to toggle between the "A.Of" and "A.On" modes. "A.On" enables the air curtain to run under automatic control from the optional outdoor sensor. "A.Of" enables the air curtain to run under normal control.

To return to the engineering setting mode press and hold the  button for 5 seconds.

To return to normal operating mode press and hold the  button for 5 seconds.







10.1.3.2 Door Switch Mode

The controller can be set to a preset fan speed when the door opens. This function can only when used in conjunction with a door switch.

To access the engineers setting, first ensure that the display is in the (F) FAN parameter. Press and hold the  button for 5 seconds. Setting 'd' will appear.

*The air curtain operates as normal under the program of the Fan and Heat settings. As the door opens the air curtain changes state to the settings preset in this mode. As the door closes, the air curtain returns to normal. (Range: 1: slow ; 2: medium or 3: fast speed. 0 setting denotes the unit is **OFF**.)*

To alter the setting, press the  button then the  or  buttons to increase/decrease the desired setting.

Press the  button to confirm new setting. A delay of 2 seconds will return to the original display.



Note: All air curtains connected within the network system will operate in unison under the user settings of the single keypad.

Any air curtain can respond to optional circuits i.e. External switch (BMS); or Door switch or Internal/external sensors, ON AN INDIVIDUAL BASES.

10.2 Option SmartElec2 Controller



fig.13. SmartElec2 Programmer

10.2.1 Keypad buttons



The buttons have the following functions:



Press the select button to allow navigation.



Press the + button to increase a setting.



Press the - button to decrease a setting.

10.2.2 Keypad display

10.2.2.1 Normal mode displays

Display	Meaning
- -	First power up
E rr	No air curtains found
0 25	Curtain address and temperature set point

10.2.2.2 Normal Operation

During normal operation mode the display is dimmed.

Pressing the  button, will put the panel into active mode. If no button is pressed for several seconds the display reverts to normal mode.

During normal operation the unit will display for example:

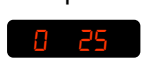
 where '0' is the curtain address, and '25' the temperature measured for the unit.

Where multiple air curtains exist in a network, the display scrolls through each unit in turn, changing approximately once every second.

If the air curtain is in operation and under heat demand, a 'decimal point' is shown after the air curtain address.





10.2.3 OFF mode.

During normal operation, press and hold the  button for approximately two seconds. The display blanks until you release the button. The heating and fans are now turned off. Releasing the button in less than this time and the action has no effect.



Where multiple air curtains exist in a network, this action turns off all air curtains.

10.2.4 Settings Mode

10.2.4.1 Activate settings display

To enter the Settings mode press the  button. This will illuminate the screen. Press the  button till the desired setting is shown.

By pressing the  button it will also advance to the next setting.

Note: If a setting has been altered by using the  or  buttons, it must be confirmed by pressing the  button.

10.2.4.2 Settings displays

Press the  button to advance through the settings.

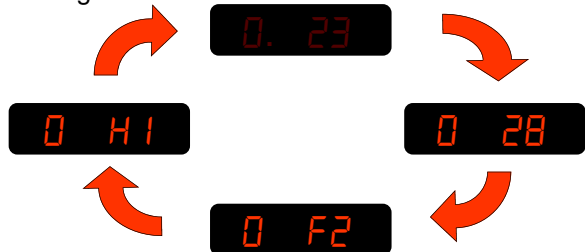

Where multiple air curtains exist in a network and controlled from a single keypad, these will be detected and displayed in turn, for example:

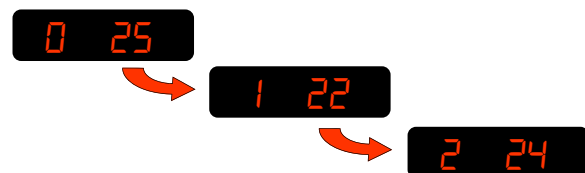



Any air curtain in the network can be accessed by pressing the  button when it's address appears on the display. The settings can then be accessed as previously described.

10.2.5 Set-up configurations

10.2.5.1 Set fan speed

Once the display becomes illuminated press the  button once. Display shows the fan speed.

Press  to increase fan speed.

Press  to decrease fan speed.

Three speeds and an 'off' setting are available:

 Speed 1  Speed 2

 Speed 3  Fan 'off'

10.2.5.2 Set heat

Press the  button again Display shows the heat setting.

Press  to set heat 'on'.

Press  to set heat 'off'.

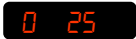
If no button pressed for 2 seconds, display will revert to normal user. eg 

10.2.5.3 Set temperature

Press the  button once to allow changes to be made.

Press  to increase temperature set point. (max 35°C)

Press  to decrease temperature set point. (min 16°C)

Display shows for example: 

10.2.5.4 Networked air curtains

Where multiple air curtains exist in a network and controlled from a single keypad, these will be detected and displayed in turn, for example:





Any air curtain in the network can be accessed by pressing  when it's address appears on the display. The settings can then be changed as previously described.

10.2.6 Engineers settings



Other options are available in engineer's mode.

To access the engineers mode *either*:



press and hold the  button for a few seconds until the display goes blank, then press 

briefly. The display will show 

or

Power-up the system with the  and  buttons pressed and release when the display goes blank the display will show



As in normal mode, Engineers set-up mode is started by pressing the  button whereupon the display will illuminate. Advance through the normal modes settings of temperature, fan and heat by pressing the  button.





Pressing the  button again advances to further options to allow other settings of the system. The engineers set-up options listed herewith depend various factors e.g. optional door switch, multiple air curtains etc.

Notes: If a panel has never before been run, it automatically starts in engineer's mode when first powered-up.

Engineer's mode automatically self-clears after approximately 10 minutes of non-activity on the switches.

10.2.6.1: Door link settings:

This provides an alternative fan speed and heat setting which is activated only when the door link is open circuit.

The fan speed is accessed by pressing the  button until the display shows:  Use the  and  buttons to change the setting.

Display

Meaning



Fan off







Fan speed 1











Fan speed 2





Fan speed 3





The temperature setting when the door link is open circuit is accessed by pressing the  button until the display shows . Use the  and  buttons to alter the temperature value.

Display	Meaning
	Heat off
	5°C
	10°C
	15°C
	20°C
	25°C
	30°C
	35°C

10.2.6.2 Link-group interlock

If there is more than one air curtain, a group interlock option may be set. This provides an alternative fan speed and heat setting when activated by certain external connections on individual air curtains.



This function is accessed by pressing the  button until the display shows  (where '0' is the air curtain address to be used as a master unit for interlocks.)

Display	Meaning
	Default setting
 to 	Master setting range
	Other air curtains

See table below for possible settings.

Master setting	Function
1	Timer/BMS interlock
2	Door interlock
3	Timer/BMS/door interlock
4	Stat interlock
5	Timer/BMS/stat interlock
6	Stat/door interlock
7	Timer/BMS/stat/door interlock



10.2.6.3 All air curtains



This function is accessed by pressing the  button until the display shows .

Using this setting all air curtains in a network respond to the same settings. Settings for individual air curtains can still be changed if required.

10.2.6.4 External temperature

This is only displayed if the factory supplied optional external temperature sensor is connected to the air curtain.

This function is accessed by pressing the  button until the display shows .

Use the  and  buttons to change to the desired temperature setting.

If the external temperature is equal to the set temperature, all air curtains are turned off. The temperature must then drop to 3°C below the set temperature before the air curtains are turned back on.

Note: for multiple air curtains - more than one can have an external sensor connected. When this is the case the sensor values are displayed as an average. (If one external sensor goes faulty, the average is worked out from the remaining working ones).

10.2.6.5 External temperature offset

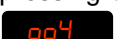
This function is accessed by pressing the  button until the display shows .



This setting allows the temperature setpoint to be automatically increased as the external temperature falls to, or below, zero. For instance, a setting of 4 means a +4°C offset at 0°C. The maximum offset is 9°C. If this feature is not required the setting should be .

Note: When more than one air curtain is used, this feature will only work under the 'all controllers' setting.

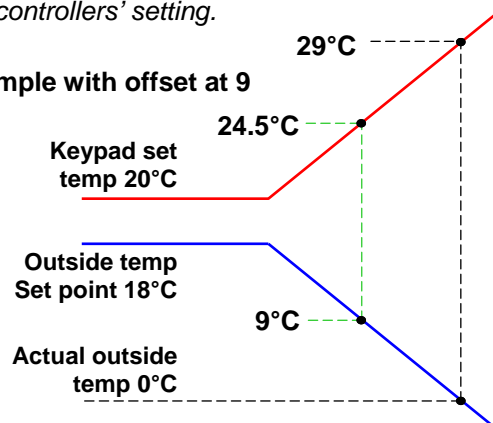
Example with offset at 9

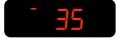

10.2.6.6 Temperature limits



This function is accessed by pressing the  button until the display shows  and  respectively i.e. maximum and minimum set limits for set temperature.

Use the  and  buttons to change to the desired limit temperature settings.

The maximum (default 35°C) may be set anywhere between the current minimum and 50°C, and the minimum, (default 16°C) may be set anywhere between 3°C and the current maximum.



To exit the engineers mode press and hold the  button for a few seconds.

10.2.7 Power-up Manual Reset

The system can be reset by powering-up the panel whilst holding down the  and  buttons.

The display shows the 'start' pattern but then goes blank.

Release the buttons where upon the display resumes and the system addressing commences, finding only those air curtains which are actually connected and working.

If  appears on the display, press and hold the  button for a few seconds then release. The display will then return to the normal mode.

10.2.8 Air curtain addressing

All air curtains work on an address address to communicate with the keypad and are supplied with an default address of '0'.

Where multiple air curtains exist in a network they must be re-addressed using a unique address (0-9/A-F). This is achieved using a 4 way bitswitch mounted on the base unit PCB (see photo opposite)

The keypad will check all addresses on first power up and this is displayed as the first digit on the display (in a network set up, all addressees will be viewed in rotation).

Note: If any address is altered after initial power up or an air curtain removed after initial installation, the keypad will also retain the original address although unable to respond.

To remove this unwanted address(s) follow the details in 10.2.7 Power-up Manual Reset.

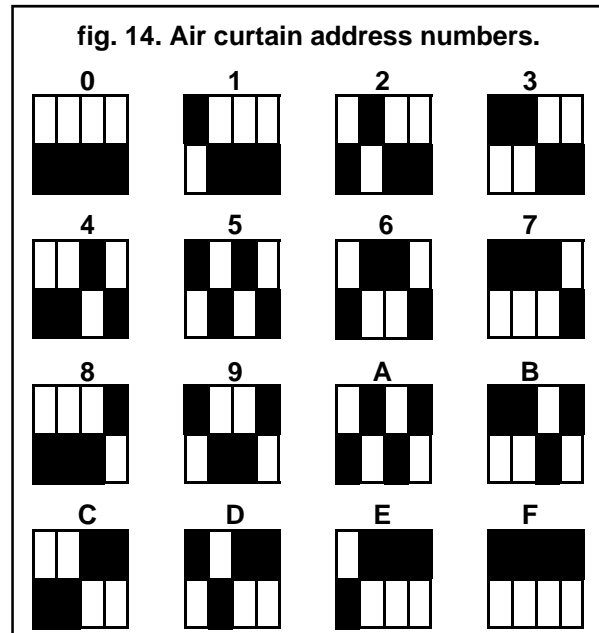
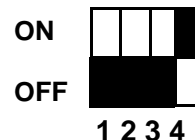

fig. 15. Bitswitch position



The black shaded areas represent the switch position.

The example shows the **ON** air curtain set to No.8.



10.2.9 Keypad sequences

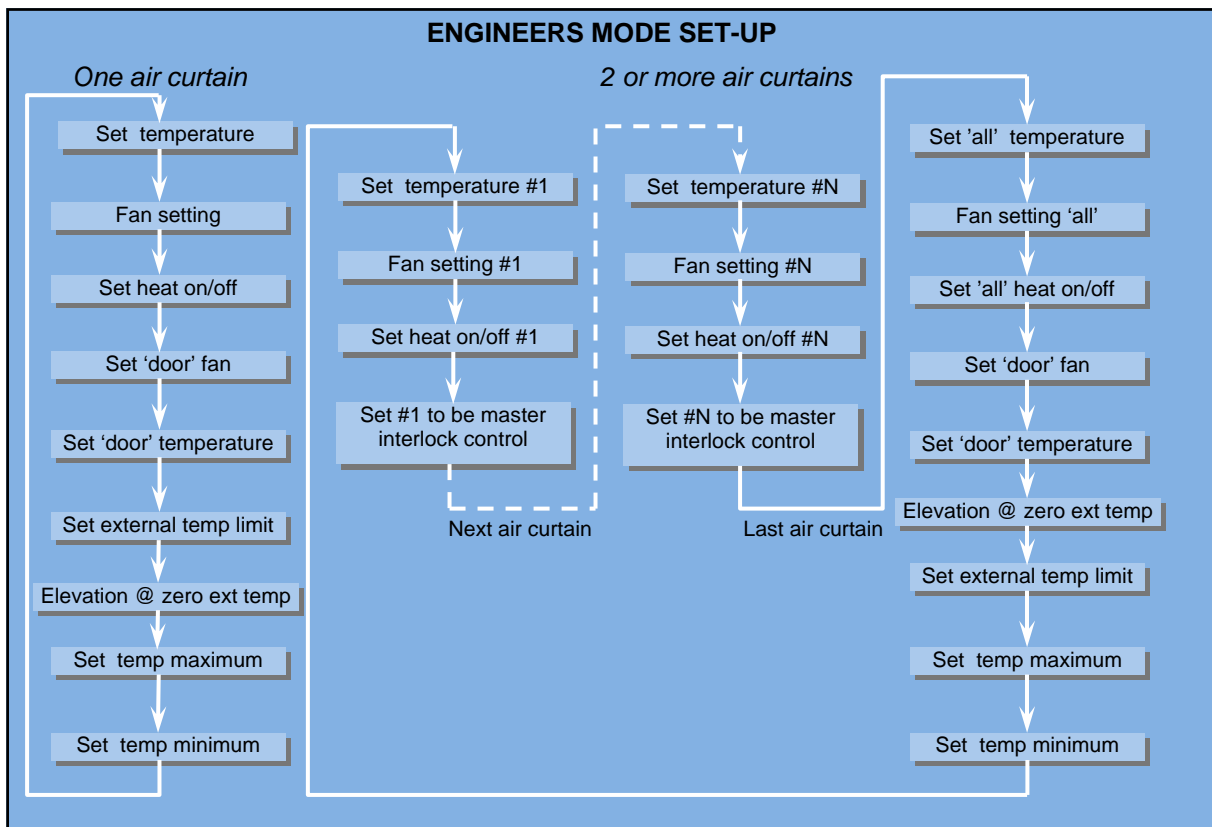
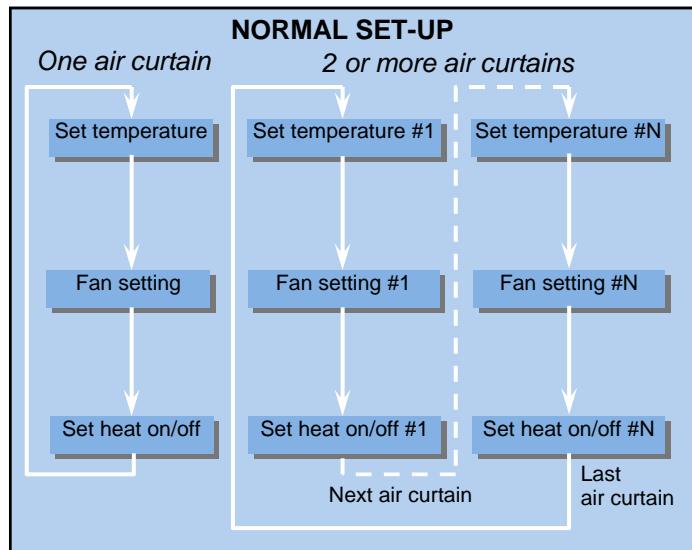
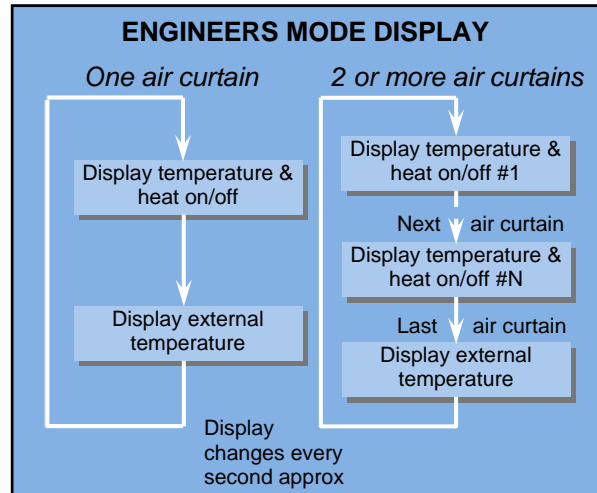
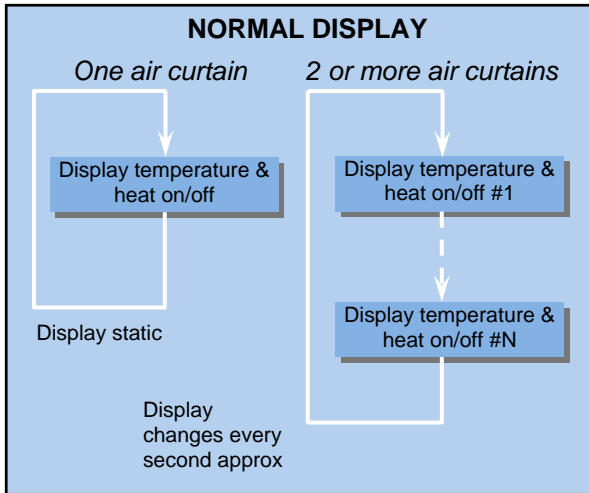

AmbiRad Group

Heating and Ventilation Solutions

AMBIRAD **AIRBLOC** **NORDAIRNICHE** **BENSON**

A Thomas & Betts Company. Registered in England No. 1390934. Registered office: 27/28 East Castle Street, London.

AmbiRad UK is a registered trademark of AmbiRad Limited. Because of continuous product innovation, AmbiRad reserves the right to change product specification without due notice.

AMBIRAD LIMITED
Fens Pool Avenue
Brierley Hill
West Midlands DY5 1QA
United Kingdom

Tel: **01384 489 700**
Fax: **01384 489 707**

ambiradsales@tnb.com
www.ambiradgroup.co.uk