

## INSTALLATION AND OPERATING MANUAL

# AC/CMS Commercial & Retail

Electrically Heated, Ambient & LPHW

---

### WARNINGS

Nortek Global HVAC (UK) Limited equipment must be installed and maintained in accordance with the requirements of the Codes of Practice or rules in force. All external wiring MUST comply with the codes of practice or rules in force in the country of installation.

Improper installation, adjustment, alteration, service or maintenance can cause property damage, injury or death. Read instructions before installing or servicing this equipment. Gas-fired appliances are not designed for use in hazardous atmospheres containing flammable vapours or combustible dust, containing chlorinated or halogenated hydrocarbons, or in applications with airborne silicone substances.

**Reznor® is a registered trademark of Nortek Global HVAC, LLC.**

## Introduction.

**W**elcome to the range of Airbloc AC Commercial and Retail Air Curtains. Local regulations may vary in the country of use and it is the installers responsibility to ensure that such regulations are satisfied

All installation and assembly procedures must be carried out by suitable competent persons. Commissioning and service procedures must be carried out by suitable qualified persons to the statutory regulations in the country of use.

When installing, commissioning and servicing is undertaken on these heaters due care and attention is required to ensure that working at height regulations are adhered to at the mounting heights specified.

All Dimensions shown are in mm unless



**PLEASE READ** this document prior to installation and use. The safety of this heater is guaranteed only by the correct usage in accordance with these instructions, therefore it is recommended that they are retained for future reference.

*The manufacturer reserves the right to alter specifications without prior notice.*

Any reference made to Laws, Standards, Directives, Codes of Practice or other recommendations governing the application and installation of heating appliances and which may be referred to in Brochures, Specifications, Quotations, and Installation, Operation and Maintenance manuals is done so for information and guidance purposes only and should only be considered valid at the time of the publication. Benson Heating cannot be held responsible from any matters arising from the revision to or introduction of new Laws, Standards, Directives, Codes of Practice or other recommendations.

### **IMPORTANT NOTICE TO INSTALLERS**

**Installers should satisfy themselves that the gas pipework installation is carried out in accordance with all current legislation, Codes of Practice and recommendations .**

**Additionally it may be necessary to protect the gas valves which form part of the heater or burner assembly from potential pipe contamination particularly, but not exclusively, where copper gas pipework is used.**

**In instances where copper pipework is to be used for all or part of a gas pipework installation, including short length final connections then we advise that installers consult with gas supplier or provider and satisfy themselves what additional precautions may be necessary**

# Document Index.

1	Installation Requirements		6.3 Commissioning/Testing
	1.1 Compliance Notice		6.4 Specification
	1.2 Certificate of Conformity		6.4.1 Non-maintained
	1.3 General Product Information		6.4.2 Maintained
	1.4 Model Definition		6.5 Installation
	1.5 General Requirements	7	6.6 Wiring Diagram
	1.6 Health and Safety		
	1.7 Delivery and pre-installation checks	8	Servicing & Maintenance Instructions
	1.8 Location		
	1.9 Clearance Distance		Spare Parts
	1.10 Electrical Supply		8.1 General
	1.10.1 Electronic Controller		8.2 Standard Controller
	1.10.2 SmartElec3 Controller		8.3 SmartElec3 Controller
			8.4 Heating mediums
2	Dimensions	9	Fault Finding Guide
	2.1 AC Air Curtain		9.1 General
	2.2 CMS Chassis Air Curtain		9.2 Electrical Heated
	2.3 Program keypad dimensions		9.3 Standard Controller
			9.4 Optional SmartElec3Controller
			9.4.1 Fault Code chart
			9.4.2 LED indication
3	Technical Specifications	10	Replacing Parts
	3.1 Electrical Heated, Std Capacity 6&9kW 1P		10.1 Rotor and Motor
	3.2 Electrical Heated, Std Capacity 9-18kW		10.2 Electrical Element
	3.3 Electrical Heated, High Capacity 12-24kW		10.3 LPHW Coil
	3.4 Ambient, Std Capacity		
	3.5 Ambient, High Capacity		
	3.6 LPHW, Std Capacity	11	User and Operating Instructions
	3.7 LPHW, High Capacity		11.1 Standard Keypad
	3.8 Standard Controller		11.1.1 Keypad Buttons
	3.9 SmartElec3 Controller		11.1.2 Operation
	3.10 LPHW/Ambient controls		11.1.3 Standard Settings
			11.1.4 Engineers Settings
			11.1.4.1 Door Link Settings
			11.1.4.2 Link-Group Interlock
			11.1.4.3 All Controllers
4	Wiring Diagrams		11.2 LPHW/Ambient
	4.1 Installer Wiring Electrically Heated 6&9kW 1P		11.2.1 Keypad Buttons
	4.2 Installer Wiring Electrically Heated 9,12,18kW		11.2.2 Operation
	4.3 Installer Wiring Electrically Heated 24kW		11.2.3 Standard Settings
	4.4 Installer Wiring Ambient		11.2.4 Engineers Settings
	4.5 Installer Wiring LPHW		11.2.4.1 Door Link Settings
	4.6 Factory Wiring Electrically Heated 6/9kW 1P		11.2.4.2 Link-Group Interlock
	4.7 Factory Wiring Electrically Heated (up to 18kW 3P		11.2.4.3 All Controllers
only)	4.8 Factory Wiring Electrically Heated 24kW 3P only		11.2.4.4 External Temperature
	4.9 Factory Wiring Ambient		11.2.4.5 External Temperature Offset
	4.10 Factory Wiring LPHW		11.2.4.6 Temperature Limits
	4.11 Network Wiring Ambient/LPHW		11.2.4.7 External & Pipe Cold Sensors
	4.12 Network Wiring Standard Controller		
	4.13 Installer Wiring SmartElec3 Controller		11.3 Optional SmartElec3 Controller
	4.14 Factory Wiring SmartElec3 Controller		11.3.1 Keypad Buttons
	4.15 Network Wiring SmartElec3 Controller		11.3.2 Operation
			11.3.2.1 Normal Mode Display
			11.3.2.2 Normal Operation
5	Installation Requirements		11.3.3 Off Mode
	5.1 Mounting		11.3.4 Settings Mode
	5.2 Electrical Supply		11.3.4.1 Activate Settings Display
	5.3 Installation		11.3.4.2 Settings Display
	5.4 Program Keypad		11.3.5 Set Up Configuration
	5.5 Option SmartElec3 Controller		11.3.5.1 Set Fan Speed
	5.6 LPHW only		11.3.5.2 Set Heat
	5.6.1 3 Port Valve		11.3.5.3 Set Temperature
	5.7 Installation Wiring		
6	Optional Fire Exit Luminaries		
	6.1 General		
	6.2 Remote Switching		

## Document Index cont.

- 11.3.5.4 Networked Air Curtains
  - 11.3.6 Engineers Settings
    - 11.3.6.1 Door Link Settings
    - 11.3.6.2 Link-group Interlock
    - 11.3.6.3 All Air Curtains
    - 11.3.6.4 External Temperature
    - 11.3.6.5 External Temperature Offset
    - 11.3.6.6 Temperature Limits
  - 11.3.7 Power-up Manual Reset
  - 11.3.8 Air Curtain Addressing
  - 11.3.9 Keypad Sequences (std controller)
  - 11.3.10 Keypad Sequences (SmartElec)

# 1. Installation Requirements.

 Isolate any electrical supply to the heater and controller before proceeding.

## 1.1 Compliance notices

The Airbloc AC Commercial and Retail Air Curtain detailed herewith are manufactured by Nortek Global HVAC (UK) Ltd. within a strictly controlled quality environment within the parameters of ISO 9001.

These instructions are only valid if the following country code is on the appliance GB. IE. If this code is not present on the appliance, it is necessary to refer to the technical instructions which will provide the necessary information concerning the modification of then appliance to the conditions of use for the country.

The Airbloc range has been tested and assessed for compliance with the following European Directives.

Machinery Directive:	(2006/42/EC)
Low Voltage Directive:	(2006/95/EC)
Electromagnetic Compatibility Directive:	(2014/30/EU)
Product Liability Directive:	(85/374/EEC)

The manufacturer has taken reasonable and practical steps to ensure that Airbloc AC Air Curtains are safe and without risk when properly used. These air curtains should only be used in the manner and purpose for which they were intended, and in accordance with the recommendations detailed herewith.

The AC Air Curtains have been designed, manufactured, assembled, inspected, and tested, with safety and quality in mind, there are certain basic precautions which the installer and user should be aware of, and they are strongly advised to read the appropriate sections of the information pack accompanying the heater, prior to installation or use.

Nortek Global HVAC (UK) Ltd. supports all new products being supplied to their customers with a comprehensive information pack; this clearly defines mandatory instructions for the safe installation, use, and maintenance, of the appliance(s).

Where proprietary items are incorporated into Airbloc products, detailed information and instructions are also provided as part of the information pack.

It is the responsibility of the installer, owner, user, or hirer, of such products supplied by Nortek Global HVAC (UK) Ltd., to ensure that they are familiar with the appropriate information/manuals, supplied by the manufacturer, and that they are suitably aware of the purpose of the manuals and the safety instructions. In addition, operators must be suitably trained in

the use of the appliance so as to ensure its continued safe and efficient use.

Nortek Global HVAC (UK) Ltd. have a commitment to continuous improvement and therefore reserves the right to amend or change the specification of the Airbloc AC Commercial and Retail Air Curtain range subject to compliance with the appropriate European, national, and local regulations.

Contained within the text of the manual, the words 'Caution' and 'Warning' are used to highlight certain points.



**Caution is used when failure to follow or implement the instruction(s) can lead to premature failure or damage to the heater or its component parts.**



**Warning is used when failure to heed or implement the instruction(s) can lead to not only component damage, but also to a hazardous situation being created where there is a risk of personal injury.**

The Airbloc AC Commercial and Retail Air Curtain range conform to the following harmonised standards:

BS EN ISO 12100:2010

Safety of machinery. General principles for design. Risk assessment and risk reduction

Safety of Machinery - Basic Concepts, General Principles for Design Technical Principles and Specifications

BS EN 60204-1:2006+A1:2009

Safety of machinery. Electrical equipment of machines. General requirements

BS EN 55014-1:2017

Electromagnetic compatibility. Requirements for household appliances, electric tools and similar apparatus. Emission

BS EN 60335-2-102:2006+A2:2016

Household and similar electrical appliances. Safety. Particular requirements for gas, oil and solid-fuel burning appliances having electrical connections

BS EN 60335-2-30:2009+A11:2012

Household and similar electrical appliances. Safety. Particular requirements for room heaters

and to the following European CE directives-

2006/95/EC - low voltage;

2014/30/EU - electromagnetic compatibility.

## 1.2 Certificates of conformity

Certificates are available from the Quality Control Department at Nortek Global HVAC (UK) Ltd.

## 1.3 General product information

Models range from 1000mm to 2000mm in length, in both Standard and High capacity and are available in either Electrically Heated, Ambient or LPHW. They are designed for mounting above or slung on drop rods above doorways.

Each air curtain is supplied with a fully electronic controller giving multi fan and heat settings (electrically operated units) via a simple key pad which can be mounted up to 100m from the air curtain.

Optional BMS time control, external, thermostats and door interlocks can be installed.



The programmer shown above allows the user to control either a single air curtain, or a network of up to 16 air curtains with the same settings, and provides the following functions:-

- Heat On Off or Auto via optional thermostat
- Off or Low, Medium and High Fan Speeds

For further details please refer to section 10.1

Alternatively on electrically heated models, an optional SmartElec3 control system consists of a base unit (installed within the air curtain) and a program panel that can be installed remote from the air curtain.

Usually, the program panel is mounted at a low level from the air curtain for user access and to a maximum distance of 100m.

The base unit and program panel are linked by a pre-wired low voltage cable as specified in these instructions.

The SmartElec3 factory fitted base unit provides terminals for 3 phase supply connection and the low voltage program panel cable. The SmartElec3 base unit rapidly pulses energy to the heating elements. This combined with the inbuilt intelligent sensor control, maintains a fixed outlet temperature, thereby reducing energy consumption

compared to an air curtain without the SmartElec3 control.



The programmer shown above is the same as used on standard air curtains and allows the user to control either a single air curtain, or a network of up to 16 air curtains, each with different settings if required, and provides the following functions:-

- Heat On or Off
- Off or Low, Medium and High Fan Speeds
- Air Outlet Temperature.

For further details please refer to section 10.2



### Note

Neither asbestos nor soft soldered joints are used in the construction or manufacture of the Airbloc AC Commercial and Retail Air Curtain range. The materials selected for use can withstand the mechanical, chemical, and thermal stresses which they will be subject to during foreseen normal use when installed in accordance with the manufacturers recommendations.

## 1.4 Model Definitions

AC1000xxxx = AC Airbloc 1M in length. 1500=1.5M; 2000=2.0M

ACxxxxSxxx = AC Airbloc Standard Capacity (up to 3M from floor); H=High Capacity(up to 4m from floor)

ACxxxxxExx = AC Airbloc Electrically heated. A=Ambient; W=LPHW coils.

ACxxxxx12 = AC Airbloc 12kW coils. 6=6kW; 9=9kW; 12=12kW; 18kW; 24=24kW.

-1ph suffix = AC Airbloc 230V Single phase supply (Std format =3pha)

-SM suffix = AC Airbloc SmartElec Energy Saving Controller (Std format=Standard AC/ACR Control)

e.g. AC2000HE24-SM = AC Airbloc Air Curtain, 2M long, 24kW electrically heated high capacity c/w SmartElec Control.

## 1.5 General requirements



### Caution

Before installation, check that the local distribution conditions, nature of water and pressure (LPHW), are compatible.

**Installation and assembly procedures must be carried out by suitable competent persons. Commissioning and service procedures must be carried out by suitable qualified persons.**



### Warning

Unauthorised modifications to the appliance, or departure from the manufacturers guidance on intended use, or, installation contrary to the manufacturers recommendations may constitute a hazard.



### Note

To ignore the warning and caution notices, and to ignore the advice from the manufacturer on installation, commissioning, servicing, or use, will jeopardise any applicable warranty, moreover, such a situation could also compromise the safe and efficient running of the appliance itself, and thereby constitute a hazard.

The installation of the appliance must meet all the relevant European, national, and local criteria.

Prior to installation the following points should be considered;

- The position and mounting height of the Air Curtain for the optimum efficient distribution.
- The position of the Air Curtain relative to the electrical services, and any controllers.
- The position of the Air Curtain relative to the low pressure hot water pipework where appropriate.
- The position of the heater relative to service and maintenance requirements.



### Caution

The air Curtain must not be installed within an area where the conditions are unsuitable, e.g. where the atmosphere is highly corrosive, has a high degree of salinity, or where high wind velocities may affect operation. Suitable protection should be provided for the appliance when it is located in a position where it may be susceptible to external mechanical damage.

## 1.6 Health and Safety



### Warning

Airbloc Air Curtains must be installed in accordance with any relevant and Regulations. Due account should be taken of any obligations arising from the Health and Safety at Works Act

1974 or relevant codes of practice. In addition the installation must be carried out in accordance with the current IEE wiring regulations and any other relevant British Standards and Codes of Practice by a qualified installer. Isolate all electrical supplies to the heater & controller before proceeding.



### Caution

For your own safety we recommend the use of Personal Protective Equipment when handling sharp or heavy items.

Sole liability rests with the installer to ensure that all site safety procedures are adhered to during installation.

Sole liability rests with the installer to ensure that Personal Protective Equipment is used during installation of the product.

Do not rest anything especially ladders against the product.

## 1.7 Delivery and pre-installation checks.

On receipt of the Air Curtain, the following checks should be carried out;

- The model is as per order.
- That it is undamaged.
- That it is suitable for the source water supply (LPHW).
- That it is suitable for the electrical supply.

If any of these points are not satisfied then contact should be made with the Sales Office at Nortek Global HVAC (UK) Ltd as soon as possible by telephoning 01384 489700. In the case of claims for damage, this must be signed for as damaged and reported in writing within 24 hours of delivery, in order to comply with insurance criteria.

## 1.8 Location



### WARNING:

**THIS AIR CURTAIN SHOULD NOT BE INSTALLED WHERE THERE IS A CORROSIVE ATMOSPHERE.**

Airbloc units should be installed horizontally directly over the door opening. It is recommended that the air curtain is installed on the inside of the building, within the open room space against a wall or ceiling. AC chassis units are designed to be positioned in suspended ceilings or bulkheads.

Care must be taken to allow complete free air movement into the inlet grilles of the unit to ensure correct working operation of the air curtain. The discharge opening should be as close to the top of the door as possible and to cover the entire door width.

Units can be mounted adjacent to each other to cover the full door opening across wider entrances.

These units are designed for surface mounting and should not be placed into a ceiling void, due to possible obstruction of airflow and difficulty in routine cleaning and maintenance.

## 1.9 Clearance distances

It is recommended that a minimum clearance of 300mm is allowed around the top and front of the unit. The clearance allows for cable entry and prevents combustible surfaces overheating.

The minimum mounting height (floor to grille outlet) is 1.8m. The recommended maximum mounting height is 3m for standard and 4m for high capacity models.

## 1.10 Electrical Supply

For full electrical loadings, please refer to the individual technical data sheets within this manual.

It is recommended that the electrical supply to the base unit in the air curtain is via an appropriate switched isolator in accordance with the regulations in force in the country of use and must be via a fused isolator having a contact separation of greater than 3mm in all poles.

BMS control, time switches, room thermostats and door interlocks can be installed at the discretion and responsibility of the installer.

All units must be wired in accordance with I.E.E regulations for the Electrical Equipment of Buildings and the installer should ensure that a suitable isolating switch is connected in the mains supply.



### Warning

For safety reasons a good earth connection must ALWAYS be made to the heater and control box.

### 1.10.1 Standard controller

Electrically heated supply is either 230V 1 phase (6 and 9kW options) or 415V 3 phase (9 to 24kW), Neutral and Earth. Max cable inlet size is 10mm<sup>2</sup> (refer to individual technical specification).

Ambient and LPHW supply is 230V 1 phase, Neutral and Earth. Max cable inlet size is 1.5mm<sup>2</sup>.

Keypad is wired to the base unit via a pre-wired cable fitted with RJ45 plugs.

### 1.10.2 SmartElec3 controller

Electrically heated supply is 415V 3 phase, neutral and earth. Max cable inlet size is 10mm<sup>2</sup>.

Keypad is wired to the base unit via a RJ45 pre-wired cable.

Networked air curtain interconnects via a RJ45 pre-wired cable.

## 2. Dimensions.

### 2.1 AC Air Curtain

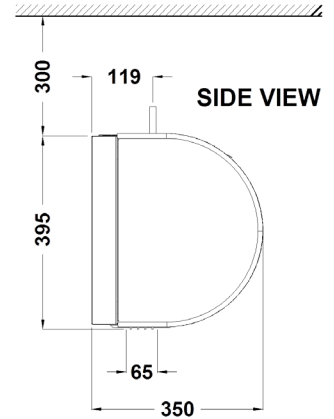
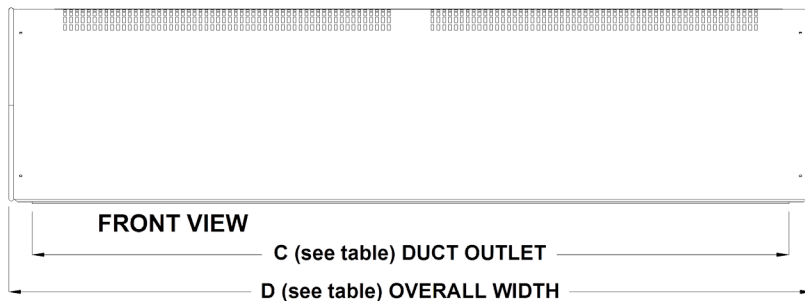
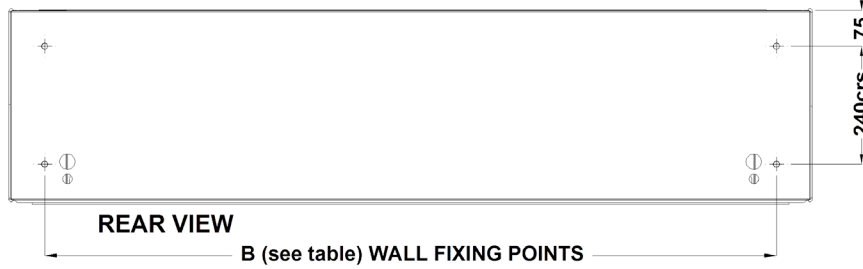
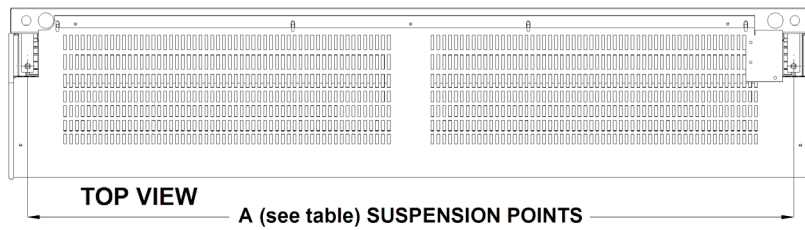

#### Dimensions

mm	1000	1500	2000
<b>A</b>	1062	1562	2062
<b>B</b>	992	1492	1992
<b>C</b>	1053	1553	2053
<b>D</b>	1138	1638	2138

### 2.2 CMS Chassis Air Curtain

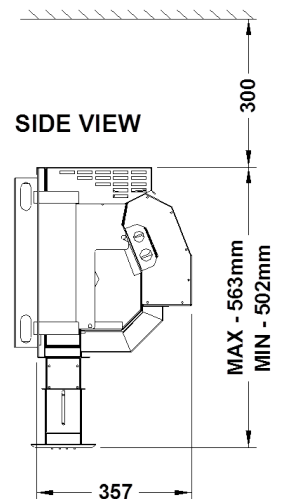
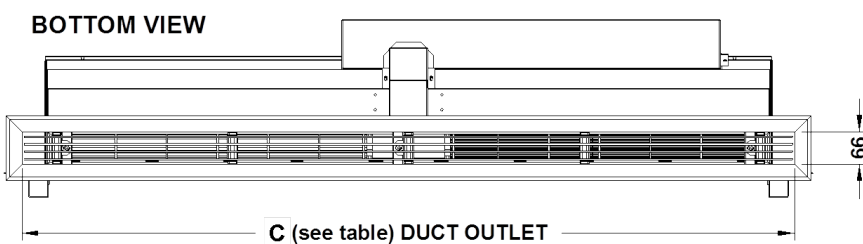
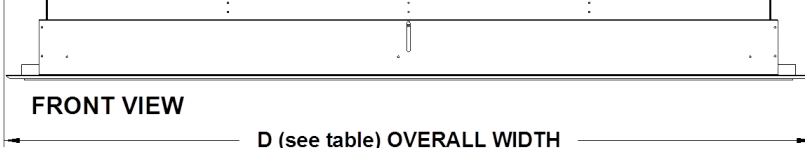
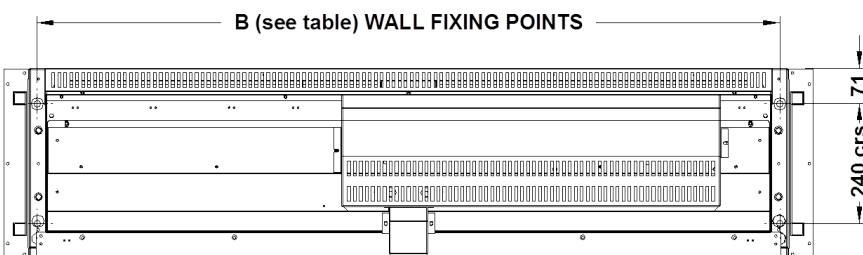
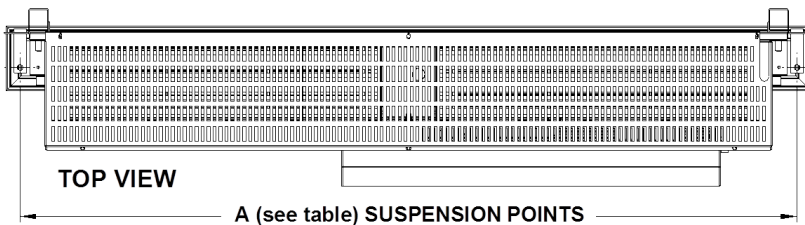

### 2.3 Program keypad dimensions

The keypad is supplied with an industry standard plastic double surface mounted socket box. Alternatively the keypad can be flush mounted using a customer supplied metal flush conduit box as shown below in Fig. 2.

**Fig.1. Surface mount box**

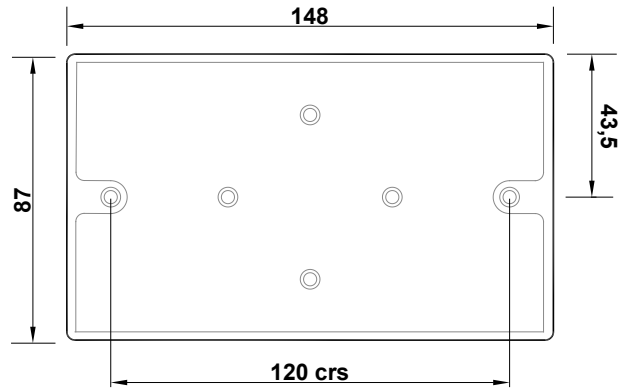

**Fig.2. Optional flush mounting using metal conduit box**

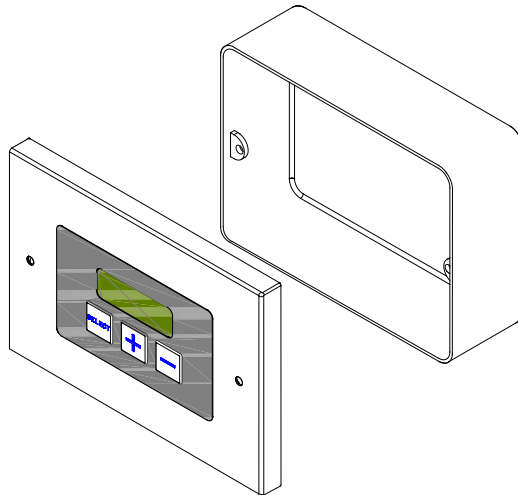

### 3. Technical Specifications.

3.1 (Single Phase only)			AC1000SE6-1PH	AC1500SE6-1PH	AC2000SE9-1PH
<b>General Data</b>					
Maximum height	M			3.0	
Door width		1.0		1.5	2.0
Heat Medium	kW			Electrical heated	
Heat settings			3 / 6		4.5 / 9
Fan type / dia				Crossflow / 150mm	
Fan settings				3 Speeds	
Switching type				3 tactile pushbuttons	
Weight	kg	39.5		49.0	60.0
<b>Electrical Data</b>					
Supply voltage				230V 1ph 50Hz	
Total load	kW (a)		6.4 (27.7)		9.4 (40.7)
Motor power	W			370	
Max Starting current*	amps			5.0	
Max Running current*	amps			2.1	
External fuse size amps	amps		32		45
Programmer keypad	pt.no.			108221-RJ45	
Program keypad control wiring				RJ45 (pre-wired cable required)	
Cable terminal size				10mm <sup>2</sup> MAX	
Mains terminal block position				Top of PCB (L1, N, E)	
RJ45 socket position				Centre of PCB (opposite mains input terminals)	
<b>Air Data</b>					
Air Volume	Low speed	m <sup>3</sup> /h	1300	1600	2900
	Medium speed	m <sup>3</sup> /h	1850	2400	4100
	High speed	m <sup>3</sup> /h	2300	3300	5000
Air Velocity	Low @ 0M	m/s		6.0	
	Medium @ 0M	m/s		8.5	
	High @ 0M	m/s		11.0	
	High @ 1M	m/s	5.4	5.5	5.2
	High @ 2M	m/s	3.6	3.7	3.6
	High @ 3M	m/s	2.6	2.5	2.4
	Delta T	Low speed	°C	20	13
	Medium speed	°C	13	9	10
	High speed	°C	11	7	7
Noise level @ 3M in free field	Low speed	dB(A)		50	
	Medium speed	dB(A)		55	
	High speed	dB(A)		60	
<b>Dimensional Data</b>					
Length	mm	1138		1638	2138
Depth (width)	mm			350	
Height including outlet	mm			395 (Chassis - min 502 max 563)	
Outlet length	mm	1095		1595	2095
Outlet depth	mm			65	
Outlet height	mm			Flush (Chassis - min 107 max 168)	
Drop rod mounting rear to centres on depth	mm			119	
Drop rod side to 1st Centre	mm			38	
Drop rod mounting centres on length	mm	1062		1562	2062
Wall mounting side to 1st centre	mm			73	
Wall mounting top to 1st centre	mm			75	
Wall mounting centres on length	mm	992		1492	1992
Wall mounting centres on height	mm			240	

\* Motor current only at high speed

3.2			AC1000SE9	AC1500SE12	AC2000SE18
<b>General Data</b>					
Maximum height		M		3.0	
Door width			1.0	1.5	2.0
Heat Medium		kW		Electrical heated	
Heat settings			4.5 / 9	6 / 12	9 / 18
Fan type / dia				Crossflow / 150mm	
Fan settings				3 Speeds	
Switching type				3 tactile pushbuttons	
Weight		kg	39.5	49.0	60.0
<b>Electrical Data</b>					
Supply voltage				415V 3ph 50Hz	
Total load		kW (a)	9.4 (13.1)	12.4 (17.3)	18.4 (25.6)
Motor power		W		370	
Max Starting current*		amps		5.0	
Max Running current*		amps		2.1	
External fuse size amps		amps	16	20	32
Programmer keypad		pt.no.		108221-RJ45	
Program keypad control wiring				RJ45 (pre-wired cable required)	
Cable terminal size				10mm <sup>2</sup> MAX	
Mains terminal block position				Top opf PCB ( L1, L2, L3, N, E)	
RJ45 socket position				Centre of PCB (opposite mains input terminals)	
** SmartElec3 Energy Saving Control				108221-RJ45	
SmartElec3 Energy Saving Control wiring				RJ45 (pre-wired cable required)	
Cable terminal size				10.0mm <sup>2</sup> Max	
Mains terminal block position				Top opf PCB ( L1, L2, L3, N, E)	
RJ45 socket position				Centre of PCB (opposite mains input terminals)	
<b>Air Data</b>					
Air Volume	Low speed	m <sup>3</sup> /h	1300	1600	2900
	Medium speed	m <sup>3</sup> /h	1850	2400	4100
	High speed	m <sup>3</sup> /h	2300	3300	5000
Air Velocity	Low @ 0M	m/s		6.0	
	Medium @ 0M	m/s		8.5	
	High @ 0M	m/s		11.0	
	High @ 1M	m/s	5.4	5.5	5.2
	High @ 2M	m/s	3.6	3.7	3.6
	High @ 3M	m/s	2.6	2.5	2.4
	Delta T	Low speed	°C	30	26
	Medium speed	°C	22	18	19
	High speed	°C	17	15	15
Noise level @ 3M in free field	Low speed	dB(A)		50	
	Medium speed	dB(A)		55	
	High speed	dB(A)		60	
<b>Dimensional Data</b>					
Length		mm	1138	1638	2138
Depth (width)		mm		350	
Height including outlet		mm		395 (Chassis - min 502 max 563)	
Outlet length		mm	1095	1595	2095
Outlet depth		mm		65	
Outlet height		mm		Flush (Chassis - min 107 max 168)	
Drop rod mounting rear to centres on depth		mm		119	
Drop rod side to 1st Centre		mm		38	
Drop rod mounting centres on length		mm	1062	1562	2062
Wall mounting side to 1st centre		mm		73	
Wall mounting top to 1st centre		mm		75	
Wall mounting centres on length		mm	992	1492	1992
Wall mounting centres on height		mm		240	

\* Motor current only at high speed

\*\*Suffix with -SM for SmartElec3 Energy Saving Control.

3.3		AC1000HE12	AC1500HE18	AC2000HE24	
<b>General Data</b>					
Maximum height	M		4.0		
Door width		1.0	1.5	2.0	
Heat Medium	kW		Electrical heated		
Heat settings		6 / 12	9 / 18	12 / 24	
Fan type / dia		Crossflow / 150mm			
Fan settings		3 Speeds			
Switching type		3 tactile pushbuttons			
Weight	kg	39.5	49.0	60.0	
<b>Electrical Data</b>					
Supply voltage		415V 3ph 50Hz			
Total load	kW (a)	12.4 (17.3)	18.4 (25.6)	24.4 (34.0)	
Motor power	W	370			
Max Starting current*	amps	5.0			
Max Running current*	amps	2.1			
External fuse size amps	amps	20	32	40	
Programmer keypad	pt.no.	108221-RJ45			
Program keypad control wiring		RJ45 (pre-wired cable required)			
Cable terminal size		10.0mm <sup>2</sup> MAX			
Mains terminal block position		Top of PCB ( L1, L2, L3, N, E)			
RJ45 socket position		Centre of PCB (opposite mains input terminals)			
** SmartElec3 Energy Saving Control		108221-RJ45			
SmartElec3 Energy Saving Control wiring		RJ45 (pre-wired cable required)			
Cable terminal size		10.0mm <sup>2</sup> Max			
Mains terminal block position		Top of PCB (L1, L2, L3, N, E)			
RJ45 socket position		Centre of PCB (opposite mains input terminals)			
<b>Air Data</b>					
Air Volume	Low speed	m <sup>3</sup> /h	1300	1600	2900
	Medium speed	m <sup>3</sup> /h	1850	2400	4100
	High speed	m <sup>3</sup> /h	2300	3300	5000
Air Velocity	Low @ 0M	m/s	6.0		
	Medium @ 0M	m/s	8.5		
	High @ 0M	m/s	11.0		
	High @ 1M	m/s	5.4	5.5	5.2
	High @ 2M	m/s	3.6	3.7	3.6
	High @ 3M	m/s	2.6	2.5	2.4
	High @ 4M	m/s	1.5	1.6	1.4
	Delta T	Low speed	°C	35	35
Medium speed		°C	28	27	26
High speed		°C	22	22	20
Noise level @ 3M in free field	Low speed	dBA	50		
	Medium speed	dBA	55		
	High speed	dBA	60		
<b>Dimensional Data</b>					
Length	mm	1138	1638	2138	
Depth (width)	mm	350			
Height including outlet	mm	395 (Chassis - min 502 max 563)			
Outlet length	mm	1095	1595	2095	
Outlet depth	mm	65			
Outlet height	mm	Flush (Chassis - min 107 max 168)			
Drop rod mounting rear to centres on depth	mm	119			
Drop rod side to 1st Centre	mm	38			
Drop rod mounting centres on length	mm	1062	1562	2062	
Wall mounting side to 1st centre	mm	73			
Wall mounting top to 1st centre	mm	75			
Wall mounting centres on length	mm	992	1492	1992	
Wall mounting centres on height	mm	240			

\* Motor current only at high speed

\*\*Suffix with -SM for SmartElec3 Energy Saving Control.

3.4			AC1000SA	AC1500SA	AC2000SA
<b>General Data</b>					
Maximum height		M		3.0	
Door width			1.0	1.5	2.0
Heat Medium		kW		Ambient	
Fan type / dia				Crossflow / 150mm	
Fan settings				3	
Switching type				3 tactile pushbuttons	
Weight		kg	39.5	49.0	60.0
<b>Electrical Data</b>					
Supply voltage				230V 1ph 50Hz	
Total load		kW (a)		0.4 (1.61)	
Motor power		W		370	
Max Starting current*		amps		5.0	
Max Running current*		amps		2.1	
External fuse size amps		amps		10	
Programmer keypad		pt.no.		108221-RJ45	
Program keypad control wiring				RJ45 (pre-wired cable required)	
Cable terminal size				1.5mm <sup>2</sup> MAX	
Mains terminal block position				Top right of PCB (L1, N, E)	
RJ45 socket position				Right hand side of PCB (below mains input terminals)	
<b>Air Data</b>					
Air Volume	Low speed	m <sup>3</sup> /h	1300	1600	2900
	Medium speed	m <sup>3</sup> /h	1850	2400	4100
	High speed	m <sup>3</sup> /h	2300	3300	5000
Air Velocity	Low @ 0M	m/s		6.0	
	Medium @ 0M	m/s		8.5	
	High @ 0M	m/s		11.0	
	High @ 1M	m/s	5.4	5.5	5.2
	High @ 2M	m/s	3.6	3.7	3.6
	High @ 3M	m/s	2.6	2.5	2.4
Noise level @ 3M in free field	Low speed	dB(A)		50	
	Medium speed	dB(A)		55	
	High speed	dB(A)		60	
<b>Dimensional Data</b>					
Length		mm	1138	1638	2138
Depth (width)		mm		350	
Height including outlet		mm		395 (Chassis - min 502 max 563)	
Outlet length		mm	1095	1595	2095
Outlet depth		mm		65	
Outlet height		mm		Flush (Chassis - min 107 max 168)	
Drop rod mounting rear to centres on depth		mm		119	
Drop rod side to 1st Centre		mm		38	
Drop rod mounting centres on length		mm	1062	1562	2062
Wall mounting side to 1st centre		mm		73	
Wall mounting top to 1st centre		mm		75	
Wall mounting centres on length		mm	992	1492	1992
Wall mounting centres on height		mm		240	

\* Motor current only at high speed

3.5			AC1000HA	AC1500HA	AC2000HA
<b>General Data</b>					
Maximum height	M			4.0	
Door width			1.0	1.5	2.0
Heat Medium	kW		Ambient		
Fan type / dia			Crossflow / 150mm		
Fan settings			3		
Switching type			3 tactile pushbuttons		
Weight	kg		39.5	49.0	60.0
<b>Electrical Data</b>					
Supply voltage			230V 1ph 50Hz		
Total load	kW (a)		0.4 (1.61)		
Motor power	W		370		
Max Starting current*	amps		5.0		
Max Running current*	amps		2.1		
External fuse size amps	amps		10		
Programmer keypad	pt.no.		108221-RJ45		
Program keypad control wiring			RJ45 (pre-wired cable required)		
Cable terminal size			1.5mm <sup>2</sup> MAX		
Mains terminal block position			Top right of PCB (L1, N, E)		
RJ45 socket position			Right hand side of PCB (below mains input terminals)		
<b>Air Data</b>					
Air Volume	Low speed	m <sup>3</sup> /h	1300	1600	2900
	Medium speed	m <sup>3</sup> /h	1850	2400	4100
	High speed	m <sup>3</sup> /h	2300	3300	5000
Air Velocity	Low @ 0M	m/s		6.0	
	Medium @ 0M	m/s		8.5	
	High @ 0M	m/s		11.0	
	High @ 1M	m/s	5.4	5.5	5.2
	High @ 2M	m/s	3.6	3.7	3.6
	High @ 3M	m/s	2.6	2.5	2.4
	High @ 4M	m/s	1.5	1.6	1.4
Noise level @ 3M in free field	Low speed	dB(A)		50	
	Medium speed	dB(A)		55	
	High speed	dB(A)		60	
<b>Dimensional Data</b>					
Length	mm		1138	1638	2138
Depth (width)	mm		350		
Height including outlet	mm		395 (Chassis - min 502 max 563)		
Outlet length	mm		1095	1595	2095
Outlet depth	mm		65		
Outlet height	mm		Flush (Chassis - min 107 max 168)		
Drop rod mounting rear to centres on depth	mm		119		
Drop rod side to 1st Centre	mm		38		
Drop rod mounting centres on length	mm		1062	1562	2062
Wall mounting side to 1st centre	mm		73		
Wall mounting top to 1st centre	mm		75		
Wall mounting centres on length	mm		992	1492	1992
Wall mounting centres on height	mm		240		

\* Motor current only at high speed

3.6			AC1000SW9	AC1500SW12	AC2000SW18
<b>General Data</b>					
Maximum height		M		3.0	
Door width			1.0	1.5	2.0
Heat Medium		kW		LPHW	
Heat settings			9	12	18
Fan type / dia				Crossflow / 150mm	
Fan settings				3	
Switching type				3 tactile pushbuttons	
Weight		kg	39.5	49.0	60.0
<b>Electrical Data</b>					
Supply voltage				230V 1ph 50Hz	
Total load		kW (a)		0.4 (1.61)	
Motor power		W		370	
Max Starting current*		amps		5.0	
Max Running current*		amps		2.1	
External fuse size amps		amps		10	
Programmer keypad		pt.no.		108221-RJ45	
Program keypad control wiring				RJ45 (pre-wired cable required)	
Cable terminal size				1.5mm <sup>2</sup> MAX	
Mains terminal block position				Top right of PCB (L1, N, E)	
RJ45 socket position				Right hand side of PCB (below mains input terminals)	
<b>Air Data</b>					
Air Volume	Low speed	m <sup>3</sup> /h	1300	1600	2900
	Medium speed	m <sup>3</sup> /h	1850	2400	4100
	High speed	m <sup>3</sup> /h	2300	3300	5000
Air Velocity	Low @ 0M	m/s		6.0	
	Medium @ 0M	m/s		8.5	
	High @ 0M	m/s		11.0	
	High @ 1M	m/s	5.4	5.5	5.2
	High @ 2M	m/s	3.6	3.7	3.6
	High @ 3M	m/s	2.6	2.5	2.4
Delta T	Low speed	°C	30	26	27
	Medium speed	°C	22	18	19
	High speed	°C	17	15	15
Noise level @ 3M in free field	Low speed	dBA		50	
	Medium speed	dBA		55	
	High speed	dBA		60	
<b>LPHW Data</b>					
LPHW flow		l/s	0.20	0.27	0.40
Fluid pressure drop		kPA	23	15	
Flow & return connection		mm		15	
Inlet temperature		°C		82	
Outlet temperature		°C		71	
<b>Dimensional Data</b>					
Length		mm	1138	1638	2138
Depth (width)		mm		350	
Height including outlet		mm		395 (Chassis - min 502 max 563)	
Outlet length		mm	1095	1595	2095
Outlet depth		mm		65	
Outlet height		mm		Flush (Chassis - min 107 max 168)	
Drop rod mounting rear to centres on depth		mm		119	
Drop rod side to 1st Centre		mm		38	
Drop rod mounting centres on length		mm	1062	1562	2062
Wall mounting side to 1st centre		mm		73	
Wall mounting top to 1st centre		mm		75	
Wall mounting centres on length		mm	992	1492	1992
Wall mounting centres on height		mm		240	

3.7			AC1000HW12	AC1500HW18	AC2000HW24
<b>General Data</b>					
Maximum height		M		4.0	
Door width			1.0	1.5	2.0
Heat Medium		kW		LPHW	
Heat settings			12	18	24
Fan type / dia				Crossflow / 150mm	
Fan settings				3	
Switching type				3 tactile pushbuttons	
Weight		kg	39.5	49.0	60.0
<b>Electrical Data</b>					
Supply voltage				230V 1ph 50Hz	
Total load		kW (a)		0.4 (1.61)	
Motor power		W		370	
Max Starting current*		amps		5.0	
Max Running current*		amps		2.1	
External fuse size amps		amps		10	
Programmer keypad		pt.no.		108221-RJ45	
Program keypad control wiring				RJ45 (pre-wired cable required)	
Cable terminal size				1.5mm <sup>2</sup> MAX	
Mains terminal block position				Top right of PCB (L1, N, E)	
RJ45 socket position				Right hand side of PCB (below mains input terminals)	
<b>Air Data</b>					
Air Volume	Low speed	m <sup>3</sup> /h	1300	1600	2900
	Medium speed	m <sup>3</sup> /h	1850	2400	4100
	High speed	m <sup>3</sup> /h	2300	3300	5000
Air Velocity	Low @ 0M	m/s		6.0	
	Medium @ 0M	m/s		8.5	
	High @ 0M	m/s		11.0	
	High @ 1M	m/s	5.4	5.5	5.2
	High @ 2M	m/s	3.6	3.7	3.6
	High @ 3M	m/s	2.6	2.5	2.4
	High @ 4M	m/s	1.5	1.6	1.4
Delta T	Low speed	°C	35	35	36
	Medium speed	°C	28	27	26
	High speed	°C	22	22	20
Noise level @ 3M in free field	Low speed	dBA		50	
	Medium speed	dBA		55	
	High speed	dBA		60	
<b>LPHW Data</b>					
LPHW flow		l/s	0.27	0.40	0.53
Fluid pressure drop		kPA	19	23	24
Flow & return connection		mm		15	
Inlet temperature		°C		82	
Outlet temperature		°C		71	
<b>Dimensional Data</b>					
Length		mm	1138	1638	2138
Depth (width)		mm		350	
Height including outlet		mm		395 (Chassis - min 502 max 563)	
Outlet length		mm	1095	1595	2095
Outlet depth		mm		65	
Outlet height		mm		Flush (Chassis - min 107 max 168)	
Drop rod mounting rear to centres on depth		mm		119	
Drop rod side to 1st Centre		mm		38	
Drop rod mounting centres on length		mm	1062	1562	2062
Wall mounting side to 1st centre		mm		73	
Wall mounting top to 1st centre		mm		75	
Wall mounting centres on length		mm	992	1492	1992
Wall mounting centres on height		mm		240	

<b>3.8</b>	<b>Standard Controller</b>
<b>General Data</b>	
Sensor Input	NTC
Protection	1 x 1A fuse for the protection of the fan switching devices.
Fan Output	3 off Relay for High, Medium and Low Fan setting 3A max 240Vac
Connections	Screw terminals 4 for supply, 6 for elements output, 4 for fan output, 2 for BMS (time) control, 2 for sensor input, 2 for external thermal trip, 2 for external door switch, 2 for 0-10v fan option, 2 for 0-5v fault output, 2 for filter blocked, 2 for unit temperature.
Supply	230V 1Ph or 415 3Ph dependent on model type.
Dimensions	Program panel 146mm(L) x 85mm(W) x 38mm(D) max.
Temperature	5 to 50 °C operating; -20 to 65 °C storage
Display	Three 7-segment LCD red for parameter display
Push Buttons	3 positive feedback tactile push buttons

<b>3.9</b>	<b>SmartElec3 Controller</b>
<b>General Data</b>	
Sensor Input	NTC
Control Setpoint	16 to 35 °C in steps of 1 degree
Temperature Control	Proportional with 1°C hysteresis
Minimum Power	0% to 99 %
Cycle Time	2 seconds fixed
Protection	2 x high speed fuse for the protection of the heater switching devices
Fan Output	3 off Relay for High, Medium and Low Fan setting 3A max 240Vac
Connections	Screw terminals 5 for supply, 3 for heater output, 4 for fan output, 2 for BMS (time) control, 2 for sensor input, 2 for external thermal trip, 2 for external sensor, 2 for door, 2 for cooling fan on 24kW models. RJ45 comms connection to base unit via pre-wired cable.
Supply	415 V rms +/-15% 50/60Hz 5VA max.
Dimensions	Program panel 146mm(L) x 85mm(W) x 38mm(D) max.
Temperature	5 to 50 °C operating; -20 to 65 °C storage
Display	Three 7-segment LCD red for parameter display
Push Buttons	3 positive feedback tactile push buttons

3.10	LPHW/Ambient Controls
<b>General Data</b>	
Sensor Input	NTC
Control Setpoint	16 to 35 °C in steps of 1 degree
Temperature Control	0-10v valve output (proportional)
Cycle Time	2 seconds fixed
Protection	1 x 1A fuse for the protection of the mains input
Fan Output	3 off Relays for High, Medium and Low Fan setting 3A max 230Vac
Connections	Screw terminals 3 for mains supply, 4 for fan output, 2 for BMS (time) control, 2 for sensor input, 2 for external thermal trip, 2 for external sensor, 2 for door., 2 for 0-10v motor drive, 2 for 0-10v fan option, 2 for 0-5v fault output, 2 for pipe cold input, 2 for unit temperature input, RJ45 comms connection to base unit via pre-wired cable.
Supply	230 V 50/60Hz.
Dimensions	Program panel 146mm(L) x 85mm(W) x 38mm(D) max.
Temperature	5 to 50 °C operating; -20 to 65 °C storage
Display	Three 7-segment LCD red for parameter display
Push Buttons	3 positive feedback tactile push buttons

## 4. Wiring Diagrams.

### 4.1 Installer Wiring - Electrically Heated 6 & 9kW SINGLE PHASE ONLY

The program panel is connected to the base unit via a pre-wired RJ45 cable max length 100m.



It is recommended that this cable is run separately within its own trunking to avoid external interference.

External switch inputs (eg Timer) to be volt free and wired via normally open contacts to terminal pair marked eg. 'timer' (contacts closed to enable). Remove relevant factory fitted jumper for any optional input.

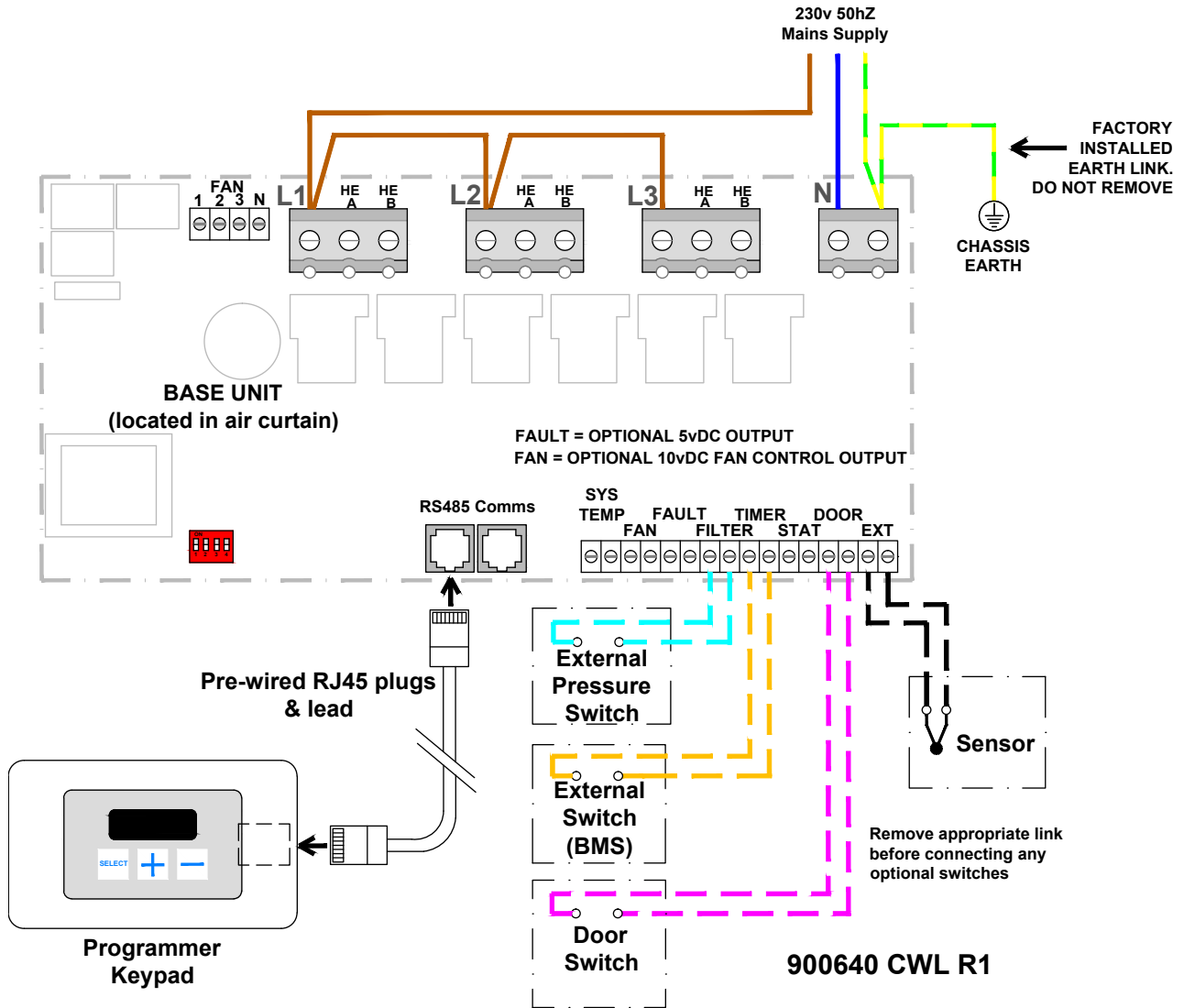

Terminal	Description	Cable	PCB Terminal	Description	Cable
N	Neutral	10mm <sup>2</sup> max	Ext	Option internal/external sensor (supplied)	1.5mm <sup>2</sup> max
L1	Phase 1 (or 1 Phase supply)		Filter block	Option filter blocked switch	
Pcb Terminal	Description	Cable	Fail o/p	Fault output (0-5v)	
Door	Option door contact	1.5mm <sup>2</sup> max	Fan	Option 0-10v fan output	
Timer BMS	Option external switch		Pcb Fuses	Rating (A)	
			F1	T1H (slow blow)	

#### Protection

External circuit breaker with the appropriate rating should be installed for the protection of the installation.

## 4.2 Installer Wiring - Electrically Heated 9, 12 & 18kW THREE PHASE ONLY

The program panel is connected to the base unit via a pre-wired RJ45 cable max length 100m.

 It is recommended that this cable is run separately within its own trunking to avoid external interference.

External switch inputs (eg Timer) to be volt free and wired via normally open contacts to terminal pair marked 'timer' (contacts closed to enable). Remove relevant factory fitted jumper for any optional input.

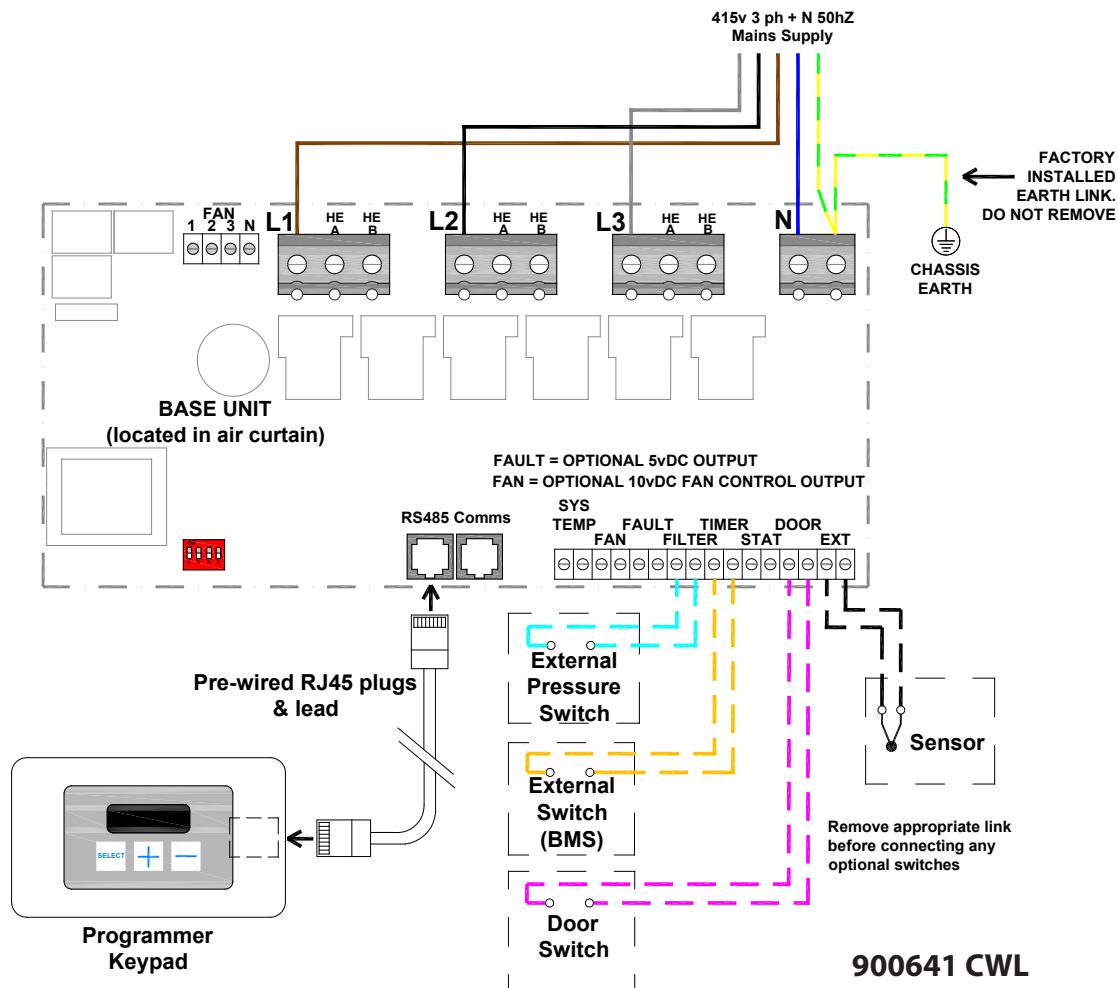

Terminal	Description	Cable
N	Neutral	10mm <sup>2</sup> max
L1	Phase 1	
L2	Phase 2	
L3	Phase 3	
Pcb Terminal	Description	Cable
Door	Option door contact	1.5mm <sup>2</sup> max
Timer/BMS	Option external switch	

PCB Terminal	Description	Cable
Ext	Option internal/external sensor (supplied)	1.5mm <sup>2</sup> max
Filter block	Option filter blocked switch	
Fail o/p	Fault output (0-5v)	
Fan	Option 0-10v fan output	
Pcb Fuses	Rating (A)	
F1	T1H (slow blow)	

### Protection

External circuit breaker with the appropriate rating should be installed for the protection of the installation.

### 4.3 Installer Wiring - Electrically Heated 24kW THREE PHASE ONLY

The program panel is connected to the base unit via a pre-wired RJ45 cable max length 100m.

 It is recommended that this cable is run separately within its own trunking to avoid external interference.

External switch inputs (eg Timer) to be volt free and wired via normally open contacts to terminal pair marked 'timer' (contacts closed to enable). Remove relevant factory fitted jumper for any optional input.

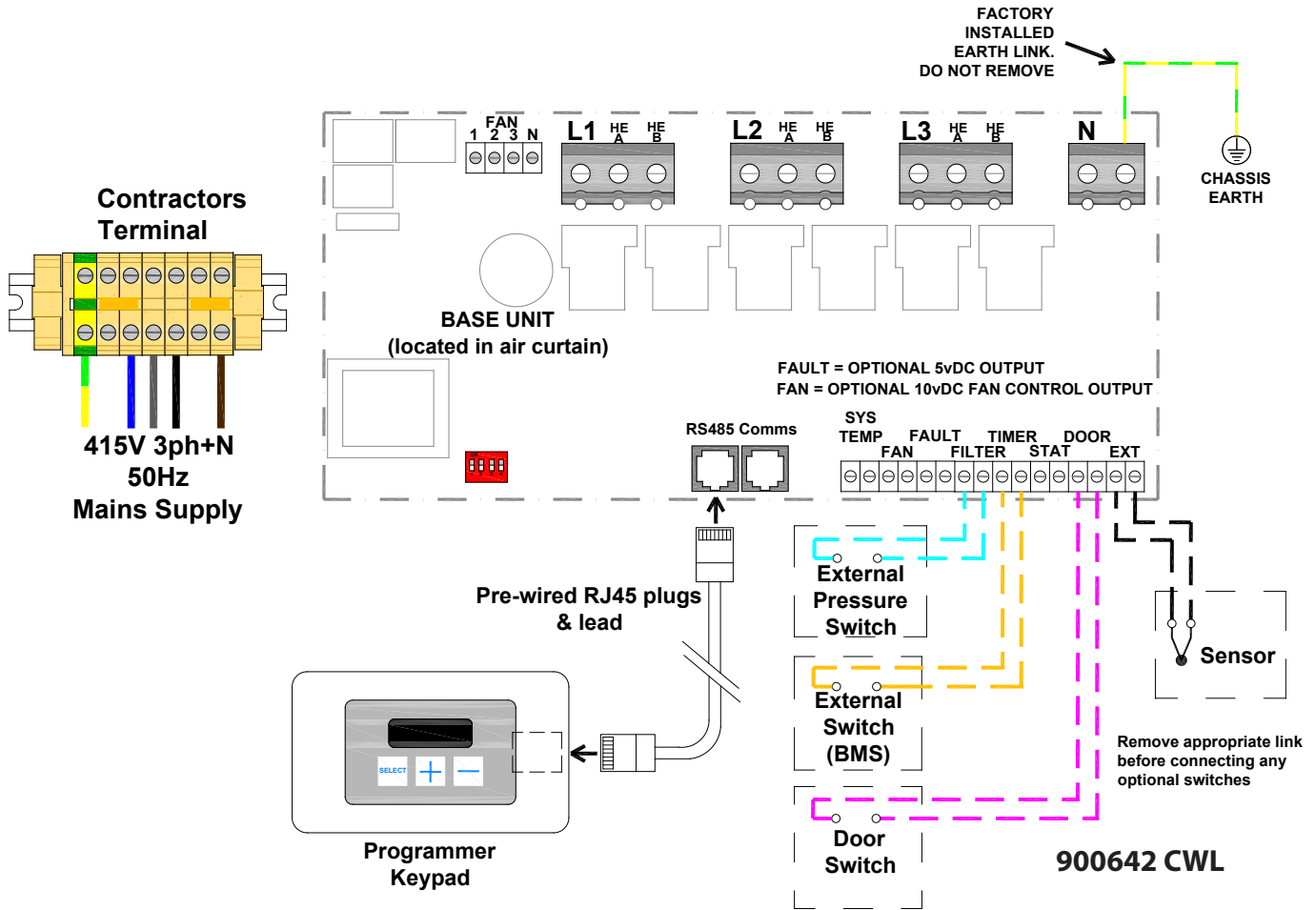

Terminal	Description	Cable
N	Neutral	10mm <sup>2</sup> max
L1	Phase 1	
L2	Phase 2	
L3	Phase 3	
Pcb Terminal	Description	Cable
Door	Option door contact	1.5mm <sup>2</sup> max
Timer/BMS	Option external switch	

PCB Terminal	Description	Cable
Ext	Option internal/external sensor (supplied)	1.5mm <sup>2</sup> max
Filter block	Option filter blocked switch	
Fail o/p	Fault output (0-5v)	
Fan	Option 0-10v fan output	
Pcb Fuses	Rating (A)	
F1	T1H (slow blow)	

#### Protection

External circuit breaker with the appropriate rating should be installed for the protection of the installation.

## 4.4 Installer Wiring - Ambient

The program panel is connected to the base unit via a pre-wired RJ45 cable max length 100m.



It is recommended that this cable is run separately within its own trunking to avoid external interference.

External switch inputs (eg Timer) to be volt free and wired via normally open contacts to terminal pair marked 'timer' (contacts closed to enable). Remove relevant factory fitted jumper for any optional input.

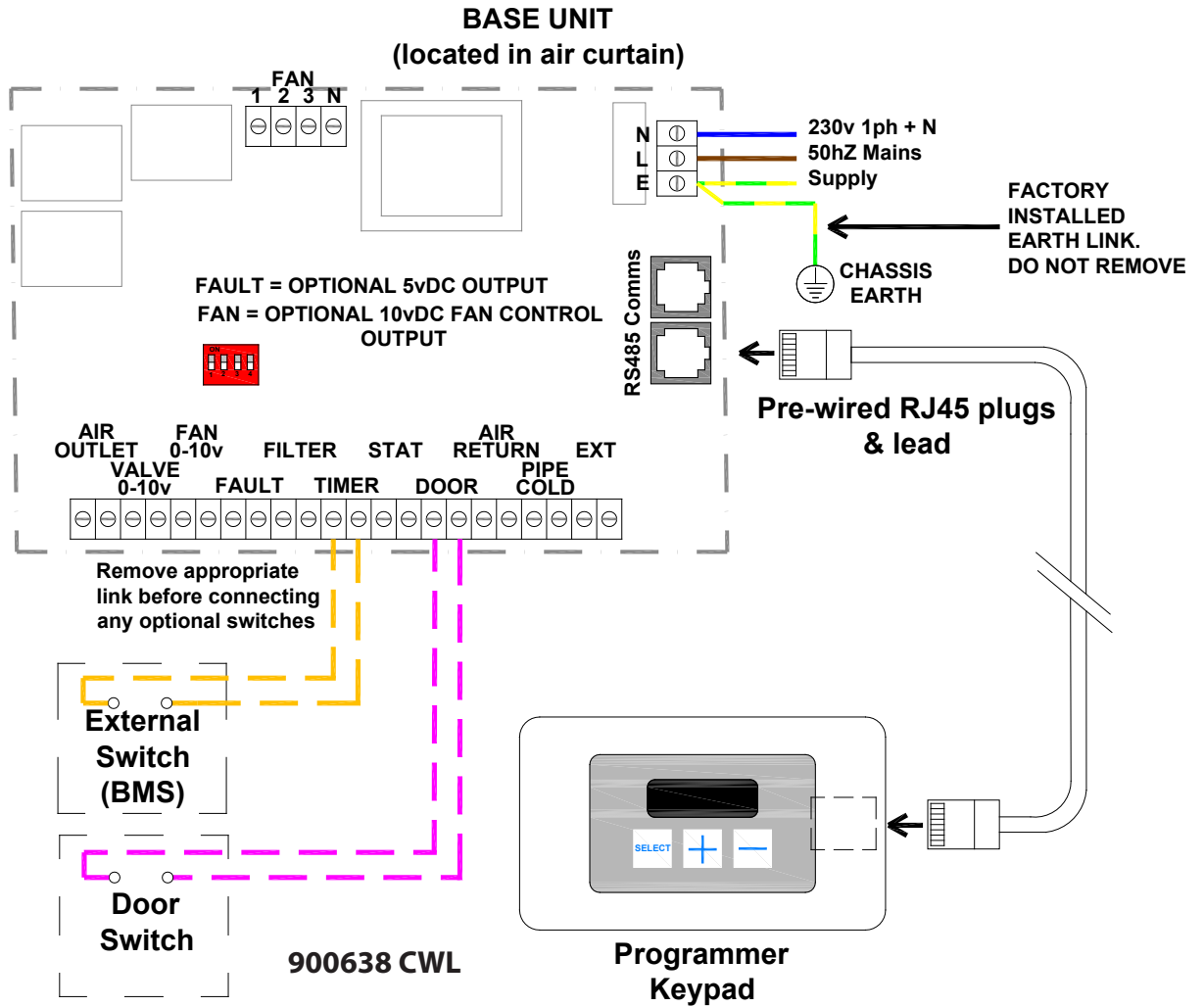

Terminal	Description	Cable
N	Neutral	1.5mm <sup>2</sup> max
L	1 Phase supply	
Pcb Terminal	Description	
Door	Option door contact	
Timer BMS	Option external switch	
Ext	Option internal/external sensor (*supplied)	

Terminal	Description	Cable
Filter block	Option filter blocked switch	1.5mm <sup>2</sup> max
Fail o/p	Fault output (0-5v)	
Fan 0-10v	Option 0-10v fan output	
Valve 0-10v	Option 0-10v valve output	
Pcb Fuses	Rating (A)	
F1	T1H (slow blow)	

### Protection

External circuit breaker with the appropriate rating should be installed for the protection of the installation.

## 4.5 Installer Wiring - LPHW

The program panel is connected to the base unit via a pre-wired RJ45 cable max length 100m.

 It is recommended that this cable is run separately within its own trunking to avoid external interference.

External switch inputs (eg Timer) to be volt free and wired via normally open contacts to terminal pair marked 'timer' (contacts closed to enable). Remove relevant factory fitted jumper for any optional input.

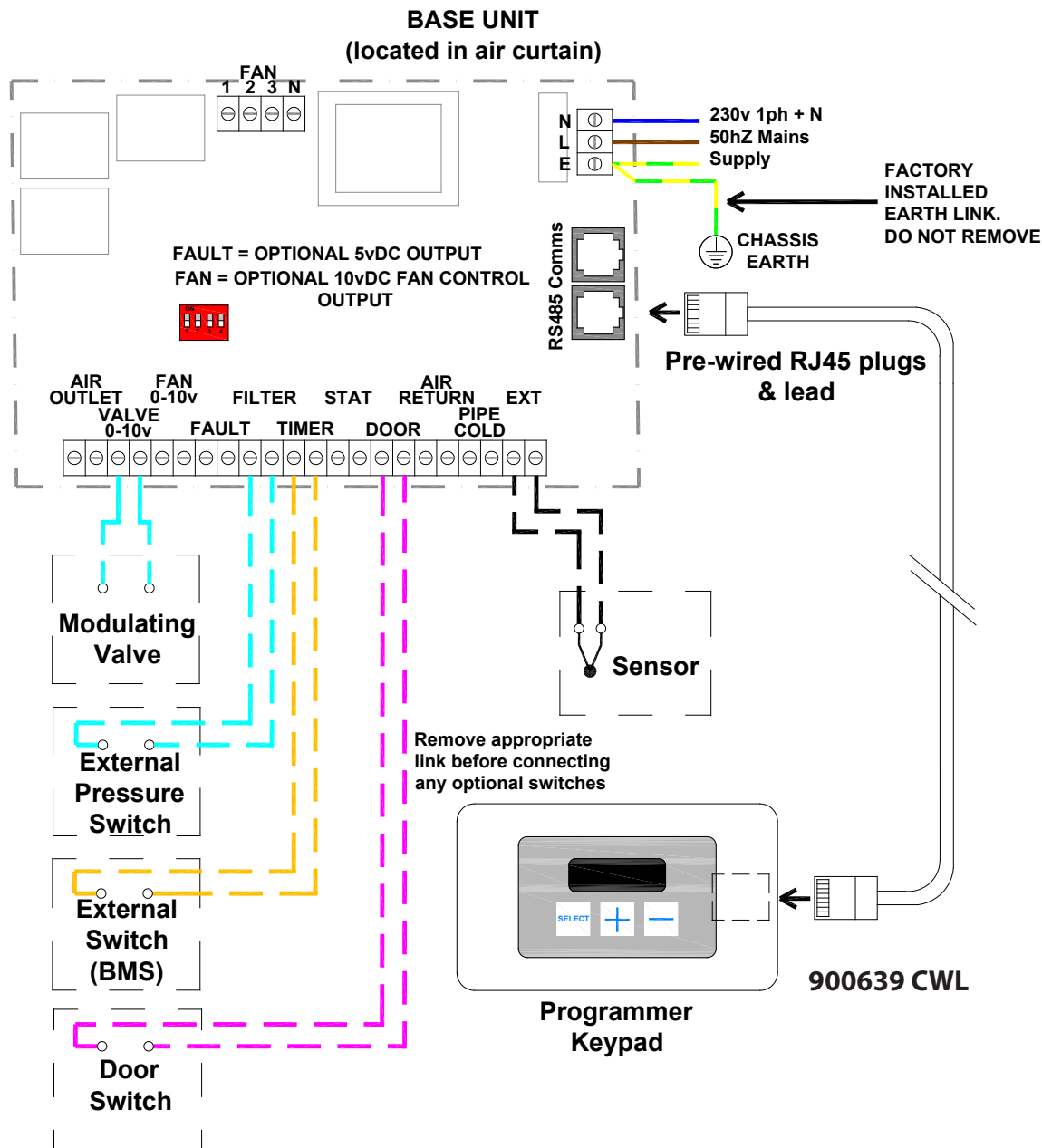

Terminal	Description	Cable
N	Neutral	1.5mm <sup>2</sup> max
L	1 Phase supply	
<b>Pcb Terminal</b>	<b>Description</b>	
<b>Door</b>	Option door contact	
<b>Timer BMS</b>	Option external switch	
<b>Ext</b>	Internal/external sensor (supplied)	
<b>Air return</b>	Option sensor	

Terminal	Description	Cable
<b>Pipe cold</b>	Option sensor	1.5mm <sup>2</sup> max
<b>Fail o/p</b>	Fault output (0-5v)	
<b>Fan</b>	Option 0-10v fan output	
<b>Valve</b>	Option 0-10v valve output	
<b>Filter block</b>	Option filter blocked switch	
<b>Pcb Fuses</b>	<b>Rating (A)</b>	
<b>F1</b>	T1H (slow blow)	

## 4.6 Factory Wiring - Electrically heated 6/9kW SINGLE PHASE ONLY

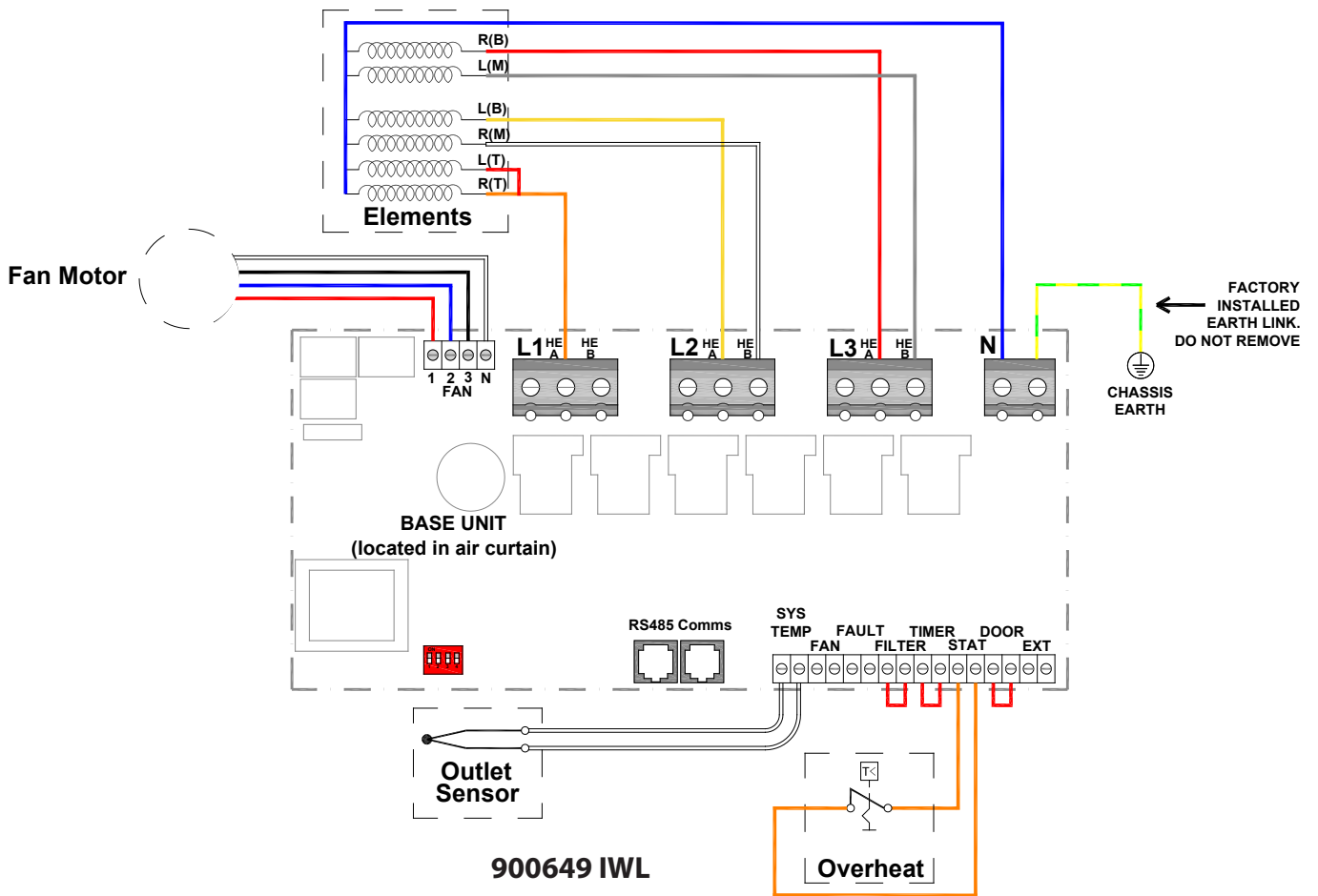

The element output is connected to the terminal blocks marked "L1 A", "L2 A&B", L3 A&B"

The fan output is connected to a 4 way connector marked "Fan 1, 2, 3 & N"

The thermal trip is connected to a 2 way connector marked "Stat"

Terminal	Description
N	Neutral
L	1 Phase supply
L1A,L2 A&B	2 thirds heating elements
L3 A&B	1 third heating elements
Pcb Terminal	Description
Stat	Thermal overheat trip
Ext	Internal/external sensor (supplied)
Fan 1	Fan - Low speed
Fan 2	Fan - medium speed
Fan 3	Fan - high speed
Filter	Factory link
Timer	Factory link
Door	Factory link

## 4.7 Factory Wiring - Electrically heated (up to 18kW) THREE PHASE ONLY

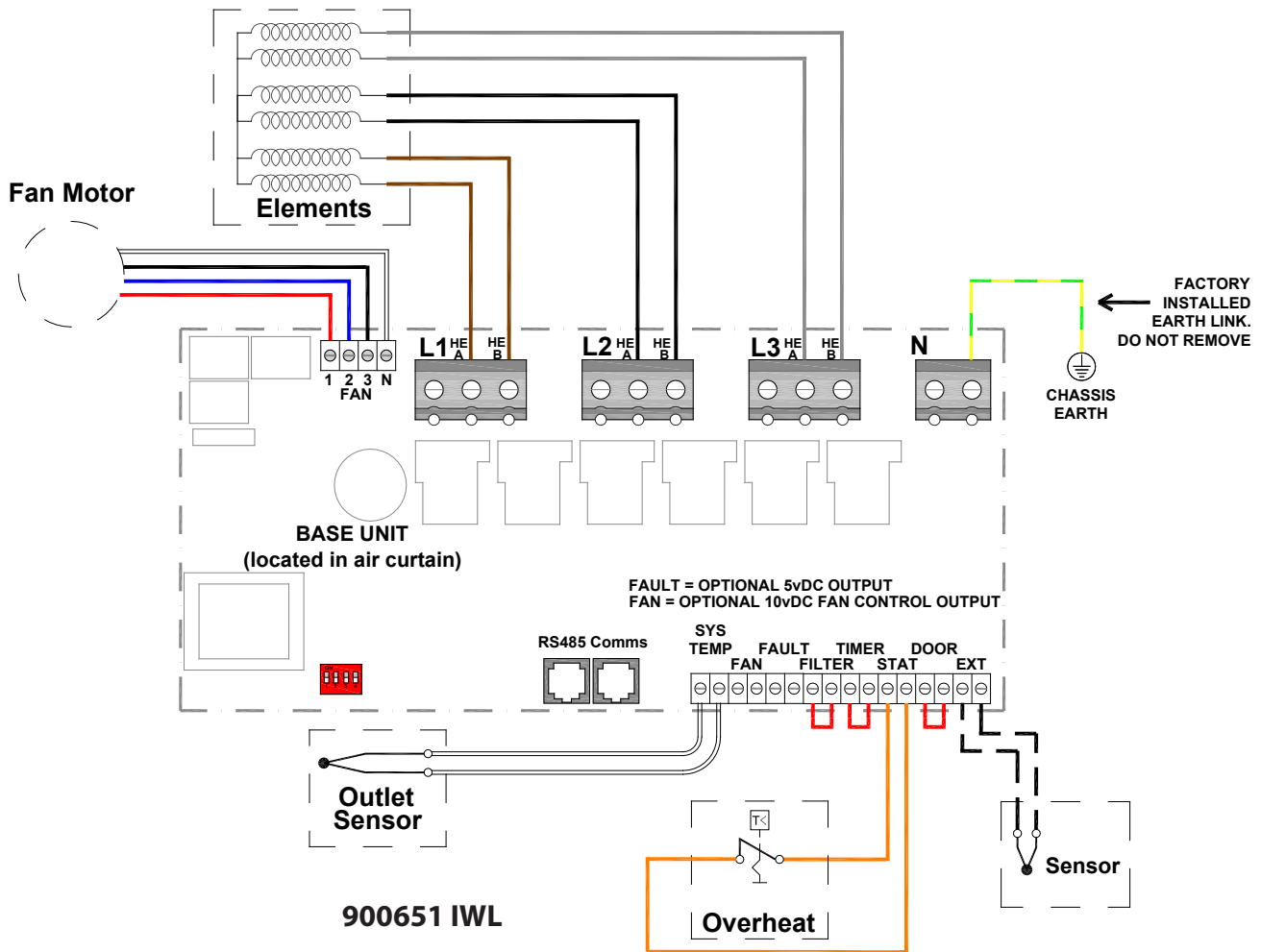

The element output is connected to the right and left side of each terminal block marked "HE A" & "HE B"

The fan output is connected to a 4 way connector marked "Fan 1,2,3 & N"

The thermal trips are connected to a 2 way connector marked "Stat"

Terminal	Description
L1,L2 & L3 HE A	One half of heating elements
L1,L2 & L3 HE B	Second half of heating elements
Pcb Terminal	Description
Stat	Thermal Overheat trip
Ext	Internal/external sensor (supplied)
Fan 1	Fan - low speed
Fan 2	Fan - medium speed
Fan 3	Fan - high speed
Filter	Factory link
Timer	Factory link
Door	Factory link

## 4.8 Factory Wiring - Electrically heated 24KW THREE PHASE ONLY

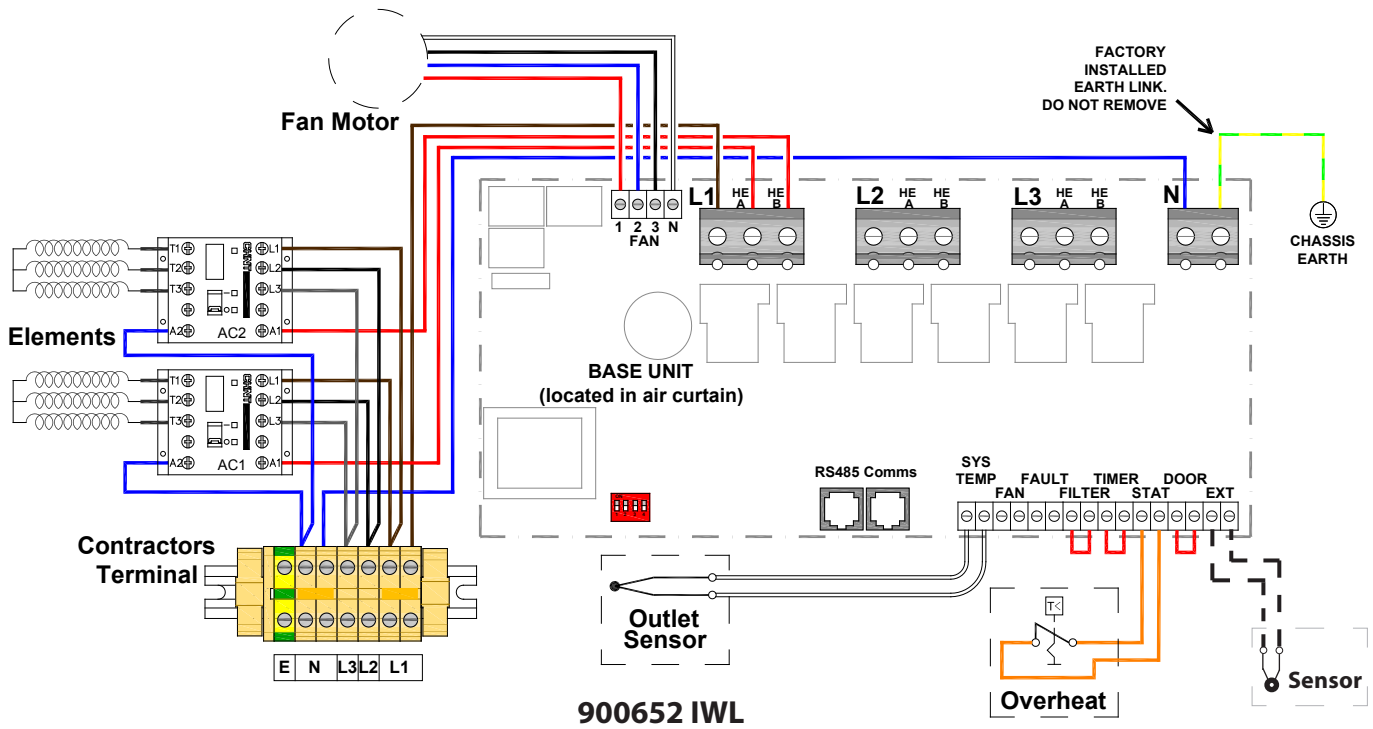

The element output is connected to the right and left side of each terminal block marked "HE A" & "HE B"

The fan output is connected to a 4 way connector marked "Fan 1,2,3 & N"

The thermal trip is connected to a 2 way connector marked "Stat"

Terminal	Description
L1 (PCB)	Live input
N (PCB)	Neutral
Pcb Terminal	Description
HEA	Heat setting 1 output
HEB	Heat setting 2 output
Stat	Thermal Overheat trip
Ext	Internal/external sensor (supplied)
Fan 1	Fan - low speed
Fan 2	Fan - medium speed
Fan 3	Fan - high speed
Filter	Factory link
Timer	Factory link
Door	Factory link

## 4.9 Factory Wiring - Ambient

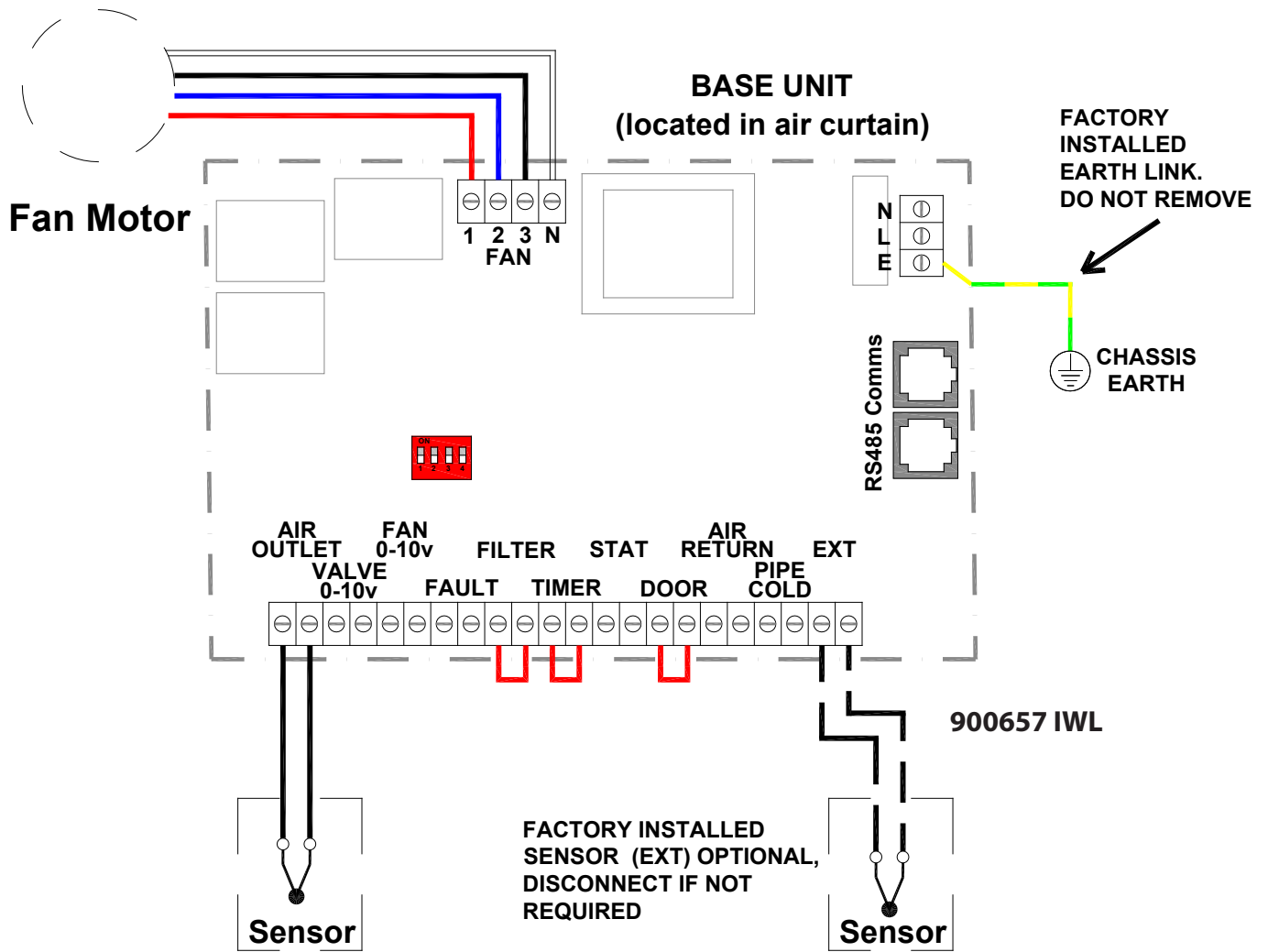

The fan output is connected to a 4 way connector marked "Fan 1,2,3 & N"

Pcb Terminal	Description
Fan 1	Fan - low speed
Fan 2	Fan - medium speed
Fan 3	Fan - high speed
Filter	Factory link
Timer	Factory link
Door	Factory link
Ext	Internal/external sensor (supplied)
Air outlet	Air outlet sensor

### 4.10 Factory Wiring - LPHW

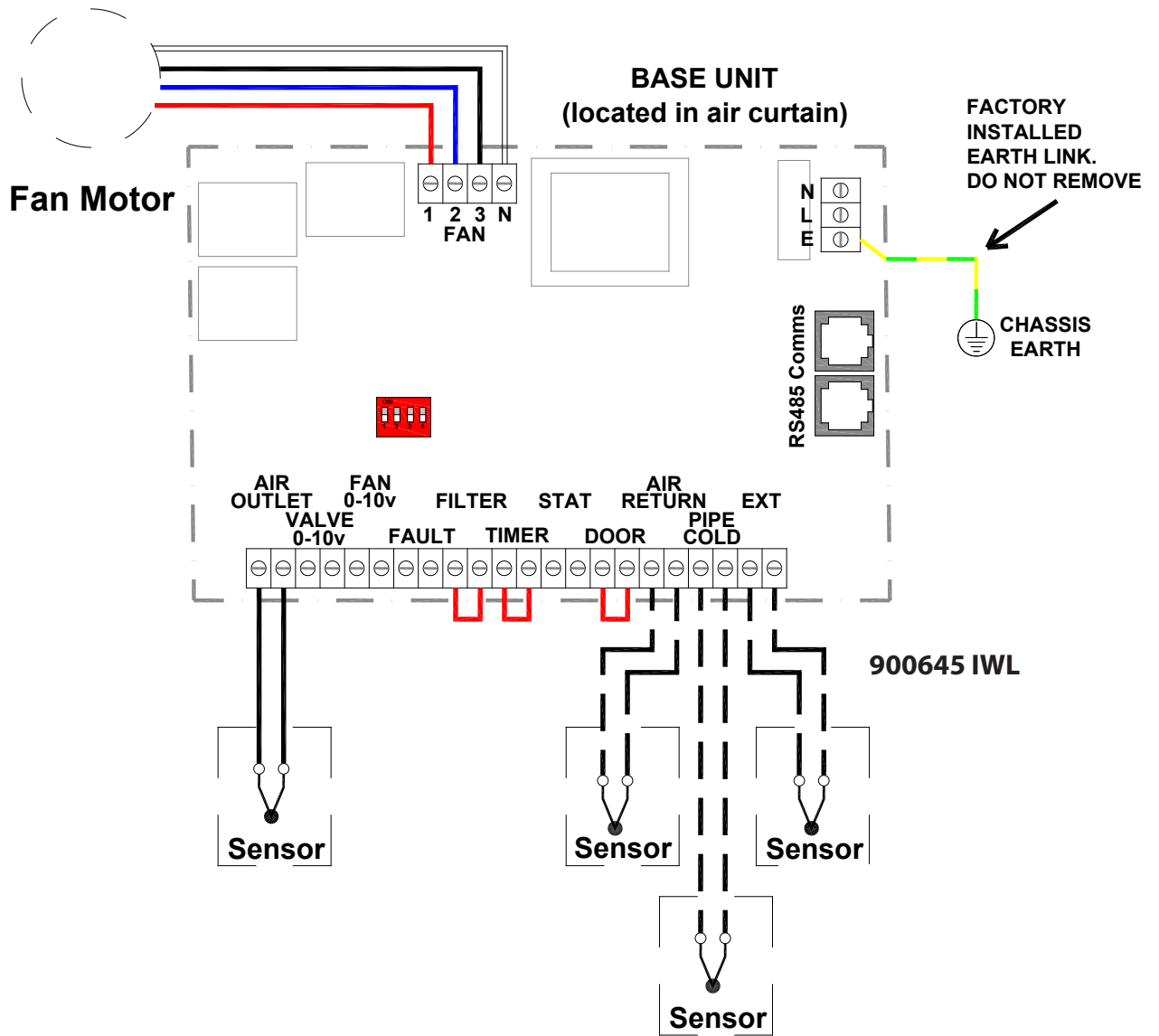

The fan output is connected to a 4 way connector marked "Fan 1,2,3 & N"

Pcb Terminal	Description
Fan 1	Fan - low speed
Fan 2	Fan - medium speed
Fan 3	Fan - high speed
Filter	Factory link
Timer	Factory link
Door	Factory link
Air return	Sensor
Pipe cold	Sensor
Ext	Option internal/external sensor(supplied)
Air outlet	Air outlet sensor

## 4.11 Network Wiring - Ambient/LPHW

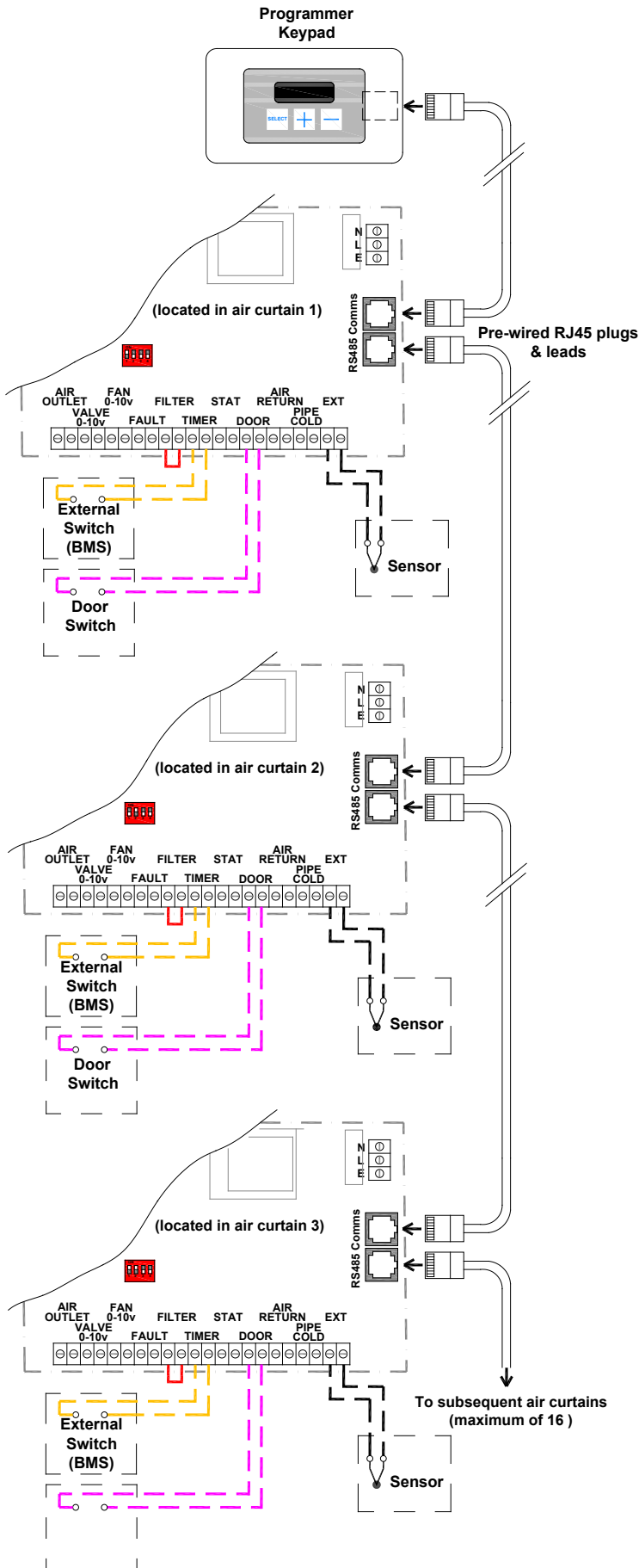

### Networking

This diagram refers only to the wiring of 2 or more networked air curtains. (maximum 16 air curtains per control panel). For mains wiring refer to section 4 of this manual 'installer wiring details'.

The program panel is connected to the base unit in the first air curtain via pre-wired cable fitted with RJ45 plugs.

Each subsequent air curtain is wired with the same type of cable.

**!** Max length 100m. (Total length of cable used between program panel and last air curtain in network).

It is recommended that this control cable is run separately within its own trunking if possible to avoid external interference.

**!** Note: All air curtains connected within the network system can be controlled under the user settings of the single keypad.

For more information on setup and control please refer to section 10 'User and Operating Instructions'.

## 4.12 Network Wiring - Standard controller

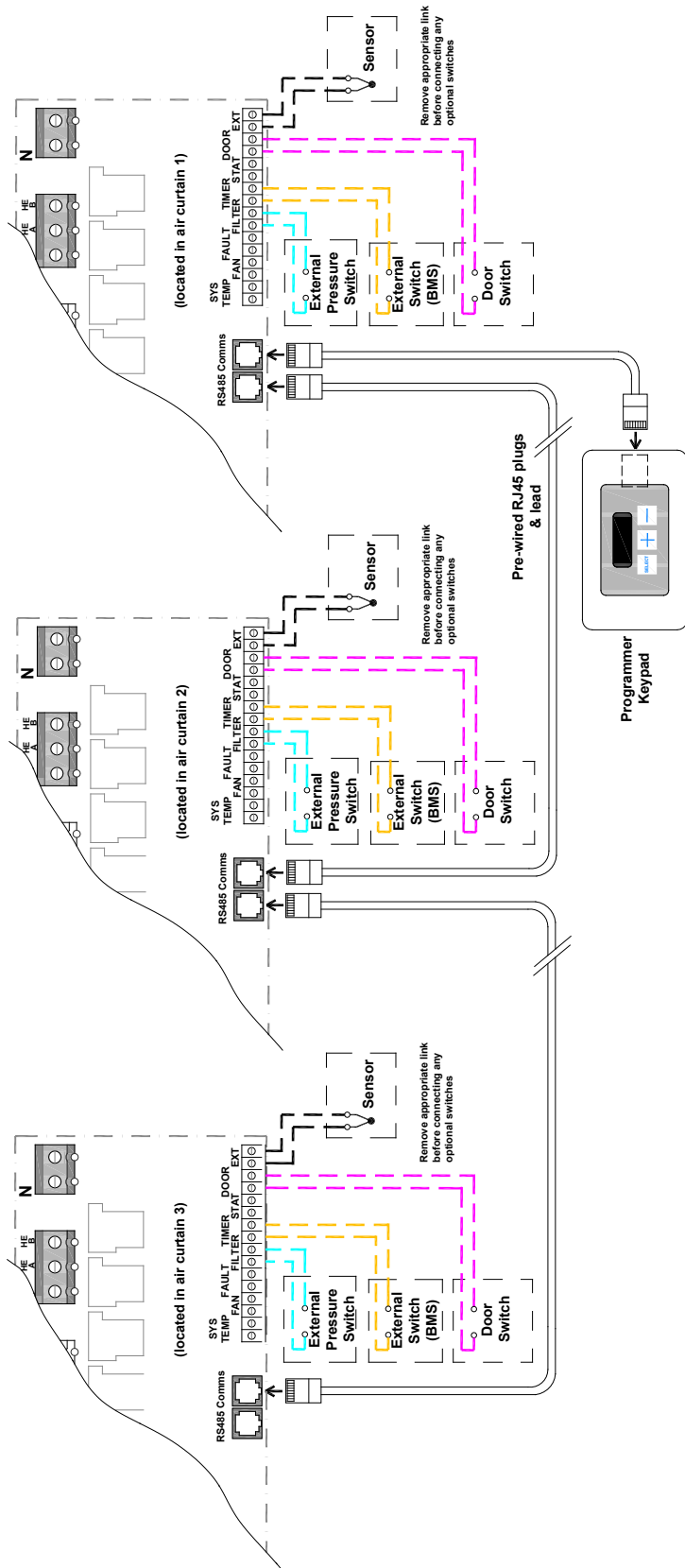

### Networking

This diagram refers only to the wiring of 2 or more networked air curtains. (maximum 16 air curtains per control panel). For mains wiring refer to section 4 of this manual 'installer wiring details'.

The program panel is connected to the base unit in the first air curtain via pre-wired lead fitted with RJ45 plugs.

Each subsequent air curtain is wired with the same type of lead.

**⚠ Max length 100m.** (Total length of cable used between program panel and last air curtain in network).

It is recommended that this control cable is run separately within its own trunking if possible to avoid external interference.

**!** *Note: All air curtains connected within the network system can be controlled under the user settings of the single keypad.*

For more information on setup and control please refer to section 10 'User and Operating Instructions'.

## 4.13 Installer wiring SmartElec3 control.

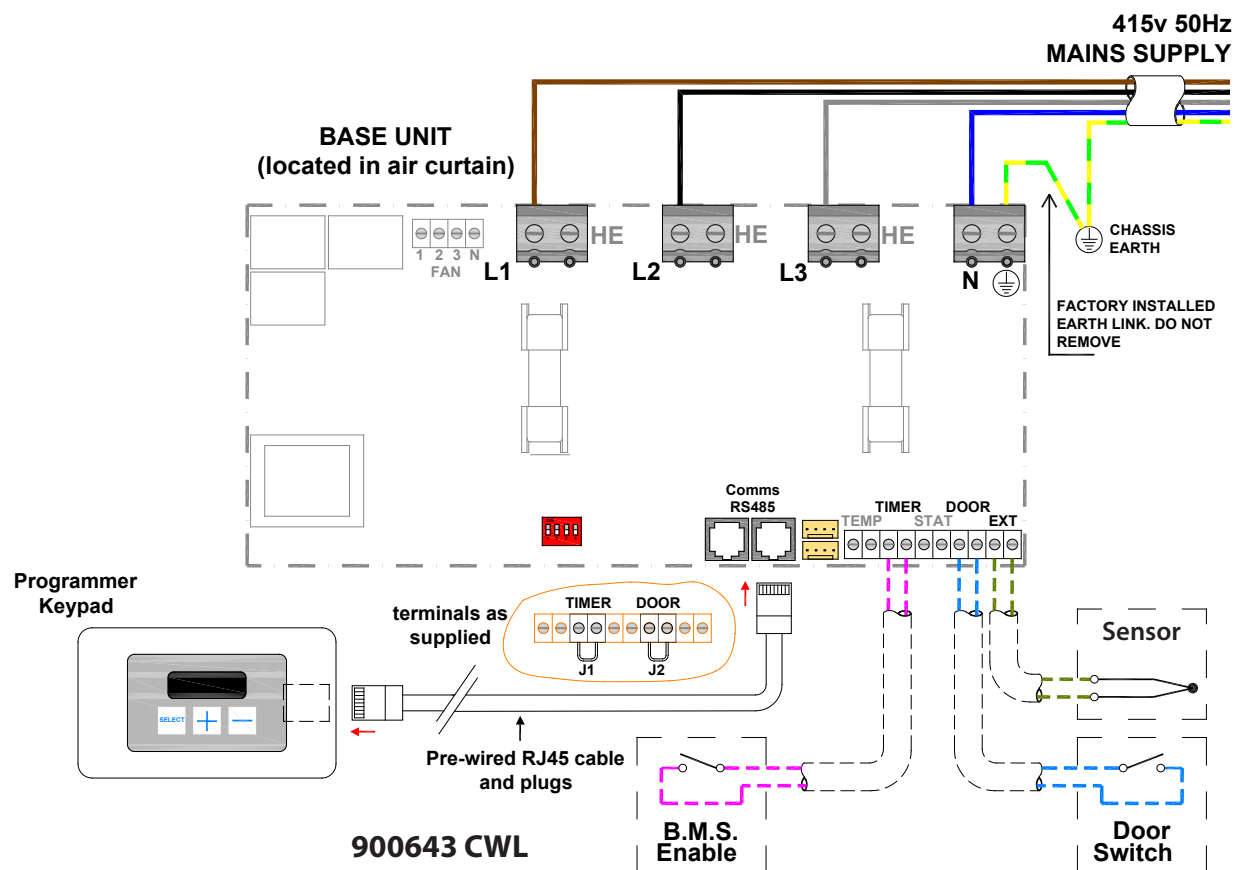

### Interconnecting wiring

The program panel is connected to the base unit via a pre-wired RJ45 cables as shown and supplied in 2, 10, 20, 30, 50 and 100m lengths.



It is recommended that this control cable is run separately within its own trunking where possible to avoid external interference.

### Optional wiring

**External switch** (ie BMS enable) to be volt free and wired via normally open contacts to terminal pair 'TIMER'. (Contacts closed to enable). Remove factory fitted jumper J1.

**Door switch** to be volt free and wired via normally closed contacts to terminal pair 'DOOR'. (Contacts open to enable door mode). Remove factory fitted jumper J2. refer section 11.2.6.1 - Door link settings.

**Internal/external sensor** to be wired to terminal pair 'EXT'. refer section 10.2.6.4 - External Temperature.

### Protection

There are two high speed fuses on the base unit to protect the switching thyristors for the heater. An external circuit breaker with the appropriate rating should be installed for the protection of the installation.

Terminal	Description	Cable
N	Neutral	10mm <sup>2</sup> max
L1	3 Phase supply	
L2	3 Phase supply	
L3	3 Phase supply	
E	Mains Earth	1.5mm <sup>2</sup> max
Timer	BMS pair (volt -free)	
Door	Door interlock pair, n.c. (volt free)	
Ext	Option internal/external sensor pair (supplied)	

## 4.14 Factory Wiring SmartElec3 Control.

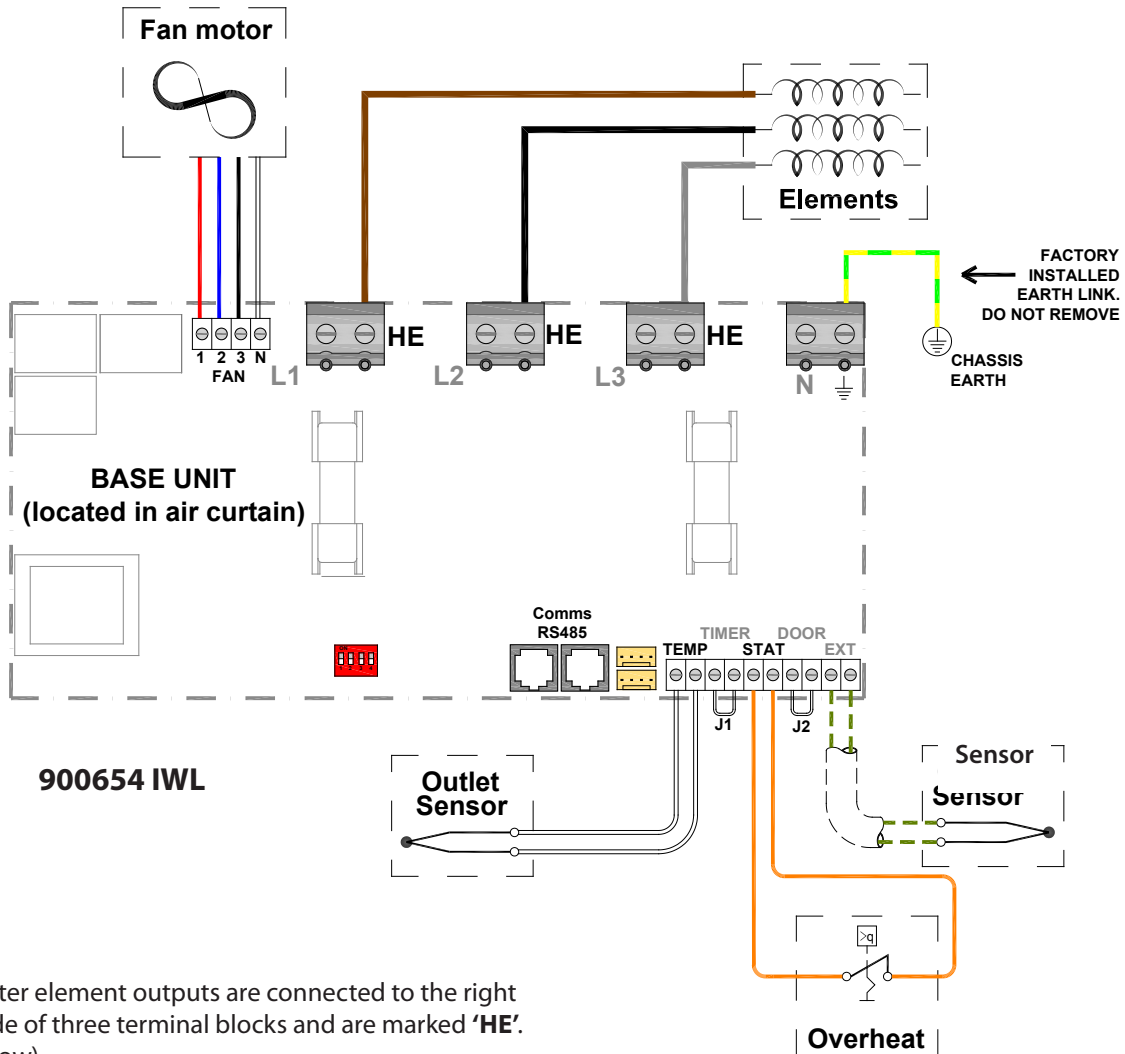

The heater element outputs are connected to the right hand side of three terminal blocks and are marked 'HE'. (See below).

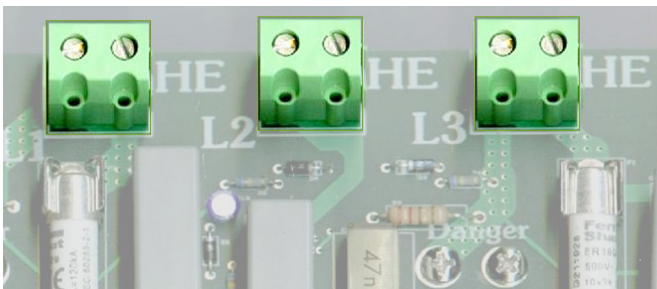

The fan output is connected to a 4 way terminal block marked 'N, 1, 2 and 3'.

The sensor input (air sensor) is connected to 2 terminals marked 'TEMP' on the base unit. The sensor is not polarity sensitive.

The external thermal trip (volt-free) is connected to 2 terminals marked 'STAT' on the base unit. The terminals are not polarity sensitive.

Terminal	Description	Cable
HE	Heating elements phase 1	10mm <sup>2</sup> max
HE	Heating elements phase 2	
HE	Heating elements phase 3	
N	Neutral to fan	1.5mm <sup>2</sup> max
Fan 1	Fan - low speed	
Fan 2	Fan - medium speed	
Fan 3	Fan - high speed	
Temp	Air sensor pair (non-polarised)	
Stat	Ext thermal trip pair, n.c. (volt-free)	
EXT	Option internal/external sensor (supplied)	
Comms	Keypad/network connectors	RJ45

#### 4.15 Network Wiring - SmartElec3 Control.

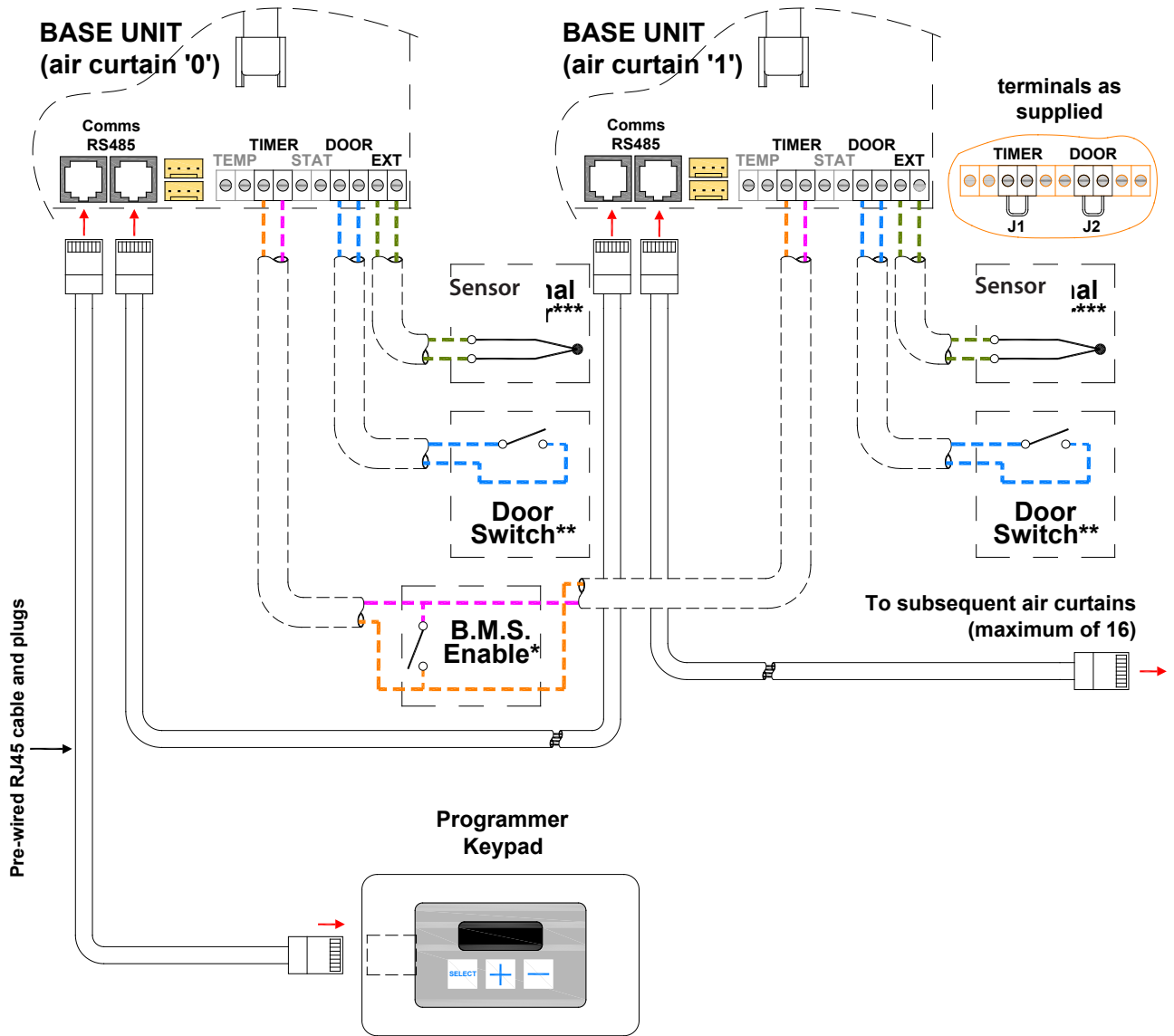

This diagram refers only to the wiring of 2 or more networked air curtains. (maximum 16 air curtains per control panel). For mains wiring refer to section 4 of this manual 'installer wiring details'.

The program panel is connected to the base unit in the air curtain via pre-wired RJ45 cable/plugs. These cables are available in 2, 10, 20, 30, 50 and 100m lengths. It is recommended that this control cable is run separately within its own trunking to avoid external interference.

**⚠ Max cable run in any network must not exceed 110m in total including program panel cable.**

**📢 Note: All air curtains connected within the network system will operate under the settings of the single keypad.**

Any air curtain within the network can be connected with and respond to the following optional circuits:

\* **External switch** (ie BMS enable) where required, to be volt free and wired in **PARALLEL** via normally open contacts to each terminal pair 'TIMER'. (Contacts closed to enable). Only air curtain(s) wired this way will respond to the enable signal. Remove factory fitted jumpers J1. (**NOTE: terminals are polarity sensitive**)

\*\* **Door switches** where required, to be volt free and wired to **INDIVIDUAL** base units via normally closed contacts to each terminal pair 'DOOR'. (Contacts open to enable door mode). Only air curtain(s) wired this way will respond to the door mode. Remove factory fitted jumper J2. refer section 11.2.6.1 - Door link settings.

\*\*\* **Internal/external sensors**, where required, to be wired to **INDIVIDUAL** base units to each terminal pair 'EXT'. Only air curtain(s) wired this way will respond to the sensor setting. If a sensor is fitted to more than one air curtain then the value is displayed as an average. refer section 10.2.6.4 - External temperature.

## 5. Installation Details.

### 5.1 Mounting

**A**irbloc units should be installed horizontally directly over the door opening. It is recommended that the air curtain is installed on the inside of the building, within the open room space against a wall or ceiling.

**!** Care must be taken to allow complete free air movement into the inlet grilles of the unit to ensure correct working operation of the air curtain. The discharge opening should be as close to the top of the door as possible and to cover the entire door width.

Units can be mounted adjacent to each other to cover the full door opening across wider entrances.

**!** These units are designed for surface mounting and should not be placed into a ceiling void, due to possible obstruction of airflow and difficulty in routine cleaning and maintenance.

### 5.2 Electrical Supply.

These units are suitable for connection to a 415 Volt, 50Hz 3 phase and neutral supply for Electrically heated 9-24kW models or 230/240 Volt 50 Hz single phase supply for Electrically heated 6kW, 9kW, Ambient and LPHW models.

Electrically heated models consume 6kW and 9kW at 230 volts and 9kW, 12kW, 18kW & 24kW at 415 Volts when switched to the full heat position depending on their model and capacity size .

The appliance shall be connected to the supply via an appropriate switched fused double pole isolator having a contact separation of greater than 3mm. Test for correct operation and refit the cover.

For connection to the mains supply it will be necessary to remove the outer cover from the unit. After removing the cover you will note the mains terminal block and it will be necessary to connect the mains supply and the lead from the remote switch box prior to refitting the cover. Wire in accordance to diagrams in section 4.1 to 4.5.

For optional SmartElec3 controller, wire as shown in diagrams 4.17 and 4.20.

**!** For safety reasons, a sound earth connection must always be made to the unit before it is put to use. The unit should be wired in accordance with IEE Regulations for the Electrical Equipment of Buildings.

### 5.3 Installation.

**!** It is the sole responsibility of the installer to ensure that the points of attachment to the building are sound. Verification with the consultant/architect or owner of the building is recommended to ensure that a sound, mechanically stable installation can be achieved.

All attachments must be capable of supporting the weight of the product detailed in Section 3.

#### Step 1

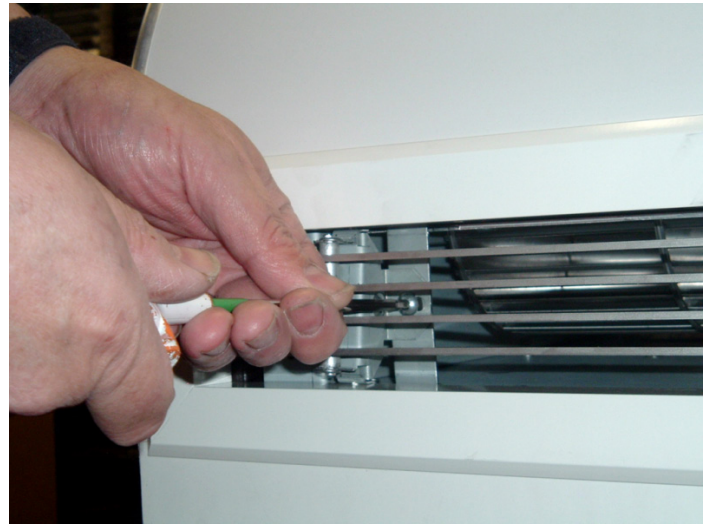

Remove all packaging. Remove decorative cover. Undo screws securing the outlet. (not Chassis version)

**!** Note All outer metal surfaces are covered by a protective plastic film, which must be removed before final fixing and operation of the unit.

#### Step 2



Carefully remove the air curtain front cover by removing four screws (not Chassis version)

### Step 3

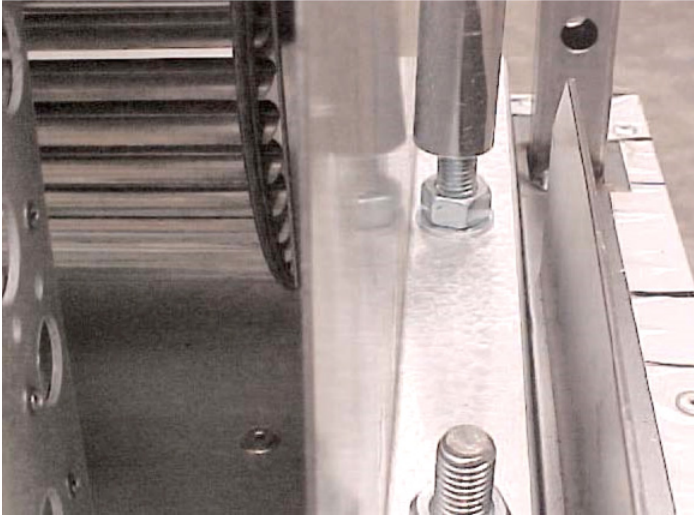

 It is recommended that the chassis is removed from the back box to avoid having to support the weight of the product during installation.

To separate the chassis from the back box undo and remove the nuts shown and lift the chassis away from the back box.

The product can be installed using either M12 drop rods or fastened direct to the wall using appropriate sized fixings suitable for the wall surface and the weight of the product.

### Step 4



To wall mount the product, position the back box against the wall at the desired mounting height and mark through the holes in the back box brackets to enable the wall to be drilled for the appropriate fixings.

### Step 5

Drill the wall then fix the backbox in position. Lift the chassis (using lifting gear if necessary) onto the studs on the back box brackets. Refit and tighten the nuts.

### Step 6

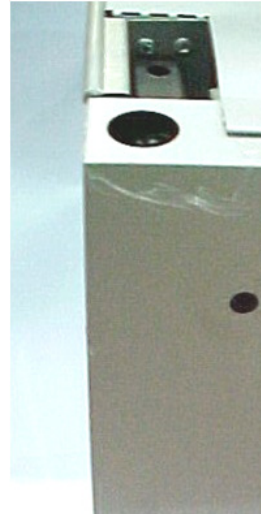

Holes are provided in the back box for the feed cable to enter the case. Choose the appropriate hole top rear to suit the installation.

Fit suitable cable gland for size of cable.

### Step 7

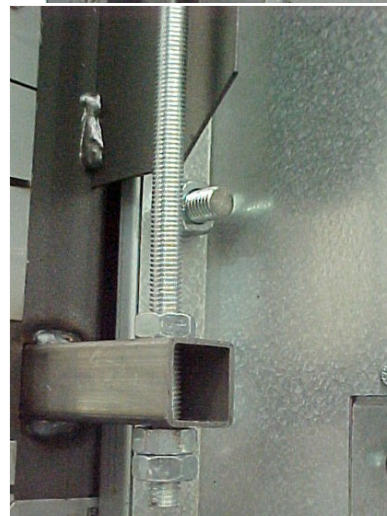

To install the product using M12 drop rods follow instructions from step 4. If the decorative tube is to be used, fit this over the drop rod, then pass the drop rod through the back box brackets.

## Step 8

Adjust the product to the required height and ensure that it is fitted level using a spirit level across the back box as required.

Tighten the lock nuts and re-assemble in reverse order. Adjust outlet to required angle to give desired performance, and tighten outlet screws.

## 5.4 Program keypad

The Electronic base unit is pre-installed inside the air curtain. All the external electrical connections except the keypad are via screw terminals onto this unit.

The program keypad can either be installed on a standard double surface box, or recessed using a double flush conduit box.



Fig. 3. Surface mount dimensions.

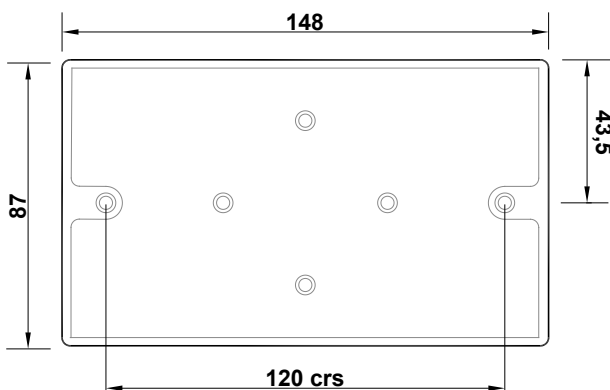

Alternatively, the program panel can be flush wall mounted with the addition of a suitable conduit box as shown in Fig 8.

 The distance between the base unit and the program panel can be up to 100m maximum.

Fig.4 Conduit box flush mounting



## 5.5 Option SmartElec3 Controller

The SmartElec3 base unit is pre-installed inside the air curtain. All the external electrical connections except the keypad are via screw terminals onto this base unit.

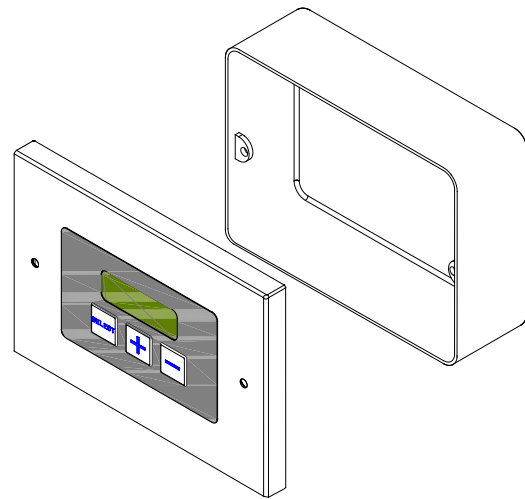
The SmartElec3 program panel is identical to the standard program panel and will auto detect a Smartcom base unit when plugged in.

## 5.6 Installation details - LPHW Only

Installation of the LPHW unit is as described earlier. Once situated, access to the heating coil and controller base unit is via removal of the case front.

The LPHW copper tubing connections are as shown in fig.11 below and are 15mm outside diameter. Ensure correct water seal fittings are used. We recommend the use of a suitable water mains isolation valve to ease any maintenance.

The unit is handed for right hand pipe connection.

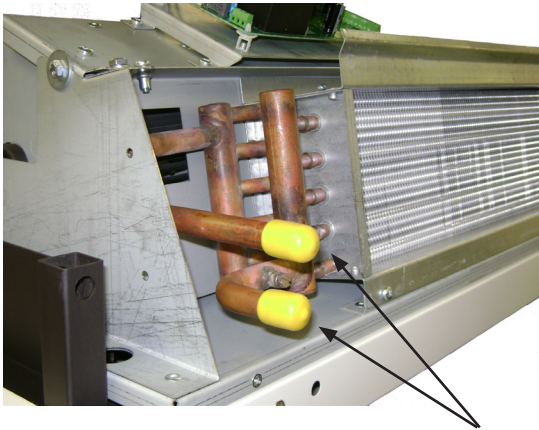



Fig. 11 LPHW Connections.

FLOW/RETURN

### 5.6.1 Three Port Valve

An optional 3 port valve (supplied by others) can be used on the flow and return pipes to divert the hot water from the unit when not in use.

 The valve must be fitted in accordance with the manufacturers instructions.

When used in conjunction with the standard programmer, the 3 port valve can be wired into the base unit to open the valve when heat is selected (see section 4.5). This valve must operate on 0-10v DC.

 Note: This option can not operate with a SmartElec unit.



## 5.7 Installation wiring

With the air curtain cover removed and chassis exposed, connect the electrical supply and program panel interconnecting wiring/factory supplied cables to the relevant terminals on the controller base unit.

Connect any interconnecting factory supplied cables to the programme panel.

Connect any optional wiring as required.

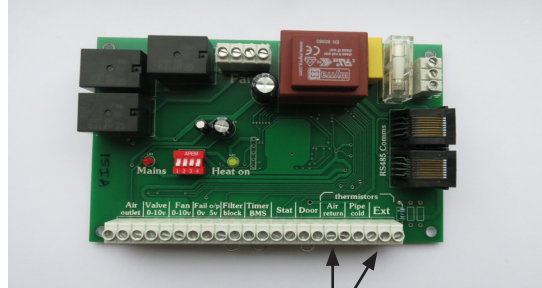

Customer wiring terminals.

For full details see wiring diagrams in section 4. Ensure the correct diagram is used based on the information from the air curtain data plate and optional manufactures information

 **WARNING:**  
**THIS AIR CURTAIN SHOULD NOT BE INSTALLED WHERE THERE IS A CORROSIVE ATMOSPHERE.**

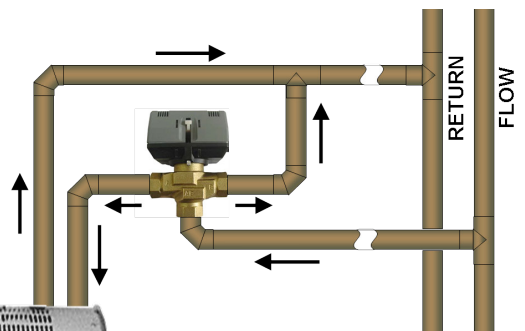



Fig. 5. Typical schematic of a 3 port valve system

## 6. Optional Fire Exit Luminaire.



### 6.1 General

All emergency lighting luminaires supplied are designed and manufactured to conform with relevant British Standard specifications.

 It is important that the user does not modify any luminaire or use them for a purpose, or in an environment for which the luminaires are not designed.

 Any modifications may render the luminaires unsafe and will invalidate the warranty and CE compliance of the product.

All luminaires unless otherwise stated are designed for direct connection to a standard mains supply as indicated on the luminaire wiring diagram. All switching etc. shall comply with BS 5266 part 1 and the latest IEE regulations. Luminaires shall NOT be connected to, or be controlled by an energy management system.

 Installation must only be carried out by a competent electrician and in accordance with the installation and commissioning instructions.

Installation must be carried out in accordance with:

- Regulations for Electrical Installation, published by the Institute of Electrical Engineers.
- Requirements of BS 5266 part 1.

Surge suppressers may be required at the point of connection to the supply wiring when installing luminaires to MICC.

### 6.2 Remote switching (Maintained)

This facility enables the luminaire to be switched off when the maintained light is not required.

This facility does not affect the operation of the unit in emergency mode should a mains failure occur. When the switched live is energised, the unit will operate in the maintained mode with the luminaire energised via the mains supply. When the live is de-energised, the luminaire will operate in the non-maintained mode. If this facility is not required, simply linking the switched and unswitched terminals together will cause the luminaire to operate in maintained/sustained mode at all times.

### 6.3 Commissioning/Testing

 The unit should be left on charge for a minimum of 24 hours before being tested for its rated duration. After connecting the mains supply check that:

- The green Led is illuminated. This indicates that the battery is being charged correctly.
- Once charged, removing the mains supply should turn on the luminaire.

Routine testing should be carried out in accordance with the instructions as indicated on the test record card. (Which is supplied with each product).

### 6.4 Specification

Input Voltage: 230-240V AC 50Hz 0.06A

Lumens output 120 (2 x 1W LED)

Battery Data: High temperature NiCd D cell

4 cell, 1.2V per cell (4.8v)

1.5 amp/hour rating

Power off duration 3hrs  
 Recharge time 24hrs  
 Weight 1.7kg  
 0-35°C operating temperature

 *Note: Lighting levels are only provided to allow checking of correct operation, and determination of correct lighting levels in an escape route can only be made with full photometric data.*

 **BEFORE OBTAINING ACCESS TO TERMINALS, ISOLATE ALL SUPPLY CIRCUITS.**

 This fitting must be electrically earthed.

Confirm the installation requirements by checking the data provided (especially the AC supply and mode of operation required). Installation must only be carried out by a competent person.

#### 6.4.1 Non maintained

A luminaire in which the lamp is lit only under emergency conditions.

#### 6.4.2 Maintained

A luminaire in which the lamp is lit either via a separate switched supply or under emergency conditions.

## 6.5 Installation

Access to the luminaire wiring connections is made by removing the two lens retaining screws then gently pulling the outer section from the rear tray. Run cable from main air curtain entry knockout through the 12mm access hole in the luminaire case. Connect the mains supplies to the terminal block provided inside the unit, (see connection diagram). Refer to remote switching instructions for further details. Refit lens and test unit for correct operation.

The battery connections are via faston connectors from the PCB to the battery pack. The battery pack should be marked with the date of installation/commissioning.

Refer to general, operating and test Instructions for further details.

 *Note: When the live is de-energised, the luminaire will operate in non-maintained mode. If this facility is not required, simply linking the switched and unswitched terminals together will cause the luminaire to operate in maintained mode at all times.*

## 6.6 Wiring Diagram

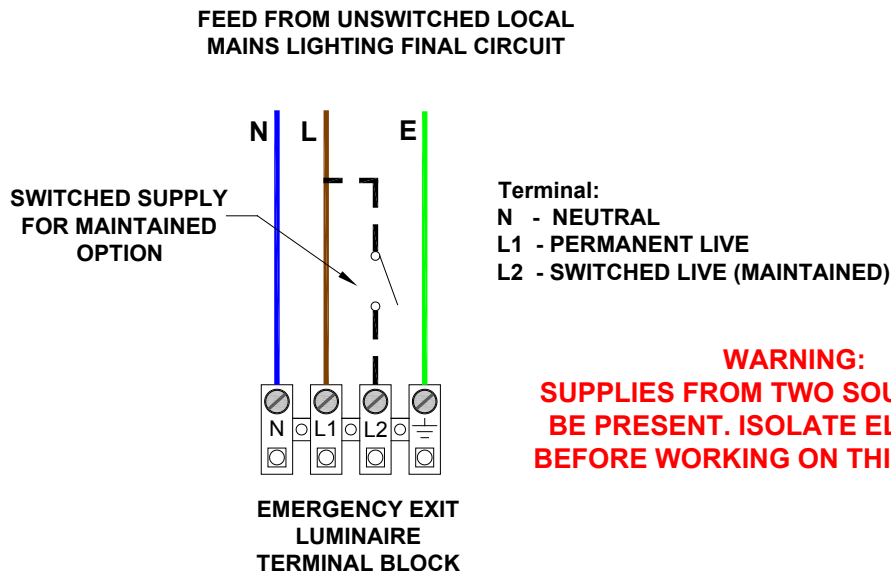

### AIRBLOC AC FIRE EXIT LUMINAIRE WIRING

## 7. Service & Maintenance.

**⚠ ALWAYS ENSURE THAT THE MAIN EXTERNAL ELECTRICITY SUPPLY IS SWITCHED OFF BEFORE COMMENCING ANY MAINTENANCE ON THIS HEATER**

**⚠** To obtain the best results from the heater, it is essential to avoid the accumulation of dust and dirt within the unit on the air inlet and discharge grilles. For this reason regular cleaning is necessary, paying particular attention to the removal of dirt build up on the rotor blades.

Cleaning of the fan is best carried out with a soft brush.

A single drop of light oil should be applied to the motor bearing from time to time.

The product should be serviced annually. Servicing should be undertaken by a competent person. The manufacturers offer a service facility, call 01384 489700.

### Step 1

Undo screws securing the grille.

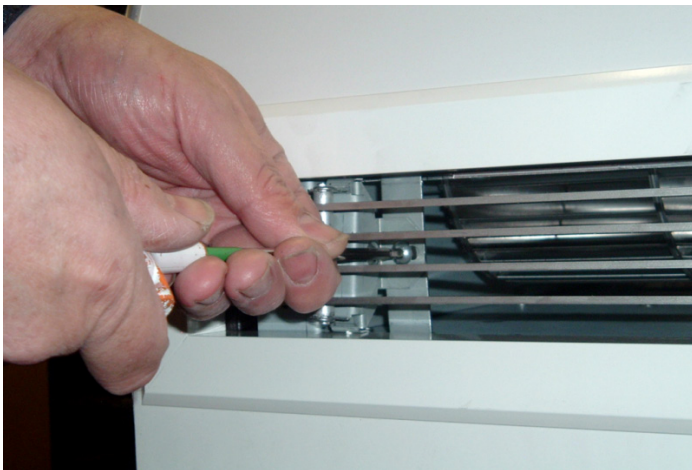

### Step 2

Adjust the grille by turning the screw inside with an allen key.

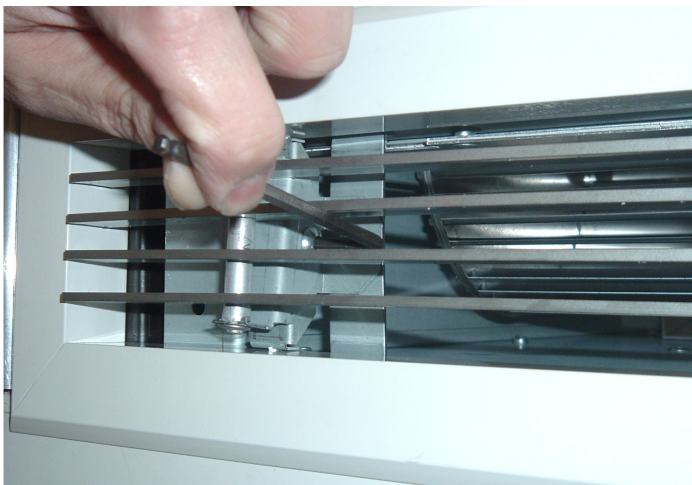

### Step 3

Remove 4 screws securing the top of the case and remove (not Chassis version)



### Step 4

Slacken two bolts on both ends.

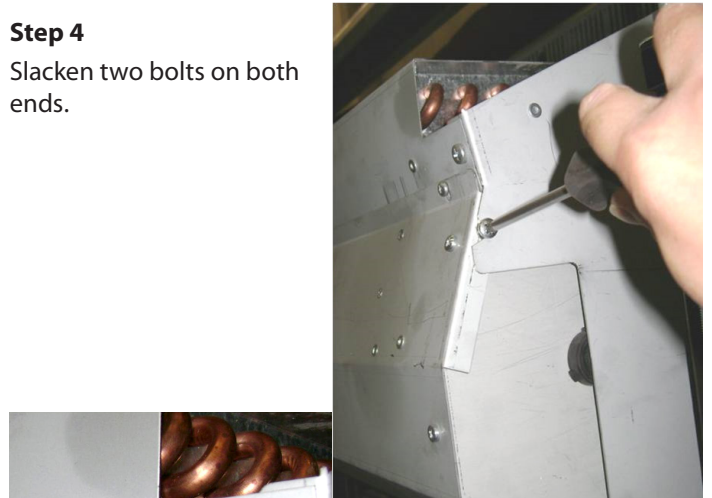

### Step 5

Remove three bolts securing the access plate.

### Step 6

Carefully hinge down the access plate.



*Note Take the weight as access plate swings down.*

### Step 7

With a soft brush clean away any dust from the motor and elements.





Check all connections and components for soundness or signs of deterioration and replace as necessary.

Re-assemble and test.

## 8. Spare Parts.

 Note Any spare part components that are not approved by AmbiRad could invalidate the approval of the appliance and validity of the warranty.



### 8.1 General

Item	Description	AC1000SE06/ AC1000SE09 AC1000HE12/ AC1000SW9/ AC1000HW12/ AC1000SA/ AC1000HA	AC1500SE6/ AC1500SE12 AC1500HE18/ AC1500SW12/ AC1500HW18/ AC1500SA/ AC1500HA	AC2000SE9/ AC2000SE18 AC2000HE24/ AC2000SW18/ AC2000HW24/ AC2000SA/ AC2000HA
	Motor	100535		
	Contactor (24kW only)	900078		
	Rotor Left Hand*	100539	100540	100541
	Rotor Right Hand*	100536	100537	100538
	Thermal Cut Out (where reqd)	900001		

\* Right hand & left hand when viewed from outside the building looking into the door opening.









### 8.2 Standard Controller

 Due to the nature of it's construction, it is not advisable to repair damaged electronic components on either the base unit or programmer (keypad)

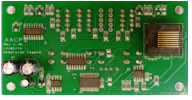
	Program Keypad	108221-RJ45
	Base Unit	STDELECBU45 (electric) LPHWBU45 (LPHW+ambient)
	Outside Air Sensor	SC-OS

### 8.3 SmartElec3 Controller

 Due to the nature of its construction, it is not advisable to repair damaged electronic components on either the SELEC3BU45 base unit or AC-ACRRP45 programmer

Item	Desc.	9/12/18kW models	24kW models	Item	Desc.	9/12/18kW models	24kW models
	Program Panel		108221-RJ45		Control Fuse		100535
	Panel P.C.B.		AC-ACRRP45		Outdoor Sensor		SC/OS
	Base Unit		SELEC3BU45		Data cable c/w plugs		2M RJ45-CABLE-2 10M RJ45-CABLE-10 20M RJ45-CABLE-20 30M RJ45-CABLE-30 50M RJ45-CABLE-50 100M RJ45-CABLE-100
	Heat Sensor		SELEC2HS				
	Fuse	900471	900472				

### 8.4 Heat Mediums

#### Electric Element

Item	Rating	6kW	9kW	12kW	18kW	24kW
	SE 1Pha	103713/103714	107819			
	length	1.0m/1.5m	2.0m			
	HE 3Pha		100840	100841	100842	
	length		1.0m	1.5m	2.0m	
	HE 3Pha			100526	100527	100528
	length			1.0m	1.5m	2.0m

#### LPHW coil

Item	Rating	9kW	12kW	18kW	24kW
	SE	101279	101280	101281	
	length	1.0m	1.5m	2.0	
	HE		100989	100990	100991
	length		1.0m	1.5m	2.0m

## 9. Fault Finding.

### 9.1 General

If the air curtain does not operate after running through the detail provided in Section 6, then a suitably competent service engineer should be called to identify the nature of the fault.



*Note The manufacturer operates a service function from the address provided in these instructions.*

All Air Curtains are fitted with fuse protection and motor thermal protection.

Other faults in relation to the element, motor and wiring should be identified using conventional fault finding techniques.

In the event that electrical components are replaced, please ensure that electrical safety checks in accordance with the regulations in force in the country of use are undertaken.

### 9.2 Electrically heated units only.

For the service engineer, please note that there is a thermal cut-out incorporated in the air curtain which needs to be manually reset. The cut-out is located near to the mains terminal block.

Re-setting the thermal cut-out may help to identify the nature of the fault however we do not recommend re-set without a thorough investigation into why the cut-out operated.

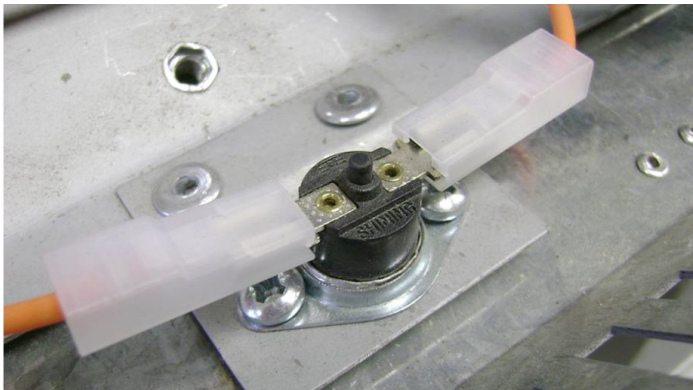
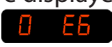

Fig. 13. Thermal Cut-out

### 9.3 Standard Controller.



For fault codes refer to SmartElec3 fault table on next page.



### 9.4 SmartElec3 Controllers.

The SmartElec3 control raises an alarm if any of its inputs are outside their normal working scope. Alarms are displayed on the program panel as a code with a prefix "E" . The first number represents the air curtain address. See chart over.

As the alarms are mutually exclusive, the first alarm code

displayed on the program panel will stay on until the fault has been cleared.

Apart from the communication failure alarm  which could be due to a broken connection of the data link and air curtain not found alarm,  which could be due to incorrect addressing, all other alarms will cause the base unit to switch off the heater output.

The SmartElec3 base unit is protected from any short circuit on the air sensor  or heat sink sensor  as the error will cause the temperature to rise and trigger over temperature alarm. 

There are five basic checks to perform should 'X--'  appear on the program panel display. These are as follows:

1: Continuity: Use a multimeter to check continuity between each end of all four cores at the plugs

2: Short circuit: Use a multimeter to check that there are no short circuits between any of the four cores.



3: Plugs: Check that the plugs are firmly seated in the circuit board sockets in both the program panel and on the base unit.

4: Addressing: (Network versions only). If two or more air curtains are networked, check that each base unit has a unique address as described in section 12.4

5: Network cables: Ensure that the total run of all cables in the network does not exceed 110m including the cable to the program panel.

If a panel has never before been run, it automatically starts in engineer's mode when first powered-up. To exit this mode, press and hold the  Button.

Alternatively, the engineer's mode automatically self-clears after approximately 10 minutes of non-activity on the switches.

The system can be reset by powering-up the panel whilst holding down both the  and  buttons.

The display shows the 'start' pattern but then goes blank.

Release the buttons where upon the display resumes and the system addressing commences, finding only those air curtains which are actually connected and working.

If **E n9** appears on the display, press and hold the **+** button for a few seconds then release. The display will then return to the normal mode.

### 9.4.1 SmartElec3 Fault Codes

# = Air curtain address

# \_\_, #E1, #E2, #E5 and #E6 codes also apply to **standard controller**.

Code	Description	Symptom	Possible Cause	Remedy
# __	Communications failure	No control on unit	Bad data cable connection Damaged cable	Check data cables and plugs Replace damaged cable
# E1	Air sensor failed	Fan operating, no heat	Air sensor cable disconnected Air sensor broken	Check cable Replace air sensor
# E2	Air sensor temp too high	Fan operating, no heat	High ambient air temperature Incorrect impeller rotation Motor failure	Check ventilation Check rotation of impeller Check motor, replace if necessary
# E3	Heatsink too hot	Fan operating, no heat	High ambient air temp/faulty base unit	Replace SmartElec base unit
# E4	Heatsink sensor failure	Fan operating, no heat	Heatsink sensor wiring disconnected/faulty Heatsink sensor faulty	Check wiring Replace SmartElec base unit
# E5	Ext. temp sensor failure	Unit runs but no external temperature control	External temperature sensor faulty	Repair faulty wiring Replace faulty sensor
# E6	Overheat stat open circuit	Fan operating, no heat	Overheat stat open circuit	Replace overheat thermostat

### 9.4.2 SmartElec3 base unit LED indicator location/function

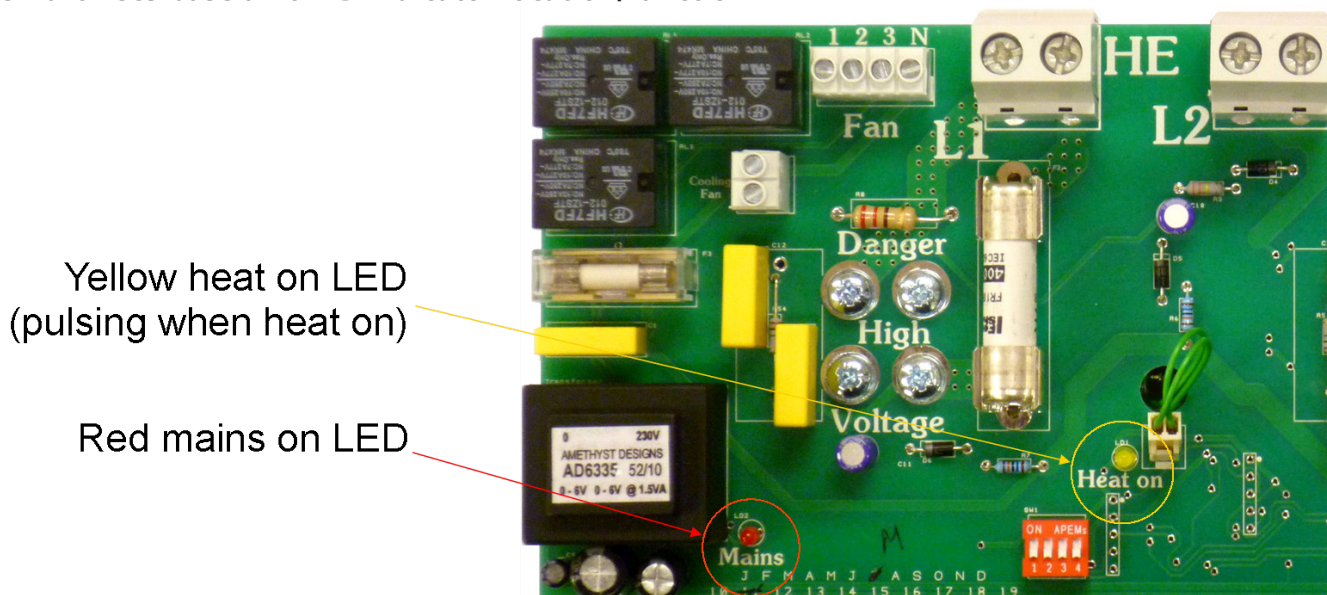

## 10. Parts Replacement.

### 10.1 Rotor and motor replacement.



**Warning**

Ensure electrical power is isolated from the product.

For access follow steps 1 - 4 as stated in Section 8

#### Step 1

Remove 3 screws securing fan bearing plate to access panel.

Carefully remove plate with bearing housing from rotor bearing.



#### Step 2

Slacken the grub screw securing rotors to the motor shaft, remove rotor.

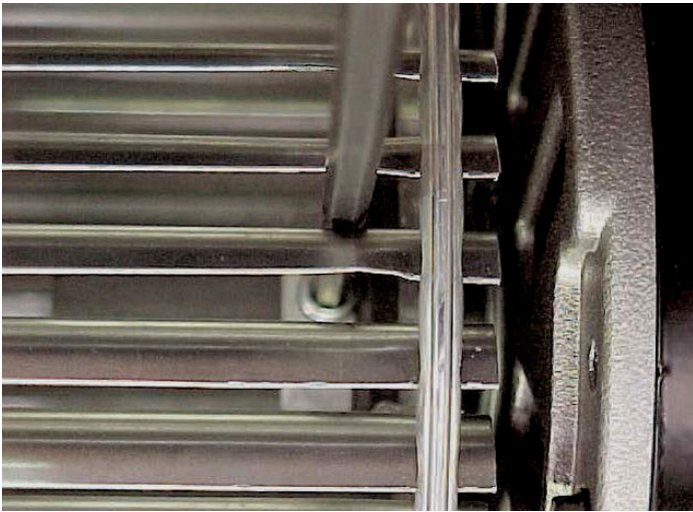

Repeat steps 1 - 2 for opposite rotor.

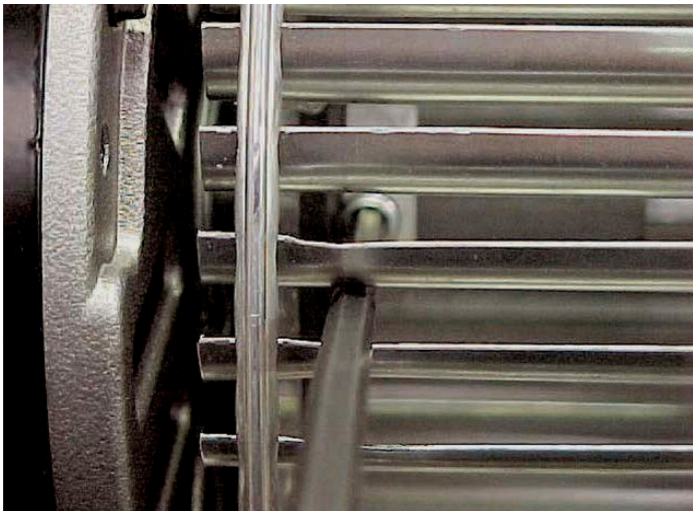

#### Step 4

Disconnect the wires from the motor to the mains terminal rail, including the earth which is bolted to the chassis. (Smart-Elec shown below)

Fan terminals (similar position on LPHW)

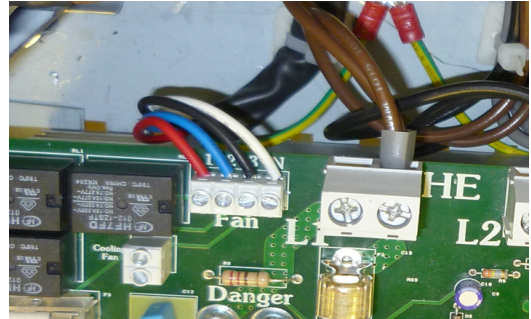
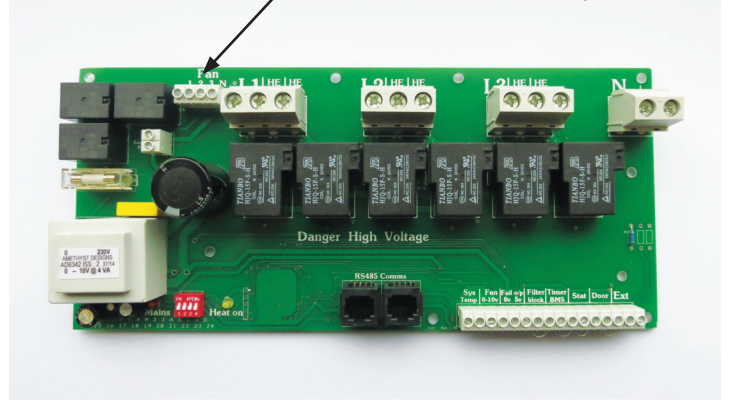

#### Step 5

Remove the bolts securing the motor to the chassis.

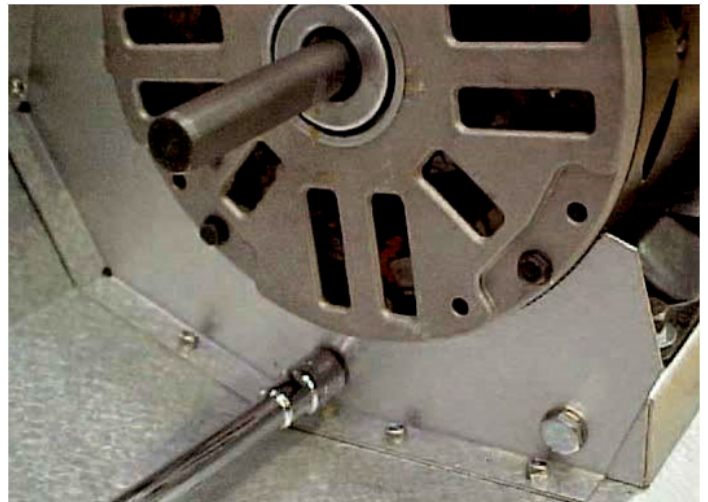

Replace motor as required.

#### Step 6

Refit in reverse of previous steps and test the performance of the product.

## 10.2 Element replacement.

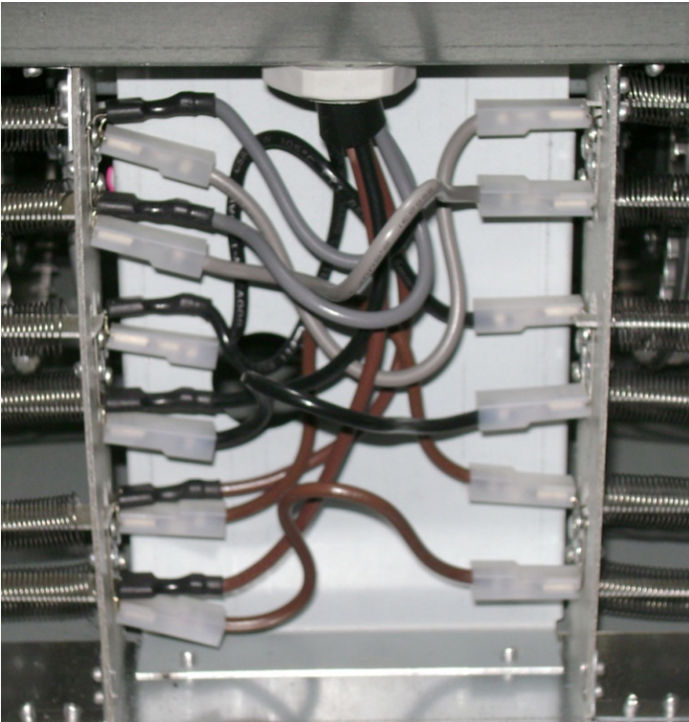

For access follow steps 1 - 4 as stated in Section 8

### Step 1.

Carefully remove connections to the elements, noting wiring configuration.

### Step 2.

Remove two bolts securing elements.

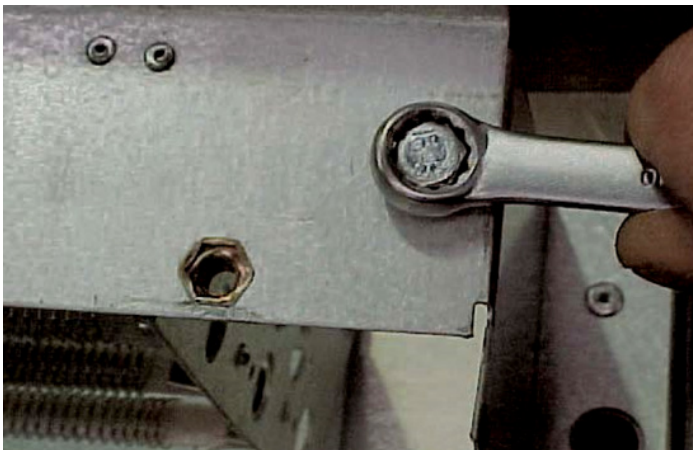

### Step 3.

Lift out element cartridge, replace as required.

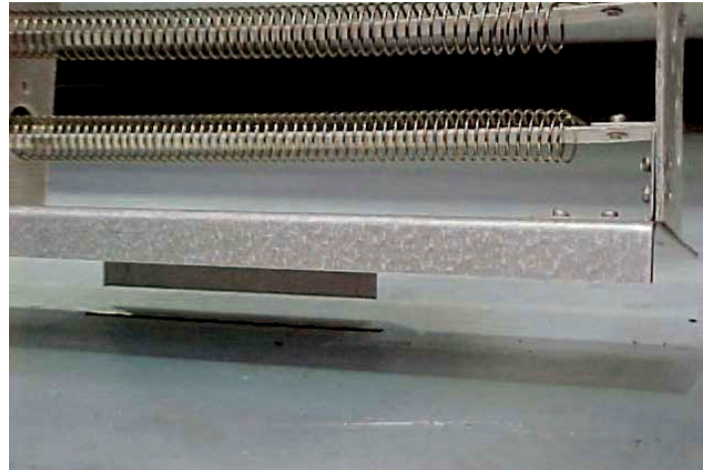

Refit in reverse order (including (motor refit on previous page)

Test performance of the product.

## 10.3 LPHW coil replacement.

For access follow steps 1 - 4 as stated in Section 8

### Step 1

Disconnect flow connections with appropriate tools.

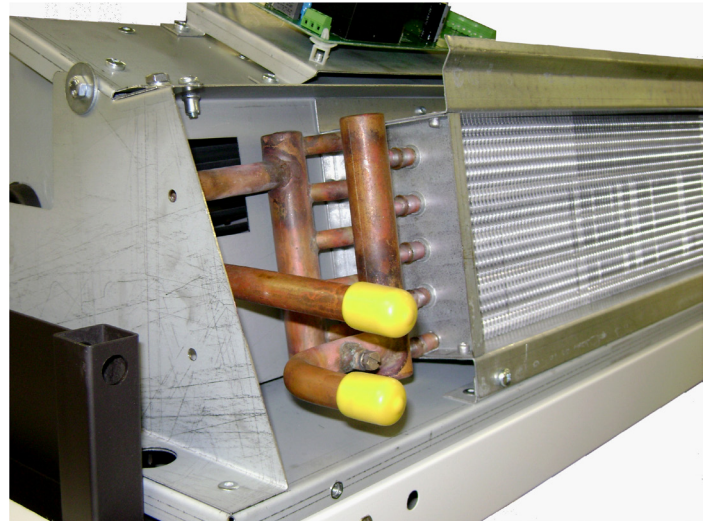

### Step 2.

Lift out element cartridge, replace as required.

Refit in reverse order (including (motor refit on previous page)

Test performance of the product.

# 11. User Instructions.

## 11.1 Standard Keypad



'1' denotes the AIR CURTAIN ADDRESS, and '27' the current outlet temperature.

If the display is set to 'H1' (half heat) then the display unit will show:



The 'dot' after the air curtain number denotes heat setting 1.

If the display is set to 'H2' (full heat) then the display unit will show:



The 'dot' after the temperature number denotes heat setting 2.

If an external temperature sensor is fitted then the display will also show:



The small 'zero' shows a sensor detected and it's current temperature reading.

### 11.1.3 Standard Settings

Press the **SELECT** button. This will cause the display to brighten and display air curtain number and it's fan speed eg.



Press the **+** or **-** buttons to increase/decrease the desired setting between F0, 1, 2, or 3.

Pressing the **SELECT** button again will display the air curtain number and it's heat setting eg.



Press the **+** or **-** buttons to increase/decrease the desired setting between H0, 1, or 2.

Pressing the **SELECT** button again will loop back to start if only one air curtain is connected to the display unit. If there is more than one connected the display unit will then show the settings for the next air curtain in the network and so on.

### 11.1.4 Engineers Settings

To turn on the engineers settings press and hold the **+** button until the display goes blank then press the **SELECT** button. The display unit will now display 'Eng' briefly.

### 11.1.1 Keypad Buttons



The **SELECT** button will allow you to navigate.

The **+** button will allow you to increase the setting.

The **-** button will allow you to decrease the setting.

### 11.1.2 Operation

On first power up, the display will show and have the following default settings:



- F.0 (no fan)
- H.0 (no heat)
- 16 (°C. Heat set point)

If no air curtains are detected the display will show:



**Note:** Subsequent power ups will retain any entered settings in the display internal memory.

In normal operation the display will show for example:

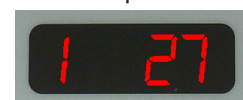

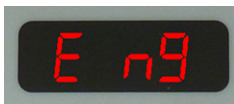

This will disappear after a period of 10 minutes of inactivity on the keypad.

On pressing the **SELECT** button the display unit now works in the same way as standard for the fan and heat settings, but then an adjustable control temperature setting appears (if external sensor fitted).



*This control works by reading the temperature at the sensor and comparing it to the set point. The temperature is then controlled by automatically switching the controller outputs between H0, H1, and H2, thus maintaining reasonable heat control.*

Pressing the **SELECT** button again advances to the door link settings.

### 11.1.4.1 Door Link Settings

Two settings are available for use when the door link circuit terminals are open circuit (PCB link removed). The first of these is displayed as:



'1' is the air curtain address and 'd2' denotes fan speed 2.

Press the **+** or **-** buttons to increase/decrease the desired setting between d0, 1, 2, or 3.

The second is displayed as:



'1' is the air curtain address and 't1' denotes heat setting 1.

Press the **+** or **-** buttons to increase/decrease the desired setting between t0, 1 or 2.

Pressing the **SELECT** button again advances to the link group interlock settings.

### 11.1.4.2 Link-Group Interlock

If there is more than one air curtain connected to the display then there are two sets of interlocks available to enable a single air curtain in a group to be the 'master' controller based on links used.



'1' is the air curtain address and 'C0' is the default setting (no interlock set)

Press the **+** or **-** buttons to increase/decrease the desired setting between C0, or 1-7 (see table below).

If the air curtain is set to eg.:



This denotes that air curtain '1' is set to be the master for door and BMS interlocks. If interrogated all other air curtains will then display eg.



This denotes a unit that is not the master.

#### 'C' interlocks setting

setting	Effect
1	Timer/BMS interlock
2	Door interlock
4	Stat interlock

#### 'L' interlocks setting

setting	Effect
1	Not used
2	Not used
4	Blocked filter interlock

To set more than one interlock, add the appropriate numbers together, eg. 'C3' above works on timer and door interlocks.



If a controller is not the master, all three interlock links must be in place.

### 11.1.4.3 All Controllers

This setting can be accessed from the engineers settings whilst the external temperature indication is showing (see previous page). This is displayed as:





This allows a single group of settings to be copied to all controllers in a network. Individual settings can still be used at a later date if required.

### Quick Options



#### 1. Immediate turn off:

Press and hold the **-** button for two seconds, the display will go blank then the air curtain(s) will turn off.

## 2. Re-scan/Engineers mode:

Press and hold the  button for two seconds, the display will go blank, then press . The display will show the controller type in the first digit and the number of air curtains in the fourth digit. Release both buttons and then press any button to continue, the panel is now in Engineers mode.

## 3. Turn on Engineers mode:

Press and hold the  button for two seconds, the display will go blank, then press  the display will show 'Eng', Release both buttons.

## 4. Turn off Engineers mode:

Press and hold the  button for two seconds, the display will go blank, then release.

**5. Air curtain addressing:** See section 10.2.8

## 11.2 LPHW/Ambient Controller

### 11.2.1 Keypad Buttons



The  button will allow you to navigate.

The  button will allow you to increase the setting.

The  button will allow you to decrease the setting.

### 11.2.2 Operation

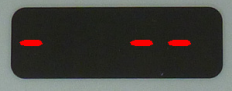
On first power up, the display will show  and have the following default settings:

- F. 0 (no fan)
- H. 0 (no heat)
- 16 (°C. Heat set point)

If no air curtains are detected the display will show:



*Note: Subsequent power ups will retain any entered settings in the display internal memory.*

In normal operation the display will show for example:



'1' denotes the air curtain address, and '27' the current outlet temperature.

If the display is delivering power then the display will show:



If an external temperature sensor is fitted then the display will also show:

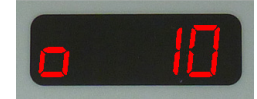

### 11.2.3 Standard Settings

Press the  button. This will cause the display to brighten and display air curtain number and it's set point temperature eg:





Pressing the  button again will show the fan settings eg:



Pressing the  button again will show the heat settings eg:





### 11.2.4 Engineers Settings

To turn on the engineers settings press and hold the  button until the display goes blank, then press the  button. The display unit will now display 'Eng' briefly.



This will disappear after a period of 10 minutes of inactivity on the keypad.

On pressing the  button again the display unit now works in the same way as standard for the fan and heat settings. The next press of  will advance to the 'door link' settings if only one air curtain is connected, or 'link group interlocks' if more than one air curtain is connected.

#### 11.2.4.1 Door Link Settings

Two settings are available for use when the door link circuit terminals are open circuit (PCB link removed). The first of these

is displayed as:



'1' is the air curtain address and 'd2' denotes fan speed 2.

Press the **+** or **-** buttons to increase/decrease the desired setting between d0, 1, 2, or 3.

The second is displayed as:



'1' is the air curtain address and 't1' denotes heat setting 1.

Press the **+** or **-** buttons to increase/decrease the desired setting between t0, 1, 2, 3 etc. where 0 is heat off

- 1 is 5°C
- 2 is 10°C
- 3 is 15°C

Pressing the **SELECT** button again advances to the link group interlock settings.

### 11.2.4.2 Link-Group Interlock

If there is more than one air curtain connected to the display then there are two sets of interlocks available to enable a single air curtain in a group to be the 'master' controller based on links used.



'1' is the air curtain address and 'C0' is the default setting (no interlock set)

Press the **+** or **-** buttons to increase/decrease the desired setting between C0, or 1-7 (see table below).

If the air curtain is set to eg.:



This denotes that air curtain '1' is set to be the master for door and BMS interlocks. If interrogated all other air curtains will then display eg.



This denotes a unit that is not the master.

To set more than one interlock, add the appropriate numbers together, eg. 'C3' above works on timer and door interlocks.

 If a controller is not the master, all three interlock links must be in place.

### 11.2.4.3 All controllers

'C' interlocks setting	Effect
1	Timer/BMS interlock
2	Door interlock
4	Stat interlock
'L' interlocks setting	Effect
1	Not used
2	Not used
4	Blocked filter interlock

This setting can be accessed from the engineers settings whilst the external temperature indication is showing (see previous page). This is displayed as:



This allows a single group of settings to be copied to all controllers in a network. Individual settings can still be used at a later date if required.

### 11.2.4.4 External Temperature

Display will show eg:



This will only be displayed if there is an external sensor fitted, and shows the external sensor temperature set point. Once set the air curtain will turn off when it reaches the set point. The temperature then has to drop 3°C before the air curtain turns back on again.

### 11.2.4.5 External Temperature Offset

Display will show eg:



If the outside temperature falls to zero°C, this setting shows the temperature offset above zero. This will temporarily raise the temperature setting 6°C above the actual set point. Possible settings are 0-9 where 0 is off if this function is not required.

### 11.2.4.6 Temperature Limits

The next two displays eg:



These show the permissible upper and lower limits for setting the external temperature sensor set point. This is useful for allowing the end user limited control over this setting. The maximum (default 35°C) may be set anywhere between the current minimum and 50°C, and the minimum (default 16°C) may be set anywhere between 3°C and the current maximum.

### 11.2.4.7 Air Return and Pipe Cold Sensors

The readings from these sensors is not shown on the display, and unless both are connected there is no effect on the heating control. When both sensors are connected they operate as follows: When the heating is first turned on the temperature readings from the sensors should be close together, two minutes later there should be a difference of at least 2°C. If there is no difference then the controller assumes that there is no flow then turns the heating off.

### Quick Settings

These are identical to the quick settings for the standard controller so please refer to that section of the manual on page 53.

## 11.3 Option SmartElec3 Controller

### 11.3.1 Keypad buttons



The buttons have the following functions:

 Press the select button to allow navigation.

 Press the + button to increase a setting.

 Press the - button to decrease a setting.

### 11.3.2 Operation

#### 11.3.2.1 Normal mode displays

 First power up

 No air curtains found

 Curtain address and temperature set point

#### 11.3.2.2 Normal Operation

During normal operation mode the display is dimmed.

Pressing the  button, will put the panel into active mode. If

During normal operation the unit will display for example:

 where '0' is the curtain address, and '25' the temperature measured for the unit.

 *Where multiple air curtains exist in a network, the display scrolls through each unit in turn, changing approximately once every second.*

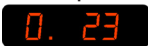
If the air curtain is in operation and under heat demand, a 'decimal point'  is shown after the air curtain address.

### Quick Options

These are identical to the quick settings for the standard controller so please refer to that section of the manual.



### 11.3.3 OFF mode.

During normal operation, press and hold the  button for approximately two seconds. The display blanks until you release the button. The heating and fans are now turned off. Releasing the button in less than this time and the action has no effect.





 *Where multiple air curtains exist in a network, this action turns off all air curtains.*

### 11.3.4 Settings Mode

#### 11.3.4.1 Activate settings display

To enter the Settings mode press the  button. This will illuminate the screen. Press the  button till the desired setting is shown.

By pressing the  button it will also advance to the next setting.

 Note: If a setting has been altered by using the  or  buttons, it must be confirmed by pressing the  button.

#### 11.3.4.2 Settings displays

Press the  button to advance through the settings. The displays will scroll as follows:

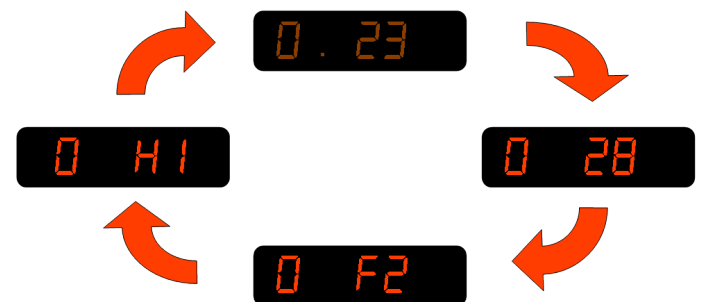

Where multiple air curtains exist in a network and controlled from a single keypad, these will be detected and displayed in turn, for example:



Any air curtain in the network can be accessed by pressing the  button when it's address appears on the display. The settings can then be accessed as previously described.

## 11.3.5 Set-up configurations

### 11.3.5.1 Set fan speed

Once the display becomes illuminated press the  button once. Display shows the fan speed.

Press  to increase fan speed.

Press  to decrease fan speed.

Three speeds and an 'off' setting are available:

 Speed 1     Speed 2

 Speed 3     Fan 'off'

### 11.3.5.2 Set heat

Press the  button again Display shows the heat setting.

Press  to set heat 'on'.

Press  to set heat 'off'.

If no button pressed for 2 seconds, display will revert to normal user. e.g. 

### 11.3.5.3 Set temperature

Press the  button once to allow changes to be made.

Press  to increase temperature set point. (max 35°C)

Press  to decrease temperature set point. (min 16°C)

Display shows for example: 

### 11.3.5.4 Networked air curtains

Where multiple air curtains exist in a network and controlled from a single keypad, these will be detected and displayed in turn, for example:









Any air curtain in the network can be accessed by pressing  when it's address appears on the display.

The settings can then be changed as previously described.

## 11.3.6 Engineers settings



Other options are available in engineer's mode.

To access the engineers mode either: press and hold the  button for a few seconds until the display goes blank, then press  briefly. The display will show 

or

Power-up the system with the  and  buttons pressed and release when the display goes blank the display will show



As in normal mode, Engineers set-up mode is started by pressing the  button whereupon the display will illuminate. Advance through the normal modes settings of temperature, fan and heat by pressing the  button.



Pressing the  button again advances to further options to allow other settings of the system. The engineers set-up options listed herewith depend various factors e.g. optional door switch, multiple air curtains etc.

 *Notes: If a panel has never before been run, it automatically starts in engineer's mode when first powered-up.*

 *Engineer's mode automatically self-clears after approximately 10 minutes of non-activity on the buttons.*

### 11.3.6.1: Door link settings:

This provides an alternative fan speed and heat setting which is activated only when the door link is open circuit.

The fan speed is accessed by pressing the  button until the display shows:  Use the  and  buttons to change the setting.

 Fan OFF



 Fan speed 1

 Fan speed 2

 Fan speed 3

The temperature setting when the door link is open circuit is accessed by pressing the  button until the display shows:



Use the  and  buttons to alter the temperature value.

 Heat OFF

 5°C

0 62 10°C

0 63 15°C

0 64 20°C

0 65 25°C

0 66 30°C

0 67 35°C

### 11.3.6.2 Link-group interlock

If there is more than one air curtain, a group interlock option may be set. This provides an alternative fan speed and heat setting when activated by certain external connections on individual air curtains.

This function is accessed by pressing the **SELECT** button until the display shows **0 00** (where '0' is the air curtain address to be used as a master unit for interlocks.)

See table to follow for possible settings.

0 d0 Default setting

0 d1 or 0 d1 Master setting range

0 d2 Other air curtains

See table below for possible settings.

Master setting	Function
1	Timer/BMS interlock
2	Door interlock
3	Timer/BMS/door interlock
4	Stat interlock
5	Timer/BMS/stat interlock
6	Stat/door interlock
7	Timer/BMS/stat/door interlock

### 11.3.6.3 All air curtains

This function is accessed by pressing the **SELECT** button until the display shows **≡ 35**

Using this setting all air curtains in a network respond to the same settings. Settings for individual air curtains can still be changed if required.

### 11.3.6.4 External temperature

This is only displayed if the factory supplied optional external temperature sensor is connected to the air curtain.

This function is accessed by pressing the **SELECT** button until the display shows: **0 25**

Use the **+** and **-** buttons to change to the desired temperature setting.

If the external temperature is equal to the set temperature, all air curtains are turned off. The temperature must then drop to 3°C below the set temperature before the air curtains are turned back on.

**!** Note: for multiple air curtains - more than one can have an external sensor connected. When this is the case the sensor values are displayed as an average. (If one external sensor goes faulty, the average is worked out from the remaining working ones).

### 11.3.6.5 External temperature offset

This function is accessed by pressing the **SELECT** button until the display shows: **004**

This setting allows the temperature setpoint to be automatically increased as the external temperature falls to, or below, zero. For instance, a setting of 4 means a +4°C offset at 0°C. The maximum offset is 9°C. If this feature is not required the setting should be: **000**

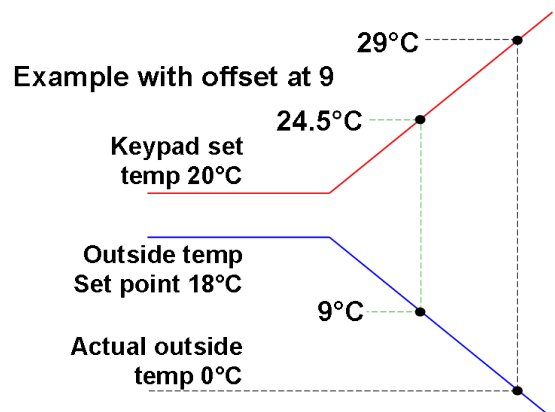

**!** Note: When more than one air curtain is used, this feature



will only work under the 'all controllers' setting.

### 11.3.6.6 Temperature limits

This function is accessed by pressing the  button until the display shows:

 and  respectively



i.e. maximum and minimum set limits for set temperature.

Use the  and  buttons to change to the desired limit temperature settings.



The maximum (default 35°C) may be set anywhere between the current minimum and 50°C, and the minimum, (default 16°C) may be set anywhere between 3°C and the current maximum.

To exit the engineers mode press and hold the  button for a few seconds.

### 11.3.7 Power-up Manual Reset

The system can be reset by powering-up the panel whilst holding down the  and  buttons. The display shows the 'start' pattern but then goes blank.

Release the buttons where upon the display resumes and the system addressing commences, finding only those air curtains which are actually connected and working.

If  appears on the display, press and hold the  button for a few seconds then release. The display will then return to the normal mode.

### 11.3.8 Air curtain addressing (standard and SmartElec)

All air curtains work on an address to communicate with the keypad and are supplied with a default address of '0'.

Where multiple air curtains exist in a network they must be re-addressed using a unique address (0-9/A-F). This is achieved using a 4 way bitswitch mounted on the base unit PCB (see photo on next page).

The keypad will check all addresses on first power up and this is displayed as the first digit on the display (in a network set up, all addressees will be viewed in rotation).

 *Note: If any address is altered after initial power up or an air curtain removed after initial installation, the keypad will also retain the original address although unable to respond.*

To remove this unwanted address(s) follow the details in 11.3.7

### Power-up Manual Reset.

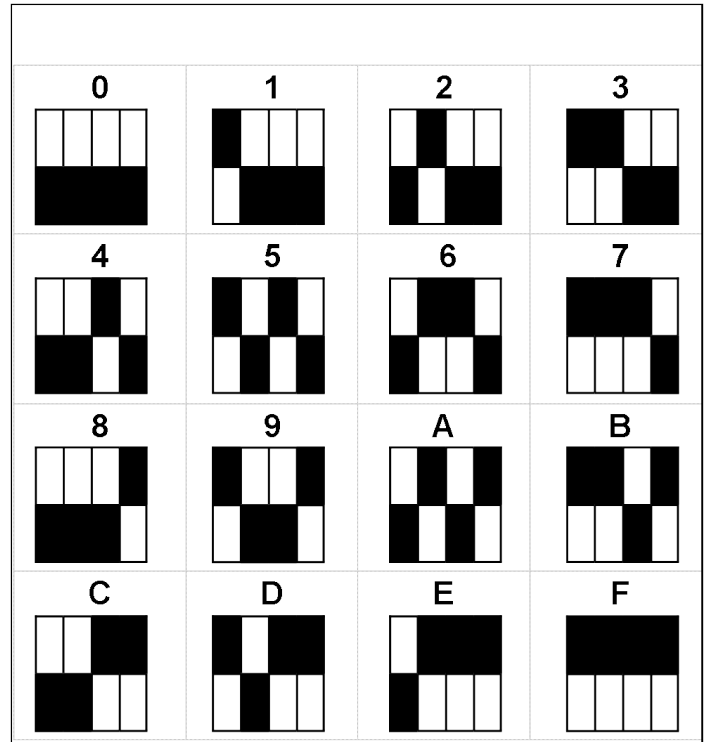
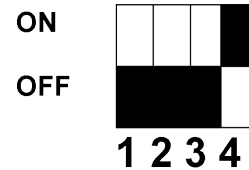

fig. 16. Air curtain address numbers

The black shaded areas represent the switch position.

This example shows the air curtain set to No.8



 **WARNING:**

**THIS AIR CURTAIN SHOULD NOT BE INSTALLED WHERE THERE IS A CORROSIVE ATMOSPHERE**

Bitswitch location on PCB

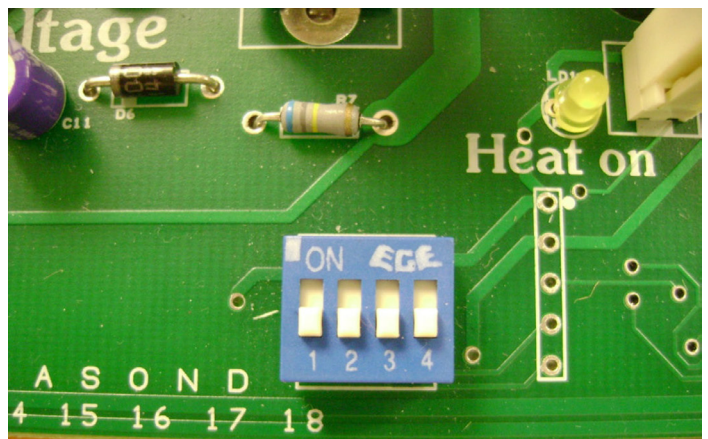

### 11.2.9 Keypad sequences (standard controller)

Standard - Normal display

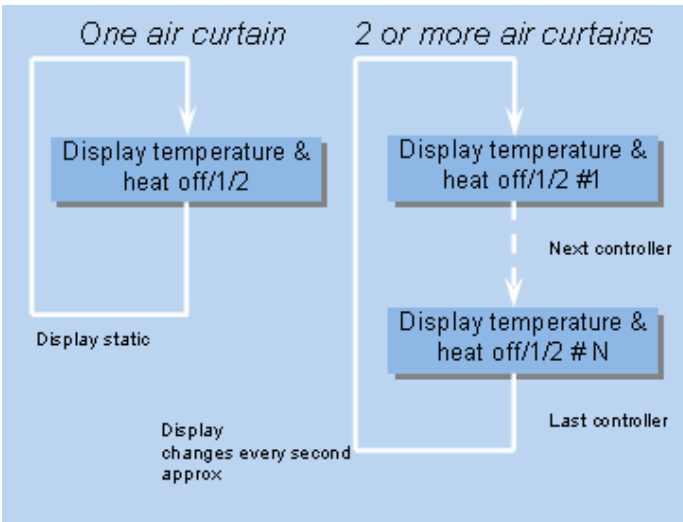

LPHW - Normal display

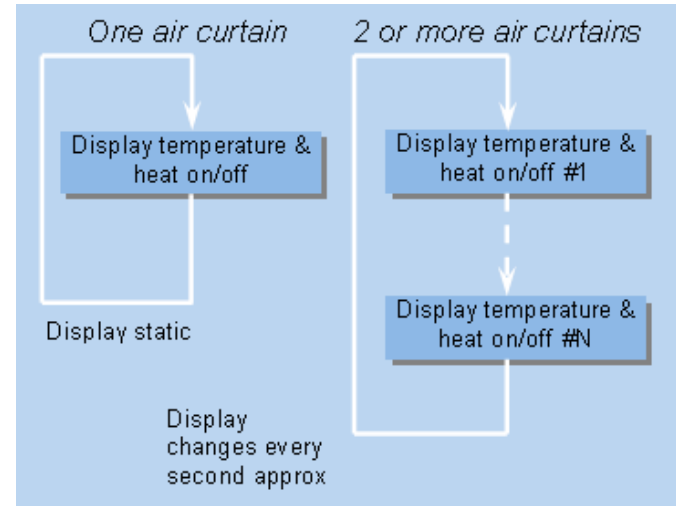

Standard - Normal set-up

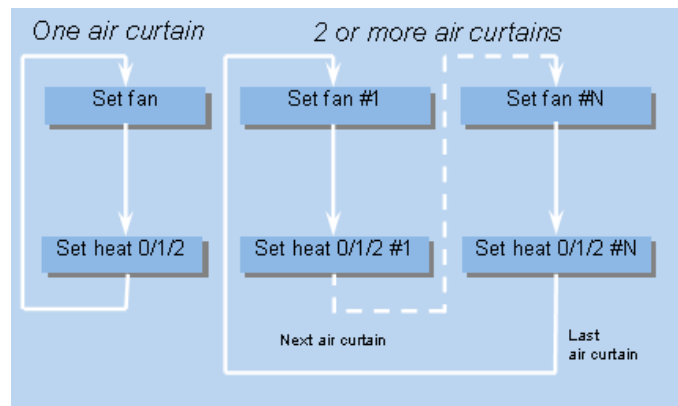

LPHW - Normal set-up

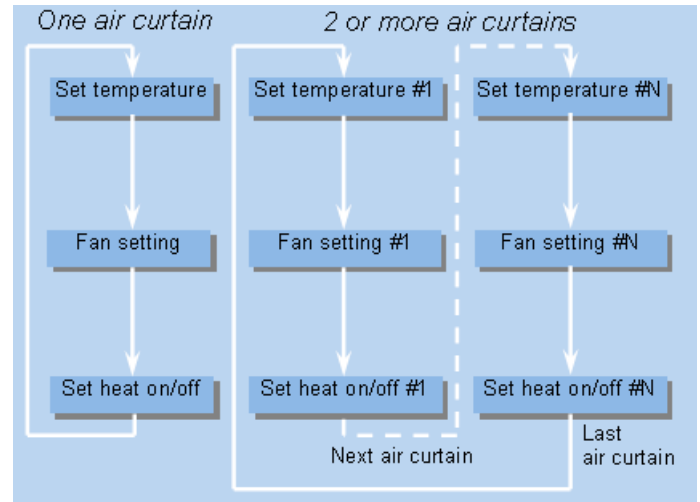

Standard - Engineers mode display

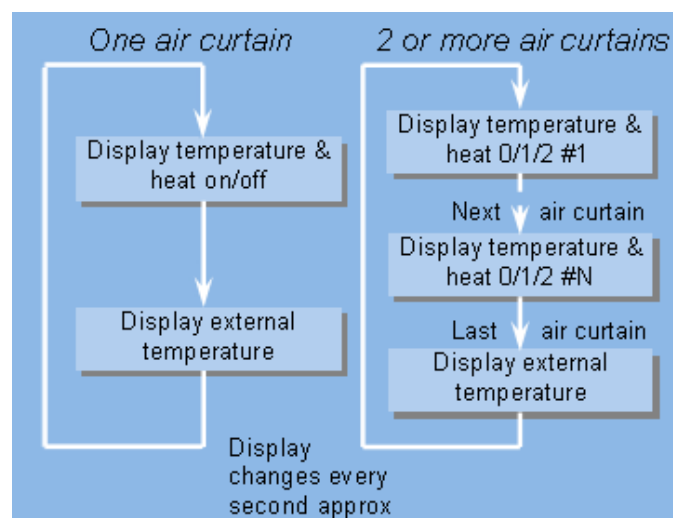

LPHW - Engineers mode display

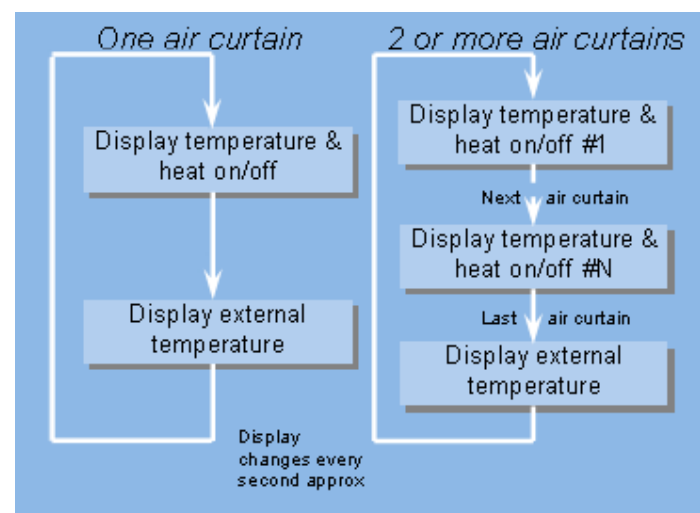

LPHW - Engineers mode set-up

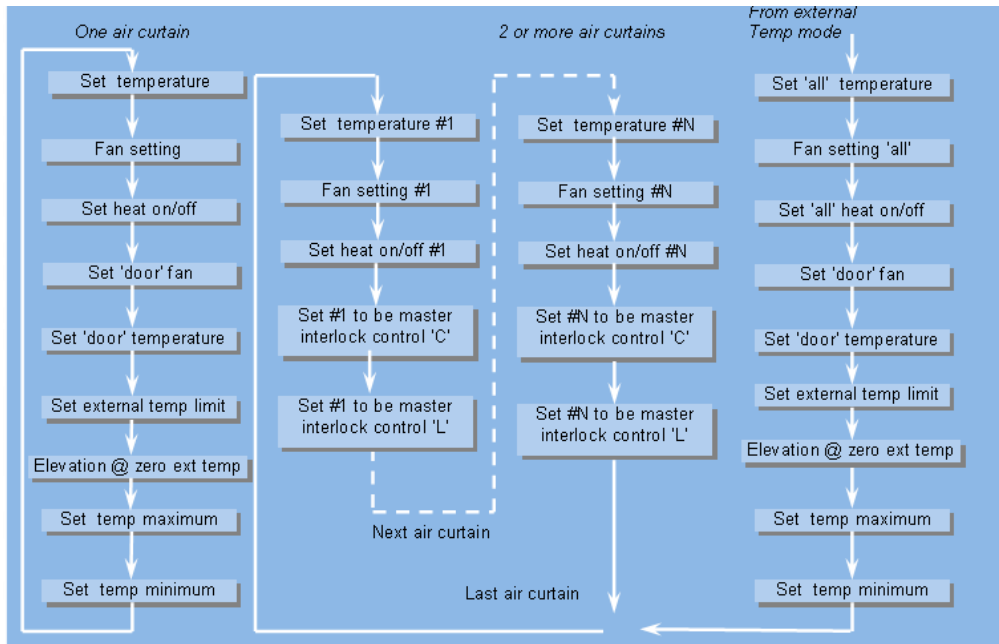

Standard - Engineers mode set-up

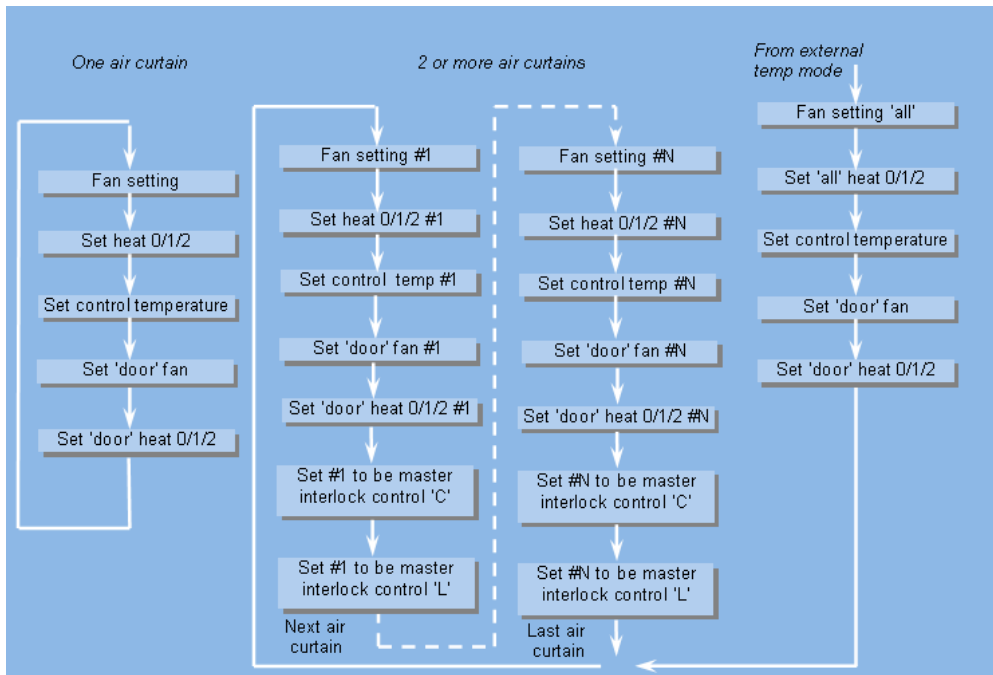

10.2.10 Keypad sequences (SmartElec controller)

Engineers mode display

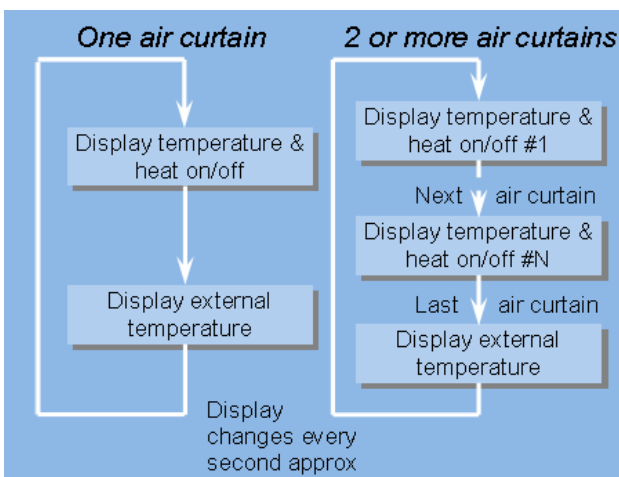

Normal set-up

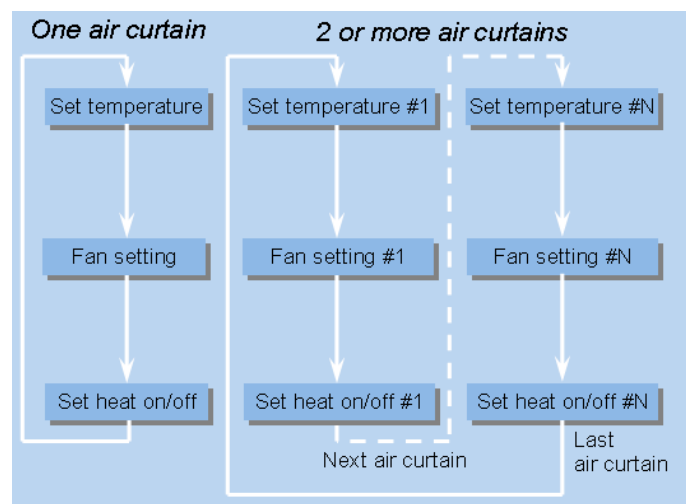

### Normal display

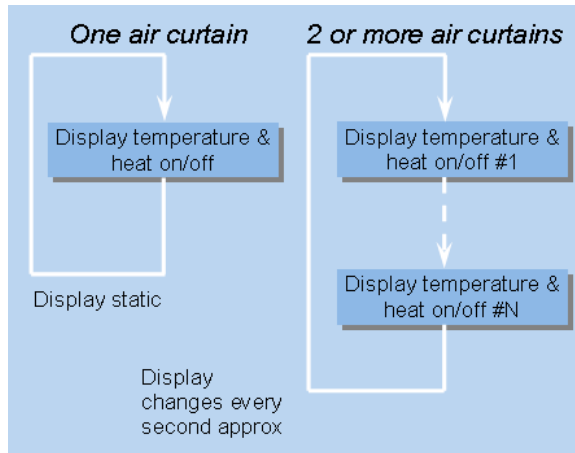

### Engineers mode set-up

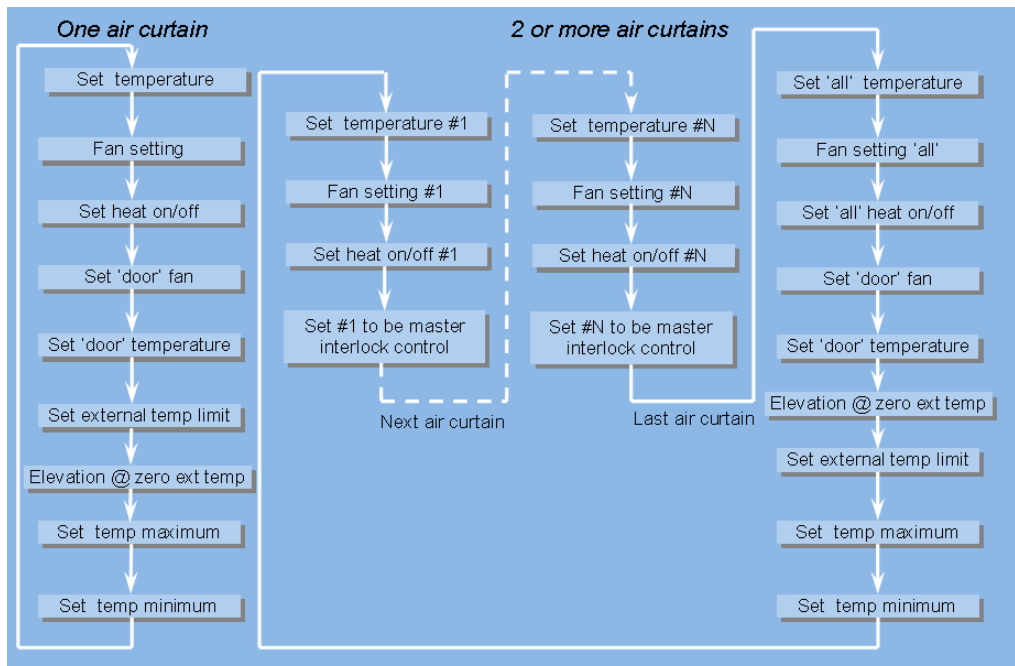



**NORTEK GLOBAL HVAC (UK) LTD**

Fens Pool Avenue  
Brierley Hill  
West Midlands DY5 1QA  
United Kingdom

Tel: **01384 489 250**  
Fax: **01384 489 707**

[airblocsales@nortek.com](mailto:airblocsales@nortek.com)  
[www.ambirad.co.uk](http://www.ambirad.co.uk)

Registered in England No. 01390934. Registered office: 10 Norwich Street, London, EC4A 1BD.  
Nortek Global HVAC is a registered trademark of Nortek Global HVAC Limited. Because of continuous product innovation, Nortek Global HVAC reserves the right to change product specification without due notice.

Document reference number: **D301050**  
Replaces Document reference number: **D301022 R1**