

# AC COMMERCIAL & RETAIL

## ELECTRICALLY HEATED, AMBIENT & LPHW

# INSTALLATION AND OPERATING

# MANUAL

### INDEX

### Section

General information -----	1
Dimensions -----	2
Technical Specification -----	3
Wiring Details -----	4
Installation Details -----	5
Option Light Box Installation -----	6
Option Luminaire Installation -----	7
Servicing & Maintenance -----	8
Spare Parts -----	9
Fault Finding -----	10
Parts replacement -----	11
User Instructions -----	12

### WARNINGS

- 1 This appliance must only be installed by a competent person in accordance with the requirements of the Codes of Practice or the rules in force.
- 2 All external wiring MUST comply with the current IEE wiring regulations.
- 3 Warning this appliance must be earthed.

# Document Index.

## **1 Installation Requirements**

- 1.1 Introduction
- 1.2 General
- 1.3 Electrical Supply
  - 1.3.1 Electronic Controller
  - 1.3.2 SmartElec Controller
- 1.4 Location
- 1.5 Clearance Distance
- 1.6 Health and Safety
- 1.7 Standards

## **2 Dimensions**

- 2.1 AC Air Curtain
- 2.2 AC Chassis Air Curtain
- 2.3 Electronic Controller
- 2.4 Optional SmartElec Controller

## **3 Technical Specifications**

- 3.1 Electrical Heated, Std Capacity 6&9kW 1P
- 3.2 Electrical Heated, Std Capacity 9-18kW
- 3.3 Electrical Heated, High Capacity 12-24kW
- 3.4 Ambient, Std Capacity
- 3.5 Ambient, High Capacity
- 3.6 LPHW, Std Capacity
- 3.7 LPHW, High Capacity
- 3.8 Electronic Controller
- 3.9 SmartElec Controller

## **4 Wiring Diagrams**

- 4.1 Installer Wiring Electrically Heated 6&9kW 1P
- 4.2 Installer Wiring Electrically Heated 9&12kW
- 4.3 Installer Wiring Electrically Heated 18&24kW
- 4.4 Installer Wiring Ambient
- 4.5 Installer Wiring LPHW
- 4.6 Factory Wiring Electrically Heated 6&9kW 1P
- 4.7 Factory Wiring Electrically Heated 9&12kW
- 4.8 Factory Wiring Electrically Heated 18&24kW
- 4.9 Factory Wiring Ambient
- 4.10 Factory Wiring LPHW
- 4.11 Network Wiring Electronic Controller
- 4.12 Installer Wiring SmartElec Controller
- 4.13 Factory Wiring SmartElec Controller
- 4.14 Network Wiring SmartElec Controller

## **5 Installation Requirements**

- 5.1 Mounting
- 5.2 Electrical Supply
- 5.3 Installation
- 5.4 Standard Controller
- 5.5 Option SmartElec Controller
- 5.6 LPHW only
- 5.7 Wiring

## **6 Optional Light Box/Down Lighters**

- 6.1 Dimensions
- 6.2 Installation
- 6.3 Wiring
- 6.4 Rear Panel & Sign Options

## **7 Optional Fire Exit Luminaries**

- 7.1 General
- 7.2 Remote Switching
- 7.3 Commissioning/Testing
- 7.4 Specification
  - 7.4.1 Non-maintained
  - 7.4.2 Maintained
- 7.5 Installation
- 7.6 Wiring Diagram

## **8 Servicing & Maintenance Instructions**

## **9 Spare Parts**

- 9.1 General
- 9.2 AC-ACR-PANEL Controller
- 9.3 SmartElec Controller
- 9.4 Heating mediums

## **10 Fault Finding Guide**

- 10.1 General
- 10.2 Electrical Heated
- 10.3 Electronic Controller
- 10.4 Optional SmartElec Controller
  - 10.4.1 Fault Code chart
  - 10.4.2 LED indication

## **11 Replacing Parts**

- 11.1 Rotor and Motor
- 11.2 Electrical Element

## **12 User and Operating Instructions**

- 12.1 Keypad
- 12.2 Operation
- 12.3 Engineers Settings
  - 12.3.1 Auto Mode
  - 12.3.2 Door Switch Mode
- 12.4 Optional SmartElec Controller
  - 12.4.1 Keypad
  - 12.4.2 Operation
  - 12.4.3 Network Addressing

# General Information

## 1.1 Introduction

This instruction manual describes the Airbloc AC Commercial & Retail range of air curtains.

Models range from 1000mm to 2000mm in length, in both Standard and High capacity and are available in either Electrically Heated, Ambient or LPHW. They are designed for mounting above or slung on drop rods above doorways.

Each air curtain is supplied with a fully electronic controller giving multi fan and heat settings (electrically operated units) via a simple key pad which can be mounted up to 50m from the air curtain. Optional BMS time control, external thermostats and door interlocks can be installed.



fig.1. AC-ACR-PANEL program keypad

The **AC-ACR-PANEL programmer** shown above allows the user to control either a single air curtain, or a network of up to 6 air curtains with the same settings, and provides the following functions:-

- Heat On Off or Auto via optional thermostat
  - Off or Low, Medium and High Fan Speeds
- For further details please refer to section 12.2

Alternatively on electrically heated models, an optional SmartElec control system consists of a base unit (installed within the air curtain) and a program panel that can be installed remote from the air curtain. Usually, the program panel is mounted at a low level from the air curtain for user access and to a maximum distance of 50m. The base unit and program panel are linked by low voltage cable as specified in these instructions.

The **SmartElec factory fitted base unit** provides terminals for 3 phase supply connection and the low voltage program panel wires. The SmartElec base unit rapidly pulses energy to the heating elements. This combined with the inbuilt intelligent sensor control, maintains a fixed outlet temperature, thereby reducing energy consumption as compared to an air curtain without the SmartElec control.



fig.2. SmartElec Controller

The **SmartElec program panel** shown above allows the user to control either a single air curtain, or a network of up to 16 air curtains, each with different settings if required, and provides the following functions:-

- Heat On or Off
- Off or Low, Medium and High Fan Speeds
- Air Outlet Temperature.

For further details please refer to section 12.4

## 1.2 General

All installations must be in accordance with the regulations in force in the country of use.

These instructions must be handed to the user on completion of the installation.

Installers and service engineers must be able to demonstrate competence and be suitably qualified in accordance with the regulations in force in the country of use.

To ensure continued and safe operation it is recommended that the appliance is serviced annually.

The manufacturer, offers a maintenance service. Details are available on request.

The air curtain outlet grille and case air inlet slots must not be obstructed during use.

## 1.3 Electrical Supply

For full electrical loadings, please refer to the individual technical data sheets within this manual.

It is recommended that the electrical supply to the base unit in the air curtain is via an appropriate switched isolator in accordance with the regulations in force in the country of use and must be via a fused isolator having a contact separation of greater than 3mm in all poles.

BMS control, time switches, room thermostats and door interlocks can be installed at the discretion and responsibility of the installer.

All units must be wired in accordance with I.E.E regulations for the Electrical Equipment of Buildings and the installer should ensure that a suitable isolating switch is connected in the mains supply.

**Warning**

For safety reasons a good earth connection must ALWAYS be made to the heater and control box.

**1.3.1 Electronic controller**

Electrically heated supply is either 230V 1 phase (6 and 9kW options) or 415V 3 phase (9 to 24kW), Neutral and Earth. Max cable inlet size is 4mm<sup>2</sup> or 6mm<sup>2</sup> (refer to individual technical specification)

Ambient and LPHW supply is 230V 1 phase, Neutral and Earth. Max cable inlet size is 4mm<sup>2</sup>.

Remote unit is wired to the base unit via a Belden 9174 cable (or direct equiv).

**1.3.2 SmartElec controller**

Electrically heated supply is 415V 3 phase, neutral and earth. Max cable inlet size is 6mm<sup>2</sup>.

Remote unit is wired to the base unit via 2 pairs Belden 9174 cable (or direct equiv).

Networked air curtain interconnects via 2 pairs Belden 9174 cable (or direct equiv).

**1.4 Location**

Airbloc units should be installed horizontally directly over the door opening. It is recommended that the air curtain is installed on the inside of the building, within the open room space against a wall or ceiling. AC chassis units are designed to be positioned in suspended ceilings or bulkheads.

Care must be taken to allow complete free air movement into the inlet grilles of the unit to ensure correct working operation of the air curtain. The discharge opening should be as close to the top of the door as possible and to cover the entire door width.

Units can be mounted adjacent to each other to cover the full door opening across wider entrances.

These units are designed for surface mounting and should not be placed into a ceiling void, due to possible obstruction of airflow and difficulty in routine cleaning and maintenance.

**1.5 Clearance distances**

It is recommended that a minimum clearance of 300mm is allowed around the top and front of the unit. The clearance allows for cable entry and prevents combustible surfaces overheating.

The minimum mounting height (floor to grille outlet) is 1.8m. The recommended maximum mounting height is 3m for standard and 4m for high capacity models.

**1.6 Health and Safety.**

Sole liability rests with the installer to ensure that all site safety procedures are adhered to during installation.

Sole liability rests with the installer to ensure that protective safety wear such as hand, eye, ear and head protection is used during installation of the product.

Do not rest anything especially ladders against the product.

**1.7 Standards**

Units conform to the European electrical standard BS EN 60335-2-30 and to the following European CE directives-

2006/95/EC - low voltage;

2004/108/EC - electromagnetic compatibility.

## 2. Dimensions.

### 2.1 AC Air Curtain

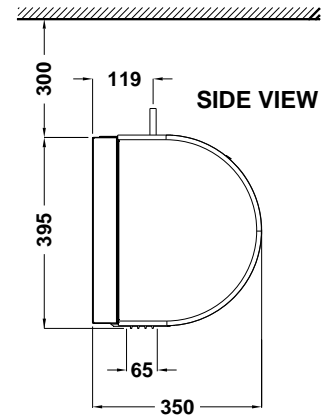
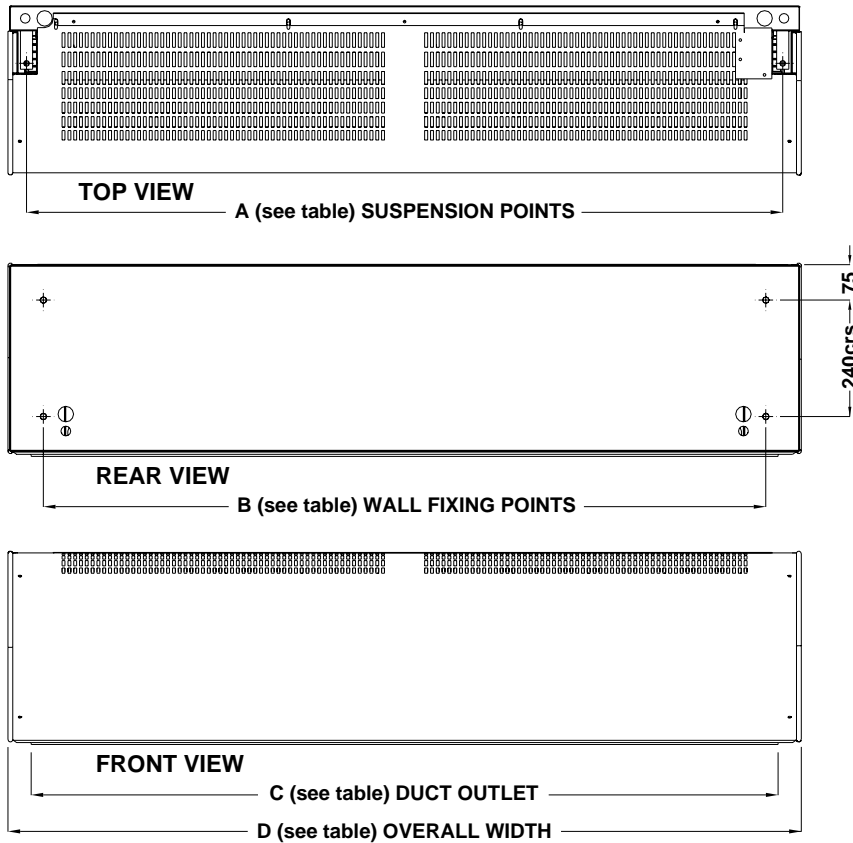

mm	1000	1500	2000
<b>A</b>	1062	1562	2062
<b>B</b>	992	1492	1992
<b>C</b>	1053	1553	2053
<b>D</b>	1138	1638	2138

### 2.2 AC Chassis Air Curtain

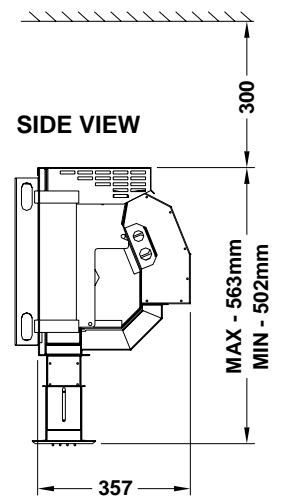
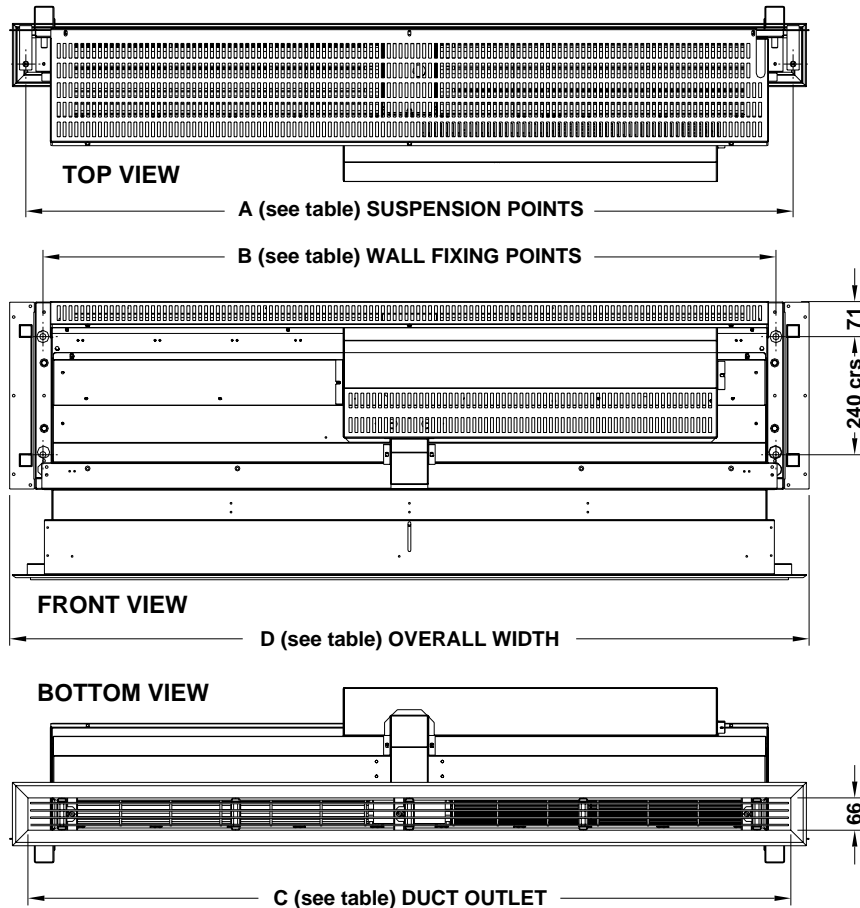

mm	1000	1500	2000
<b>A</b>	1062	1562	2062
<b>B</b>	992	1492	1992
<b>C</b>	1053	1553	2053
<b>D</b>	1138	1638	2138

### 2.3 AC-ACR-PANEL program keypad

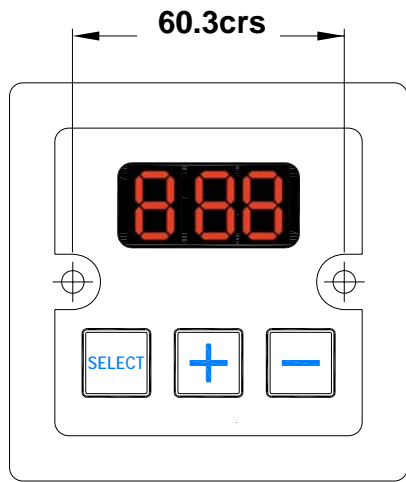

Fig.3. Surface mount

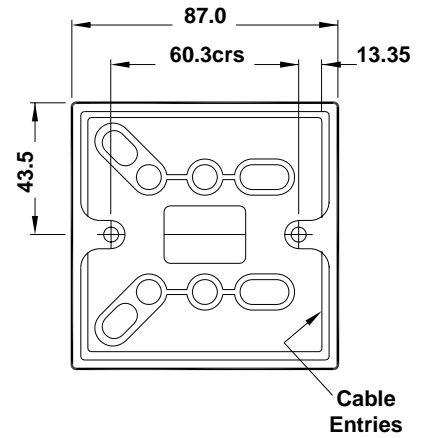
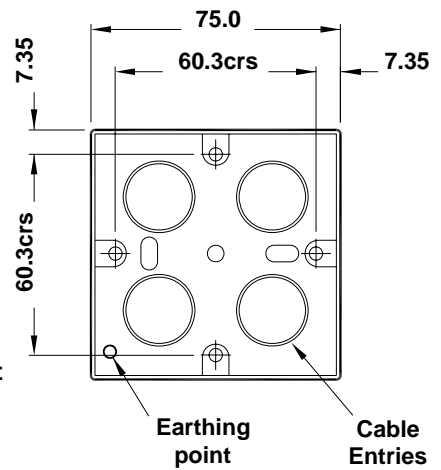
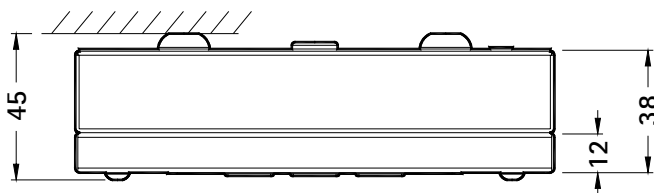
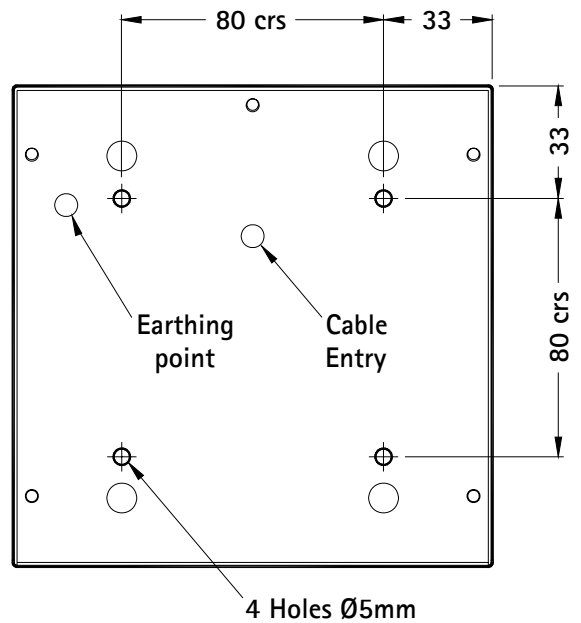
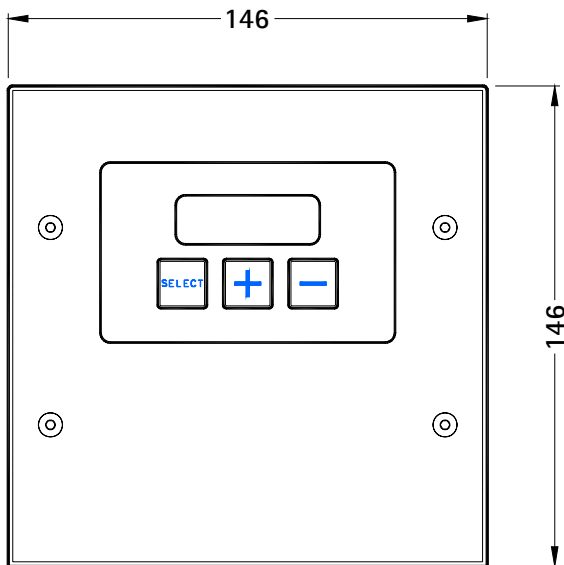

Fig.4. optional flush mount



### 2.4 Optional SmartElec Controller dimensions



## 3. Technical Specification.

3.1 (Single Phase only)			AC1000SE6-1PH	AC1500SE6-1PH	AC2000SE9-1PH
<b>General Data</b>					
Maximum height	M		3.0		
Door width	M		1.0	1.5	2.0
Heat medium			Electric heated		
Heat settings	kW		3 / 6		4.5 / 9
Fan type / dia			Crossflow / 150mm		
Fan settings			3		
Switching type			AC-ACR-PANEL / SmartElec		
Weight	kg		39.5	49.0	60.0
<b>Electrical Data</b>					
Supply voltage			230V 1ph 50Hz		
Total load	kW		6.4		9.4
	amps		27.7		40.7
Motor power	W		370		
Max Starting current*	amps		5.0		
Max Running current*	amps		2.1		
External fuse size amps	amps		32		45
Programmer keypad	pt. no.		AC-ACR-PANEL		
Program keypad control wiring			Belden 9174 (or similar)		
Cable terminal size			6.0mm <sup>2</sup> Max		
Mains terminal block position			Separate din rail L1; N & E		
Control terminal block position			Right side of base unit terminals +12V, DATA & GND		
<b>Air Data</b>					
Air volume	<i>Low speed</i>	m <sup>3</sup> /h	1300	1600	2900
	<i>Medium speed</i>	m <sup>3</sup> /h	1850	2400	4100
	<i>High speed</i>	m <sup>3</sup> /h	2300	3300	5000
Air velocity	<i>Low @ 0M</i>	m/s	6.0		
	<i>Medium @ 0M</i>	m/s	8.5		
	<i>High @ 0M</i>	m/s	11.0		
	<i>High @ 1M</i>	m/s	5.4	5.5	5.2
	<i>High @ 2M</i>	m/s	3.6	3.7	3.6
	<i>High @ 3M</i>	m/s	2.6	2.5	2.4
	Delta T	<i>Low speed</i>	°C	20	13
<i>Medium speed</i>		°C	13	9	10
<i>High speed</i>		°C	11	7	7
Noise level @ 3M in free field	<i>Low speed</i>	dBA	50		
	<i>Medium speed</i>	dBA	55		
	<i>High speed</i>	dBA	60		
<b>Dims Data</b>					
Length	mm		1138	1638	2138
Depth (width)	mm		350		
Height including outlet	mm		395 ( Chassis - min 502 max 563)		
Outlet length	mm		1095	1595	2095
Outlet depth	mm		65		
Outlet height	mm		Flush ( Chassis - min 107 max 168)		
Drop rod mounting rear to centres on depth	mm		119		
Drop rod side to 1st Centre	mm		38		
Drop rod mounting centres on length	mm		1062	1562	2062
Wall mounting side to 1st centre	mm		73		
Wall mounting top to 1st centre	mm		75		
Wall mounting centres on length	mm		992	1492	1992
Wall mounting centres on height	mm		240		

\* Motor current only at high speed

3.2			AC1000SE9	AC1500SE12	AC2000SE18
<b>General Data</b>					
Maximum height	M		3.0		
Door width	M		1.0	1.5	2.0
Heat medium			Electric heated		
Heat setting	kW		4.5 / 9	6 / 12	9 / 18
Fan type / dia			Crossflow / 150mm		
Fan settings			3		
Switching type			AC-ACR-PANEL / SmartElec		
Weight	kg		39.5	49.0	60.0
<b>Electrical Data</b>					
Supply voltage			415V 3ph 50Hz		
Total load	kW		9.4	12.4	18.4
	A/pha		13.1	17.3	25.6
Motor power	W		370		
Max Starting current*	amps		5.0		
Max Running current*	amps		2.1		
External fuse size amps	A/pha		16	20	32
Programmer keypad	pt. no.		AC-ACR-PANEL		
Program keypad control wiring			Belden 9174 (or similar)		
Cable terminal size			4.0mm <sup>2</sup> Max		6.0mm <sup>2</sup> Max
Mains terminal block position			Bottom of base unit. Terminals N; L1; L2 & L3		Separate din rail E: N; L1; L2 & L3
Control terminal block position			Right side of base unit terminals +12V, DATA & GND		
** SmartElec Energy Saving Control	pt. no.		102609		
SmartElec Energy Saving Control wiring			2 x pair Belden 9174 (or similar)		
Cable terminal size			6.0mm <sup>2</sup> Max		
Mains terminal block position			SmartElec Base Unit - terminals N; L1; L2 & L3		
Control terminal block position			SmartElec Base Unit - terminals A; B; 0V & 7V		
<b>Air Data</b>					
Air volume	<i>Low speed</i>	m <sup>3</sup> /h	1300	1600	2900
	<i>Medium speed</i>	m <sup>3</sup> /h	1850	2400	4100
	<i>High speed</i>	m <sup>3</sup> /h	2300	3300	5000
Air velocity	<i>Low @ 0M</i>	m/s	6.0		
	<i>Medium @ 0M</i>	m/s	8.5		
	<i>High @ 0M</i>	m/s	11.0		
	<i>High @ 1M</i>	m/s	5.4	5.5	5.2
	<i>High @ 2M</i>	m/s	3.6	3.7	3.6
	<i>High @ 3M</i>	m/s	2.6	2.5	2.4
	Delta T	<i>Low speed</i>	°C	30	26
<i>Medium speed</i>		°C	22	18	19
<i>High speed</i>		°C	17	15	15
Noise level @ 3M in free field	<i>Low speed</i>	dBA	50		
	<i>Medium speed</i>	dBA	55		
	<i>High speed</i>	dBA	60		
<b>Dims Data</b>					
Length	mm		1138	1638	2138
Depth (width)	mm		350		
Height including outlet	mm		395 ( Chassis - min 502 max 563)		
Outlet length	mm		1095	1595	2095
Outlet depth	mm		65		
Outlet height	mm		Flush ( Chassis - min 107 max 168)		
Drop rod mounting rear to centres on depth	mm		119		
Drop rod side to 1st Centre	mm		38		
Drop rod mounting centres on length	mm		1062	1562	2062
Wall mounting side to 1st centre	mm		73		
Wall mounting top to 1st centre	mm		75		
Wall mounting centres on length	mm		992	1492	1992
Wall mounting centres on height	mm	8	240		

\* Motor current only at high speed

\*\*Suffix with -SM for SmartElec Energy Saving Control.

3.3			AC1000HE12	AC1500HE18	AC2000HE24
<b>General Data</b>					
Maximum height	M		4.0		
Door width	M	1.0	1.5	2.0	
Heat medium		Electric heated			
Heat setting	kW	6 / 12	9 / 18	12 / 24	
Fan type / dia		Crossflow / 150mm			
Fan settings		3			
Switching type		AC-ACR-PANEL / SmartElec			
Weight	kg	39.5	49.0	60.0	
<b>Electrical Data</b>					
Supply voltage		415V 3ph 50Hz			
Total load	kW	12.4	18.4	24.4	
	A/pha	17.3	25.6	34.0	
Motor power	W	370			
Max Starting current*	amps	5.0			
Max Running current*	amps	2.1			
External fuse size amps	A/pha	20	32	40	
Programmer keypad	pt. no.	AC-ACR-PANEL			
Program keypad control wiring		Belden 9174 (or similar)			
Cable terminal size		4.0mm <sup>2</sup> Max	6.0mm <sup>2</sup> Max		
Mains terminal block position		Base unit N; L1; L2 & L3	Separate din rail E; N; L1; L2 & L3		
Control terminal block position		Right side of base unit terminals +12V, DATA & GND			
** SmartElec Energy Saving Control	pt. no.	102609			
SmartElec Energy Saving Control wiring		2 x pair Belden 9174 (or similar)			
Cable terminal size		6.0mm <sup>2</sup> Max			
Mains terminal block position		SmartElec Base Unit - terminals N; L1; L2 & L3			
Control terminal block position		SmartElec Base Unit - terminals A; B; 0V & 7V			
<b>Air Data</b>					
Air volume	<i>Low speed</i>	m <sup>3</sup> /h	1300	1600	2900
	<i>Medium speed</i>	m <sup>3</sup> /h	1850	2400	4100
	<i>High speed</i>	m <sup>3</sup> /h	2300	3300	5000
Air velocity	<i>Low @ 0M</i>	m/s	6.0		
	<i>Medium @ 0M</i>	m/s	8.5		
	<i>High @ 0M</i>	m/s	11.0		
	<i>High @ 1M</i>	m/s	5.4	5.5	5.2
	<i>High @ 2M</i>	m/s	3.6	3.7	3.6
	<i>High @ 3M</i>	m/s	2.6	2.5	2.4
	<i>High @ 4M</i>	m/s	1.5	1.6	1.4
Delta T	<i>Low speed</i>	°C	35	35	36
	<i>Medium speed</i>	°C	28	27	26
	<i>High speed</i>	°C	22	22	20
Noise level @ 3M in free field	<i>Low speed</i>	dBA	50		
	<i>Medium speed</i>	dBA	55		
	<i>High speed</i>	dBA	60		
<b>Dims Data</b>					
Length	mm	1138	1638	2138	
Depth (width)	mm	350			
Height including outlet	mm	395 ( Chassis - min 502 max 563)			
Outlet length	mm	1095	1595	2095	
Outlet depth	mm	65			
Outlet height	mm	Flush ( Chassis - min 107 max 168)			
Drop rod mounting rear to centres on depth	mm	119			
Drop rod side to 1st Centre	mm	38			
Drop rod mounting centres on length	mm	1062	1562	2062	
Wall mounting side to 1st centre	mm	73			
Wall mounting top to 1st centre	mm	75			
Wall mounting centres on length	mm	992	1492	1992	
Wall mounting centres on height	mm	240			

\* Motor current only at high speed

\*\*Suffix with -SM for SmartElec Energy Saving Control.

3.4			AC1000SA	AC1500SA	AC2000SA
<b>General Data</b>					
Maximum height	M		3.0		
Door width	M	1.0	1.5	2.0	
Heat medium		Ambient			
Fan type / dia		Crossflow / 150mm			
Fan settings		3			
Switching type		AC-ACR-PANEL			
Weight	kg	39.5	49.0	60.0	
<b>Electrical Data</b>					
Supply voltage		230V 1ph 50Hz			
Total load	kW	0.4			
	amps	1.61			
Motor power	W	370			
Max Starting current*	amps	5.0			
Max Running current*	amps	2.1			
External fuse size amps	amps	10			
Programmer keypad	pt. no.	AC-ACR-PANEL			
Program keypad control wiring		Belden 9174 (or similar)			
Cable terminal size		4.0mm <sup>2</sup> Max			
Mains terminal block position		Base unit L1; N + E			
Control terminal block position		Right side of base unit terminals +12V, DATA & GND			
<b>Air Data</b>					
Air volume	<i>Low speed</i>	m <sup>3</sup> /h	1300	1600	2900
	<i>Medium speed</i>	m <sup>3</sup> /h	1850	2400	4100
	<i>High speed</i>	m <sup>3</sup> /h	2300	3300	5000
Air velocity	<i>Low @ 0M</i>	m/s	6.0		
	<i>Medium @ 0M</i>	m/s	8.5		
	<i>High @ 0M</i>	m/s	11.0		
	<i>High @ 1M</i>	m/s	5.4	5.5	5.2
	<i>High @ 2M</i>	m/s	3.6	3.7	3.6
	<i>High @ 3M</i>	m/s	2.6	2.5	2.4
Noise level @ 3M in free field	<i>Low speed</i>	dBA	50		
	<i>Medium speed</i>	dBA	55		
	<i>High speed</i>	dBA	60		
<b>Dims Data</b>					
Length	mm	1138	1638	2138	
Depth (width)	mm	350			
Height including outlet	mm	395 ( Chassis - min 502 max 563)			
Outlet length	mm	1095	1595	2095	
Outlet depth	mm	65			
Outlet height	mm	Flush ( Chassis - min 107 max 168)			
Drop rod mounting rear to centres on depth	mm	119			
Drop rod side to 1st Centre	mm	38			
Drop rod mounting centres on length	mm	1062	1562	2062	
Wall mounting side to 1st centre	mm	73			
Wall mounting top to 1st centre	mm	75			
Wall mounting centres on length	mm	992	1492	1992	
Wall mounting centres on height	mm	240			

\* Motor current only at high speed

3.5			AC1000HA	AC1500HA	AC2000HA
<b>General Data</b>					
Maximum height	M		3.0		
Door width	M	1.0	1.5	2.0	
Heat medium		Ambient			
Fan type / dia		Crossflow / 150mm			
Fan settings		3			
Switching type		AC-ACR-PANEL			
Weight	kg	39.5	49.0	60.0	
<b>Electrical Data</b>					
Supply voltage		230V 1ph 50Hz			
Total load	kW	0.4			
	amps	1.6			
Motor power	W	370			
Max Starting current*	amps	5.0			
Max Running current*	amps	2.1			
External fuse size amps	amps	10			
Programmer keypad	pt. no.	AC-ACR-PANEL			
Program keypad control wiring		Belden 9174 (or similar)			
Cable terminal size		4.0mm <sup>2</sup> Max			
Mains terminal block position		Base unit L1; N + E			
Control terminal block position		Right side of base unit terminals +12V, DATA & GND			
<b>Air Data</b>					
Air volume	<i>Low speed</i>	m <sup>3</sup> /h	1300	1600	2900
	<i>Medium speed</i>	m <sup>3</sup> /h	1850	2400	4100
	<i>High speed</i>	m <sup>3</sup> /h	2300	3300	5000
Air velocity	<i>Low @ 0M</i>	m/s	6.0		
	<i>Medium @ 0M</i>	m/s	8.5		
	<i>High @ 0M</i>	m/s	11.0		
	<i>High @ 1M</i>	m/s	5.4	5.5	5.2
	<i>High @ 2M</i>	m/s	3.6	3.7	3.6
	<i>High @ 3M</i>	m/s	2.6	2.5	2.4
	Noise level @ 3M <i>in free field</i>	<i>Low speed</i>	dBA	50	
<i>Medium speed</i>		dBA	55		
<i>High speed</i>		dBA	60		
<b>Dims Data</b>					
Length	mm	1138	1638	2138	
Depth (width)	mm	350			
Height including outlet	mm	395 ( Chassis - min 502 max 563)			
Outlet length	mm	1095	1595	2095	
Outlet depth	mm	65			
Outlet height	mm	Flush ( Chassis - min 107 max 168)			
Drop rod mounting rear to centres on depth	mm	119			
Drop rod side to 1st Centre	mm	38			
Drop rod mounting centres on length	mm	1062	1562	2062	
Wall mounting side to 1st centre	mm	73			
Wall mounting top to 1st centre	mm	75			
Wall mounting centres on length	mm	992	1492	1992	
Wall mounting centres on height	mm	240			

\* Motor current only at high speed

3.6			AC1000SW9	AC1500SW12	AC2000SW18
<b>General Data</b>					
Maximum height	M			3.0	
Door width	M		1.0	1.5	2.0
Heat medium			LPHW		
Heat setting	kW		9	12	18
Fan type / dia			Crossflow / 150mm		
Fan settings			3		
Switching type			AC-ACR-PANEL		
Weight	kg		39.5	49.0	60.0
<b>Electrical Data</b>					
Supply voltage			230V 1ph 50Hz		
Total load	kW		0.4		
	amps		1.6		
Motor power	W		370		
Max Starting current*	amps		5.0		
Max Running current*	amps		2.1		
External fuse size amps	A/pha		10		
Programmer keypad	pt. no.		AC-ACR-PANEL		
Program keypad control wiring			Belden 9174 (or similar)		
Cable terminal size			4.0mm <sup>2</sup> Max		
Mains terminal block position			Base unit L1; N + E		
Control terminal block position			Right side of base unit terminals +12V, DATA & GND		
<b>Air Data</b>					
Air volume	<i>Low speed</i>	m <sup>3</sup> /h	1300	1600	2900
	<i>Medium speed</i>	m <sup>3</sup> /h	1850	2400	4100
	<i>High speed</i>	m <sup>3</sup> /h	2300	3300	5000
Air velocity	<i>Low @ 0M</i>	m/s	6.0		
	<i>Medium @ 0M</i>	m/s	8.5		
	<i>High @ 0M</i>	m/s	11.0		
	<i>High @ 1M</i>	m/s	5.4	5.5	5.2
	<i>High @ 2M</i>	m/s	3.6	3.7	3.6
	<i>High @ 3M</i>	m/s	2.6	2.5	2.4
	Delta T	<i>Low speed</i>	°C	30	26
<i>Medium speed</i>		°C	22	18	19
<i>High speed</i>		°C	17	15	15
Noise level @ 3M in free field	<i>Low speed</i>	dBA	50		
	<i>Medium speed</i>	dBA	55		
	<i>High speed</i>	dBA	60		
<b>LPHW Data</b>					
LPHW flow	l/s		0.20	0.27	0.40
Fluid pressure drop	kPA		23.0	15.0	
Flow & return connection	mm		15		
Inlet temp	°C		82		
Outlet temp	°C		71		
<b>Dims Data</b>					
Length	mm		1138	1638	2138
Depth (width)	mm		350		
Height including outlet	mm		395 ( Chassis - min 502 max 563)		
Outlet length	mm		1095	1595	2095
Outlet depth	mm		65		
Outlet height	mm		Flush ( Chassis - min 107 max 168)		
Drop rod mounting rear to centres on depth	mm		119		
Drop rod side to 1st Centre	mm		38		
Drop rod mounting centres on length	mm		1062	1562	2062
Wall mounting side to 1st centre	mm		73		
Wall mounting top to 1st centre	mm		75		
Wall mounting centres on length	mm		992	1492	1992
Wall mounting centres on height	mm		240		

\* Motor current only at high speed

3.7			AC1000HW12	AC1500HW18	AC2000HW24
<b>General Data</b>					
Maximum height	M		4.0		
Door width	M	1.0	1.5	2.0	
Heat medium		LPHW			
Heat setting	kW	12	18	24	
Fan type / dia		Crossflow / 150mm			
Fan settings		3			
Switching type		AC-ACR-PANEL			
Weight	kg	39.5	49.0	60.0	
<b>Electrical Data</b>					
Supply voltage		230V 1ph 50Hz			
Total load	kW	0.4			
	amps	1.61			
Motor power	W	370			
Max Starting current*	amps	5.0			
Max Running current*	amps	2.1			
External fuse size amps	A/pha	10			
Programmer keypad	pt. no.	AC-ACR-PANEL			
Program keypad control wiring		Belden 9174 (or similar)			
Cable terminal size		4.0mm <sup>2</sup> Max			
Mains terminal block position		Base unit L1; N + E			
Control terminal block position		Right side of base unit terminals +12V, DATA & GND			
<b>Air Data</b>					
Air volume	<i>Low speed</i>	m <sup>3</sup> /h	1300	1600	2900
	<i>Medium speed</i>	m <sup>3</sup> /h	1850	2400	4100
	<i>High speed</i>	m <sup>3</sup> /h	2300	3300	5000
Air velocity	<i>Low @ 0M</i>	m/s	6.0		
	<i>Medium @ 0M</i>	m/s	8.5		
	<i>High @ 0M</i>	m/s	11.0		
	<i>High @ 1M</i>	m/s	5.4	5.5	5.2
	<i>High @ 2M</i>	m/s	3.6	3.7	3.6
	<i>High @ 3M</i>	m/s	2.6	2.5	2.4
	<i>High @ 4M</i>	m/s	1.5	1.6	1.4
Delta T	<i>Low speed</i>	°C	35	35	36
	<i>Medium speed</i>	°C	28	27	26
	<i>High speed</i>	°C	22	22	20
Noise level @ 3M <i>in free field</i>	<i>Low speed</i>	dBA	50		
	<i>Medium speed</i>	dBA	55		
	<i>High speed</i>	dBA	60		
<b>LPHW Data</b>					
LPHW flow	l/s	0.27	0.40	0.53	
Fluid pressure drop	kPA	19	23	24	
Flow & return connection	mm	15			
Inlet temp	°C	82			
Outlet temp	°C	71			
<b>Dims Data</b>					
Length	mm	1138	1638	2138	
Depth (width)	mm	350			
Height including outlet	mm	395 ( Chassis - min 502 max 563)			
Outlet length	mm	1095	1595	2095	
Outlet depth	mm	65			
Outlet height	mm	Flush ( Chassis - min 107 max 168)			
Drop rod mounting rear to centres on depth	mm	119			
Drop rod side to 1st Centre	mm	38			
Drop rod mounting centres on length	mm	1062	1562	2062	
Wall mounting side to 1st centre	mm	73			
Wall mounting top to 1st centre	mm	75			
Wall mounting centres on length	mm	992	1492	1992	
Wall mounting centres on height	mm	240			

\* Motor current only at high speed

<b>3.8</b>		<b>Program Controller</b>
<b>General Data</b>		
Sensor input	NTC	
Protection	2 x 'slow blow' fuse for the protection of the heater switching devices.	
Fan Output	3 off Relay for High, Medium and Low Fan setting 3A max 240Vac	
Connection	Screw terminals 4 for supply, 6 for heater output, 4 for fan output, 2 for BMS (time) control, 2 for sensor input, 2 for external thermal trip, 2 for external door switch.	
Supply	230V 1Ph or 415 3Ph dependent on model type.	
Dimensions	Program panel 88mm(L) x 88mm(W) max.	
Mounting positions	Program panel fixing centres 60.3mm	
Temperature	5 to 50 °C operating; -20 to 65 °C storage	
Display	Three 7-segment LCD red for parameter display	
Push buttons	3 positive feedback tactile push buttons	

<b>3.9</b>		<b>SmartElec Controller</b>
<b>General Data</b>		
Sensor input	NTC	
Control Setpoint	16 to 35 °C in steps of 1 degree	
Temperature Control	Proportional with 1°C hysteresis	
Minimum Power	30% to 99 %	
Cycle time	0.3 seconds fixed	
Protection	2 x high speed fuse for the protection of the heater switching devices	
Fan Output	3 off Relay for High, Medium and Low Fan setting 3A max 240Vac	
Connection	Screw terminals 4 for supply, 3 for heater output, 4 for fan output, 2 for BMS (time) control, 2 for sensor input, 2 for external thermal trip	
Supply	415 Vrms +/-15% 50/60Hz 5VA max.	
Dimensions	Program panel 101mm(L) x 101mm(W) x 60mm(D) max.	
Mounting positions	Program panel fixing centres 80mm x 80mm	
Temperature	5 to 50 °C operating; -20 to 65 °C storage	
Display	Three 7-segment LCD red for parameter display	
Push buttons	3 positive feedback tactile push buttons	

# 4. Wiring Diagrams.

## 4.1 Installer Wiring - Electrically Heated 6 & 9kW SINGLE PHASE ONLY

The program panel is connected to the base unit via a set of 3 way connectors marked "+12V", "DATA" and "GND". Interconnecting wiring is via Belden 9174 or equivalent cable as shown. **Max length 50m.**

It is recommended that this control cable is run separately within its own trunking to avoid external interference.

Door switch to be volt free and wired normally closed contacts to terminals D1, D2. (Contacts broken when door is open).

External switch (ie BMS enable) to be volt free and wired via normally open contacts to terminals B1, B2.

Optional internal/external sensor to be wired to terminals S1, S2.

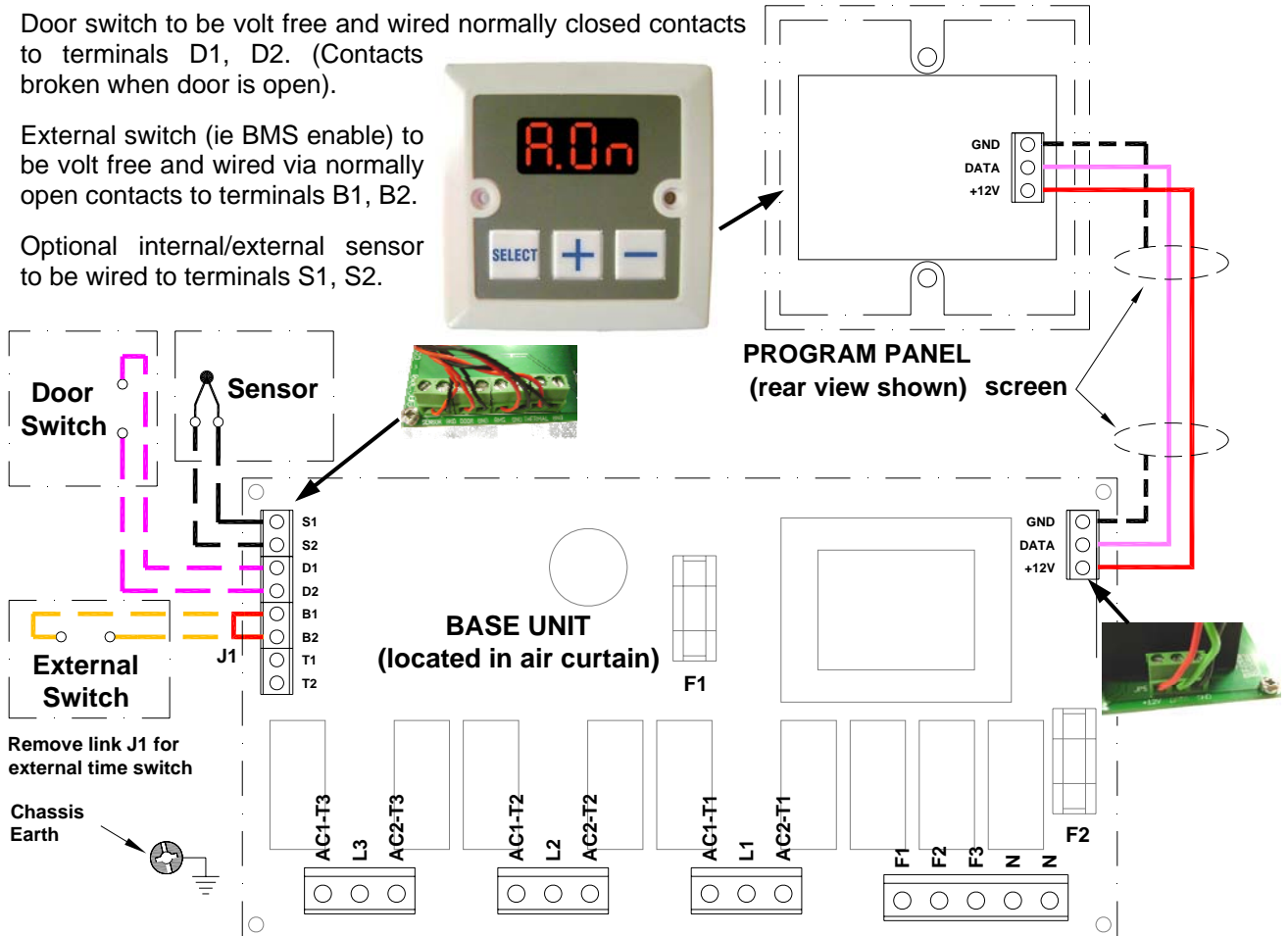

### Contractors Terminal

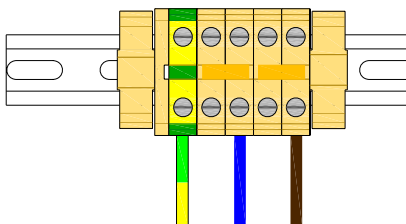

**230V 50Hz  
Mains Supply**

### Protection

External circuit breaker with the appropriate rating should be installed for the protection of the installation.

Terminal	Description	Cable
N	Neutral	6mm <sup>2</sup> max
L1	1 phase supply	6mm <sup>2</sup> max
Pcb Terminal	Description	Cable 1.0mm <sup>2</sup> max
+12V	Supply to remote unit	
DATA	Data to remote unit	
GND(s)	0v Terminal	
D1, D2	Option door contact	
B1, B2	Option BMS switch	
S1, S2	Option internal/external sensor	
Pcb Fuses	Rating (A)	
F1	T2A (slow blow)	
F2	T3.15A (slow blow)	

## 4.2 Installer Wiring - Electrically Heated 9 & 12kW THREE PHASE ONLY

The program panel is connected to the base unit via a set of 3 way connectors marked "+12V", "DATA" and "GND". Interconnecting wiring is via Belden 9174 or equivalent cable as shown. **Max length 50m.**

It is recommended that this control cable is run separately within its own trunking to avoid external interference.

Door switch to be volt free and wired normally closed contacts to terminals D1, D2. (Contacts broken when door is open).

External switch (ie BMS enable) to be volt free and wired via normally open contacts to terminals B1, B2.

Optional internal/external sensor to be wired to terminals S1, S2.

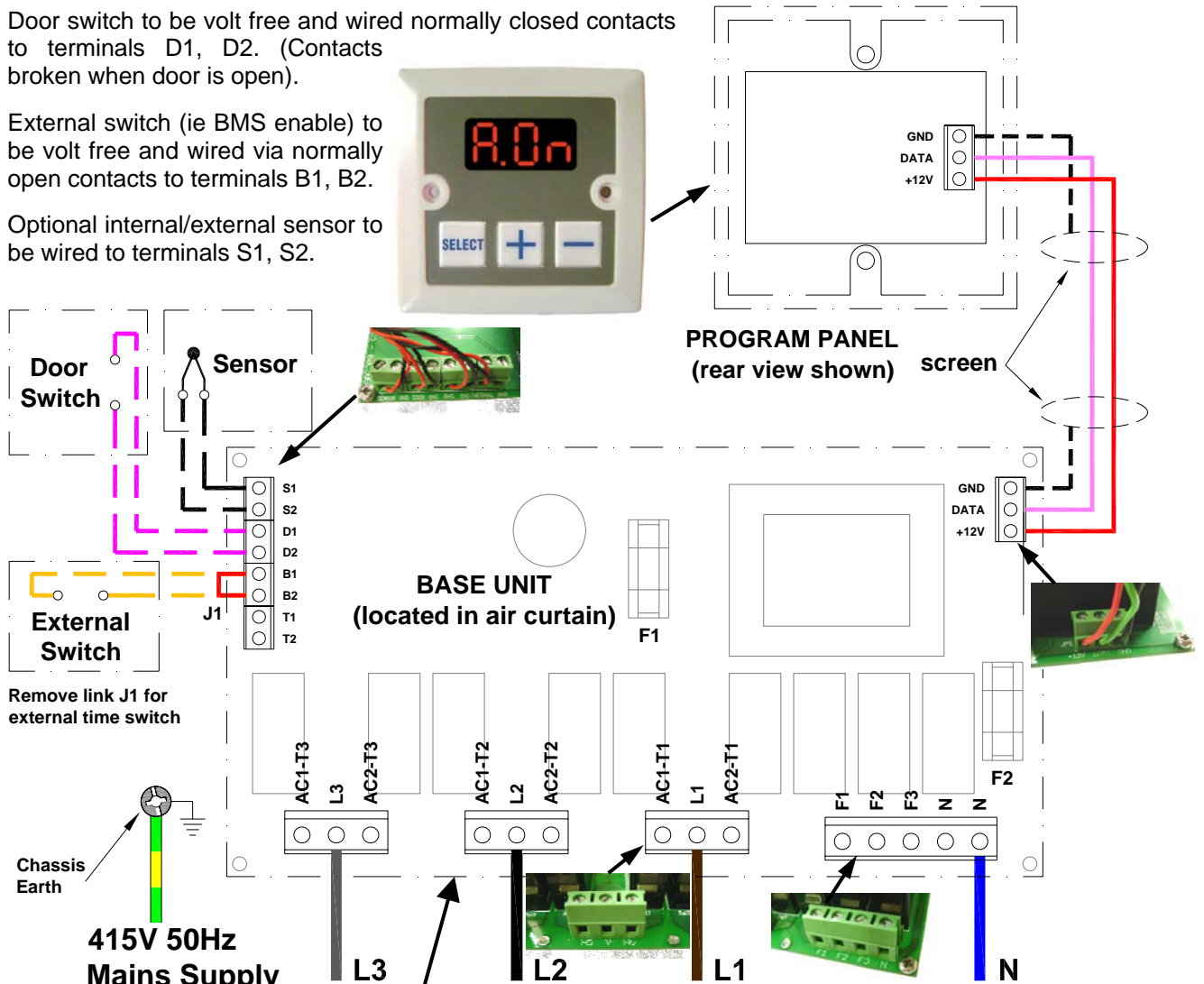

### Protection

External circuit breaker with the appropriate rating should be installed for the protection of the installation.

Pcb Terminal	Description	Cable
N	Neutral	4mm <sup>2</sup> max
L1	3 phase supply	4mm <sup>2</sup> max
L2	3 phase supply	4mm <sup>2</sup> max
L3	3 phase supply	4mm <sup>2</sup> max
+12V	Supply to remote unit	Cable 1.0mm <sup>2</sup> max
DATA	Data to remote unit	
GND(s)	0v Terminal	
D1, D2	option door contact	
B1, B2	option BMS switch	
S1, S2	option internal/external Sensor	
Pcb Fuses		Rating (A)
F1		T2A (slow blow)
F2		T3.15A (slow blow)

### 4.3 Installer Wiring - Electrically Heated 18 & 24kW THREE PHASE ONLY

The program panel is connected to the base unit via a set of 3 way connectors marked "+12V", "DATA" and "GND". Interconnecting wiring is via Belden 9174 or equivalent cable as shown. **Max length 50m.**

It is recommended that this control cable is run separately within its own trunking to avoid external interference.

Door switch to be volt free and wired normally closed contacts to terminals D1, D2. (Contacts broken when door is open).

External switch (ie BMS enable) to be volt free and wired via normally open contacts to terminals B1, B2.

Optional internal/external sensor to be wired to terminals S1, S2.

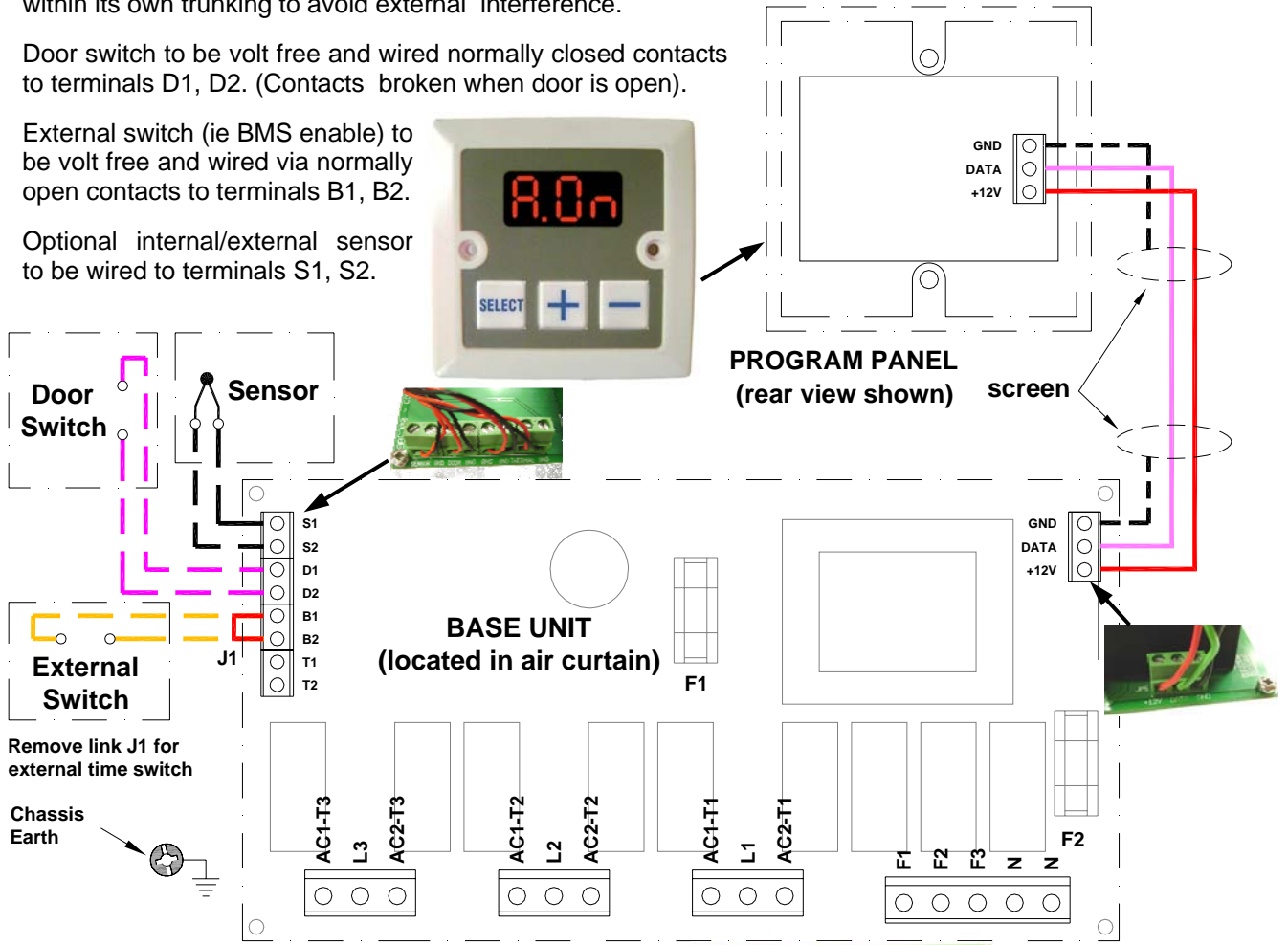

#### Contractors Terminal

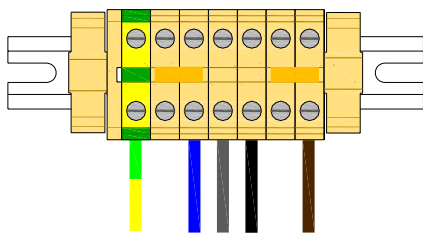

**415V 50Hz  
Mains Supply**

#### Protection

External circuit breaker with the appropriate rating should be installed for the protection of the installation.

Terminal	Description	Cable
N	Neutral	6mm <sup>2</sup> max
L1	3 phase supply	6mm <sup>2</sup> max
L2	3 phase supply	6mm <sup>2</sup> max
L3	3 phase supply	6mm <sup>2</sup> max
Pcb Terminal	Description	Cable
+12V	Supply to remote unit	Cable 1.0mm <sup>2</sup> max
DATA	Data to remote unit	
GND(s)	0v Terminal	
D1, D2	Option door contact	
B1, B2	Option BMS switch	
S1, S2	Option internal/external sensor	
Pcb Fuses	Rating (A)	
F1	T2A (slow blow)	
F2	T3.15A (slow blow)	

#### 4.4 Installer Wiring - Ambient

The program panel is connected to the base unit via a set of 3 way connectors marked "+12V", "DATA" and "GND". Interconnecting wiring is via Belden 9174 or equivalent cable as shown. **Max length 50m.**

It is recommended that this control cable is run separately within its own trunking to avoid external interference.

Door switch to be volt free and wired normally closed contacts to terminals D1, D2. (Contacts broken when door is open).

External switch (ie BMS enable) to be volt free and wired via normally open contacts to terminals B1, B2.

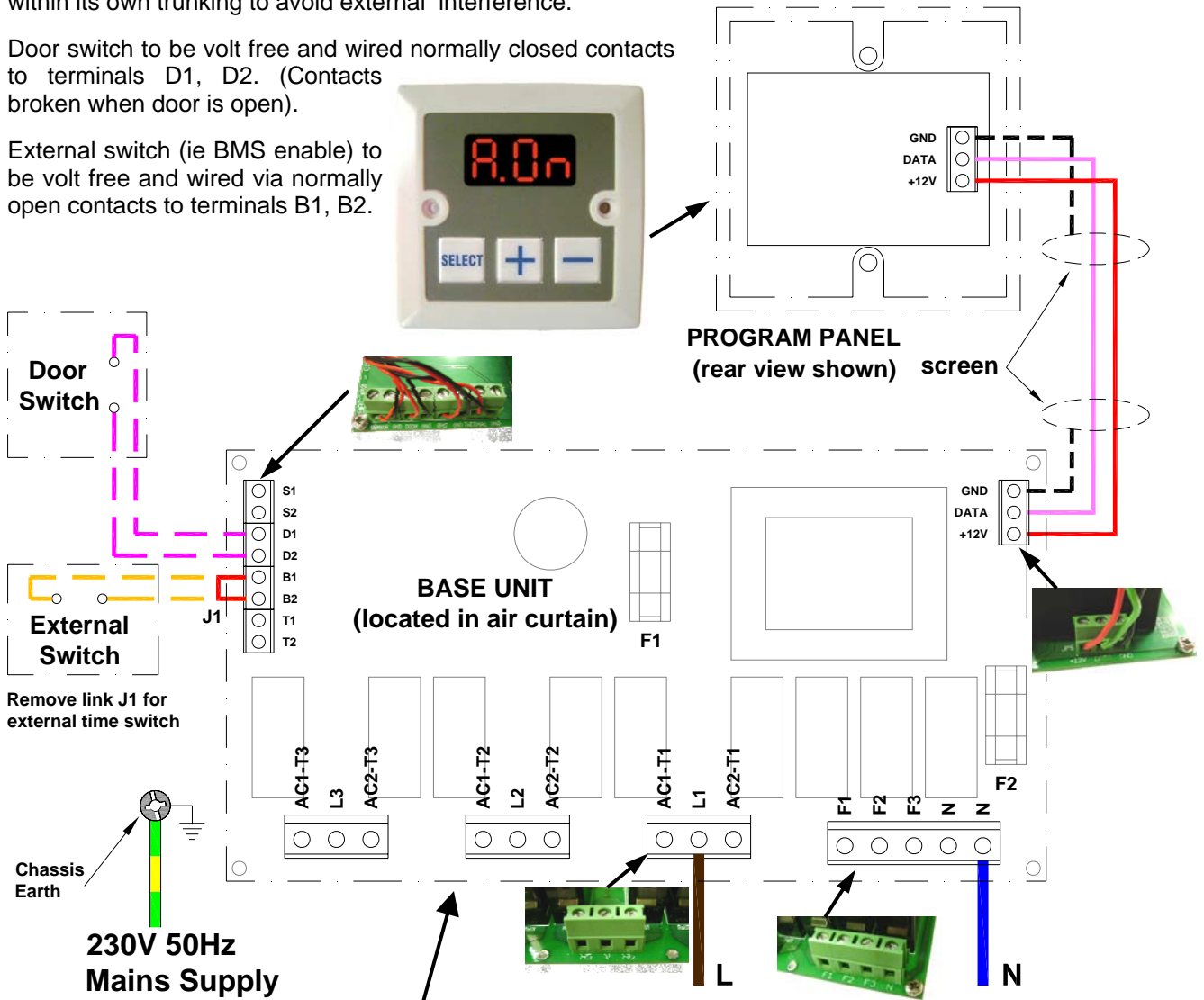

#### Protection

External circuit breaker with the appropriate rating should be installed for the protection of the installation.

Pcb Terminal	Description	Cable
N	Neutral	4mm <sup>2</sup> max
L	1 phase supply	4mm <sup>2</sup> max
+12V	Supply to remote unit	<b>Cable</b> 1.0mm <sup>2</sup> max
DATA	Data to remote unit	
GND(s)	0v Terminal	
D1, D2	Option door contact	
B1, B2	Option BMS switch	
Pcb Fuses		Rating (A)
F1		T2A (slow blow)
F2		T3.15A (slow blow)

### 4.5 Installer Wiring - LPHW

The program panel is connected to the base unit via a set of 3 way connectors marked "+12V", "DATA" and "GND". Interconnecting wiring is via Belden 9174 or equivalent cable as shown. **Max length 50m.**

It is recommended that this control cable is run separately within its own trunking to avoid external interference.

Door switch to be volt free and wired normally closed contacts to terminals D1, D2. (Contacts broken when door is open).

External switch (ie BMS enable) to be volt free and wired via normally open contacts to terminals B1, B2.

Optional internal/external sensor to be wired to terminals S1, S2.

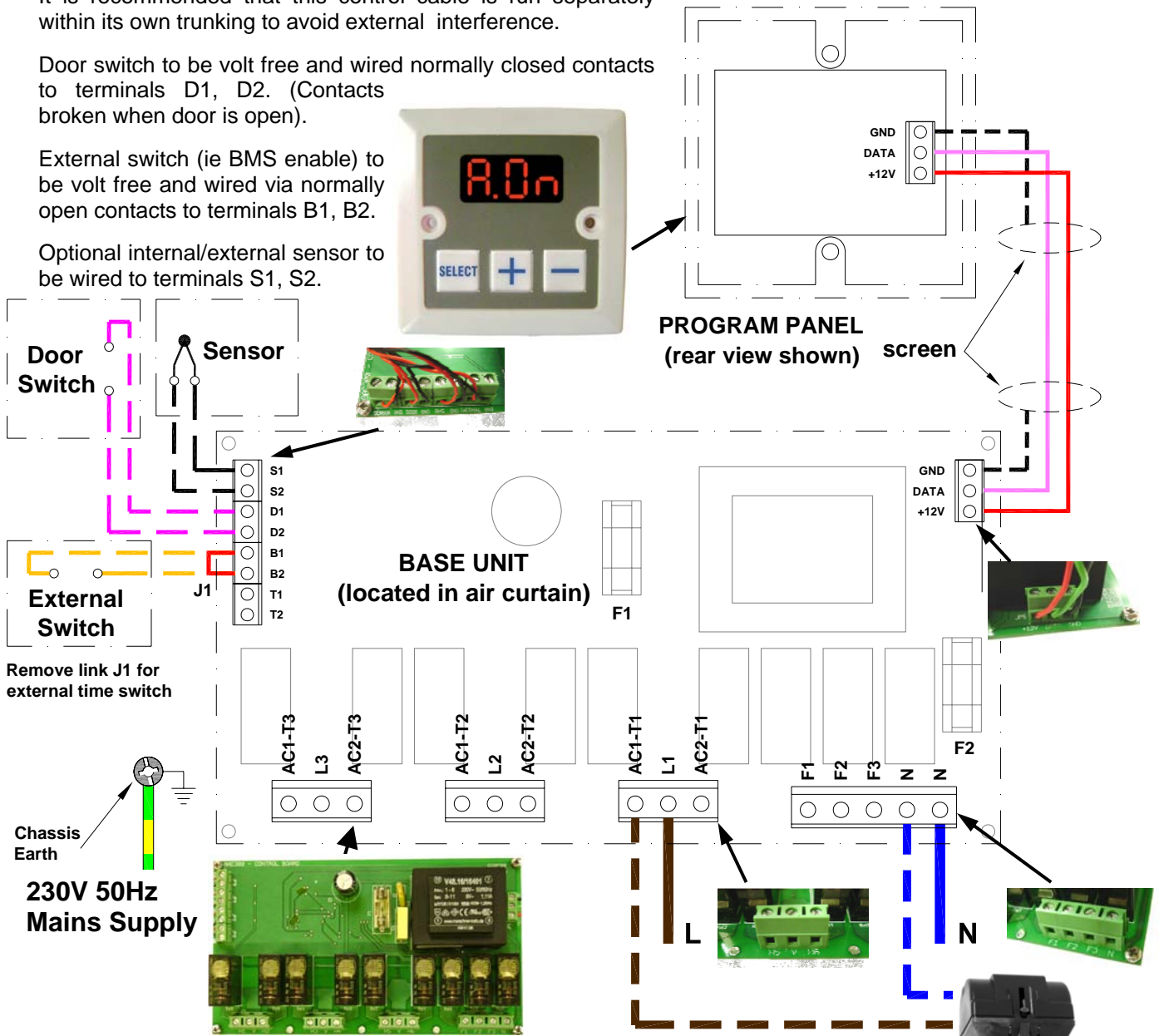

Terminal	Description	Cable
N	Neutral	4mm <sup>2</sup> max
L1	1 phase supply	4mm <sup>2</sup> max
Pcb Terminal	Description	Cable 1.0mm <sup>2</sup> max
12V	Supply to remote unit	
DATA	Data to remote unit	
GND(s)	0v Terminal	
D1, D2	Option door contact	
B1, B2	Option BMS switch	
S1, S2	Option internal/external sensor	
Pcb Fuses	Rating (A)	
F1	T2A (slow blow)	
F2	T3.15A (slow blow)	19

Optional 3 port valve to be wired to terminals AC1T1 and N.

#### Protection

External circuit breaker with the appropriate rating should be installed for the protection of the installation.

4.6 Factory Wiring - Electrically heated 6 & 9kW SINGLE PHASE ONLY

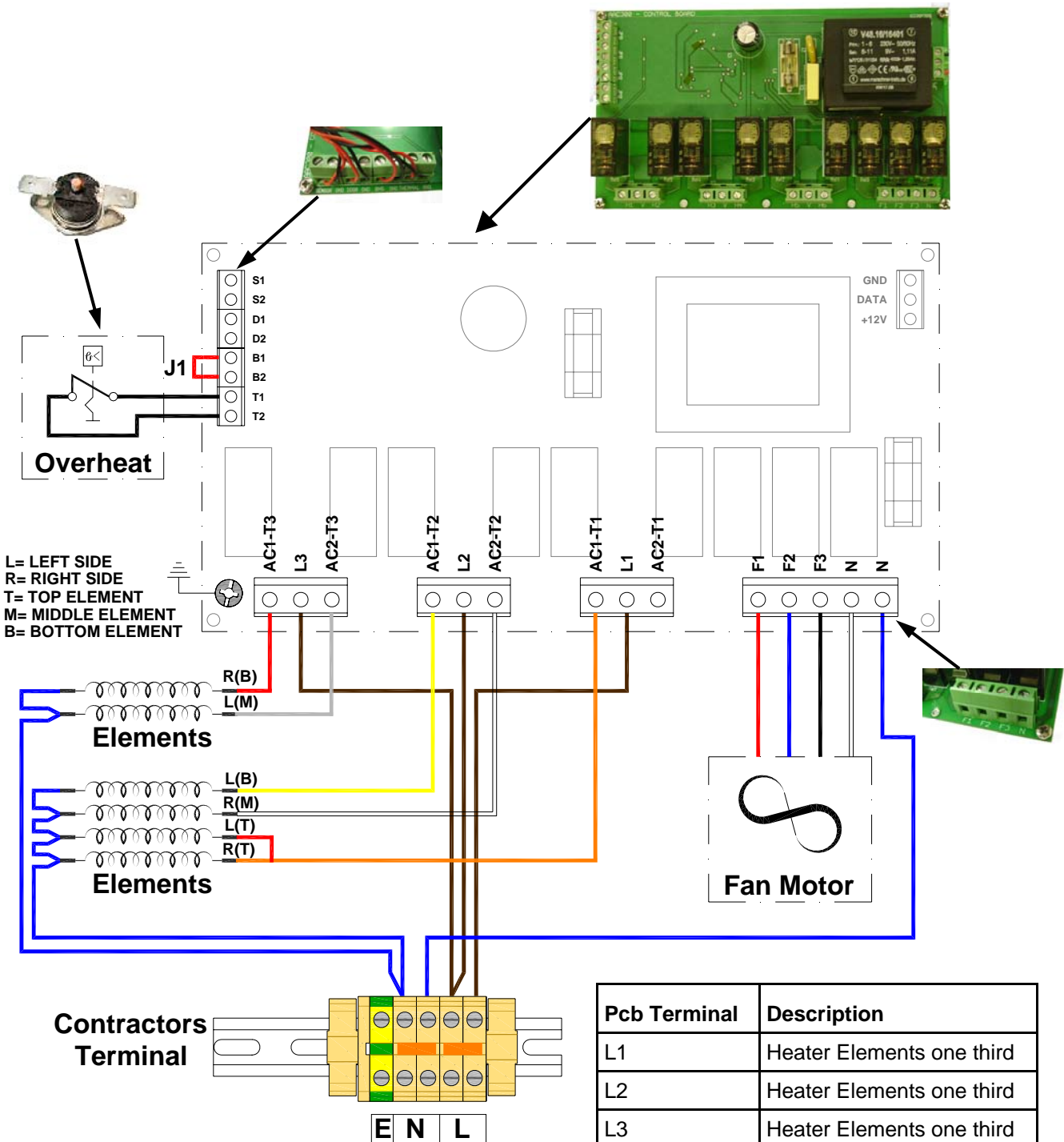

Pcb Terminal	Description
L1	Heater Elements one third
L2	Heater Elements one third
L3	Heater Elements one third
T1	Thermal Overheat trip
T2	Thermal Overheat trip
N	Neutrals
F1	Fan - low speed
F2	Fan - medium speed
F3	Fan - high speed
J1	Factory BMS link

The element output is connected to the right and left side of each terminal block marked "AC1-T1", "AC2-T1", AC1-T2", "AC2-T2", "AC1-T3" and "AC2-T3"

The fan output is connected to a 4 way connector marked "N", "F1", "F2" and "F3".

The thermal trip is connected to a 2 way connector marked "T1" & "T2"

## 4.7 Factory Wiring - Electrically heated 9 & 12kW THREE PHASE ONLY

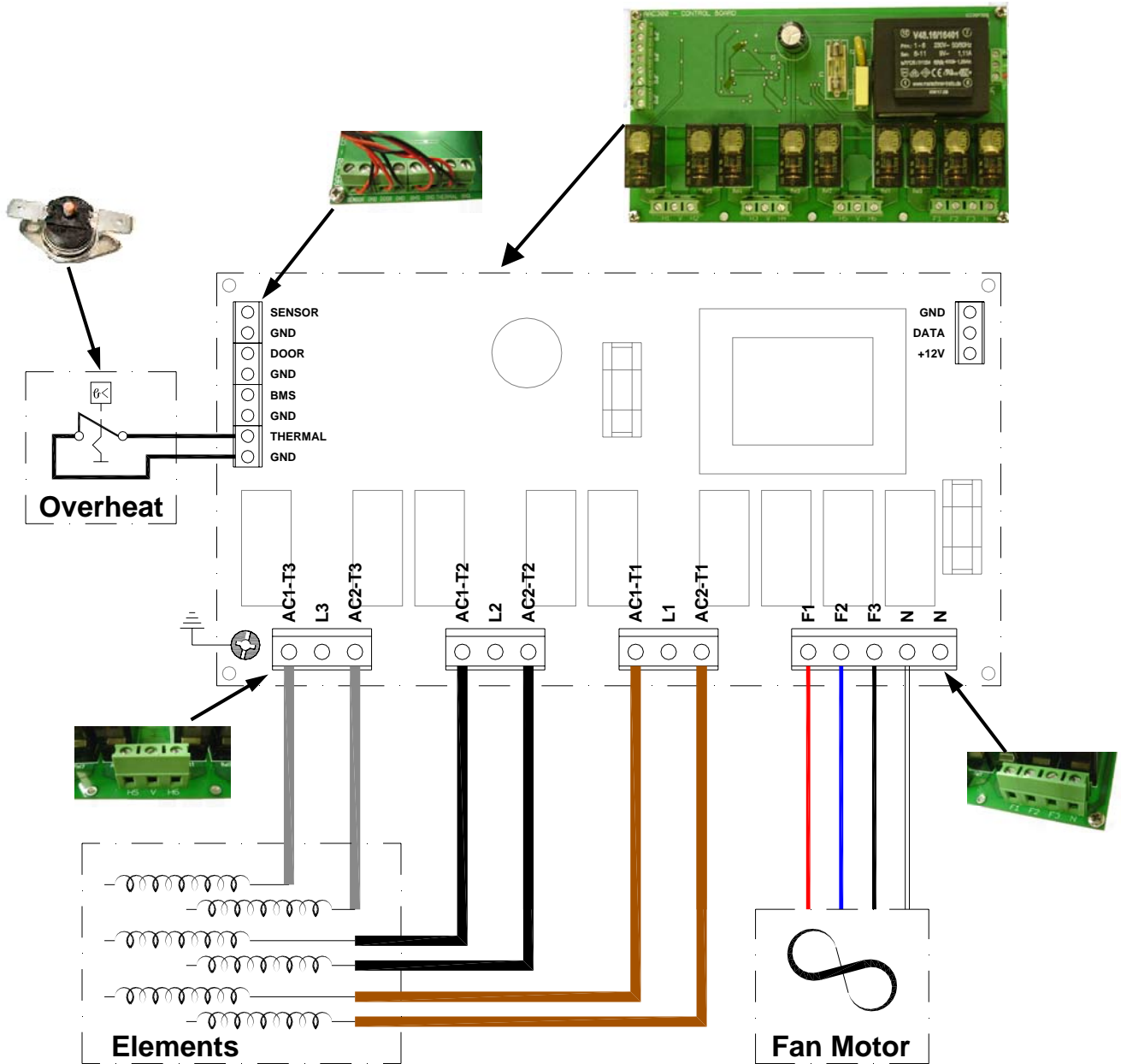

Pcb Terminal	Description
L1	Heater Elements phase 1
L2	Heater Elements phase 2
L3	Heater Elements phase 3
N	Neutral to fan
F1	Fan - low speed
F2	Fan - medium speed
F3	Fan - high speed
T1	Thermal Overheat trip
T2	Thermal Overheat trip
J1	Factory BMS link

The element output is connected to the right and left side of each terminal block marked "AC1-T1", "AC2-T1", "AC1-T2", "AC2-T2", "AC1-T3" and "AC2-T3"

The fan output is connected to a 4 way connector marked "N", "F1", "F2" and "F3".

The thermal trip is connected to a 2 way connector marked "T1" & "T2"

## 4.8 Factory Wiring - Electrically heated 18 & 24kW THREE PHASE ONLY

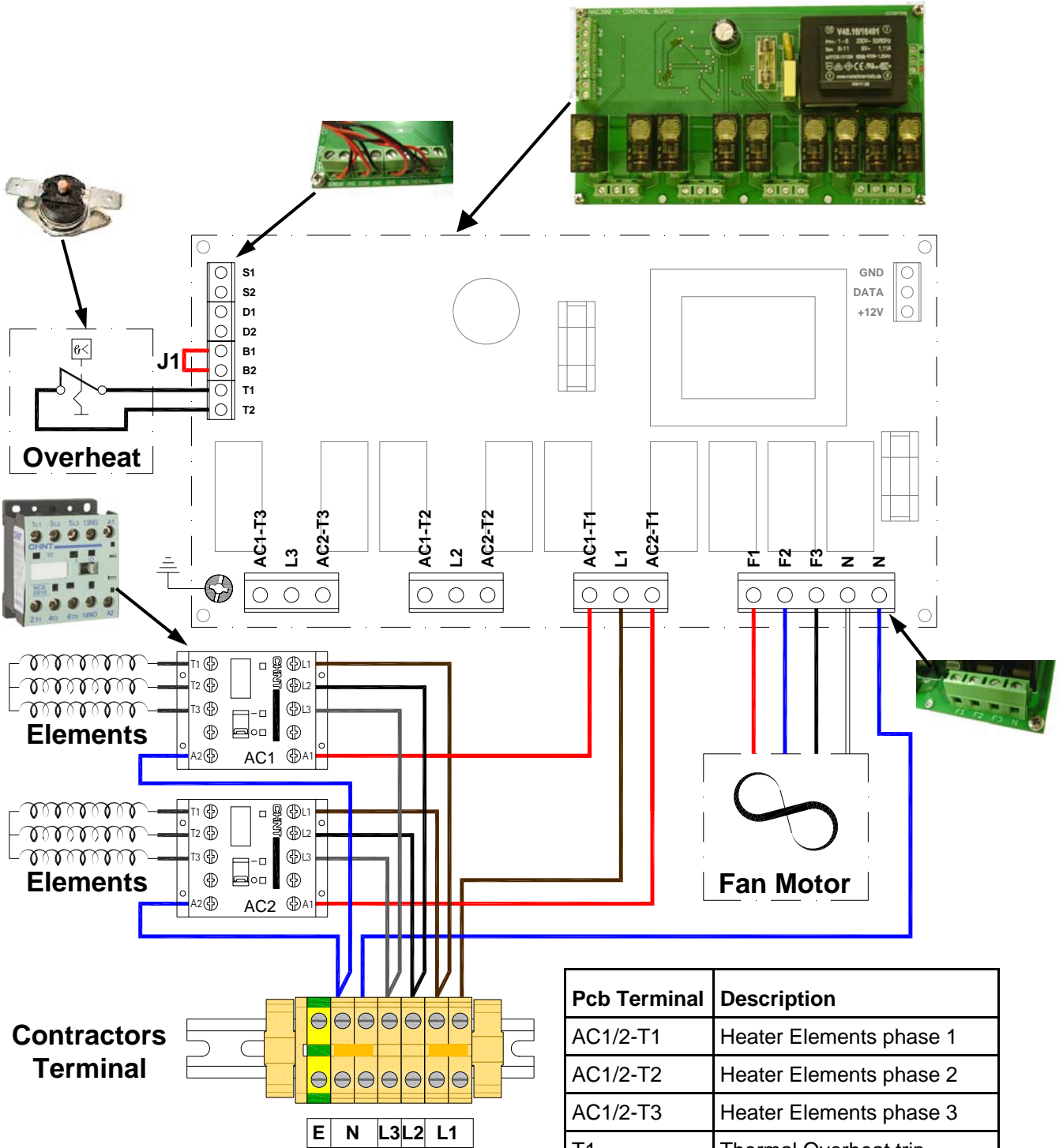

The element outputs are connected to contactors "AC1" and "AC2" on terminals T1, T2 and T3.

The fan output is connected to a 4 way connector marked "N", "F1", "F2" and "F3".

The thermal trip is connected to a 2 way connector marked "T1" & "T2"

## 4.9 Factory Wiring - Ambient

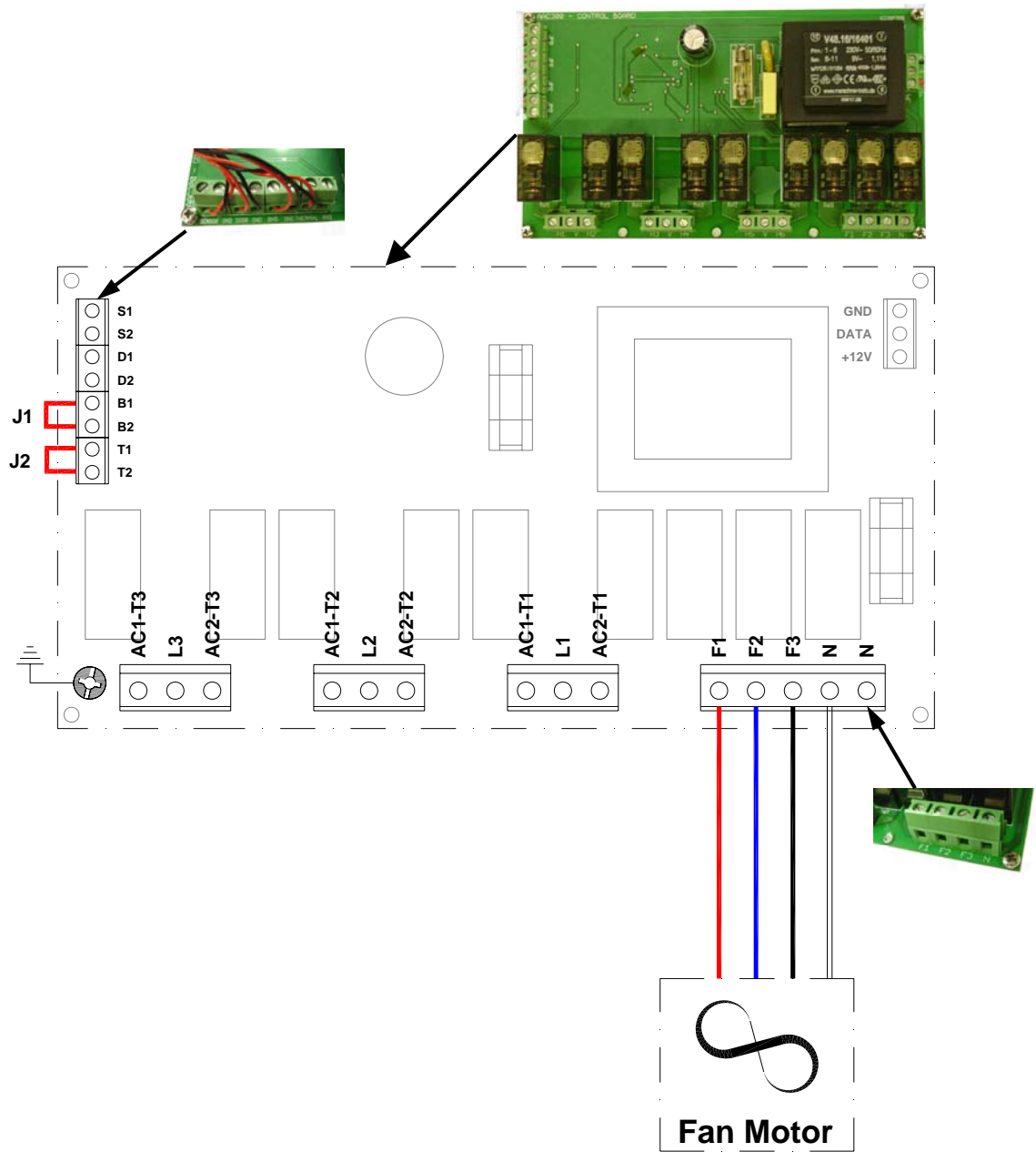

Pcb Terminal	Description
N	Neutral to fan
F1	Fan - low speed
F2	Fan - medium speed
F3	Fan - high speed
J1	Factory BMS link
J2	Factory thermal link

The fan output is connected to a 4 way connector marked "N", "F1", "F2" and "F3".

### 4.10 Factory Wiring - LPHW

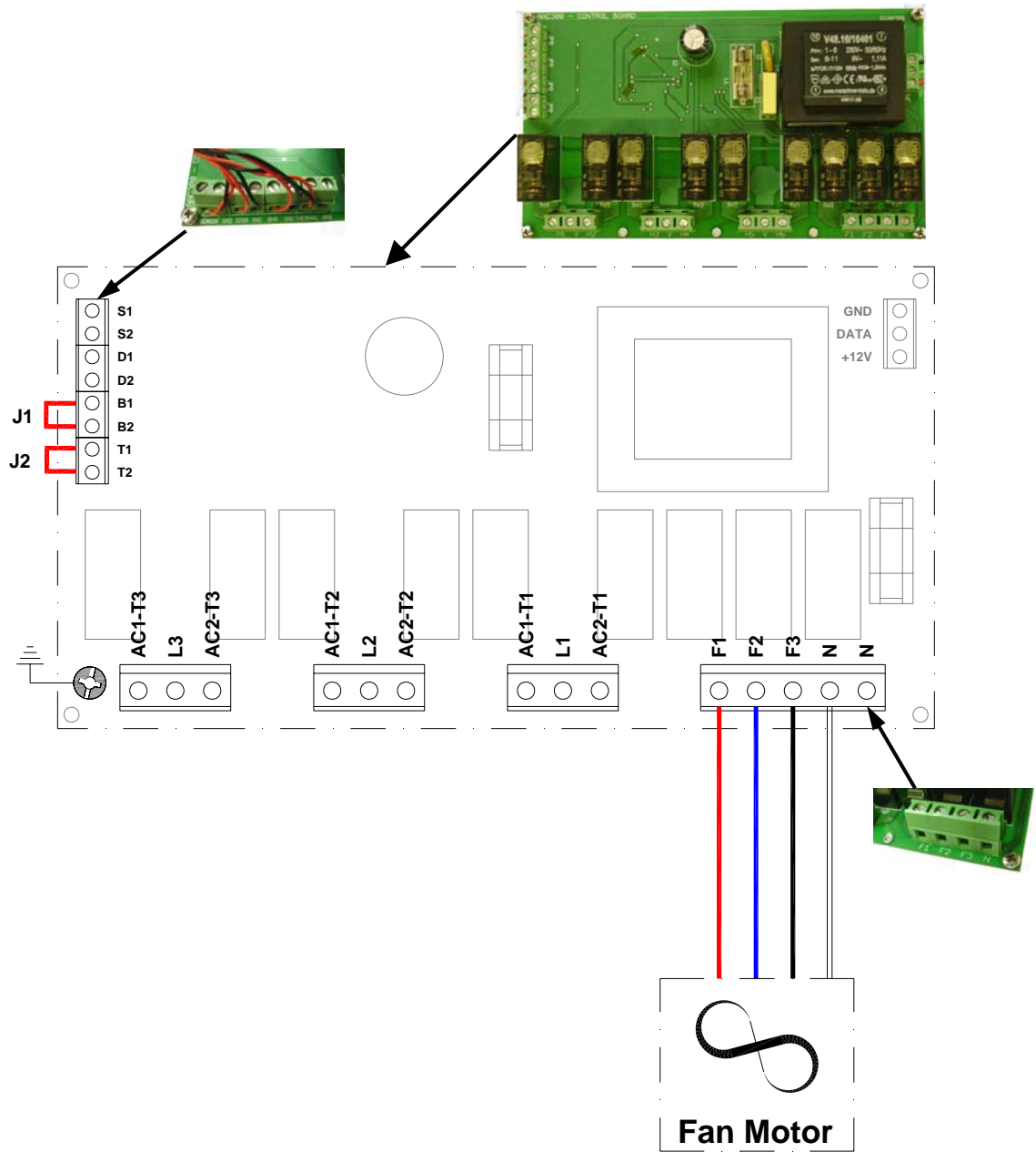

Pcb Terminal	Description
N	Neutral to fan
F1	Fan - low speed
F2	Fan - medium speed
F3	Fan - high speed
J1	Factory BMS link
J2	Factory thermal link

The fan output is connected to a 4 way connector marked "N", "F1", "F2" and "F3".

## 4.11 Network Wiring - Electronic controller

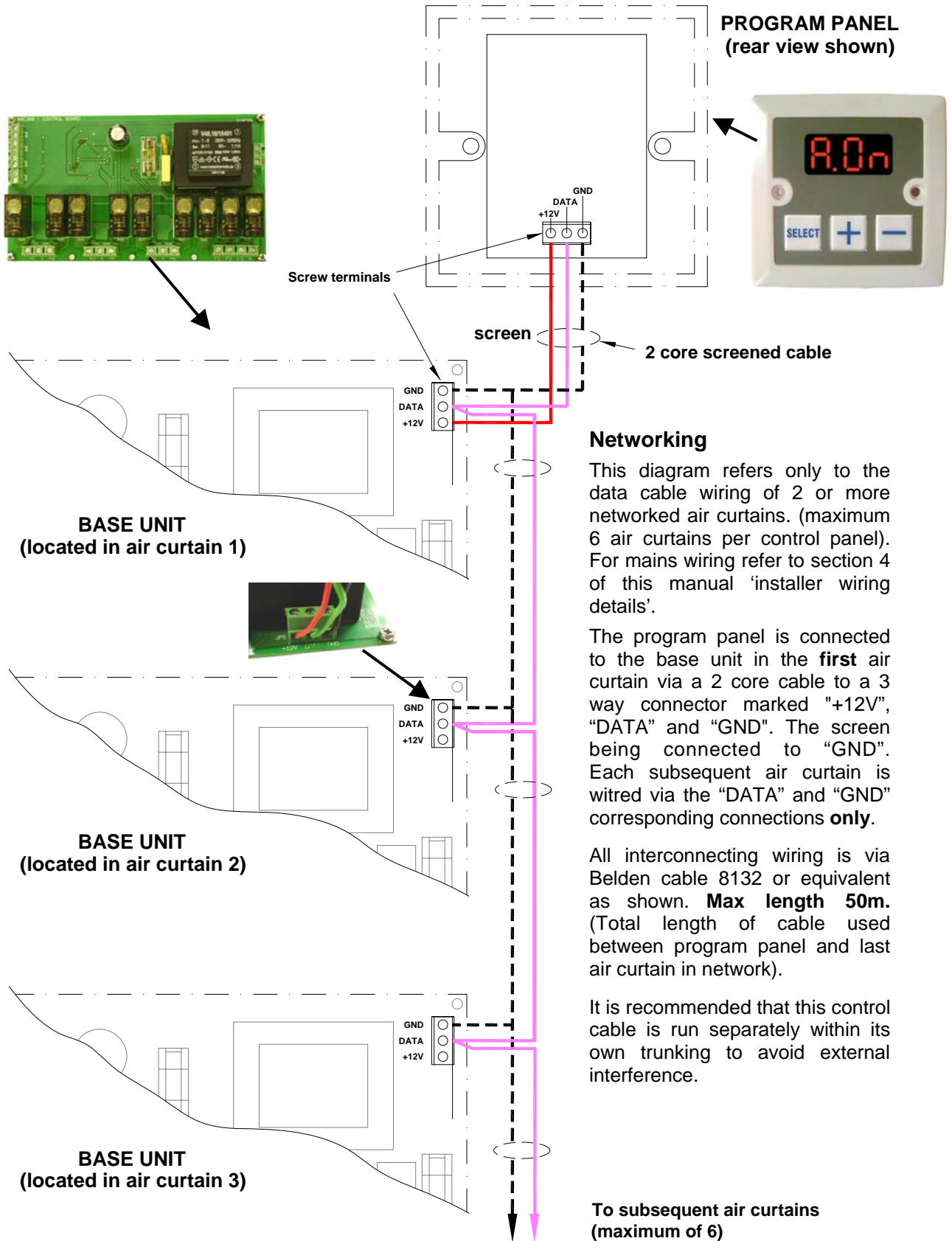

#### 4.12 Installer wiring diagram Electrically Heated with SmartElec control.

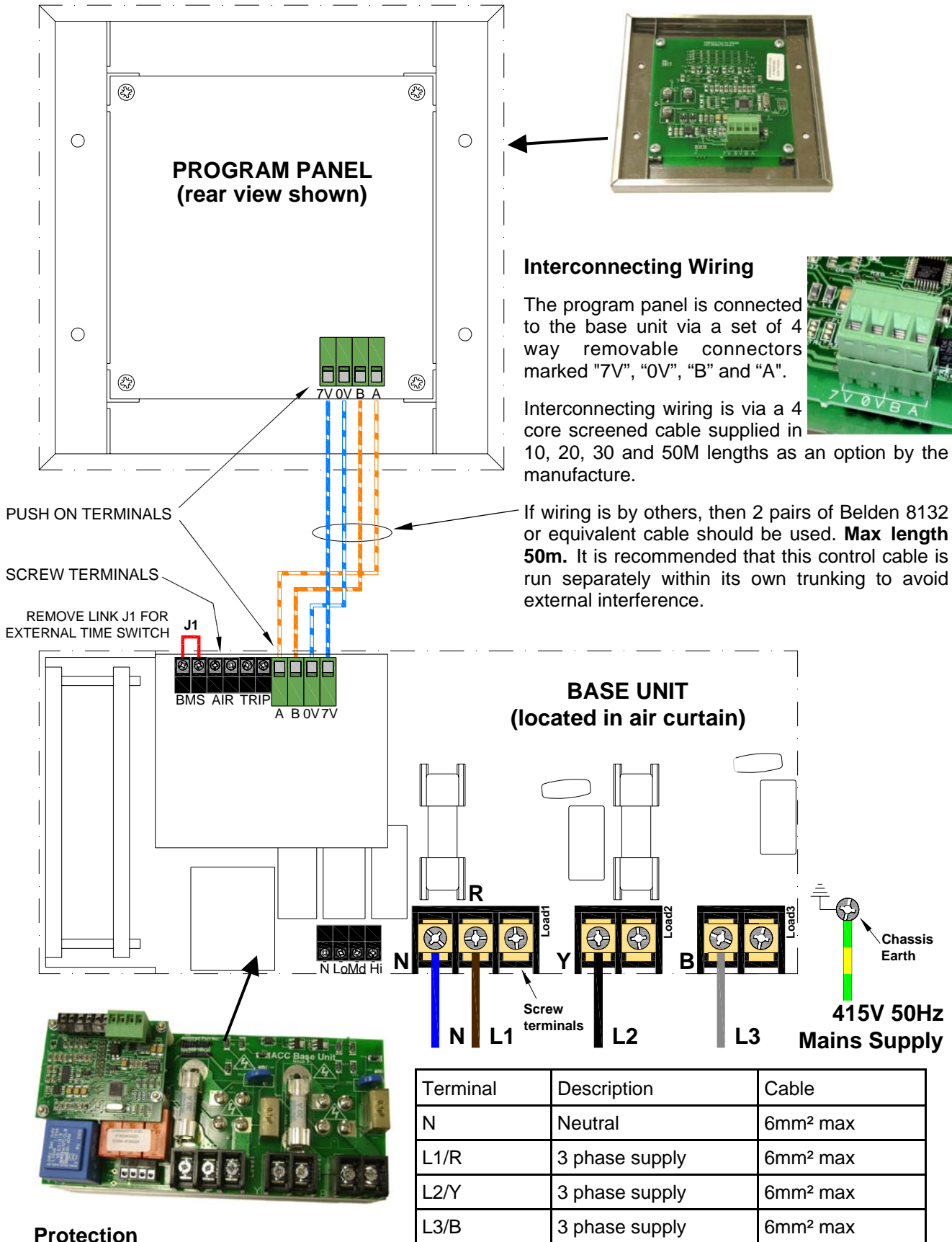

### 4.13 Factory Installed Wiring. Electrically Heated with SmartElec Control.

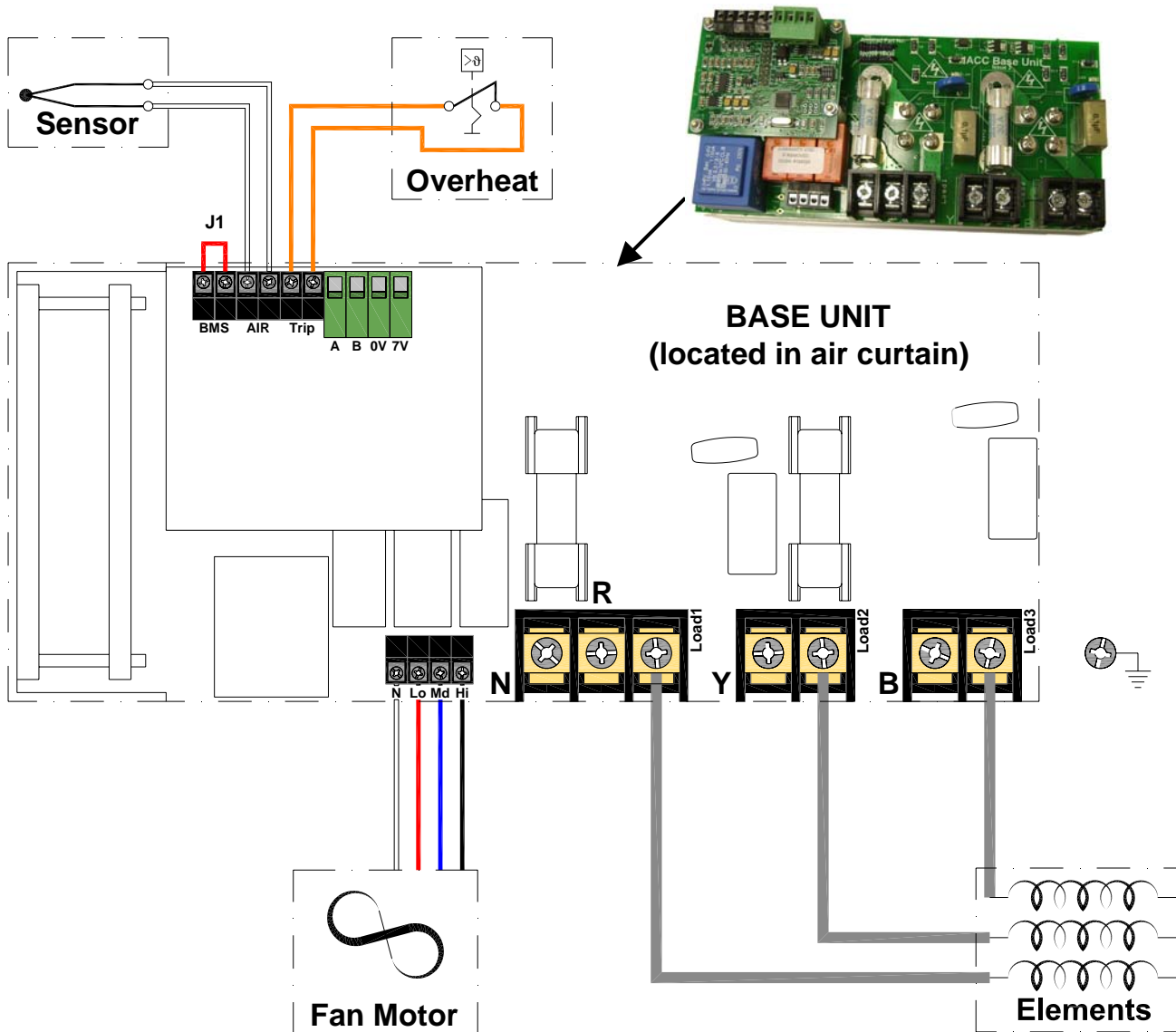

Terminal	Description
Load1	Heater phase 1
Load2	Heater phase 2
Load3	Heater phase 3
N	Neutral to fan
Lo	Fan - low speed
Md	Fan - medium speed
Hi	Fan - high speed
AIR	Air sensor (non-polarised)
AIR	Air sensor (non-polarised)
Trip	Ext thermal trip, n.c. (volt-free)
Trip	Ext thermal trip, n.c. (volt-free)
BMS	BMS off (volt -free)
BMS	BMS off (volt -free)

The heater output is connected to the right hand side of each terminal block marked "Load1", "Load2" and "Load3".



The fan output is connected to a 4 way connector marked "N", "Lo", "Md" and "Hi".

The sensor input (air sensor) is connected to a 2 way connector marked "AIR" on the base unit. The sensor is not polarity sensitive.

The external thermal trip (volt-free contact) is connected to a 2 way connector marked "Trip". The connection is not polarity sensitive.

After removing link J1, the BMS pair can be used for external time control via a pair of volt free contacts.

4.14 Network Wiring Electrically Heated SmartElec Control.

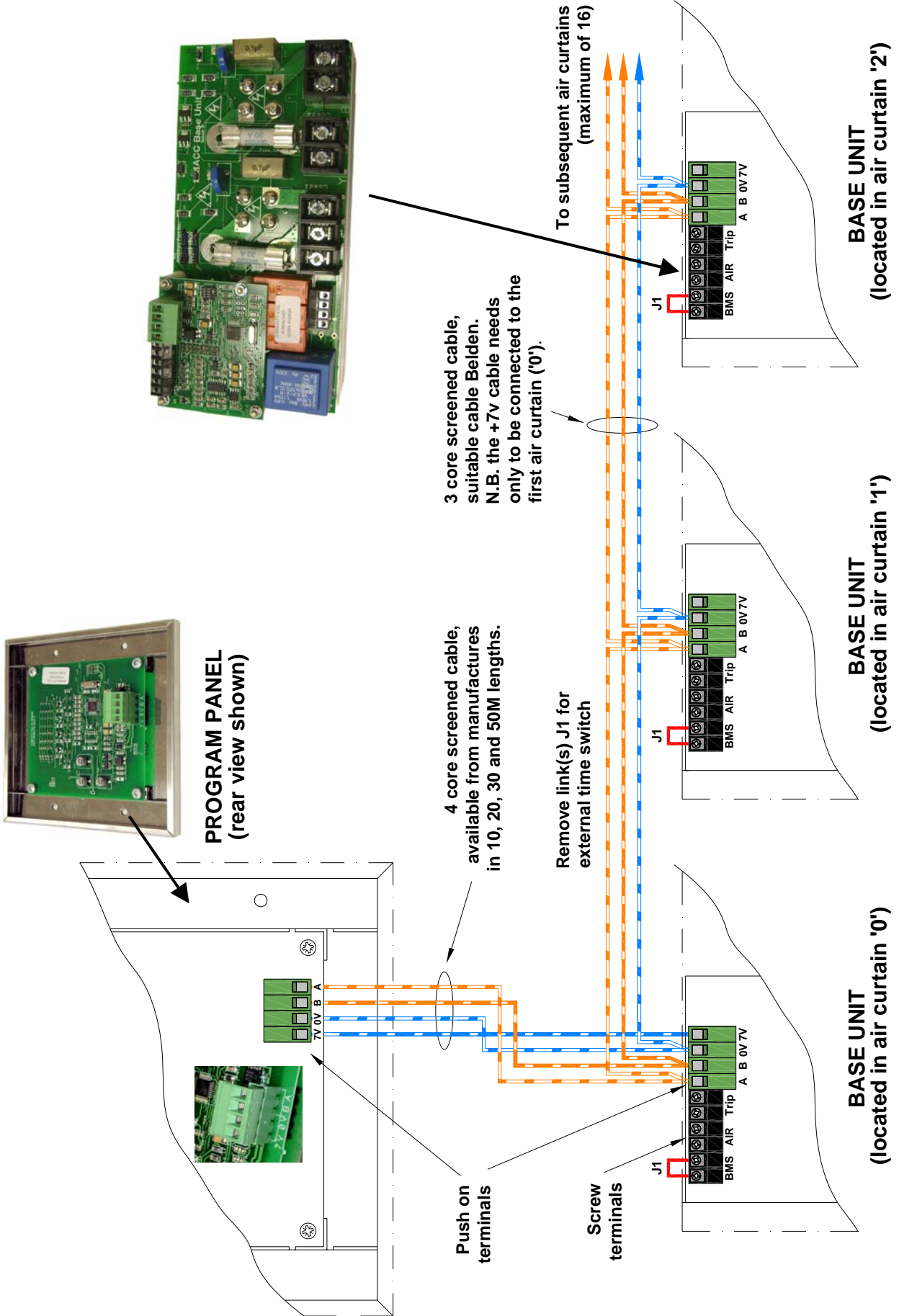

## 5. Installation Details.

### 5.1 Mounting

Airbloc units should be installed horizontally directly over the door opening. It is recommended that the air curtain is installed on the inside of the building, within the open room space against a wall or ceiling.

Care must be taken to allow complete free air movement into the inlet grilles of the unit to ensure correct working operation of the air curtain. The discharge opening should be as close to the top of the door as possible and to cover the entire door width.

Units can be mounted adjacent to each other to cover the full door opening across wider entrances.

These units are designed for surface mounting and should not be placed into a ceiling void, due to possible obstruction of airflow and difficulty in routine cleaning and maintenance.

### 5.2 Electrical Supply.

These units are suitable for connection to a 415 Volt, 50Hz 3 phase and neutral supply for Electrically heated 9-24kW models or 230/240 Volt 50 Hz single phase supply for Electrically heated 6kW, 9kW, Ambient and LPHW models.

Electrically heated models consume 6kW and 9kW at 230 volts and 9kW, 12kW, 18kW & 24kW at 415 Volts when switched to the full heat position depending on their model and capacity size .

The appliance shall be connected to the supply via an appropriate switched fused double pole isolator having a contact separation of greater than 3mm. Test for correct operation and refit the cover.

For connection to the mains supply it will be necessary to remove the outer cover from the unit. After removing the cover you will note the mains terminal block and it will be necessary to connect the mains supply and the lead from the remote switch box prior to refitting the cover. Wire in accordance to diagrams in section 4.1 to 4.5

For optional SmartElec controller, wire as shown in diagrams 4.12 to 4.14

 For safety reasons, a sound earth connection must always be made to the unit before it is put to use. The unit should be wired in accordance with IEE Regulations for the Electrical Equipment of Buildings.

### 5.3 Installation.

It is the sole responsibility of the installer to ensure that the points of attachment to the building are sound. Consultation with the consultant/architect or owner of the building is recommended to ensure that a sound, mechanically stable installation is achieved.

All attachments must be capable of supporting the weight of the product detailed in Section 3.

#### Step 1



Remove all packaging. Remove decorative cover. Undo screws securing the outlet. (not Chassis version)

*Note All outer metal surfaces are covered by a protective plastic film, which must be removed before final fixing and operating of the unit.*

#### Step 2



Carefully remove the air curtain front cover by removing four screws (not Chassis version)

### Step 3

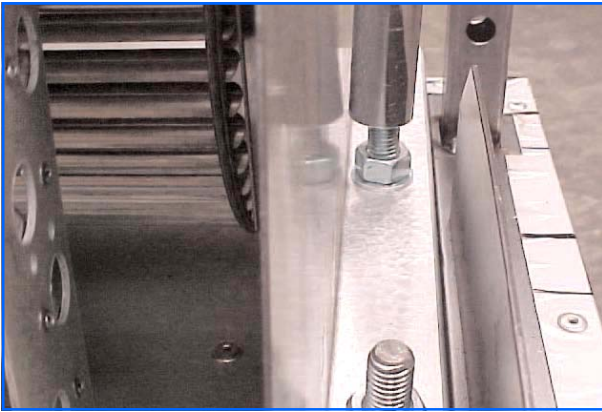

It is recommended that the chassis is removed from the back box to avoid having to support the weight of the product during installation.

To separate the chassis from the back box undo and remove the nuts shown and lift the chassis away from the back box.

The product can be installed using either M12 drop rods or fastened direct to the wall using appropriate sized fixings suitable for the wall surface and the weight of the product.

### Step 4



To wall mount the product, position the back box against the wall at the desired mounting height and mark through the holes in the back box brackets to enable the wall to be drilled for the appropriate fixings.

### Step 5

Drill the wall then fix the backbox in position. Lift the chassis (using lifting gear if necessary) onto the studs on the back box brackets. Refit and tighten the nuts.

### Step 6



Holes are provided in the back box for the feed cable to enter the case. Choose the appropriate hole top rear to suit the installation.

Fit suitable cable gland for size of cable.

### Step 7



To install the product using M12 drop rods follow instructions from step 4. If the decorative tube is to be used, fit this over the drop rod, then pass the drop rod through the back box brackets.

### Step 8

Adjust the product to the required height and ensure that it is fitted level using a spirit level across the back box as required.

Tighten the lock nuts and re-assemble in reverse order. Adjust outlet to required angle to give desired performance, and tighten outlet screws.

### 5.4 Installation details - AC-ACR-PANEL programmer

The Electronic base unit is pre-installed inside the air curtain. All the external electrical connections are via screw terminals onto this base unit.

The program keypad is installed on a separate facia plate and connected to a surface mounted back box in a suitable location. Please see fig 5.

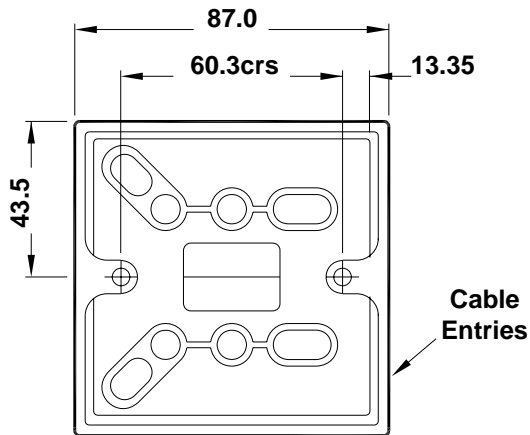

Fig. 5. Surface mount location holes.

Alternatively, the program panel can be flush wall mounted with the addition of a suitable conduit box MK part number 861 ZIC or equivalent.

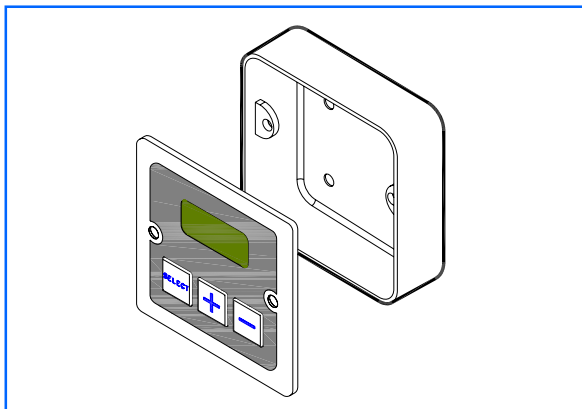

Fig. 6. Alternative conduit box

The distance between the base unit and the program panel can be up to 50m maximum.

### 5.5 Installation details - Option SmartElec Controller

The SmartElec base unit is pre-installed inside the air curtain. All the external electrical connections are via screw terminals onto this base unit.

The SmartElec program panel is installed in a separate housing and connected to a surface mounted back box in a suitable location. Please see fig 7.

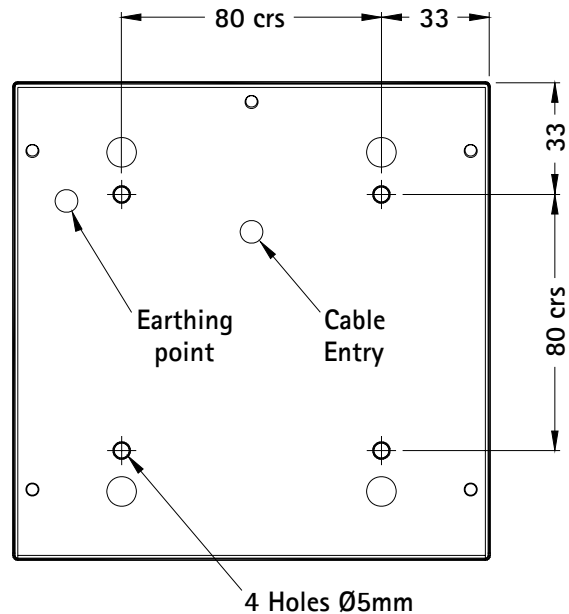

Fig. 7. Surface mount location holes.

Alternatively, the program panel can be flush wall mounted with the addition of a suitable conduit box MK part number 893 ALM or equivalent.

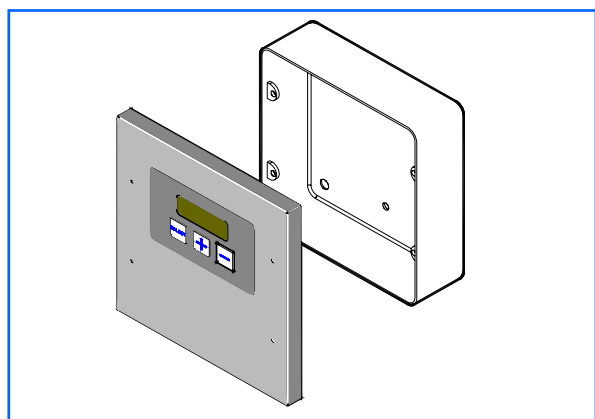

Fig. 8. Alternative conduit box

The distance between the base unit and the program panel can be up to 50m maximum.

## 5.6 Installation details - LPHW Only

Installation of the LPHW unit is as described earlier. Once situated, access to the heating coil and controller base unit is via removal of the case front.

The LPHW copper tubing connections are as shown in fig.9 below and are 15mm outside diameter. Ensure correct water seal fittings are used. We recommend the use of a suitable gate valve to ease any maintenance.

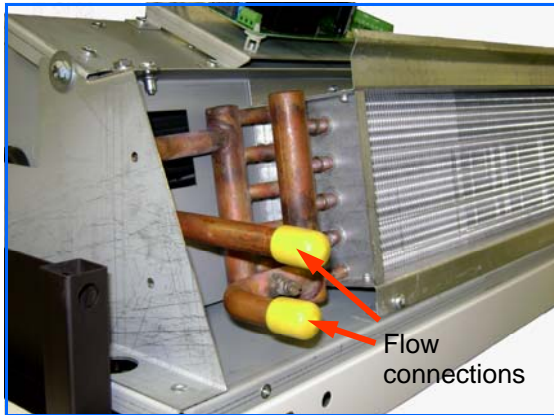
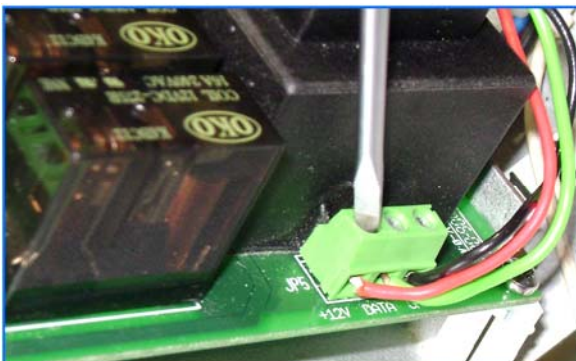
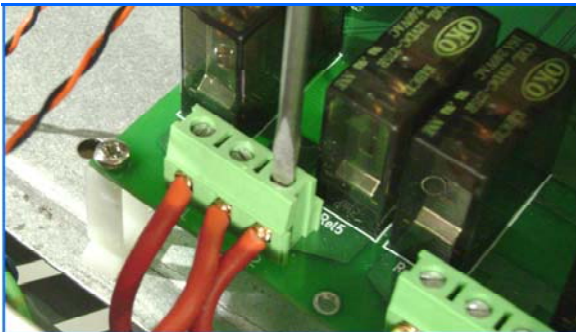

Fig. 9. LPHW connections.

## 5.7 Installation wiring

With case removed, connect the electrical supply and program panel interconnecting wiring to the relevant terminals on the controller base unit (See wiring diagrams section 4)



## 6. Optional Light Box/Down lighters.

### 6.1 Dimensions.

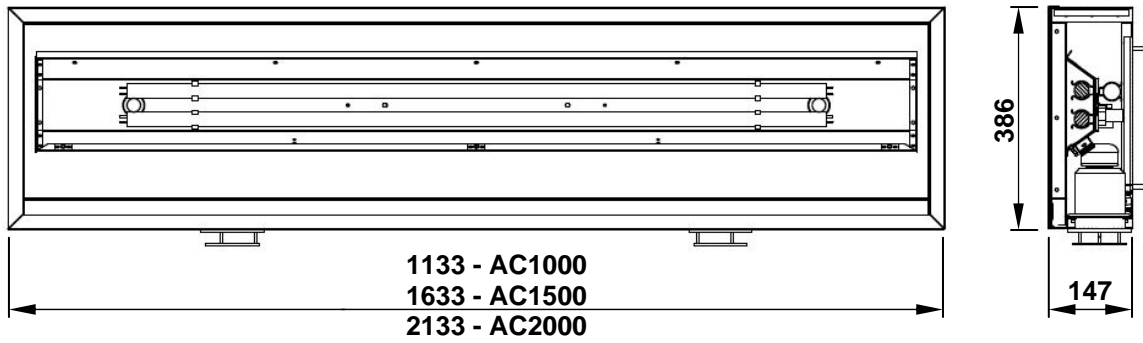

### 6.2 Installation.

To enable the light box to be attached to the air curtain, there are 4 studs/nuts on the back of the light box.



Ensure that the power is isolated from the air curtain and remove the decorative case from the air curtain.

Note at the side of the air curtain fixing brackets that there are holes of the correct size and centres to attach the light box to the air curtain.



Remove the nuts from the studs. Lift and support the light box (using suitable equipment as

necessary) and put the studs through the mating holes on the air curtain.

Note:- there is a cable coming out of the light box to enable the lights to be powered. Take care when fitting and pass the cable thro the mating hole in the air curtain.



Continue to support the light box and using a suitable socket tighten the nuts to make the air curtain and light box a complete assembly.

There are M10 cage nuts in the top of the light box that allow drop rods to be used to provide support to the complete assembly.



Decorative extrusions are available from the manufacturer to cover the drop rod. Please note that these extrusions need to be fitted at the time of installation.

### 6.3 Wiring.

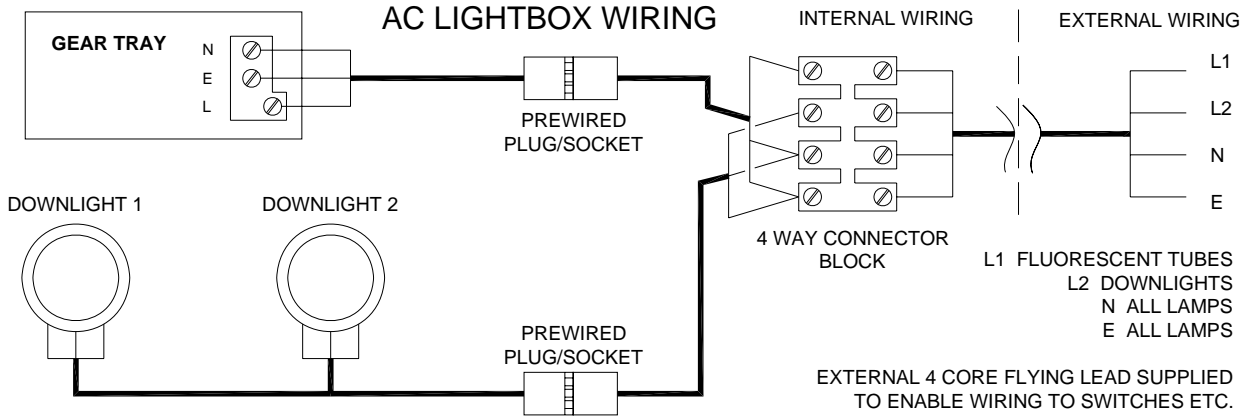

The flying lead from the light box needs to be routed to the mains terminal block on the air curtain and the L, N, & Earth wires connected appropriately.

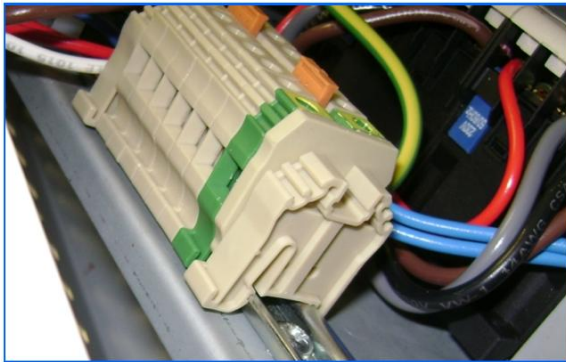

### 6.4 Rear Panel & Sign Options.

Provided as standard with the product is a rear panel.

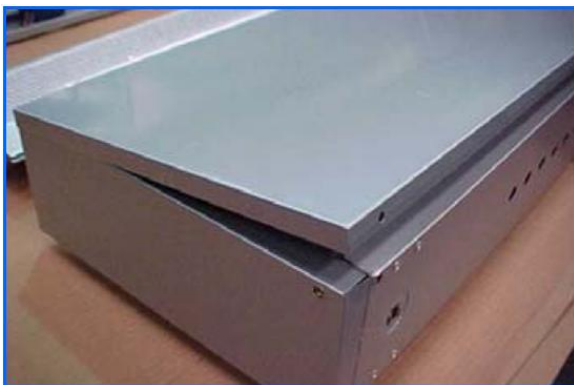

Behind the rear panel are the fluorescent tubes that can be used to illuminate an acrylic sign with appropriate branding for the premises (supplied by end user).

Please note that the fluorescent tube connectors are detached at our factory, and these need to be re-connected on-site if the optional acrylic sign is used.

If an acrylic branding sign is required, then remove the rear panel and use the 2 off L shaped frames provided to fasten the sign in place.

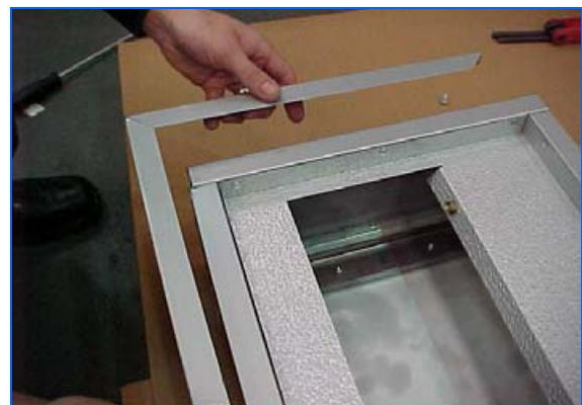

## 7. Optional Fire Exit Luminaire.



### 7.1 General

All emergency lighting luminaires supplied are designed and manufactured to conform with relevant British Standard specifications.

It is important that the user does not modify any luminaire or use them for a purpose, or in an environment for which the luminaires are not designed.

Any modifications may render the luminaires unsafe and will invalidate the warranty and CE compliance of the product.

All luminaires unless otherwise stated are designed for direct connection to a standard mains supply as so indicated on the luminaire. All switching etc. shall comply with BS 5266 part 1 and the latest IEE regulations. Luminaires shall NOT be connected to, or be controlled by an energy management system.

Maintained luminaires should NOT be switched ON/OFF in excess of twice in any 24 hour period, as this can lead to blacking of the lamp and therefore reduce the effectiveness of the luminaire in the case of an emergency.

Installation must only be carried out by a competent electrician and in accordance with the installation and commissioning instructions.

Installation must be carried out in accordance with:

- i) Regulations for Electrical Installation, published by the Institute of Electrical Engineers.
- ii) Requirements of BS 5266 part 1.

Surge suppressers may be required at the point of connection to the supply wiring when installing luminaires to MICC.

Insulation testing should be in accordance with the latest IEE regulations and should not exceed 500V DC between Live and Neutral connected together and Earth.

### 7.2 Remote switching (Maintained)

This facility enables the fluorescent tube to be switched off when the maintained light is not required.

This facility does not affect the operation of the unit in emergency mode should a mains failure occur. When the switched live is energised, the unit will operate in the maintained mode with the tube energised via the mains supply. When the live is de-energised, the luminaire will operate in the non-maintained mode. If this facility is not required, simply linking the switched and unswitched terminals together will cause the luminaire to operate in maintained/sustained mode at all times.

### 7.3 Commissioning/Testing

The unit should be left on charge for a minimum of 24 hours before being tested for its rated duration. After connecting the mains supply check that:

- i) The Red Led is illuminated. This indicates that the battery is being charged correctly.
- ii) The luminaire will energise the lamp under emergency conditions, by removing the mains supply.

b. Routine testing should be carried out in accordance with the instructions as indicated on the test record card. (Which is supplied with each product).

## 7.4 Specification

Lumens Output  
 8W 90 Lumens (3 cell)  
 Battery Data: High temperature NiCd D cell  
 1.2V per cell: 4 Ampere hour rating  
 Input Voltage: 230-240V AC 50Hz

! *Note Lighting levels are only provided to allow checking of correct operation, and determination of correct lighting levels on an escape route can only be made with full photometric data.*

! **BEFORE OBTAINING ACCESS TO TERMINALS, ALL SUPPLY CIRCUITS MUST BE DISCONNECTED.**

! *This fitting must be electrically earthed.*

Confirm the installation requirements by checking the data provided (especially the AC supply and mode of operation required). Any installation must only be carried out by a competent personnel.

### 7.4.1 Non maintained

A luminaire in which the lamp is lit only under emergency conditions.

### 7.4.2 Maintained

A luminaire in which the lamp is lit either via a separate switched supply or under emergency conditions.

## 7.5 Installation

Connect the mains supplies to the terminal block provided, see connection diagrams. Refer to remote switching instructions for further details.

The battery connections are via faston connectors from the PCB to the battery pack. The battery pack should be marked with the date of installation/commissioning.

Refer to General, Operating and Test Instructions for further details.

*Note When the live is de-energised, the luminaire will operate in the non-maintained mode. If this facility is not required, simply linking the switched and unswitched terminals together will cause the luminaire to operate in maintained mode at all times.*

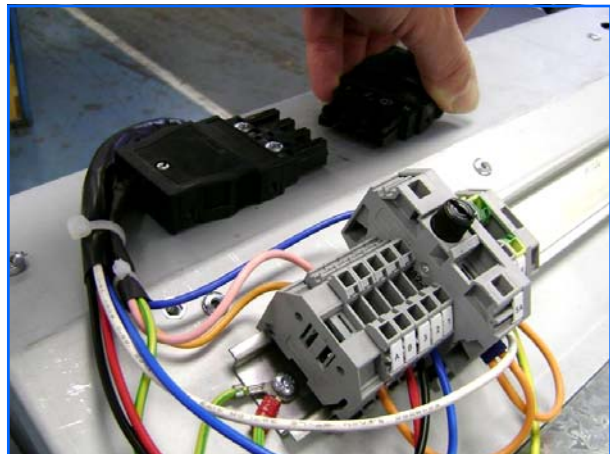

## 7.6 Wiring Diagram

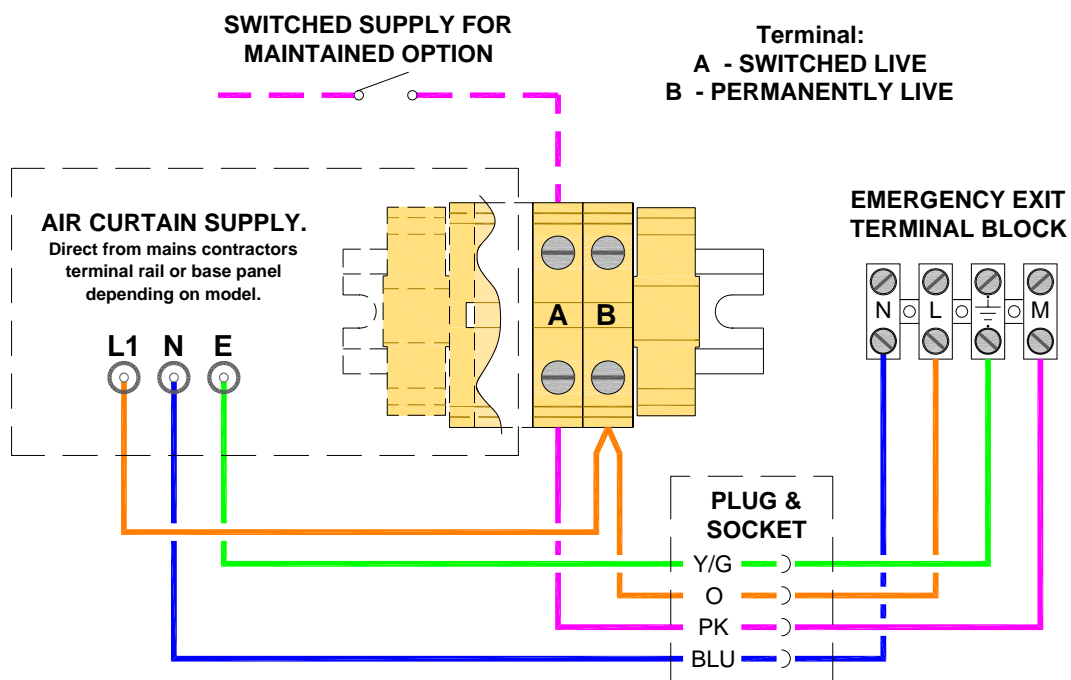

## 8. Servicing & Maintenance.

**! ALWAYS ENSURE THAT THE MAIN EXTERNAL ELECTRICITY SUPPLY IS SWITCHED OFF BEFORE COMMENCING ANY MAINTENANCE ON THIS HEATER.**

To obtain the best results from the heater, it is essential to avoid the accumulation of dust and dirt within the unit on the air inlet and discharge grilles. For this reason regular cleaning is necessary, paying particular attention to the removal of dirt build up on the rotor blades.

Cleaning of the fan is best carried out with a soft brush.

A single drop of light oil should be applied to the motor bearing from time to time.

The product should be serviced annually. Servicing shall be undertaken by a competent person. Airbloc offer a service facility, call 01384 489700.

### Step 1



Undo screws securing the grille.

### Step 2



Adjust the grille by turning the screw inside with an allen key.

### Step 3

Remove 4 screws securing the top of the case and remove (not Chassis version)



### Step 4

Slacken two bolts on both ends.



Remove three bolts securing the access plate.

Carefully hinge down the access plate.  
*Note Take the weight as access plate swings down.*

### Step 5





With a soft brush clean away any dust from the motor and elements.

Check all connections and components for soundness or signs of deterioration and replace as necessary.

Re-assemble and test.

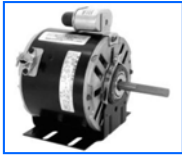

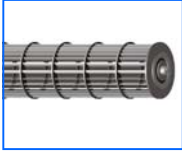
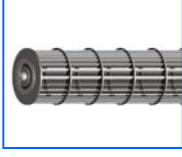
## 9. Spare parts

### 9.1 General

	Description	AC1000SE06/ AC1000SE09/ AC1000HE12/ AC1000SW9/ AC1000HW12/ AC1000SA/ AC1000HA	AC1500SE6/ AC1500SE12/ AC1500HE18/ AC1000SW12/ AC1000HW18/ AC1000SA/ AC1000HA	AC2000SE9/ AC2000SE18/ AC2000HE24/ AC2000SW18/ AC2000HW24/ AC2000SA/ AC2000HA
	Motor		100535	
	Contactor (where required)		900078	
	Rotor Left Hand	100539	100540	100541
	Rotor Right Hand	100536	100537	100538
	Thermal cut out (where required)		900001	



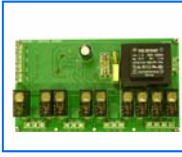

### 9.2 AC-ACR-PANEL controller

! Due to the nature of its construction, it is not advisable to repair damaged electronic components on either the AC-ACR base unit or AC-ACR-PANEL programmer

	Program Keypad		AC-ACR-PANEL	
	Base Unit		AC-ACR-PCB	
	Outside Air Sensor		SC-OS	

### 9.3 SmartElec controller

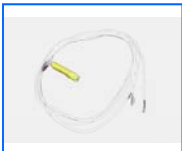
! Due to the nature of it's construction, it is not advisable to repair damaged electronic components on either the SmartElec base unit or Program panel.

	Description	AC1000SE09/ AC10000HE12	AC1500SE12/ AC15000HE18	AC2000SE18/ AC20000HE24
	Program Panel		102609	
	Panel P.C.B		900306	
	Base Unit		900397	900397 - 18kW 900310 - 24kW
	Heat Sensor		900329	
	Fuse	900326	900326 - 12kW 900327 - 18kW	900327 - 18kW 900328 - 24kW
	Cooling Fan		n/a	900330 - 24kW

### 9.4 Heating mediums

Element assembly



Rating	6kW	9kW	12kW	18kW	24kW
SE 1Pha	103713/103714	107819	-	-	-
Length	1.0m/1.5m	2.0m	-	-	-
SE 3Pha	-	100840	100841	100842	-
Length	-	1.0m	1.5m	2.0m	-
HE 3Pha	-	-	100526	100527	100528
Length	-	-	1.0m	1.5m	2.0m

Coil LPHW only



Rating	9kW	12kW	18kW	24kW
SE	101279	101280	101281	-
Length	1.0m	1.5m	2.0m	-
HE	-	100989	100990	100991
Length	-	1.0m	1.5m	2.0m

# 10. Fault Finding.

## 10.1 General

If the air curtain does not operate after running through the detail provided in Section 6, then a suitably competent service engineer should be called to identify the nature of the fault.

*Note The manufacturer operates a service function from the address provided in these instructions.*

All Air Curtains are fitted with fuse protection and motor thermal protection.

Other faults in relation to the element, motor and wiring should be identified using conventional fault finding techniques.

In the event that electrical components are replaced, please ensure that electrical safety checks in accordance with the regulations in force in the country of use are undertaken.

## 10.2 Electrically heated units only.

For the service engineer, please note that there is a thermal cut-out incorporated in the air curtain which needs to be manually reset. The cut-out is located near to the mains terminal block.

Re-setting the thermal cut-out may help to identify the nature of the fault however we do not recommend re-set without a thorough investigation into why the cut-out operated.



fig.10. Thermal cut-out

## 10.3 Electronic Controller.

If the air curtain goes into thermal trip (overheat) the AC-ACR-PANEL keypad displays an 'ERR' code. Refer to air curtain instructions to remedy.

The electronic control base unit is protected from any short circuit on the air sensor or heatsink sensor as the short circuit will cause the temperature to go high and trigger over temperature alarm.



fig.11 Electronic controller

**1: Polarity:** Use a multimeter to check correct polarity between all three cores i.e. that +12V goes to +12V, DATA goes to DATA, and GND to GND.

**2: Continuity:** Use a multimeter to check continuity between each end of all three cores.

**3: Short circuit:** Use a multimeter to check that there are no short circuits between any of the three cores.

**N.B.** This test should be done with both ends of the cable disconnected to avoid false readings.

**4: Plugs:**

**a)** Check that the correct length of insulation has been stripped from each core.

**b)** Check the tightness of the cables in the plugs.

## 10.4 SmartElec Controllers.

The SmartElec control raises an alarm if any of its inputs are outside their normal working scope. The alarms are displayed on the program panel as an "alarm" code with a prefix "a". See chart over.

As the alarms are not mutually exclusive, the alarm code displayed on the program panel are accumulative. For example, if both air sensor and heatsink sensor fail, the Program panel will display "a 20" as the Alarm code.

Apart from the communication failure alarm [code a1], which could be due to a broken connection of the RS485 link, all other alarms will cause the Base unit to switch off the heater output.

The SmartElec base unit is protected from any short circuit on the air sensor or heatsink sensor as the short circuit will cause the temperature to go high and trigger over temperature alarm.

There are five basic checks to perform should 'a1' appear on the program panel display. These are as follows:

**1: Polarity:** Use a multimeter to check correct polarity between all 4 cores i.e. that 0v goes to 0v, 7v goes to 7v, A to A, and B to B.

**2: Continuity:** Use a multimeter to check continuity between each end of all four cores.

**3: Short circuit:** Use a multimeter to check that there are no short circuits between any of the four cores.

**N.B.** This test should be done with both ends of the cable disconnected to avoid false readings.

**4: Plugs:**

**a)** Check that the correct length of insulation has been stripped from each core.

**b)** Check the tightness of the cables in the plugs.

**c)** Check that the plugs are fitted to the correct circuit board pins.

**d)** Check that the plugs are firmly seated on the circuit board pins in both the program panel and on the base unit.

**e)** Check for continuity between the plug terminal screw and the pcb pin with the plug in place, (accessible through plug moulding).

**5: Addressing:** (Network versions only). If two or more air curtains are networked, check that each base unit has a unique address as described in section 12.4.3

### 10.4.1 SmartElec fault codes

Code	Description	Symptom	Possible Cause	Remedy
a 1	<b>COMMUNICATION FAILURE.</b> Code 'a 1' is displayed when the Program panel loses communication with the base unit.	No control	- Terminals wired incorrectly	- Check wiring diagram section 5
			- Incorrect Polarity	- Swap cables to terminals '0V' & '7V'
			- Damaged cable	- Replace with suitable wiring
a 2	<b>AIR SENSOR TOO HOT.</b> Code 'a 2' is displayed when the air sensor detects an ambient temperature above 60°C	High Ambient Air		
		Lack of air flow through & into unit.	- Impellor turning in opposite direction. - Motor failure.	- Check rotation of impellor. - Check Motor & replace if necessary.
a 4	<b>AIR SENSOR FAILURE.</b> Code 'a 4' is displayed when the air sensor is open circuit	Fan operating. No heat.	- Air sensor wiring disconnected - Air sensor Broken	- Check wires. - Replace Air Sensor.
a 8	<b>HEATSINK TOO HOT</b> Code 'a 8' is displayed when the sensor on the heatsink detects a temperature above 65°C		- High Ambient air/damaged Heatsink	- Replace SmartElec Base unit.
			- Damaged Cooling Fan	- Replace cooling fan
a 16	<b>HEATSINK SENSOR FAILURE.</b> Code 'a 16' is displayed when the heatsink is open circuit		- Heatsink wiring disconnected	- Check wires.
			- Heatsink Broken	- Replace SmartElec Base unit.

### 10.4.2 SmartElec base unit LED indicator location/function:

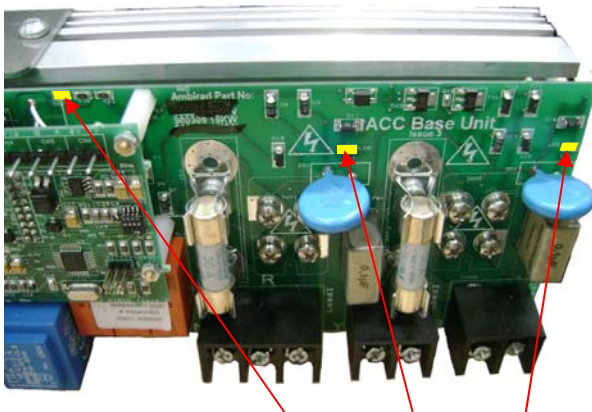

No heat fan on or off	<input type="checkbox"/>	<input checked="" type="checkbox"/>	<input checked="" type="checkbox"/>
Heat on fan on	<input checked="" type="checkbox"/>	<input type="checkbox"/>	<input type="checkbox"/>
Up to temperature	<input type="checkbox"/>	<input type="checkbox"/>	<input type="checkbox"/>

#### Key

<input type="checkbox"/>	= OFF
<input checked="" type="checkbox"/>	= ON
<input type="checkbox"/>	= PULSING

# 11. Parts replacement.

## 11.1 Rotor and motor replacement.

**Warning**  
Ensure electrical power is isolated from the product.

Follow steps 1 - 4 below.

### Step 1

Remove 3 screws securing fan bearing plate to access panel.

Carefully remove plate with bearing housing from rotor bearing.



### Step 2

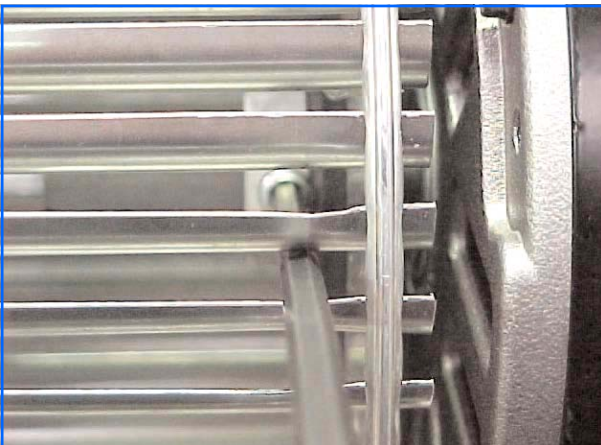

Slacken the grub screw securing rotors to the motor shaft, remove rotor.

Repeat steps 1 - 2 for opposite rotor.



### Step 4

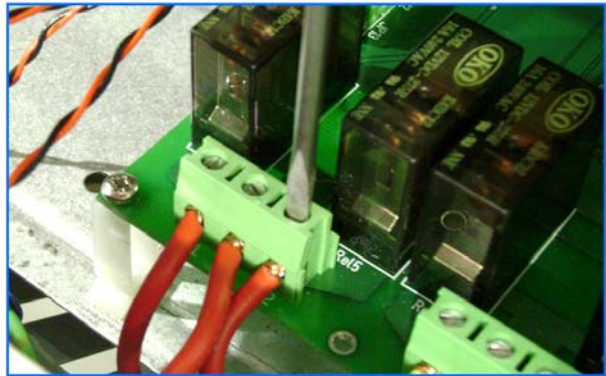

Disconnect the wires from the motor to the mains terminal rail.

### Step 5

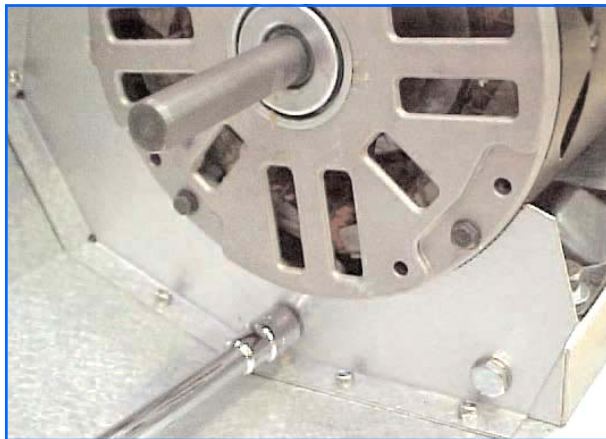

Remove the bolts securing the motor to the chassis.

Replace motor as required.

### Step 6

Refit in reverse of previous steps and test the performance of the product.

## 11.2 Element replacement.

For access follow steps 1 to 4 above.

### Step 1.

Carefully remove connections to element, noting wiring configuration.

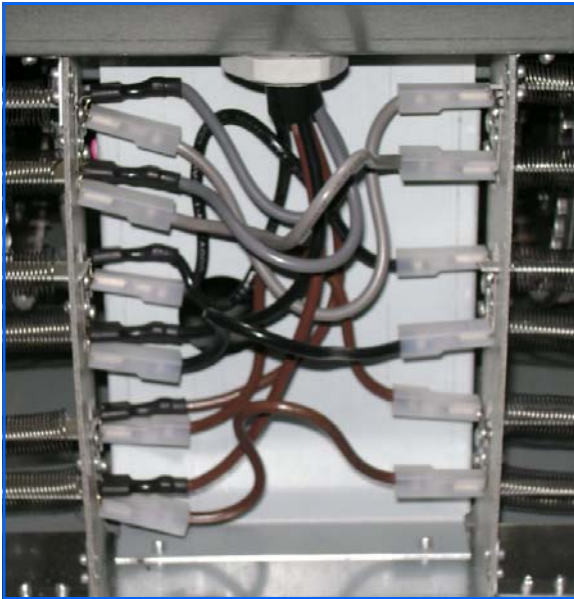

### Step 3.

Lift out element cartridge, replace as required.

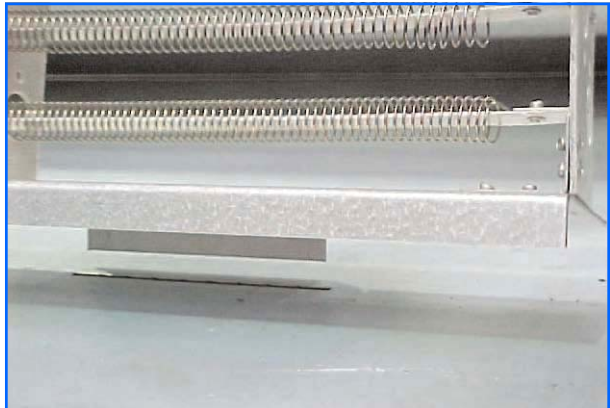

Refit in reverse order (including (motor refit on previous page)

Test performance of the product.

### Step 2.

Remove two bolts securing elements.



## 12. User Instructions.

fig.12. AC-ACR-PANEL Programmer



### 12.1 Keypad

The **SELECT** button will allow you to navigate.

The **+** button will allow you to increase the setting.

The **-** button will allow you to decrease the setting.



### 12.2 Operation

On first power up, the display panel will have the following default settings:

- F. 0 (no fan)
- H. 0 (no heat)
- 1. 16 (°C. Heat set point - Auto mode only)
- 2. 7 (°C. half heat set point - Auto mode only)
- D. 2 (fan speed in door switch mode)

**Note:** Subsequent power ups will retain any entered settings in the display panel internal memory.

Press the **+** or **-** buttons to toggle between the 'F' (Fan), 'H' (Heat) and On/Off Parameters.

Prefix 'F' denotes the **FAN SPEED**. This can be either 1: slow ; 2: medium or 3: fast speed. 0 setting denotes the unit is **OFF**.

To alter the current speed, press the **SELECT** button. The value will start flashing.

Press the **+** or **-** buttons to increase/decrease the desired setting.

Press the **SELECT** button to confirm new setting. A delay of 7 seconds will return to the original display.

Prefix 'H' denotes the **HEAT** setting. This can be either 1: low heat; or 2: high heat. 0 setting denotes the unit is set at fan only.

To alter the current setting, press the **SELECT** button. The value will start flashing.

Press the **+** or **-** buttons to increase/decrease the desired setting.

Press the **SELECT** button to confirm new setting. A delay of 7 seconds will return to the original display.



The next parameter will either turn the unit On or Off.

To turn the unit Off, press the  button. 'On' will start flashing.

Press the  button. 'Off' will start flashing.

Press the  button to confirm new setting.

To turn the unit On, press the  button. 'Off' will start flashing.

Press the  button to alter to 'On'.

Press the  button to confirm new setting. A delay of 7 seconds will return to the 'F' Fan parameter.





## 12.3 Engineers settings



### 12.3.1 Auto Mode

The controller can be set to automatic control only when used in conjunction with an optional outside sensor.

To access the engineers setting, first ensure that the display is in the (H) HEAT parameter. Press and hold the  button for 5 seconds. Set point '1' will appear.



*If the outside air temperature is above this value, there is no heat power. If the outside temperature falls below this value but is above set point 2, then the heat will be at half power. (Range: 0 - 30 degrees).*

To alter the setting, press the  button then the  or  buttons to increase/decrease the desired setting.

Press the  button to confirm new value and use the  button to move to the next setting. (A delay of 7 seconds will return to the original display.)

If you have previously pressed the  button, Set point '2' will appear.

*If the outside air temperature falls below this value, the heat will be at full power. If the outside temperature is above this value but is below set point 1, then the heat will be at half power. (Range: 0 - 30 degrees)*

To alter the setting, press the  button then the  or  buttons to increase/decrease the desired setting.



Press the  button to confirm new value.





Press the  button, setting "A.Of" will appear.

*This setting will enable the Auto Mode. (Range: On/Off)*

To alter the setting, press the  button then the

 or  buttons to toggle between the "A.Of" and "A.On" modes. "A.On" enables the air curtain to run under automatic control from the optional outdoor sensor. "A.Of" enables the air curtain to run under normal control.

*To return to the engineering setting mode press and hold the  button for 5 seconds.*



*To return to normal operating mode press and hold the  button for 5 seconds.*

### 12.3.2 Door Switch Mode

The controller can be set to a preset fan speed when the door opens. This function can only be used in conjunction with a door switch.

To access the engineers setting, first ensure that the display is in the (F) FAN parameter. Press and hold the  button for 5 seconds. Setting 'd' will appear.

*The air curtain operates as normal under the program of the Fan and Heat settings. As the door opens the air curtain changes state to the settings preset in this mode. As the door closes, the air curtain returns to normal. (Range: 1: slow ; 2: medium or 3: fast speed. 0 setting denotes the unit is **OFF**.)*

To alter the setting, press the  button then the  or  buttons to increase/decrease the desired setting.

Press the  button to confirm new setting. A delay of 2 seconds will return to the original display.



## 12.4 Option SmartElec Controller

fig.13. SmartElec



### 12.4.1 Keypad

The **SELECT** button will allow you to navigate.

The **+** button will allow you to increase the setting.

The **-** button will allow you to decrease the setting.



### 12.4.2 Operation

When power is applied to the controller, the display will illuminate with the air outlet sensor temperature. This is denoted by the prefix 't' followed by the actual temperature at the probe in °C.

Pressing the **SELECT** button will advance the display to 'U 0'. This denotes a single or No. 1 air curtain.

\*Pressing the **+** button increases this number to a maximum of 15. This should be set to show the actual number of air curtains in the network. Each air curtain can be independently set by first entering the air curtain number, then pressing **SELECT** to access the parameters described below.



Pressing the **SELECT** button again will advance the display to the outlet SET temperature (default = 'S' 25)

This is denoted by the prefix 'S' followed by the required set temperature in °C. Temperature settings between 16° and 35°C can be set (16°C equals maximum savings).

Use the **+** or **-** buttons to increase/decrease the desired setting.



Pressing the **SELECT** button again will advance the display to the HEAT setting (default = 'H' 25).

This is denoted by the prefix 'H' followed by either a '0' for HEAT OFF (AMBIENT ONLY) or '1' for HEAT ON (default = 'H1')

Use the **+** or **-** buttons to increase/decrease the desired setting.



Pressing the  button again will advance the display to the FAN setting (default = 'F 1'). This is denoted by the prefix 'F' followed by either a '0' for FAN (UNIT) OFF, '1' for LOW FAN, '2' for MEDIUM FAN or '3' for HIGH FAN (default = 'F 2').

Use the  or  buttons to increase/decrease the desired setting.

Pressing the  button again will return to the first screen or will return automatically to the first screen after a period of 3 minutes.

\* 'U 0' denotes air curtain No.1, 'U 1' denotes air curtain No.2, & so on, up to a maximum of 15. See section 4 'installer wiring details' for addressing instructions.

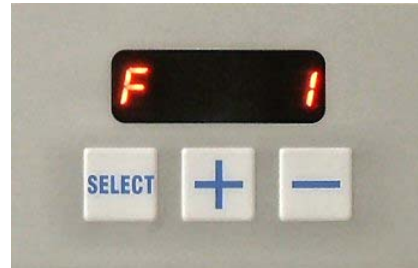

### 12.4.3 SmartElec air curtain addressing

Each air curtain in the network must have a unique address (0-15) This is achieved using the 4 way DIL switch mounted on the base unit PCB (see photo).

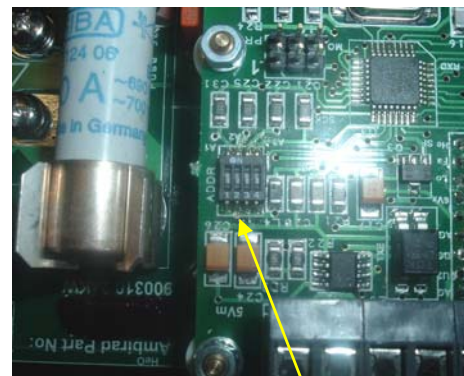
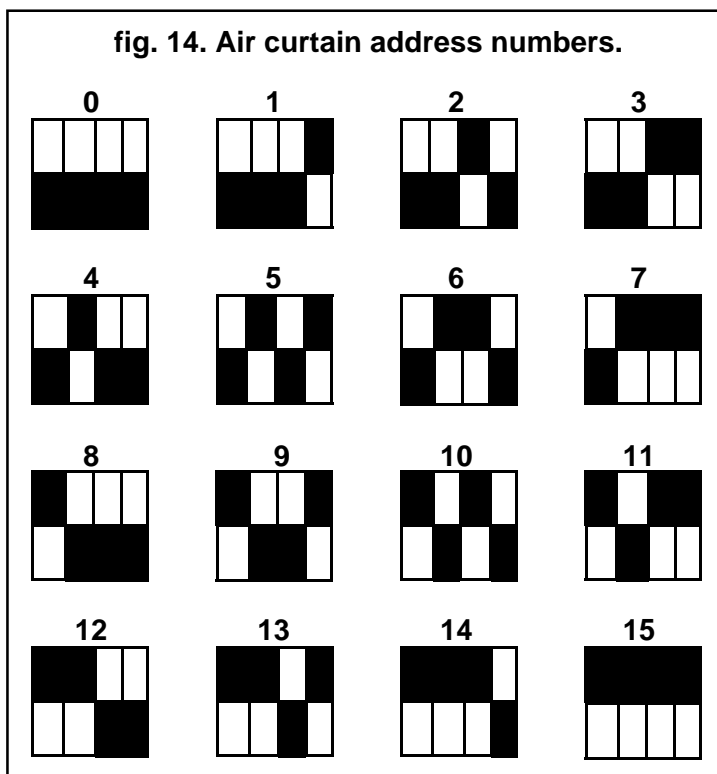

**DIL SWITCH**

The black shaded areas represent the switch position.

The example opposite shows the air curtain set to No.1.

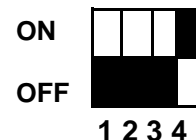

An AmbiRad Group brand



AmbiRad Limited Fens Pool Avenue  
Brierley Hill West Midlands DY5 1QA  
United Kingdom.



Telephone 01384 489700  
Facsimile 01384 489707  
Email marketing@airbloc.co.uk  
Website www.airbloc.co.uk  
Technical Support www.s-i-d.co.uk



Airbloc is a registered trademark of AmbiRad Limited. Because of continuous product innovation, AmbiRad reserve the right to change product specification without due notice.